

# GoldStar

website:<http://www.lgeservice.com>  
e-mail:<http://www.lgeservice.com/techsup.html>

# MICROWAVE OVEN

## OWNER'S MANUAL & COOKING GUIDE

PLEASE READ THIS OWNER'S MANUAL  
THOROUGHLY BEFORE OPERATING.

**MA6511W**  
**MA6511B**

## ***Thank you for purchasing a Goldstar microwave oven***

Please record the model number and serial number of this unit for future reference. We also suggest you record the details of your contact with Goldstar(LG Electronics U.S.A.,Inc.) concerning this unit.

Model No: \_\_\_\_\_

Serial No: \_\_\_\_\_

Dealer: \_\_\_\_\_

\_\_\_\_\_

\_\_\_\_\_

Dealer Phone No: \_\_\_\_\_

Staple your Receipt here to prove your retail purchase.

Customer Relations  
LG Electronics U.S.A., Inc  
Service Division Bldg. #3  
201 James Record Rd.  
Huntsville, AL 35824-0126

## **PRECAUTIONS TO AVOID POSSIBLE EXPOSURE TO EXCESSIVE MICROWAVE ENERGY**

- (a) Do not attempt to operate this oven with the door open since open-door operation can result in harmful exposure to microwave energy. It is important not to defeat or tamper with the safety interlocks.
- (b) Do not place any object between the oven front face and the door or allow soil or cleaner residue to accumulate on sealing surfaces.
- (c) Do not operate the oven if it is damaged. It is particularly important that the oven door close properly and that there is no damage to the:
  - (1) Door (bent),
  - (2) Hinges and latches (broken or loosened),
  - (3) Door seals and sealing surfaces.
- (d) The oven should not be adjusted or repaired by anyone except properly qualified service personnel.

# CONTENTS

<b>TECHNICAL SPECIFICATIONS</b> .....	3
<b>IMPORTANT SAFETY INSTRUCTIONS</b> .....	4
<b>INSTALLATION</b> .....	5
<b>OTHER HELPFUL INFORMATION</b> .....	6
<b>PRECAUTIONS</b> .....	6
<b>GETTING THE BEST RESULTS FROM YOUR MICROWAVE OVEN</b> .....	6
<b>SPECIAL TECHNIQUES IN MICROWAVE COOKING</b> .....	7
<b>HOW FOOD CHARACTERISTICS AFFECT MICROWAVE COOKING</b> .....	7
<b>COOKING UTENSILS</b> .....	8
<b>FEATURE DIAGRAM</b> .....	9
<b>OPERATION CHECK</b> .....	9
<b>OPERATING INSTRUCTIONS</b> .....	9
<b>HEATING OR REHEATING GUIDE</b> .....	10
<b>COOKING GUIDE</b> .....	11
<b>CLEANING</b> .....	12
<b>BEFORE CALLING FOR SERVICE</b> .....	12
<b>WARRANTY</b> .....	Inside back cover

## TECHNICAL SPECIFICATIONS

MODEL	MA6511W/MA6511B
Power Supply	120 V AC, 60 Hz
Rated Power Consumption	900 W
Microwave Output	*600 W
Frequency	2450 MHz
Rated Current	8.0 A
Overall Dimensions(WXHxD)	17 <sup>21</sup> / <sub>23</sub> " X 11 <sup>2</sup> / <sub>11</sub> " X 12 <sup>3</sup> / <sub>5</sub> "
Oven Cavity Dimensions(WXHxD)	12 <sup>3</sup> / <sub>16</sub> " X 7 <sup>31</sup> / <sub>32</sub> " X 11 <sup>5</sup> / <sub>18</sub> "
Effective Capacity of Oven Cavity	0.6 Cu.ft.

\*IEC 60705 RATING STANDARD  
 Specifications subject to change without prior notice.

# IMPORTANT SAFETY INSTRUCTIONS

**WARNING** - To reduce the risk of burns, electric shock, fire, injury to persons, or exposure to excessive microwave energy:

1. Read all instructions before using the appliance.
2. Read and follow the specific **PRECAUTIONS TO AVOID POSSIBLE EXPOSURE TO EXCESSIVE MICROWAVE ENERGY** found on page 2 of this manual.
3. This appliance must be grounded. Connect only to properly grounded outlet. See **GROUNDING INSTRUCTIONS** found on page 5 of this manual .
4. Install or locate this appliance only in accordance with the provided installation instructions.
5. Some products, such as whole eggs and sealed containers – for example, closed glass jars – may explode and should not be heated in this oven.
6. Use this appliance only for its intended use as described in the manual. Do not use corrosive chemicals or vapors in this appliance. This type of oven is specifically designed to heat, cook, or dry food. It is not designed for industrial or laboratory use.
7. As with any appliance, close supervision is necessary when used by children.
8. Do not operate this appliance if it has a damaged cord or plug, if it is not working properly, or if it has been damaged or dropped.
9. This appliance should be serviced only by qualified service personnel. Contact the nearest authorized service facility for examination, repair, or adjustment.
10. Do not cover or block any openings on the appliance.
11. Do not store this appliance outdoors. Do not use this product near water - for example, near a kitchen sink, in a wet basement, or near a swimming pool, and the like.
12. Do not immerse cord or plug in water.
13. Keep cord away from heated surfaces.
14. Do not let cord hang over the edge of a table or counter.
15. When cleaning surfaces of door and oven that comes together on closing the door, use only mild, nonabrasive soaps or detergents applied with a sponge or soft cloth.
16. To reduce the risk of fire in the oven cavity:
  - a. Do not overcook food. Carefully attend appliance if paper, plastic, or other combustible materials are placed inside the oven to facilitate cooking.
  - b. Remove wire twist-ties from paper or plastic bags before placing bag in oven.
  - c. If materials inside the oven should ignite, **KEEP OVEN DOOR CLOSED**, turn oven off, and disconnect the power cord or shut off power at the fuse or circuit breaker panel.
  - d. Do not use the cavity for storage purposes. Do not leave paper products, cooking utensils, or food in the cavity when not in use.
17. Do not heat any type of baby bottles or baby food. Uneven heating may occur and could cause personal injury.
18. Avoid heating small-necked containers such as syrup bottles.
19. Avoid using corrosive and vapors, such as sulfide and chloride.
20. Liquids heated in certain shaped containers (especially cylindrical-shaped containers) may become overheated. The liquid may splash out with a loud noise during or after heating or when adding ingredients (instant coffee, etc.), resulting in harm to the oven and possible injury. In all containers, for best results, stir the liquid several times before heating. Always stir liquid several times between reheatings.

**SAVE THESE INSTRUCTIONS**

# INSTALLATION

## A. GROUNDING INSTRUCTIONS

This appliance must be grounded. In the event of an electrical short circuit, grounding reduces the risk of electric shock by providing an escape wire for the electric current. This appliance is equipped with a cord having a grounding wire with a grounding plug. The plug must be plugged into an outlet that is properly installed and grounded.

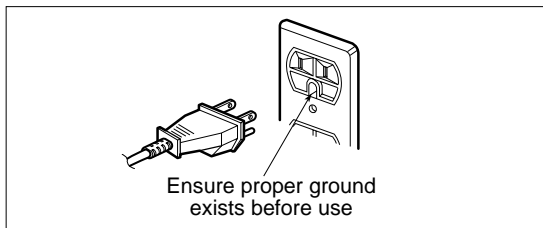

## WARNING

Improper grounding can result in a risk of electric shock. Consult a qualified electrician if the grounding instructions are not completely understood, or if doubt exists as to whether the appliance is properly grounded, and either:

1. If it is necessary to use an extension cord, use only a 3-wire extension cord that has a 3-blade grounding plug, and a 3-slot receptacle that will accept the plug on the appliance. The marked rating of the extension cord shall be equal to or greater than the electrical rating of the appliance, or
2. Do not use an extension cord. If the power supply cord is too short, have a qualified electrician or serviceman install an outlet near the appliance.

### NOTE:

1. A short power-supply cord is provided to reduce the risks resulting from becoming entangled in or tripping over a longer cord.
2. Longer cord sets or extension cords are available and may be used if care is exercised in their use.
3. If a long cord or extension cord is used, (1) the marked electrical rating of the cord set or extension cord should be at least as great as the electrical rating of the appliance, (2) the extension cord must be a grounding-type 3-wire cord, and (3) the longer cord should be arranged so that it will not drape over the countertop or tabletop where it can be pulled on by children or tripped over accidentally.

## B. CIRCUITS

For safety purposes this oven must be plugged into a 15 Amp circuit. No other electrical appliances or lighting circuits should be on this line. If in doubt, consult a licensed electrician.

## C. VOLTAGE WARNING

The voltage used at the wall receptacle must be the same as specified on the oven name plate located on the back or on the side of the control panel of the oven. Use of a higher voltage is dangerous and may result in a fire or other type of accident causing oven damage. Low voltage will cause slow cooking. In case your microwave oven does not perform normally in spite of proper voltage, remove and reinsert the plug.

## D. PLACEMENT OF THE OVEN

Your microwave oven can be placed easily in your kitchen, family room, or anywhere else in your home. Place the oven on a flat surface such as a kitchen countertop or a specially designed microwave oven cart. Do not place oven above a gas or electric range. Free air flow around the oven is important.

## E. DO NOT BLOCK AIR VENTS

All air vents should be kept clear during cooking. If air vents are covered during oven operation the oven may overheat. In this case, a sensitive thermal safety device automatically turns the oven off. The oven will be inoperable until it has cooled sufficiently.

## F. RADIO INTERFERENCE

1. Microwave oven operation may interfere with TV or radio reception.
2. When there is interference, it may be reduced or eliminated by taking the following measures:
  - a. Clean the door and the sealing surfaces of the oven.
  - b. Reorient the receiving antenna of radio or television.
  - c. Relocate the microwave oven in relation to the TV or radio.
  - d. Move the microwave oven away from the receiver.
  - e. Plug the microwave oven into a different outlet so that microwave oven and receiver are on different branch circuits.

## OTHER HELPFUL INFORMATION

### PRECAUTIONS

- \*Be certain to place the front surface of the door three inches away or more from the countertop edge to avoid accidental tipping of the appliance in normal usage.
- \*For the most accurate programming of the electronic units, touch the center of each pad securely. Do not touch several pads at one time or touch between pads. A beep sound should be heard with each touch when a pad is touched correctly.
- \*Do not hit or strike the control with objects such as silverware, utensils, etc. Breakage may occur.
- \*Be careful when taking the cooking utensils out of the oven. Some dishes absorb heat from the cooked food and may be hot.
- \*Do not rinse cooking utensils by immediately placing them into water just after cooking. This may cause breakage. Allow the turntable to cool.
- \*Use only specific glass utensils. See cooking utensils section in this manual.
- \*Do not operate the oven empty. Either food or water should always be in the oven during operation to absorb microwave energy.
- \*Do not use your microwave oven to dry newspapers or clothes. They can catch fire.
- \*Use only thermometers approved for microwave oven cooking.
- \*Be certain the turntable is in place when you operate the oven.
- \*Pierce the skin of potatoes, whole squash, apples, or any fruit or vegetable which has a skin covering before cooking.
- \*Never use your microwave oven to cook eggs in the shell. Pressure can build up inside the shell causing it to burst.
- \*Do not pop popcorn, except in a microwave-safe container or commercial package designed especially for microwave ovens. Never try to pop popcorn in a paper bag not designed for microwave oven use. Overcooking may result in smoke and fire. Do not repop unpopped kernels. Do not reuse popcorn bags.

### GETTING THE BEST RESULTS FROM YOUR MICROWAVE OVEN

**Keep an eye on things.** The instructions in this book have been formulated with great care, but your success in preparing them depends, of course, on how much attention you pay to the food as it cooks. Always watch your food while it cooks. Your microwave oven is equipped with a light that turns on automatically when the oven is in operation so that you can see inside and check the progress of your recipe. Directions given in recipes to elevate, stir, and the like should be thought of as the minimum steps recommended. If the food seems to be cooking unevenly, simply make the necessary adjustments you think appropriate to correct the problem.

**Factors affecting cooking times.** Many factors affect cooking times. The temperature of ingredients used in a recipe makes a big difference in cooking times. For example, a cake made with ice-cold butter, milk, and eggs will take considerably longer to bake than one made with ingredients that are at room temperature. All of the recipes in this book give a range of cooking times. In general, you will find that the food remains under-cooked at the lower end of the time range, and you may sometimes want to cook your food beyond the maximum time given, according to personal preference. The governing philosophy of this book is that it is best for a recipe to be conservative in giving cooking times. While undercooked food may always be cooked a bit more, overcooked food is ruined for good. Some of the recipes, particularly those for bread, cakes, and custard, recommend that food be removed from the oven when they are slightly undercooked. This is not a mistake. When allowed to stand, usually covered, these foods will continue to cook outside of the oven as the heat trapped within the outer portions of the foods gradually travels inward. If the foods are left in the oven until they are cooked all the way through, the outer portions will become overcooked or even burnt. As you gain experience in using your microwave oven, you will become increasingly skillful in estimating both cooking and standing times for various foods.

## OTHER HELPFUL INFORMATION

### SPECIAL TECHNIQUES IN MICROWAVE COOKING

**Browning:** Meats and poultry that are cooked fifteen minutes or longer will brown lightly in their own fat. Foods that are cooked for a shorter period of time may be brushed with a browning sauce to achieve an appetizing color. The most commonly used browning sauces are Worcestershire sauce, soy sauce, and barbecue sauce. Since relatively small amounts of browning sauces are added to foods, the original flavor of recipes are not altered.

**Covering:** A cover traps heat and steam and causes food to cook more quickly. You may either use a lid or microwave cling-film with a corner folded back to prevent splitting.

**Covering with waxed paper:** Waxed paper effectively prevents spattering and helps food retain some heat. Since it makes a looser cover than a lid or cling-film, it allows the food to dry out slightly.

**Wrapping in waxed paper or paper towel:** Sandwiches and many other foods containing prebaked bread should be wrapped prior to microwaving to prevent drying out.

**Arranging and spacing:** Individual foods such as baked potatoes, small cakes, and hors d'oeuvres will heat more evenly if placed in the oven and equal distance apart, preferably in a circular pattern. Never stack foods on top of one another.

**Stirring:** Stirring is one of the most important of all microwaving techniques. In conventional cooking, foods are stirred for the purpose of blending. Microwaved foods, however, are stirred in order to spread and redistribute heat. Always stir from the outside towards the center as the outside food heats first.

**Turning over:** Large, tall foods such as roasts and whole chickens should be turned so that the top and bottom will cook evenly. It is also a good idea to turn cut-up chicken and chops.

**Placing thicker portions near the edge:** Since microwaves are attracted to the outside portion of foods, it makes sense to place thicker portions of meat, poultry and fish to the outer edge of the baking dish. This way, thicker portions will receive the most microwave energy and the foods will cook evenly.

**Elevating:** Thick or dense foods are often elevated so that microwaves can be absorbed by the underside and center of the foods.

**Piercing:** Foods enclosed in a shell, skin, or membrane are likely to burst in the oven unless they are pierced prior to cooking. Such foods include both yolks and whites of eggs, clams and oysters, and many whole vegetables and fruits.

**Testing if cooked:** Because foods cook so quickly in a microwave oven, it is necessary to test food frequently. Some foods are left in the microwave until completely cooked, but most foods, including meats and poultry, are removed from the oven while still slightly undercooked and allowed to finish cooking during standing time. The internal temperature of foods will rise between 5°F (3°C) and 15°F (8°C) during standing time.

**Standing time:** Foods are often allowed to stand for 3 to 10 minutes after being removed from the microwave oven. Usually the foods are covered during standing time to retain heat unless they are supposed to be dry in texture (some cakes and biscuits, for example). Standing allows foods to finish cooking and also helps flavors to blend and develop.

### HOW FOOD CHARACTERISTICS AFFECT MICROWAVE COOKING

**Density of foods:** Light, porous food like cakes and breads cook more quickly than heavy, dense foods such as roasts and casseroles. You must take care when microwaving porous foods that the outer edges do not become dry and brittle.

**Height of foods:** The upper portion of tall foods, particularly roasts, will cook more quickly than the lower portion. Therefore, it is wise to turn tall foods during cooking, sometimes several times.

**Moisture content of foods:** Since the heat generated from microwaves tends to evaporate moisture, relatively dry foods such as roasts and some vegetables should either be sprinkled with water prior to cooking or covered to retain moisture.

**Bone and fat content of foods:** Bones conduct heat and fat cooks more quickly than meat. Therefore, care must be taken when cooking bony or fatty cuts of meat that the meats do not cook unevenly and do not become overcooked.

## OTHER HELPFUL INFORMATION

**Shape of foods:** Microwaves penetrate only about 1 inch (2.5cm) into foods; the interior portion of thick foods is cooked as the heat generated on the outside travels inward. In other words, only the outer edge of any foods is actually cooked by microwave energy; the rest is cooked by convection. It follows then that the worst possible shape for a food that is to be microwaved is a thick cube. The corners will burn long before the center is even warm. Round thin and ring shaped foods cook most successfully in the microwave.

**Quantity of foods:** The number of microwaves in your oven remains constant regardless of how much food is being cooked. Therefore, the more food you place in the oven, the longer the cooking time. Remember to decrease cooking times by at least one-third when halving a recipe.

## COOKING UTENSILS

### MICROWAVE-SAFE UTENSILS

**Never use metal or metal-trimmed utensils in your microwave oven:** Microwaves cannot penetrate metal. They will bounce off any metal object in the oven and cause arcing, an alarming phenomenon that resembles lightning. Most heat-resistant non-metallic cooking utensils are safe for use in your microwave oven. However, some may contain materials that render them unsuitable as microwave cookware. If you have any doubts about a particular utensil, there's a simple way to find out if it can be used in your microwave oven.

**Testing utensils for microwave use:** Place the utensil in question next to a glass bowl filled with water in the microwave oven. Microwave at power HIGH for 1 minute. If the water heats up but the utensil remains cool to the touch, the utensil is microwave-safe. However, if the water does not change temperature but the utensil becomes warm, microwaves are being absorbed by the utensil and it is not safe for use in the microwave oven. You probably have many items on hand in your kitchen that can be used as cooking equipment in your microwave oven. Just read through the following checklist.

**1. Dinner plates:** Many kinds of dinner-ware are microwave-safe. If in doubt consult the manufacturer's literature or perform the microwave test, above.

**2. Glassware:** Glassware that is heat-resistant is microwave-safe. This includes all brands of oven-tempered glass cookware. However, do not use delicate glassware, such as tumbler or wine glasses, as these might shatter as the food warms.

**3. Paper: Paper plates and containers are convenient and safe to use in your microwave oven, provided the cooking time is short and foods to be cooked are low in fat and moisture.** Paper towels are also very useful for wrapping foods and for lining baking trays in which greasy foods, such as bacon, are cooked. In general, avoid colored paper products as the color may run.

**4. Plastic storage containers:** These can be used to hold foods that are to be quickly reheated. However, they should not be used to hold foods that will need considerable time in the oven as hot foods will eventually warp or melt plastic containers.

**5. Plastic cooking bags:** These are microwave-safe provided they are specially made for cooking. However, **be sure to make a slit in the bag** so that steam can escape. Never use ordinary plastic bags for cooking in your microwave oven, as they will melt and rupture.

**6. Plastic microwave cookware:** A variety of shapes and sizes of microwave cookware is available. For the most part, you can probably cook with items you already have on hand rather than investing in new kitchen equipment.

**7. Pottery, stoneware, and ceramic:** Containers made of these materials are usually fine for use in your microwave oven, but they should be tested to be sure.

**CAUTION: SOME ITEMS ARE NOT INTENDED FOR COOKING, INCLUDING SOME STONEWARE AND ITEMS WITH HIGH IRON OR LEAD CONTENTS.**



# FEATURE DIAGRAM

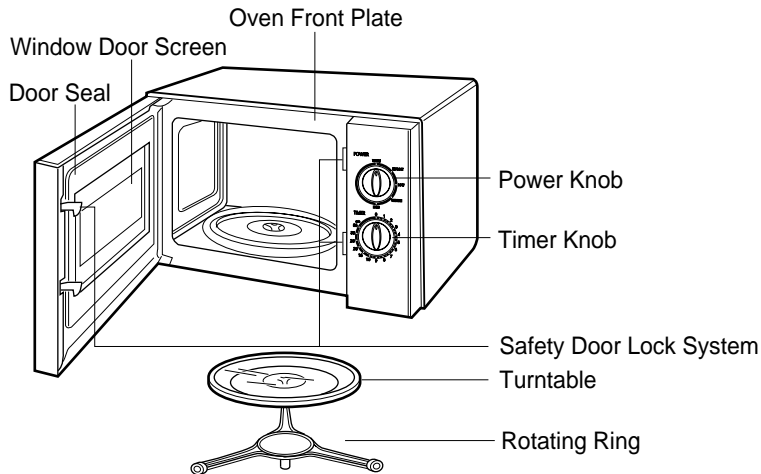

Your oven will be packed with the following materials:

- Glass Turntable ..... 1 each
- Owner's Manual & Cooking Guide ..... 1 each
- Rotating Ring ..... 1 each

This microwave oven is designed for household use only. It is not recommended for commercial purposes.

# OPERATION CHECK

After unpacking this appliance, examine the new oven for evidence of shipping damage. This is most important since a damaged oven may allow the escape of microwave energy. Make sure you remove all packing from the microwave cavity. Check the oven operation when unpacking the unit and any time the oven is not working properly.

1. Plug the power cord into an earthed electrical socket.
2. Place the glass tray inside the oven cavity.
3. Place a cup of water (at room temperature) inside the oven, on the glass tray.
4. Close the door securely.
5. Turn the POWER SELECT KNOB to cook.
6. Set the TIMER for 3 to 4 minutes (note : microwave activity starts).
7. When the cooking time has elapsed, the signal will sound (note: all microwave activity stops).
8. If the oven is operating normally, the water will be hot.

# OPERATING INSTRUCTIONS

The microwave oven is designed to be simple and easy to operate. Please follow these instructions carefully.

1. Place the food in a suitable cooking utensil. Open the microwave oven door and place the utensil in the center of the oven on the glass tray.
2. Close the oven door.
3. Select the cooking power level by turning the **POWER SELECT KNOB**  
For your information, the defrost power level utilizes 33% of the oven's total available power while the cook power level utilizes 100% of the oven's total available power.
4. Turn the **TIMER KNOB** clockwise to set the cooking time.

**When popping a popcorn;**  
Place carefully bag does not touch oven walls. Fold each end of the bag in half toward the center top of the bag.

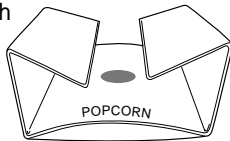

## NOTE :

The oven starts as soon as the **KNOB** is turned. We recommend turning the **KNOB** past the time you want and then turn back to the desired setting.

1. When the **TIMER** reaches zero(0), the signal sounds and the oven will automatically shut off.
2. Open the door and remove the food from the oven.
3. To stop cooking before the **TIMER** reaches zero(0), either open the door or simply turn the **TIMER** to zero(0).

## NOTE :

The door can be opened during the cooking process by pushing the **Door Open Button**. The **TIMER** will stop and the microwave activity will cease. When the door is closed, cooking will resume until the full cooking time has elapsed. After cooking is finished, the **TIMER** will be at zero(0).

## MICROWAVE POWER LEVELS

Your microwave oven is equipped with five power levels (5 steps) to give you flexibility and control over cooking. The table below will give you some idea of which foods are prepared at each of the various power levels.

**MICROWAVE POWER LEVEL CHART**

Power Level	Output(of watts)	Use
<b>High</b>	<b>100%</b>	<ul style="list-style-type: none"> <li>• Boil water.</li> <li>• Brown ground beef.</li> <li>• Cook fresh fruits &amp; vegetables.</li> <li>• Mak candy.</li> <li>• Cook fish, meat &amp; poultry.</li> <li>• Preheat browning dish.</li> </ul>
<b>Medium</b>	<b>77%</b>	<ul style="list-style-type: none"> <li>• All reheating.</li> </ul>
<b>Low</b>	<b>55%</b>	<ul style="list-style-type: none"> <li>• Bake cakes, muffins.</li> <li>• Prepare eggs.</li> <li>• Cook meat, poultry.</li> <li>• Cook custard</li> <li>• Prepare rice, soup.</li> </ul>
<b>Defrost</b>	<b>33%</b>	<ul style="list-style-type: none"> <li>• All defrosting</li> </ul>
<b>Warm</b>	<b>17%</b>	<ul style="list-style-type: none"> <li>• Soften butter &amp; cheese.</li> </ul>

## HEATING OR REHEATING GUIDE

To heat or reheat successfully in the microwave, it is important to follow several guidelines. Measure the amount of food in order to determine the time needed to reheat. Arrange the food in a circular pattern for best results. Room temperature food will heat faster than refrigerated food. Canned foods should be taken out of the can and placed in a microwavable container. The food will be heated more evenly if covered with a microwavable lid or plastic wrap, vented. Remove cover carefully to prevent steam burns. Use the following chart as a guide for reheating cooked food.

Items	Cook time (at HIGH)	Special Instructions
Sliced meat 3 slices(1/4-inch thick)	1 1/2~2 minutes	Place sliced meat on microwavable plate. Cover with plastic wrap and vent.  *Note: Gravy or sauce helps to keep meat juicy.
Chicken piece 1 breast 1 leg and thigh	2~3 minutes 1 1/2~2 minutes	Place chicken pieces on microwavable plate. Cover with plastic wrap and vent.
Fish fillet (6~8 oz.)	1 1/2~2 minutes	Place fish on microwavable plate. Cover with plastic wrap and vent.
Lasagna 1 serving(10 1/2 oz.)	5~7 minutes	Place lasagna on microwavable plate. Cover with plastic wrap and vent.
Casserole 1 cup 4 cups	1 1/2~3 minutes 5~7 minutes	COOK covered in microwavable casserole. Stir once halfway through cooking.
Casserole cream or cheese 1 cup 4 cups	1 1/2~2 1/2 minutes 4~6 minutes	COOK covered in microwavable casserole. Stir once halfway through cooking.
Sloppy Joe or Barbecued beef 1 sandwich (1/2 cup meat filling) without bun	1 ~2 1/2 minutes	Reheat filling and bun separately. Cook filling covered in microwavable casserole. Stir once. Heat bun as directed in chart below.
Mashed potatoes 1 cup 4 cups	2~3 minutes 6~8 minutes	COOK covered in microwavable casserole. Stir once halfway through cooking.
Baked beans 1 cup	2~3 minutes	COOK covered in microwavable casserole. Stir once halfway through cooking.
Ravioli or pasta in sauce 1 cup 4 cups	3~4 minutes 8~11 minutes	COOK covered in microwavable casserole. Stir once halfway through cooking.
Rice 1 cup 4 cups	1 1/2~2 minutes 4~6 minutes	COOK covered in microwavable casserole. Stir once halfway through cooking.
Sandwich roll or bun 1 roll	20~35 seconds	Wrap in paper towel and place on glass microwavable rack.
Vegetables 1 cup 4 cups	2 1/2~3 1/3 minutes 4~6 minutes	COOK covered in microwavable casserole. Stir once halfway through cooking.
Soup 1 serving(8 oz.)	2~3 minutes	COOK covered in microwavable casserole. Stir once halfway through cooking.

# COOKING GUIDE

Food	Container	Cover	Time, min. (at HIGH)	Special instructions
Ground beef(1 lb.) Crumbled (for casseroles or soup)	Casserole	Yes	7-10	Stir every 2 minutes. Add sauce or casserole ingredients and finish. To cook frozen block, microwave 9 to 12 minutes, breaking up and stirring every 4 minutes.
Meatballs(1 lb.)	Pie plate	wax paper	6-10	Arrange $\frac{3}{4}$ to 1-inch apart in circle around edge of dish. Rotate dish $\frac{1}{4}$ turn after half of time.
Bacon 4 slices(1 oz. each)	Microwave safe plate or paper towel	paper towel	4-5	Arrange in single layer on paper towels or on trivet set in dish.
Sausage (2 patties)	Microwave safe utensil		1-5	Arrange in single layer. Rotate dish $\frac{1}{4}$ turn after half of time.
Fish fillets or steak(1 lb.)	square dish	wax paper or plastic wrap	6-7	Microwave until fish flakes easily. Let stand 3 minutes before serving.
Chicken pieces (2 $\frac{1}{2}$ to 3 lb.)	square dish	wax paper	20-25	Brush with browning agent if desired. Arrange in single layer in cooking dish so thickest, meaty pieces are to outside edges of dish.
Scrambled eggs	glass measuring cup or casserole	No	1-2 per egg	Place 1 teaspoon butter per egg in dish. Microwave until melted. Scrambled eggs with the butter and 1 tablespoon milk per egg. Place in oven and microwave for half of total time. Scrape portions from the outside to the center. Finish cooking. Allow to stand 1 to 2 minutes to set eggs.
Rice, regular long grain(1 cup)	1 $\frac{1}{2}$ qt. casserole	lid or plastic wrap	15-20	Add 1 $\frac{1}{2}$ cups hot tap water and 1 teaspoon salt, stir after 7 minutes. Let stand covered 5 minutes before serving.
Rice, minute(1 cup)	1 $\frac{1}{2}$ qt. casserole	lid or plastic wrap	13-18	Add 1 $\frac{1}{2}$ cups hot taps water, stir after 6 minutes. Let stand covered 5 minutes before serving.
Corn on the cob, fresh (1 ear)	casserole	wrap	5-8	Add 2 to 4 tablespoons of water. Rotate dish $\frac{1}{4}$ turn after half of time.
Carrot(1 lb.)	casserole	wrap	7-9	Cut carrots into slices $\frac{1}{2}$ inch thick. Add $\frac{1}{4}$ cup water.
Broccoli fresh(1 lb.)	casserole	wrap	7-9	Add $\frac{1}{4}$ cup water.
Onions fresh( $\frac{1}{2}$ lb.)	casserole	wrap	4-7	Use small, whole onions. Add $\frac{1}{4}$ cup water.
Peas Green fresh(1 lb.) frozen 10 oz.	casserole casserole	wrap wrap	6-10 7-10	Add $\frac{1}{3}$ cup water.
Potatoes 2 EA. (6 oz. each)	casserole	wrap	9-10	Rinse and pat dry. Prick with fork several times. Arrange in circular pattern on paper lined oven bottom, equal distance apart. Turn over after half of time. Let stand 5 minutes before serving.
Sauces Melted butter sauces, clarified butter (1 $\frac{1}{2}$ cups)	glass measure	No	1-2	Microwave butter just to melt. For clarified butter, bring to boil then let stand until layers separate. Pour off and use clear top layer.

# CLEANING

Before cleaning the oven, unplug the power supply cord of the oven. If impossible, open the oven door to prevent an accidental oven start.

## INSIDE OF THE OVEN

Use a damp cloth to wipe out crumbs and spillovers. It is important to keep the area between door and cavity front clean to assure a tight seal. Remove greasy spatters with a sudsy cloth, then rinse and dry.  
Do not use harsh detergent or abrasive cleaners.

## GLASS TRAY

The glass tray can be washed by hand or in dishwasher.

## CONTROL PANEL

Wipe with a damp cloth followed immediately by a dry cloth.

## DOOR

If steam accumulates inside or around the outside of the oven door, wipe the panel with a soft cloth. This may occur when the microwave oven is operated under high humidity conditions and in no way indicates a malfunction of the unit.

## OUTSIDE OVEN SURFACE

Clean with damp cloth. To prevent damage to the operating parts inside the oven, the water should not be allowed to seep into the ventilation openings.

After cleaning the oven, be sure that the rotating ring and the glass tray are in the right position. And turn the TIMER to zero(0).

# BEFORE CALLING FOR SERVICE

Please check your problem by using the guide below and try the solutions for each problem. If the microwave oven still does not work properly, contact the nearest authorized service center.

## OVEN WILL NOT START AT ALL

- \* Electrical cord for oven is not plugged in.
  - Plug into the outlet.
- \* Door is open.
  - Close the door open and try again.
- \* Wrong operation is set.
  - Check operation instructions.

## ARCING OR SPARKING

- \* Materials to be avoided in microwave oven are used.
  - Use microwave-safe cookware only.
- \* The oven is operated when empty.
  - Do not operate with oven empty.
- \* Food refuse remains in the cavity or inside the cavity is uncleaned.
  - Clean cavity with wet towel.

## UNEVEN COOKING OR POOR DEFROSTING

- \* Materials to be avoided in microwave oven are used.
  - Use microwave-safe cookware only.
- \* Cooking time/Cooking power level is not suitable.
  - Use correct time/Cooking power level.
- \* Food is not turned or stirred.
  - Turn or stir food.

## OVERCOOKED FOODS

- \* Cooking time/Cooking power level is not suitable.
  - Use correct time/cooking power level.

## UNDERCOOKED FOODS

- \* Materials to be avoided in microwave oven are used.
  - Use microwave-safe cookware only.
- \* Food is not defrosted completely.
  - Completely defrost food.
- \* Oven ventilation ports are restricted.
  - Check to see that oven ventilation ports are not restricted.
- \* Cooking time/Cooking power level is not suitable.
  - Use correct time/Cooking power level.

## ALL THESE THINGS ARE NORMAL

- \* Dull thumping sound during oven operation.
- \* Steam or vapor escaping from around the door.
- \* Light reflection around door or outer wrapper.
- \* Dimming oven light and change in blower sound during oven operation at power levels other than high.
- \* Some radio and TV interference might occur during operations. It is similar to the interference caused by other small appliances such as mixers, blow dryer, etc.

**LIMITED WARRANTY (USA)  
GOLDSTAR MICROWAVE OVEN**

LG Electronics will repair or at its option replace, without charge, your product which proves to be defective in material or workmanship under normal use, during the warranty period listed below from the date of original purchase. **This warranty is good only to the original purchaser of the product during the warranty period as long as it is in the United States, including Alaska, Hawaii, and US Territories.**

**WARRANTY PERIOD**

**MODEL #**  
MA6511W  
MA6511B

**LABOR**  
Year

**PARTS**  
1 Year

**MAGNETRON**  
8 Years

**HOW SERVICE IS HANDLED**

Call 1-800-243-0000 and choose the appropriate prompt. (24 hours a day, 7 days per week) Please have product type (Microwave) and ZIP Code ready.  
Model MA6511W receives carry-in service.  
Model MA6511B receives carry-in service.

No other express warranty is applicable to this product. **THE DURATION OF ANY IMPLIED WARRANTIES, INCLUDING THE IMPLIED WARRANTY OF MERCHANTABILITY, IS LIMITED TO THE DURATION OF THE EXPRESS WARRANTY HEREIN. LG ELECTRONICS USA, INC. SHALL NOT BE LIABLE FOR THE LOSS OF THE USE OF THE PRODUCT, INCONVENIENCE, LOSS OR ANY OTHER DAMAGES, DIRECT OR CONSEQUENTIAL, ARISING OUT OF THE USE OF, OR INABILITY TO USE, THIS PRODUCT OR FOR ANY BREACH OF ANY EXPRESS OR IMPLIED WARRANTY, INCLUDING THE IMPLIED WARRANTY OF MERCHANTABILITY APPLICABLE TO THIS PRODUCT.**

Some states do not allow the exclusion or limitation of incidental or consequential damages or limitations on how long an implied warranty lasts, so these limitations or exclusions may not apply to you. This warranty gives you specific legal rights and you may also have other rights which vary from state to state.

**THE ABOVE WARRANTY DOES NOT APPLY TO:**

1. Service trips to your home to deliver and pickup, install, instruct, or replace house fuses or correct wiring or correction of unauthorized repairs.
2. Damages to the hood due to fire, to the microwave, or from fire, lightning, or other causes.

MA6511W 18.7548 0 0 8.7648 208.553 9.7539005 110 Pro alW



P/NO.: 3828W5A2425

Printed in China