



WASHING MACHINE SERVICE MANUAL

⚠ CAUTION

READ THIS MANUAL CAREFULLY TO DIAGNOSE
PROBLEMS CORRECTLY BEFORE SERVICING THE UNIT.

**MODEL : GCW1069QS
GCW1069CS**



MARCH. 2010 PRINTED IN KOREA

P/No. : MFL30599165

CONTENTS

1.IMPORTANT SAFETY INSTRUCTIONS	3
2. SPECIFICATIONS	4
3. FEATURES AND TECHNICAL EXPLANATION	5
4. PARTS IDENTIFICATION	7
5. INSTALLATION INSTRUCTIONS	8
6. OPERATION	14~16
7. WIRING DIAGRAM/PROGRAM CHART	17
8. TROUBLESHOOTING	18~20
8-1. BEFORE PERFORMING SERVICE	18
8-2. QC TEST MODE	18
8-3. HOW TO CHECK THE WATER LEVEL FREQUENCY	18
8-4. HOW TO CHECK THE RPM	18
8-5. ERROR DISPLAY	19~20
8-6. DISPENSER	21
9. DIAGNOSIS AND TROUBLESHOOTING	22~29
10. DISASSEMBLY INSTRUCTIONS	30~38
11. EXPLODED VIEW	39
11-1-1. CABINET & CONTROL PANEL ASSEMBLY - COIN TYPE	39
11-1-2. CABINET & CONTROL PANEL ASSEMBLY - CARD TYPE	40
11-2. DRUM & TUB ASSEMBLY	41
11-3. DISPENSER ASSEMBLY	42

1. IMPORTANT SAFETY INSTRUCTIONS

READ ALL INSTRUCTIONS BEFORE USE

⚠ WARNING

For your safety, the information in this manual must be followed to minimize the risk of fire or explosion, electric shock, or to prevent property damage, personal injury, or loss of life.

IMPORTANT SAFETY INSTRUCTIONS

⚠ WARNING: To reduce the risk of fire, electric shock, or injury to persons when using the washer, follow basic precautions, including the following:

- Read all instructions before using the washer.
- Do not wash articles that have been previously cleaned in, washed in, soaked in, or spotted with gasoline, dry cleaning solvents, or other flammable or explosive substances, as they give off vapors that could ignite or explode.
- Do not add gasoline, dry cleaning solvents, or other flammable or explosive substances to the wash water. These substances give off vapors that could ignite or explode.
- Under certain conditions, hydrogen gas may be produced in a hot water system that has not been used for 2 weeks or more. **HYDROGEN GAS IS EXPLOSIVE.** If the hot water system has not been used for such a period, before using the washing machine, turn on all hot water faucets and let the water flow from each for several minutes. This will release any accumulated hydrogen gas. As the gas is flammable, do not smoke or use an open flame during this time.
- Do not allow children to play on or in the washer. Close supervision of children is necessary when the washer is used near children.
- Before the washer is removed from service or discarded, remove the door to prevent children from hiding inside.
- Do not install or store the washer where it will be exposed to the weather.
- Do not tamper with controls.
- Do not repair or replace any part of the washer or attempt any servicing unless specifically recommended in the user-maintenance instructions or published user-repair instructions that you understand and have the skills to carry out.
- See Installation Instructions for grounding requirements.
- **ALWAYS** follow the fabric care instructions supplied by the garment manufacturer.
- Do not place items exposed to cooking oil in your washer. Items contaminated with cooking oils may contribute to a chemical reaction that could cause a load to catch fire.
- Do not use fabric softeners or products to eliminate static unless recommended by the manufacturer of the fabric softener or product.

SAVE THESE INSTRUCTIONS

GROUNDING INSTRUCTIONS

This appliance must be grounded. In the event of malfunction or breakdown, grounding will reduce the risk of electric shock by providing a path of least resistance for electric current. This appliance is equipped with a cord having an equipment-grounding conductor and grounding plug. The plug must be plugged into an appropriate outlet that is properly installed and grounded in accordance with all local codes and ordinances.

- Do not use an adapter or extension cord.
- Do not remove ground prong.
- If you don't have the proper outlet, consult an electrician.

⚠ WARNING: Improper connection of the equipment-grounding conductor can result in risk of electric shock.

Check with a qualified electrician or serviceman if you are in doubt as to whether the appliance is properly grounded. Do not modify the plug provided with the appliance - if it does not fit the outlet, have a proper outlet installed by a qualified electrician.

2. SPECIFICATIONS

MODEL		GCW1069QD / GCW1069QS / GCW1069CD / GCW1069CS
COLOR		BLUE WHITE
POWER SUPPLY		120V~, 60 Hz
PRODUCT WEIGHT		190 lbs. (86 kg)
ELECTRIC POWER CONSUMPTION	WASHING	155 W
	DRAIN MOTOR	80 W
REVOLUTION SPEED	WASH	45 rpm
	SPIN	1150RPM
CYCLES		4
OPTIONS		ADD SUPER WASH Cycle
OPERATIONAL WATER PRESSURE		14.5-116 psi (100-800 kPa)
CONTROL TYPE		Electronic
WASH CAPACITY [cu. ft.]		4.2(IEC 3.64)
DIMENSIONS		27"(W) X 30 ³ / ₁₆ "(D) X 38 ¹¹ / ₁₆ "(H) X 50 ¹³ / ₁₆ "(D, door open)
DOOR SWITCH TYPE		PTC + Solenoid
WATER LEVEL		10 steps (by sensor)
LAUNDRY LOAD SENSING		Incorporated
ERROR DIAGNOSIS		Incorporated

3. FEATURES & TECHNICAL EXPLANATION

3-1. FEATURES



■ **Direct Drive System**

The advanced Brushless DC motor directly drives the drum without belt and pulley.

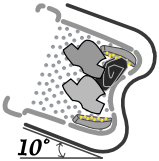

■ **The Tilted Drum and Extra Large Door Opening**

Tilted drum and extra large door opening make it possible to load and unload easily.



■ **Ultra Capacity**

The larger drum enables not just higher head drop and stronger centrifugal force, but also less tangling and wrinkling of the laundry. Heavier loads, such as king size comforters, blankets, and curtains, can be washed.

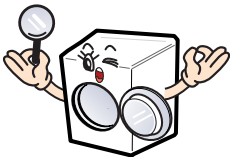

■ **Large Door and Window**

The large window lets you see the wash as it progresses.



■ **The Stainless Steel drum**

Stainless Steel Drum doesn't rust.

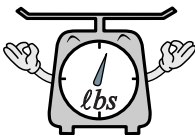

■ **Automatic Wash Load Detection**

Automatically detects the load and optimizes the washing time.

3-2. WATER LEVEL CONTROL

- This model incorporates a pressure sensor which can sense the water level in the tub.
- The water supply is stopped when the water level reaches the preset level; then the selected cycle begins.
- Spinning does not proceed until the water in the tub drains to a certain level.

3-3. DOOR CONTROL

- The door can be opened by pulling the door handle whenever washer is not in operation.
- When the cycle is completed, the DOOR LOCKED light will turn off.
- If a power failure has occurred while in operation, the door will unlock after 2 minutes.
- Clicking sounds can be heard when the door is locked/unlocked.

3-4. THE DOOR CAN NOT BE OPENED

- While program is operating.
- While Door Lock lights turn on.
- While the drum is rotating.

3-5. DOOR LOCKED LAMP LIGHTS

- When the frequency of water level is lower than 22.9 kHz.
(It can be canceled when the frequency is more than 23.8 kHz.)
- When the temperature inside the tub is higher than 45° C (104° F) and water level is not 25.5 kHz.
(It can be canceled when the water level is 25.5 kHz or the temperature inside the tub is lower than 40° C (113° F).)

4. PARTS IDENTIFICATION

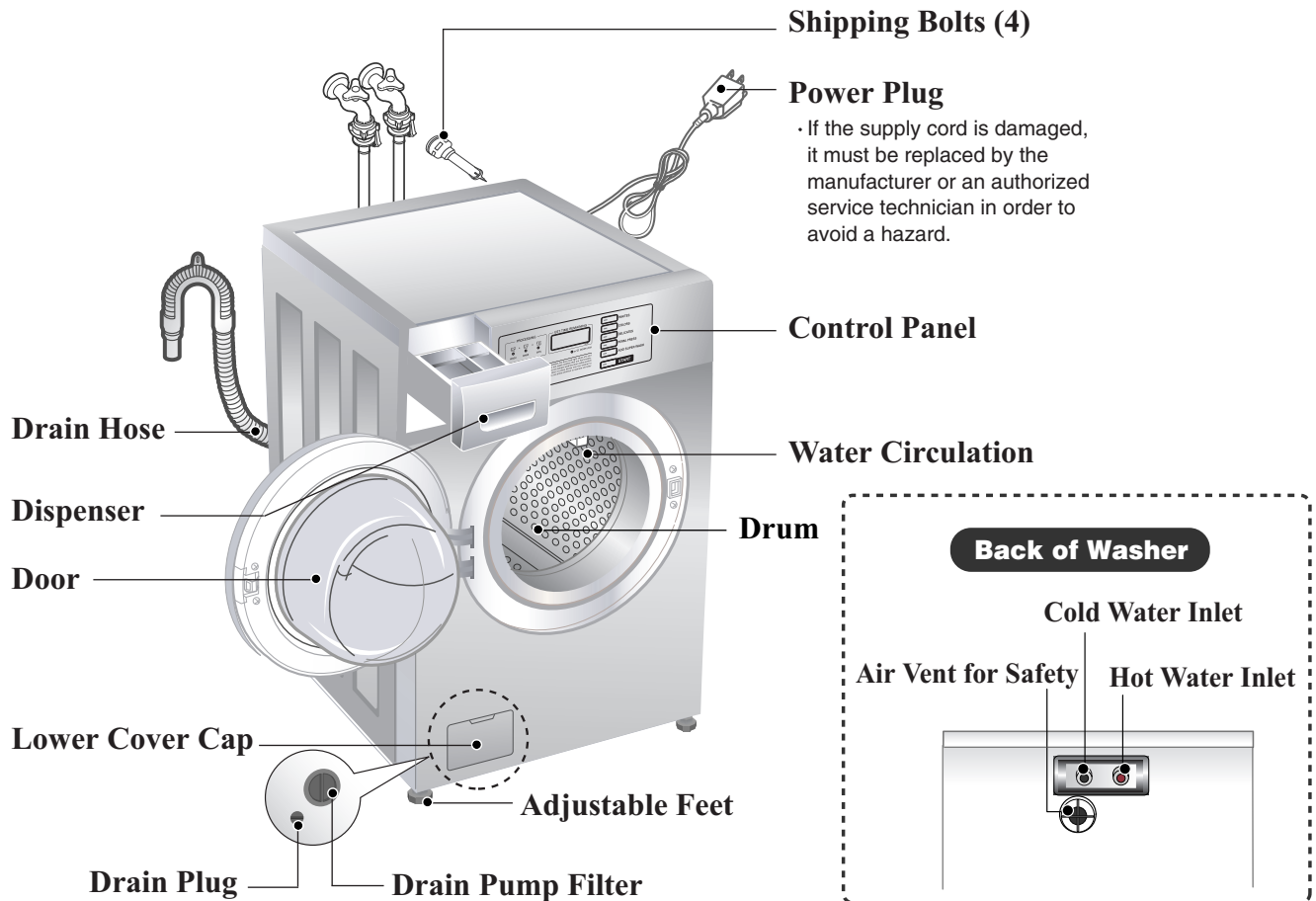

- Name: Front-loading Washing Machine
- Power supply: 120V~ 60Hz
- Size: 686 mm (W) X 767 mm (D) X 982 mm (H), 129.1 cm (D with door open)
27"(W) X 29³/₄"(D) X 38¹¹/₁₆"(H), 50¹³/₁₆"(D with door open)
- Weight: 190 lbs. (86 kg)
- Wash capacity: 3.63 cu.ft (IEC:4.2 cu.ft)
- Spin speed: 1150 rpm max.
- Permissible water pressure: 14.5~116 psi (100~800 kPa)

Note

Specifications subject to change by manufacturer.

Accessories

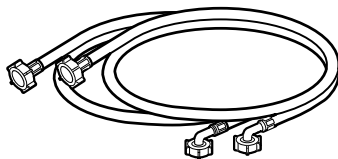

**Hot/Cold (1each)
Hose**

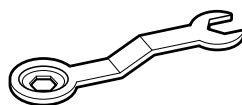

Wrench

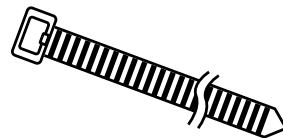

Tie strap
to secure drain hose to standpipe
inlet hose, or laundry tub

5. INSTALLATION INSTRUCTIONS

⚠ WARNING

- **Washer is heavy.** Two or more people may be needed to install and move the appliance. Failure to do so can result in back or other injury.
- **Store and install the washer where it will not be exposed to temperatures below freezing or exposed to outdoor weather conditions.** Failure to follow this warning can cause serious injury, fire, electrical shock, or death.
- **This appliance must be properly grounded for personal safety.** Properly ground washer to conform with all governing codes and ordinances. Failure to follow this warning can cause serious injury, fire, electrical shock, or death.
- **Do not install the washer in humid spaces to reduce the risk of electric shock.** Failure to follow this warning can cause serious injury, fire, electrical shock or death.
- The base opening must not be obstructed by carpeting when the washer is installed on a carpeted floor.
- **Do not remove ground prong.** Do not use an adapter or extension cord. Plug into a grounded 3 prong outlet. Failure to follow this warning can cause serious injury, fire, electrical shock or death.
- **Keep the area underneath and around your appliances free of combustible materials such as lint, paper, rags, chemicals, etc.** Failure to do so can result in fire.
- To reduce the risk of personal injury, adhere to all industry recommended safety procedures including the use of long sleeved gloves and safety glasses. Failure to follow all of the safety warnings in this manual could result in property damage, personal injury or death.

■ Shipping bolts

The appliance is fitted with shipping bolts to prevent internal damage during transportation. Packing and all shipping bolts must be removed before using the washer.

- ☞ When unpacking the base, be sure to remove the additional packing support in the middle of the base packing.

■ Removing shipping bolts

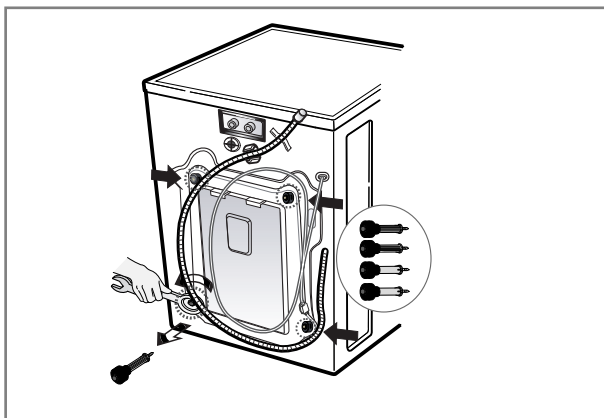

Unscrew the 4 bolts with the wrench supplied
Take out the 4 bolts by twisting the braces slightly

- ※ Keep the 4 bolts and the wrench for future use
(Whenever the appliance is transported, the shipping bolts and braces must be replaced.)

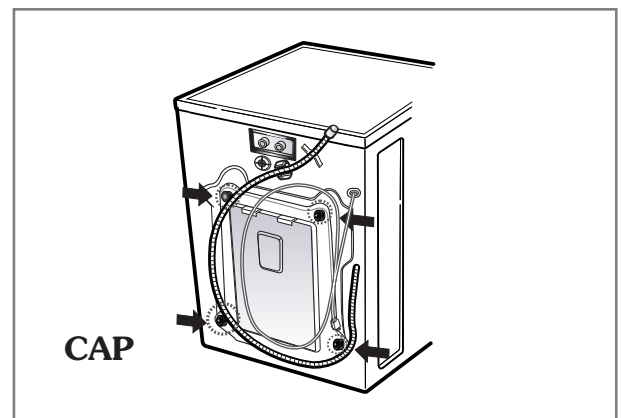
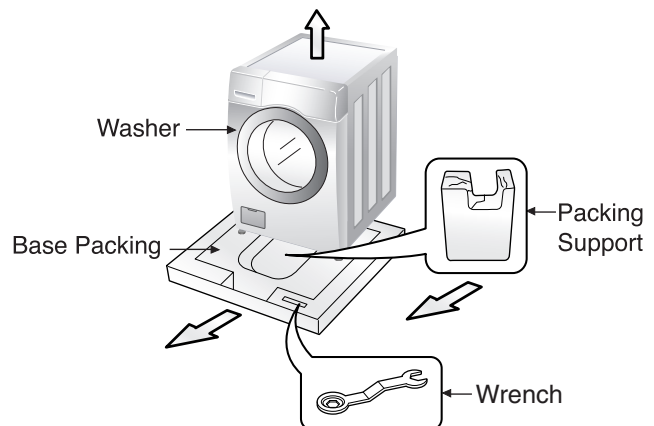

Close the holes with the caps supplied.

■ **Installation clearances**

The location must be large enough to open the washer door completely.

■ **Washer dimensions**

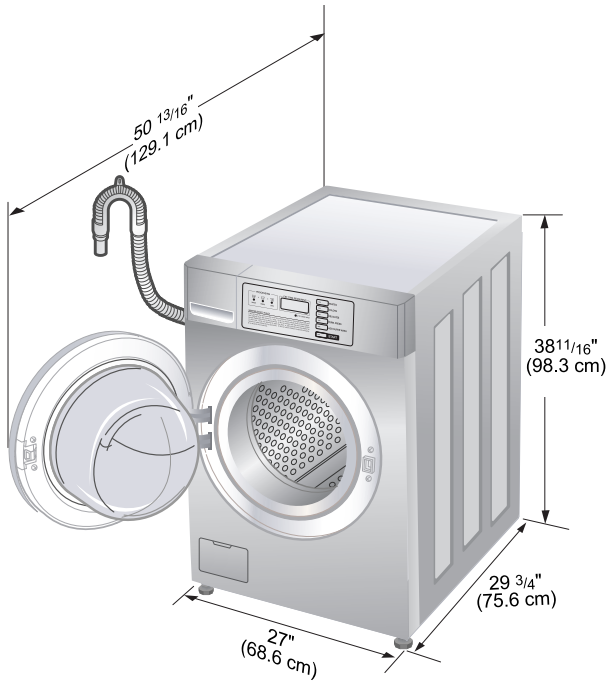

■ **Minimum installation spacing for recessed area installation.**

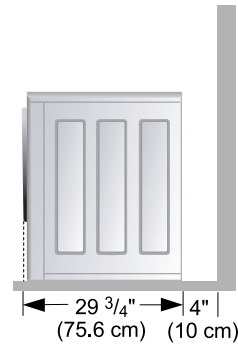

Side view

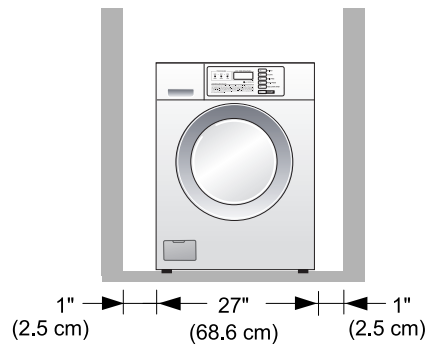

Front view

The following dimensions shown are for the minimum spacing allowed.

Additional spacing should be considered for installation and servicing.

- Additional clearances might be required for wall, door, and floor moldings.
- Additional spacing of $4"$ (10 cm) on back, $1"$ (2.5 cm) on all sides of the washer is recommended to reduce noise transfer.

Companion appliance spacing should also be considered.

■ **INSTALL THE APPLIANCE
ON A FLAT AND FIRM SURFACE**

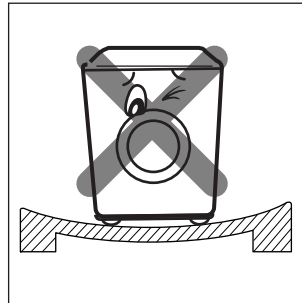
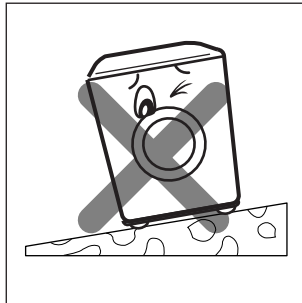
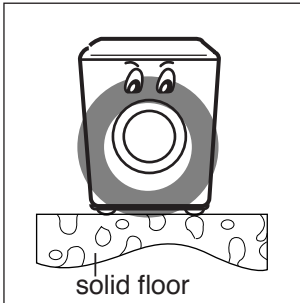

■ **Level floor**

- Allowable slope under entire washer is 1°.
- **To minimize noise and vibration, the washer MUST be installed on a solidly constructed floor.**
- Carpeting and soft tile surfaces are not recommended.
- Never install the washer on a platform or weakly supported structure.

NOTE: A firm, solid floor is even more critical to a front-loading washer than to a top-loader. If your floor is wood and/or frame construction, you may need to reinforce it. Front-loaders use substantially faster spin speeds than top-loaders, causing greater vibration. If the floor is not solid, your washer will vibrate. You will hear and feel the vibration throughout your house.

■ **CONNECT POWER PLUG**

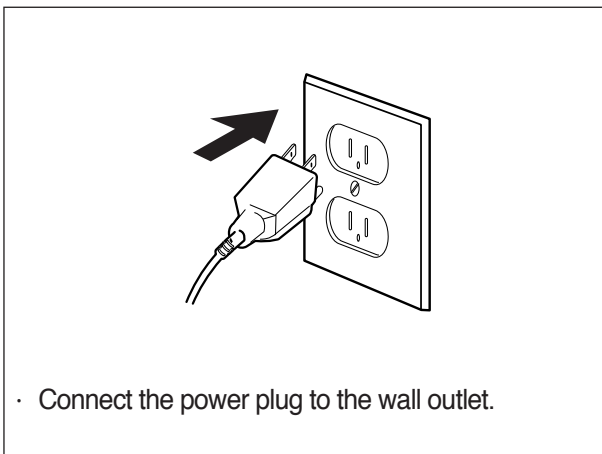

- Must be within 60" (1.5 m) of either side of the washer. Do not overload the outlet with more than one appliance.
- Time-delay fuse or circuit breaker is recommended.

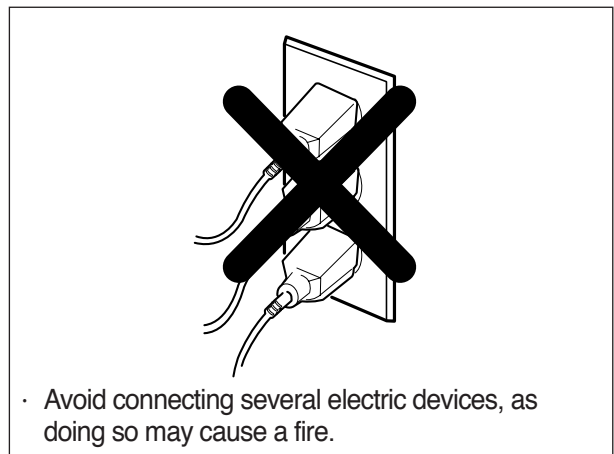

NOTE: It is the personal responsibility and obligation of the customer to have a proper outlet installed by a qualified electrician.

■ Level adjustment

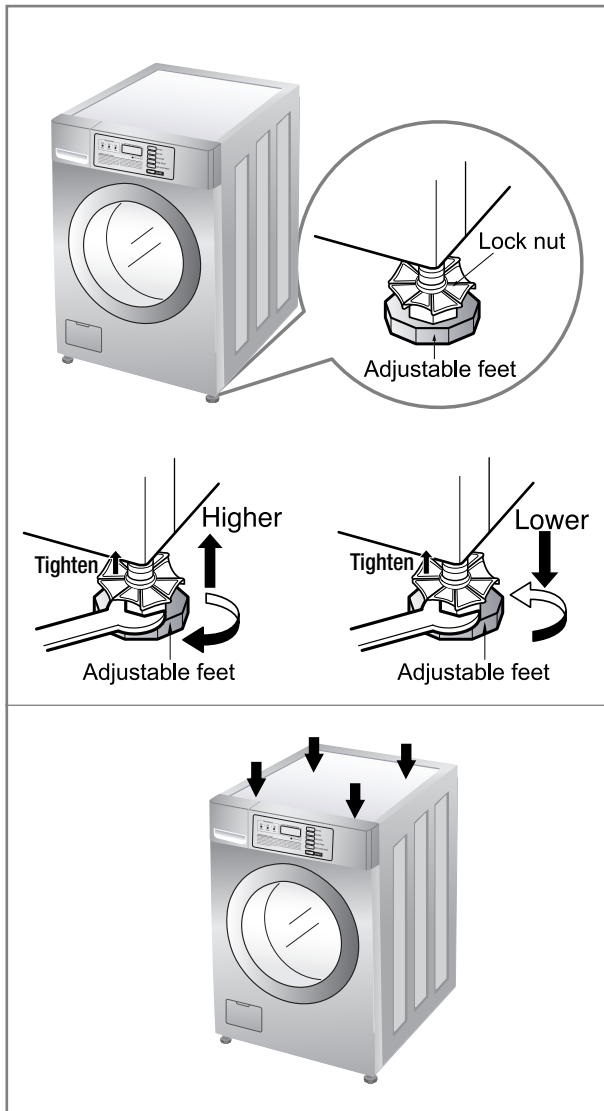

- Leveling the washing machine properly prevents excessive noise and vibration. Install the appliance on a solid and level floor surface, preferably in a corner of the room.
- If the floor is uneven, adjust the adjustable feet as required. (Do not insert pieces of wood, etc. under the feet.)

NOTE: Extend the feet no more than necessary to level the washer. The more the feet are extended, the more the washer will vibrate.

- Make sure that all four feet are stable and resting on the floor and then check that the appliance is perfectly level (Use a level).
- After the washer is level, tighten the lock nuts up against of the base of the washer. All lock nuts must be tightened.
- It is critical to adjust the feet perfectly. This must be done while the washer is spinning with a load. Use the wrench (supplied) to adjust the feet until there is no vibration. Then tighten the lock nuts to prevent further adjustment.

NOTE: If there is vibration and noise during the spin cycle, re-check the leveling of the washer, adjust the feet as required, and tighten the lock nuts securely to prevent changes in adjustment. Run the washer with a test load to make certain your washer is properly leveled. Put an unbalance weight part in the machine. You can check noise and/or vibration on high speed spin rpm through the QC test mode (refer to page 18). When the machine spins at high speed, verify that it is stable. If not, adjust the feet accordingly.

* Diagonal Check

When pushing down the edges of the washing machine top plate diagonally, the machine should not move up and down at all. (Please, check both directions.)

■ Electrical connection

- Do not use an extension cord or double adapter.
- If the supply cord is damaged, it must be replaced by a qualified person in order to avoid a hazard.
- If the machine will not be used for an extended time, unplug it, shut off the water supply and open the door to provide ventilation.
- Connect the machine to a grounded outlet in accordance with current wiring regulations.
- The appliance must be positioned so that the plug is easily accessible.

⚠ WARNING! Concerning the power cord

Most appliances recommend they be placed upon a dedicated circuit; that is, a single outlet circuit which powers only that appliance and has no additional outlets or branch circuits. Check the specification page of this owner's manual to be certain.

Do not overload wall outlets. Overloaded wall outlets, loose or damaged wall outlets, extension cords, frayed power cords, or damaged or cracked wire insulation are dangerous. Any of these conditions could result in electric shock or fire. Periodically examine the cord of your appliance, and if its appearance indicates damage or deterioration, unplug it, discontinue use of the appliance, and have the cord replaced with an exact replacement part by an authorized servicer.

Protect the power cord from physical or mechanical abuse, such as being twisted, kinked, pinched, closed in a door, or walked upon. Pay particular attention to plugs, wall outlets, and the point where the cord exits the appliance.

■ Connecting the water supply hoses

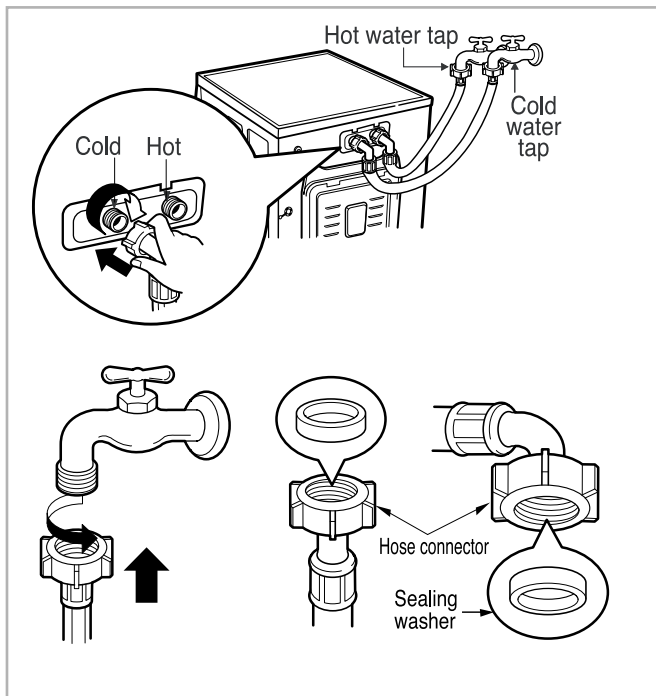

- Water supply pressure must be between 14.5 and 116 psi (100~800 kPa).
- Do not crossthread when connecting the inlet hose to the valve.
- If the water supply pressure is more than 116 PSI, a pressure reducing device should be installed.
- Two sealing washers are supplied with the water inlet hoses to prevent water leaks.
- Check for leakage of washing machine connections by turning the tap completely on.
- Periodically check the condition of the hose and replace the hose if necessary.
- Make sure that there is no kink in the hose and that it is not crushed.
- Be sure that the two water input ports are connected to the correct water faucets. The connector for hot water is colored red; the cold is blue.

NOTE: Use new hoses when installing a washing machine. Replace them periodically. Old hoses should not be used.

Do not install your washing machine in a room where temperatures below freezing may occur. Frozen hoses may burst under pressure. The reliability of the electronic control unit may be impaired at temperatures below the freezing point.

If the appliance is delivered in the winter months and temperatures are below freezing, store the washing machine at room temperature for a few hours before putting it into operation.

■ Installation of drain hose

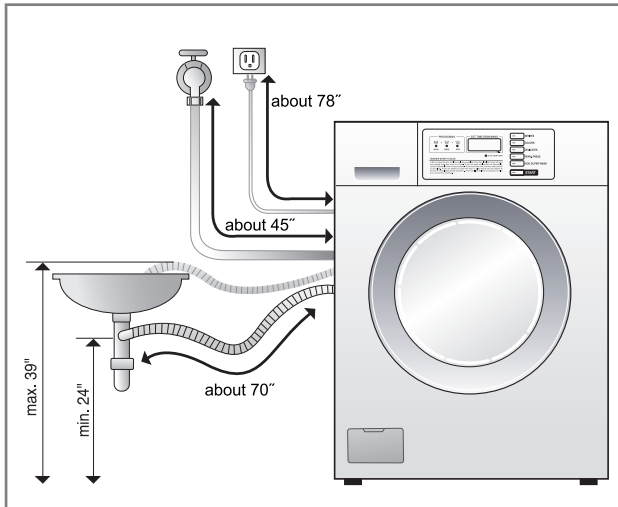

- The drain hose should not be placed higher than 96 in. from the bottom of the washer.

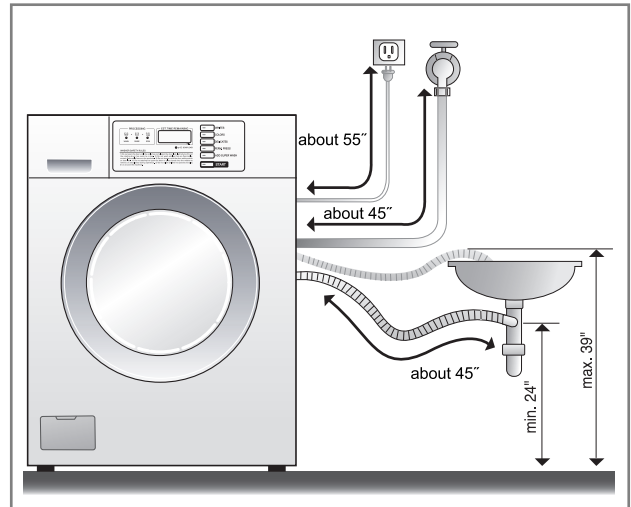

- Properly securing the drain hose will protect the floor from damage due to water leakage.

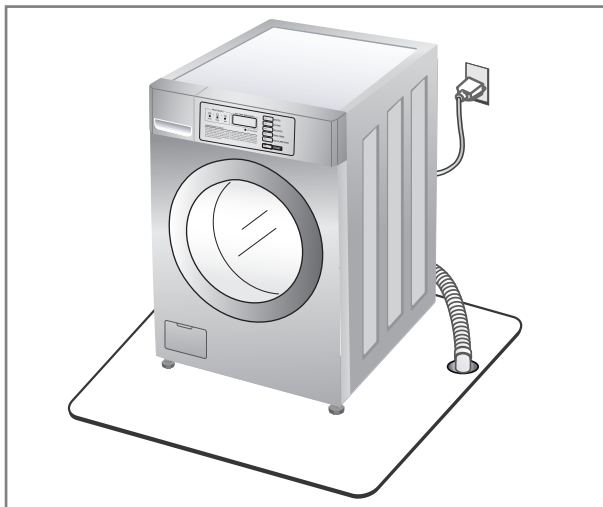

- Place the end of the drain hose in the hole of the floor drain system.

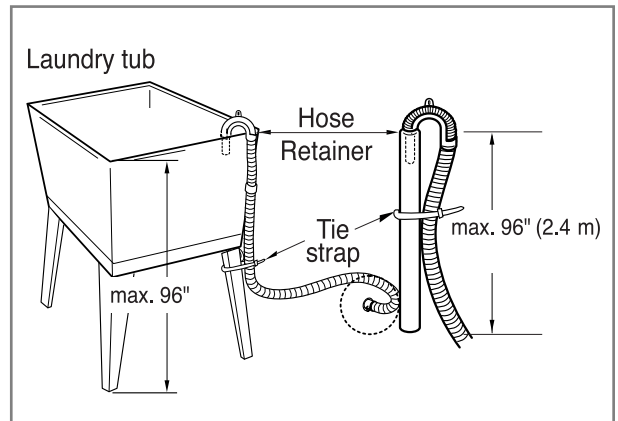

- When installing the drain hose at a sink, secure it so it cannot break away and cause flooding and damage.
- Properly securing the drain hose will protect the floor from damage due to water leakage.

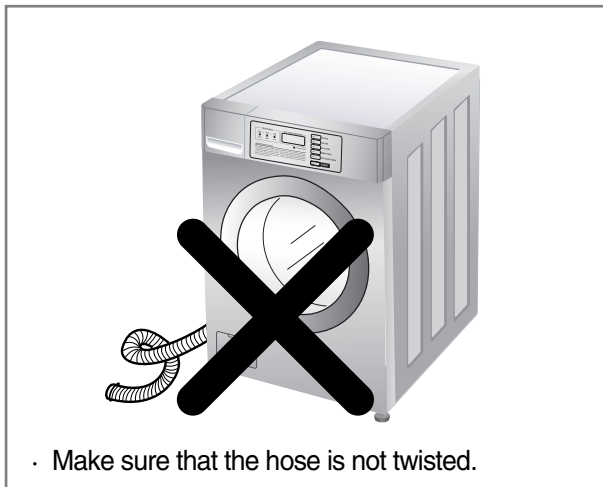

- Make sure that the hose is not twisted.

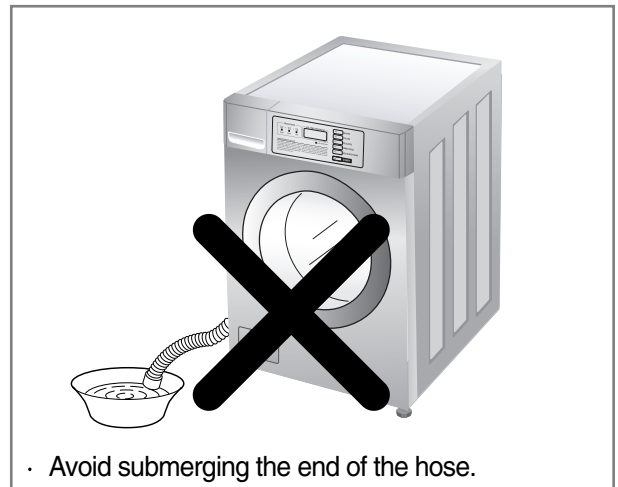

- Avoid submerging the end of the hose.

6. OPERATION

■ CARD TYPE - SIDE BY SIDE (GCW1069CS)

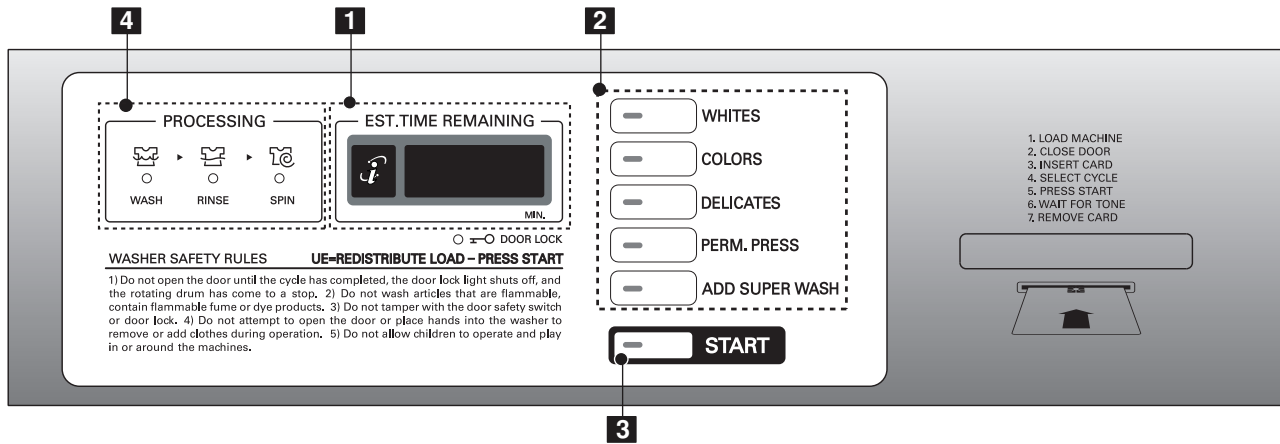

■ COIN TYPE - SIDE BY SIDE (GCW1069QS)

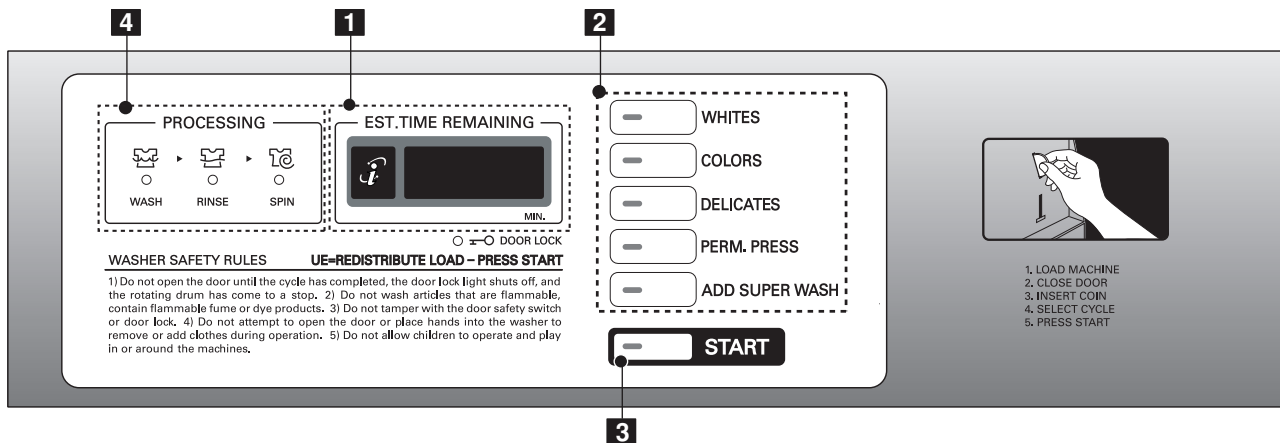

- 1. DISPLAY LED
- 2. CYCLE BUTTON

- 3. START BUTTON
- 4. STATUS BUTTON

STATUS LED

DISPLAY LED

CYCLE BUTTON

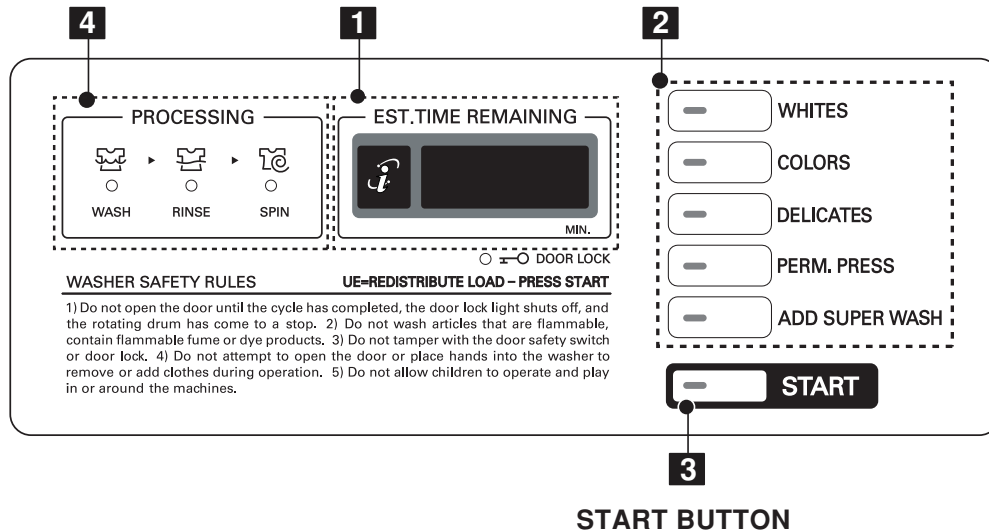

1 Display LED

The display shows the vend price and remaining time and programming options. Error codes are also displayed here.



2 CYCLE BUTTON

Press the CYCLE button to select the desired cycle based on laundry types and conditions.

WHITES

Use for hot washing for heavy fabrics, such as white clothes, table linens, and heavily soiled clothes.

COLORS

Use for warm washing for heavy fabrics, such as jeans, corduroys, or work clothes.

DELICATES

Use for cold washing for synthetic fabrics, such as washable knit fabric and no-iron finishes.





PERMANENT PRESS

Use for warm washing for sturdy fabrics, such as work casual work.

3 START BUTTON

The START LED flashes when the full vend price has been satisfied and the cycle has been chosen.

4 STATUS LED

-  LED flashes whenever the washing cycle is in operation.
-  LED flashes whenever the Rinsing cycle is in operation.
-  LED flashes whenever the Spining cycle is in operation.
-  LED flashes whenever the door lock is activated.

■ **Select cycles designed for different types of fabric and soil levels**

CYCLE	Fabric type	Wash/Rinse Temp.	Spin Speed	Add Super Wash
Whites	Cotton, Linen, Towels, Shirts, Sheets	Hot/Cold	High	O
Colors	Mixed Loads, Work Clothes, Jeans, Shirts	Warm/Cold	High	O
Delicates	Dress Shirts/Blouses, Nylons, Sheer or Lacy Garment	Cold/Cold	Low	O
Perm Press	Dress Shirts/Pants, Wrinkle Free Clothing, Poly/Cotton Blend Clothing, Tablecloths.	Warm/Cold	Medium	O

Add super wash

- Adds an additional 3 minutes of washing time and an extra rinse

7. WIRING DIAGRAM/PROGRAM CHART

■ Card Type : GCW1069QD GCW1069QS

■ Coin Type : GCW1069CD GCW1069CS

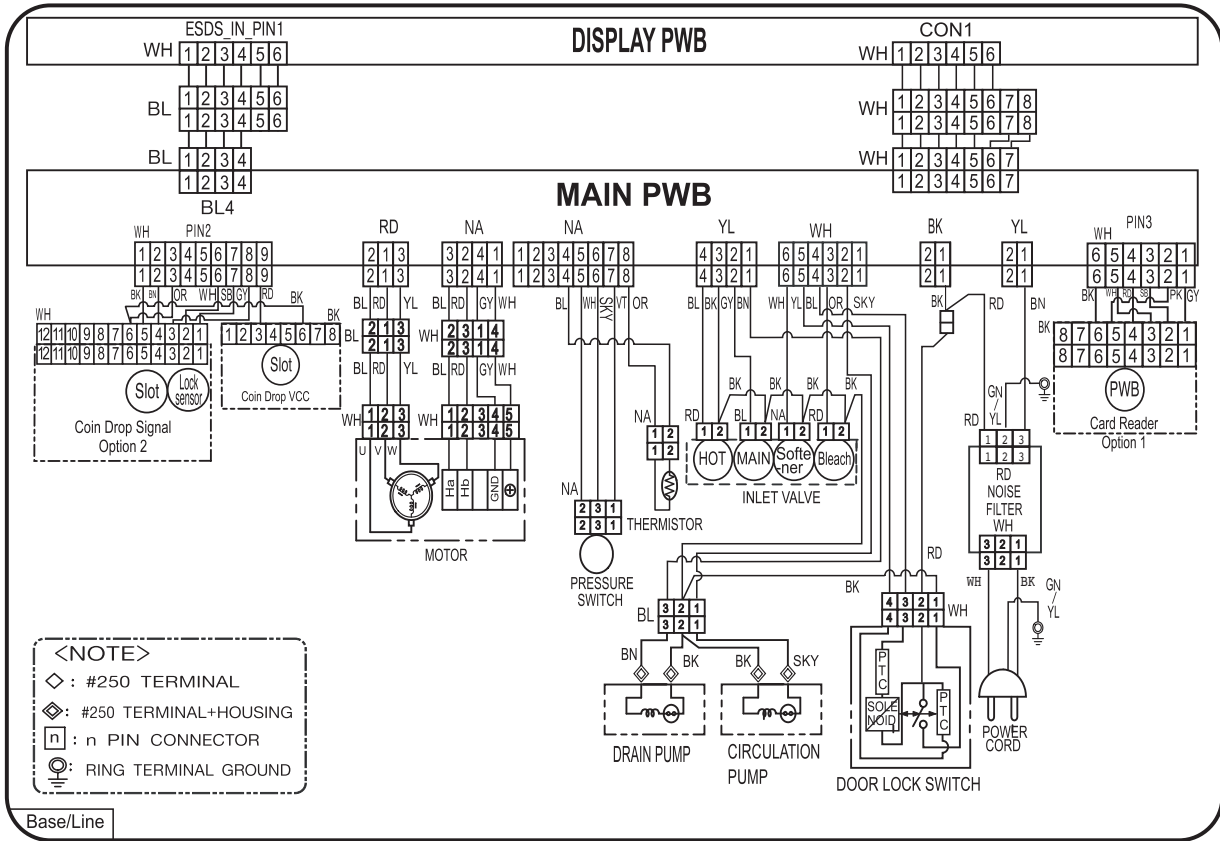

■ Program Chart

COURSE STEP Time (sec)	WASH 9min		RINSE 15min												SPIN 13min			INITIAL STAGE	Approx. Working Time (min)	
	W / S	WASH	NORMAL						SUPER CYCLE						DRAIN	SPIN	D / T			END
			1		2		3		DRAIN	SPIN	D / T									
			DRAIN	1 / S	W / S	RINSE	DRAIN	1 / S				W / S	RINSE							
1	2	3	4	5	6	7	8	9	10	11	12	13	14	15	16	17	18	19		
120	*	120	180	120	60	60	180	120	60	60	180	120	60	60	*	60	~	~		
WHITES	7														360 660					37
COLORS	7														360 660					37
PERM PRESS	7														180 420					33
DELICATES	7														180 420					33

Basic Cycle
 Optional Cycle

*-> time is in minutes

- Water Supply : W/S
- Intermittent Spin : 1/S
- Disentangle : D/T

8. TROUBLESHOOTING

8-1. BEFORE PERFORMING SERVICE

- Be careful of electric shock when disconnecting parts while troubleshooting.
- The voltage of each terminal is 120V~ when the unit is plugged in.

8-2. QC TEST MODE.

The washer must be empty.

■ Card Type

1. Insert Service Card
2. **L9C1** Display
3. Press the **Start** button repeatedly to cycle through the test modes.

■ Coin Type

1. Turn on/off toggle switch
2. **L9C1** Display
3. Press the **Start** button repeatedly to cycle through the test modes.

Number of times the START button is pressed	Check Point	Display
None		L9C1
1 time	Turns on all lamps and locks the door	Displayed gc XX and US XX alternately (Version)
2 times	Tumble Clockwise.	rpm (40~50)
3 times	Low Speed Spin	rpm (600)
4 times	High Speed Spin	rpm(1000~1100)
5 times	Inlet valve for main water turns on.	Water level frequency (261~)
6 times	Inlet valve for hot wash turns on.	Water level frequency (261~)
7 times	Inlet valve for softener turns on.	Water level frequency (261~)
8 times	Inlet valve for bleach turns on.	Water level frequency (261~)
9 times	Tumble counter clockwise.	rpm (40~50)
10 times	Drain Pump turns on	Water level frequency (261~)
11 times	Turn on Circulation Pump	Displayed 0XX
12 times	Turns on all lamps.	Displayed gc XX and US XX alternately
13 times	Button Checks.	Displayed gc XX and US XX alternately
14 times	High Speed Spin	rpm (1100)
15 times	Lr--- PDA Signal Check	Lr--- This function is not applied in this machine
16 times		L9C1

8-3. HOW TO CHECK THE WATER LEVEL FREQUENCY

- Press and hold the ADD SUPER WASH and PERMANENT PRESS buttons simultaneously.



- When you check the water level, the first digit is a 0 which means 2.
A display indicating 041 is a water level frequency of 241 multiplied by 0.1 KHz , for an actual frequency of 24.1 KHz.

8-4. HOW TO CHECK THE RPM



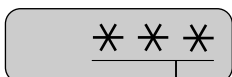



- Press the ADD SUPER WASH AND WHITES button simultaneously.





- Under 200 rpm: The display indicates the rpm. (Under 200 rpm)
Over 200 rpm: The display indicates the rpm. (x 10 rpm)
So, for example a display indicating 050 : rpm of 050 x 10 rpm = 500rpm

8-5. ERROR DISPLAY

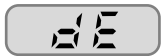
- If you press the START button when an error is displayed, any error except *PE* will disappear and the machine will go into the pause status.

	ERROR	SYMPTOM	CAUSE
1	WATER INLET ERROR		<ul style="list-style-type: none"> • Correct water level (246) is not reached within 10 minutes after water is supplied or it does not reach the preset water level within 12 minutes.
2	IMBALANCE ERROR		<ul style="list-style-type: none"> • The load is too small. • The appliance is tilted. • Laundry is gathered to one side. • Non distributable things are put into the drum.
3	DRAIN ERROR		<ul style="list-style-type: none"> • Not fully drained within 3 minutes.
4	OVER FLOW ERROR		<ul style="list-style-type: none"> • Water is overflowing (water level frequency is over 213). ※ If  is displayed, the drain pump will operate to drain the water automatically.
5	PRESSURE SENSOR ERROR		<ul style="list-style-type: none"> • The SENSOR SWITCH ASSEMBLY is out of order.
6	DOOR OPEN ERROR		<ul style="list-style-type: none"> • Door not all the way closed. • Loose electrical connections at door switch and PWB Assembly. • The DOOR SWITCH ASSEMBLY is out of order.

	ERROR	SYMPTOM	CAUSE
7	LOCKED MOTOR ERROR		<ul style="list-style-type: none"> • The connector (3-pin, male, white) in the MOTOR HARNESS is not connected to the connector (3-pin, female, white) of STATOR ASSEMBLY. • The electric contact between the connectors (3-pin, male, white) in the MOTOR HARNESS and 4-pin, female, white connector in the MAIN PWB ASSEMBLY is bad or unstable. • The MOTOR HARNESS between the STATOR ASSEMBLY and MAIN PWB ASSEMBLY is cut (open circuit). • The hall sensor is out of order/defective.
8	EEPROM ERROR		<ul style="list-style-type: none"> • EEPROM is out of order. ※ Displayed only when the START button is first pressed in the QC Test Mode.
9	CARD READER ERRER		<ul style="list-style-type: none"> • Disconnection of Card Reader Wire.

8-6. DISPENSER

The dispenser drawer is a multi-chambered reservoir that allows the user to add all the appropriate laundry additives before starting the cycle. It has a place for pre-wash and Main wash detergent, fabric softener, and bleach. Powdered or liquid detergents may be use, but softener and bleach must be liquids.

Detergents should carry the HE designation. Do not use regular detergents in the washer or overusing will occur. Regular detergents also cause a scum build-up in the tub, which leads to poor performance and a foul odor.

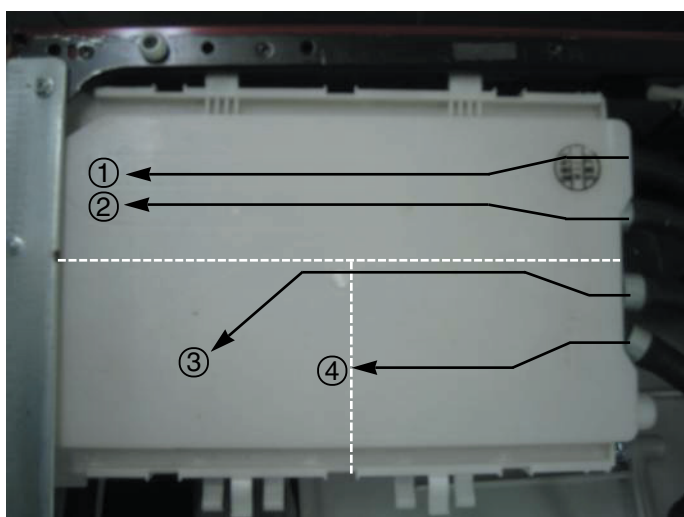

- ① HOT INPUT
- ② MAIN WASH
- ③ BLEACH
- ④ SOFTNER

9. DIAGNOSIS AND TROUBLESHOOTING

⚠ WARNING

1. Be careful of electric shock if disconnecting parts while troubleshooting.
2. First, check the connection of each electrical terminal with the wiring diagram.
3. If you replace the MAIN PWB ASSEMBLY, reinsert the connectors correctly.

NO POWER

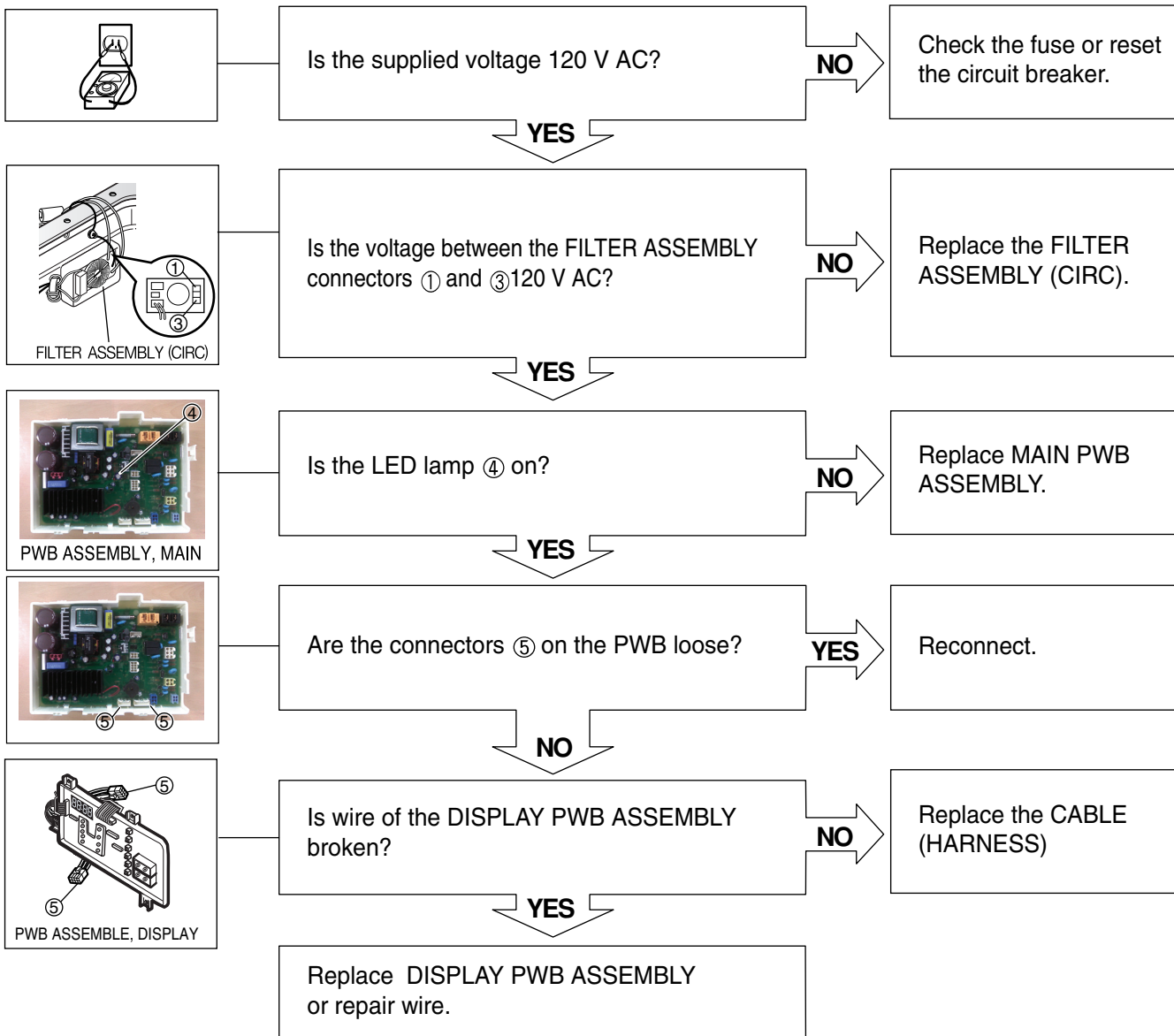

IE ERROR (NO WATER SUPPLY)

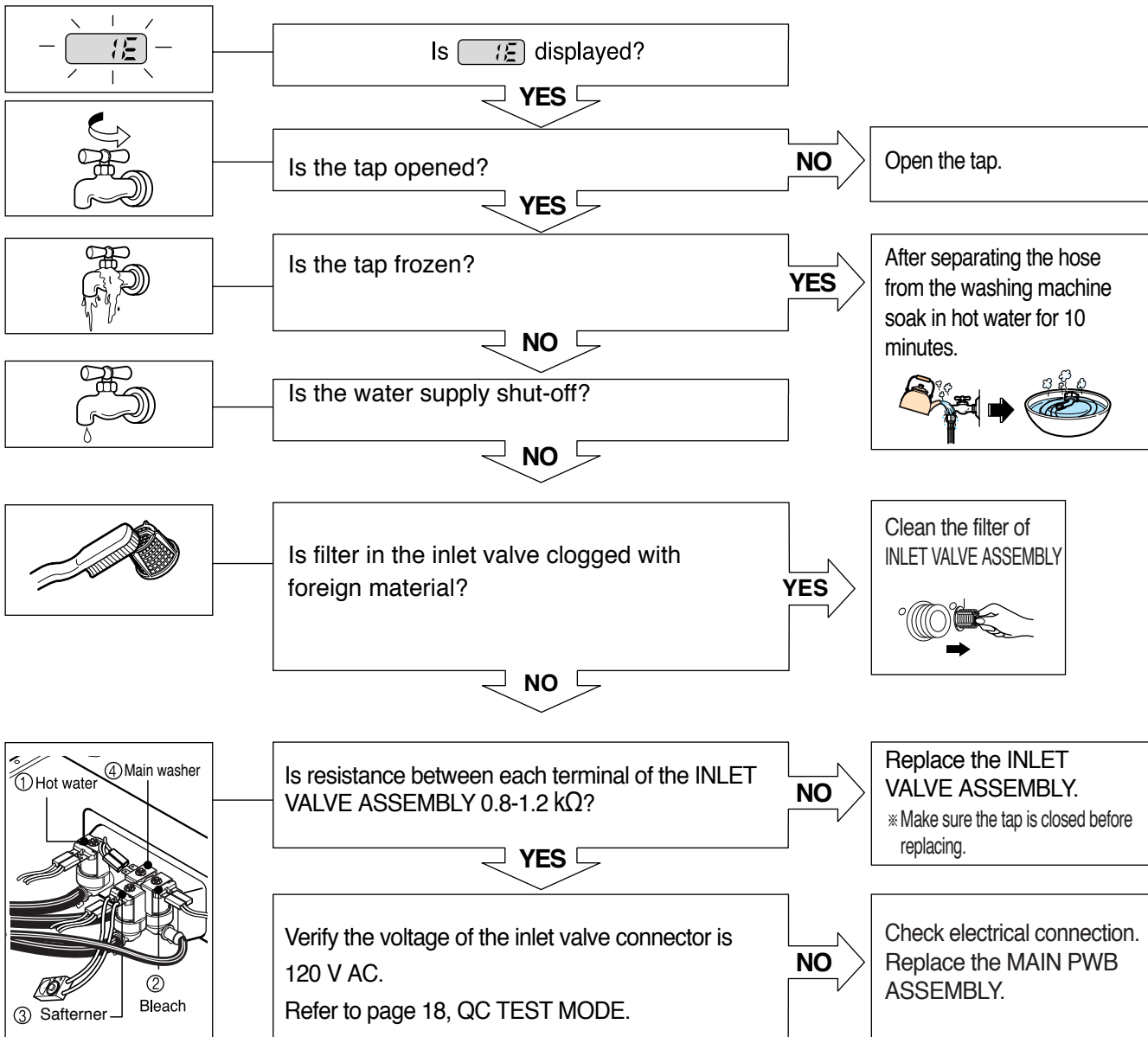

OE ERROR (DRAIN TROUBLE)

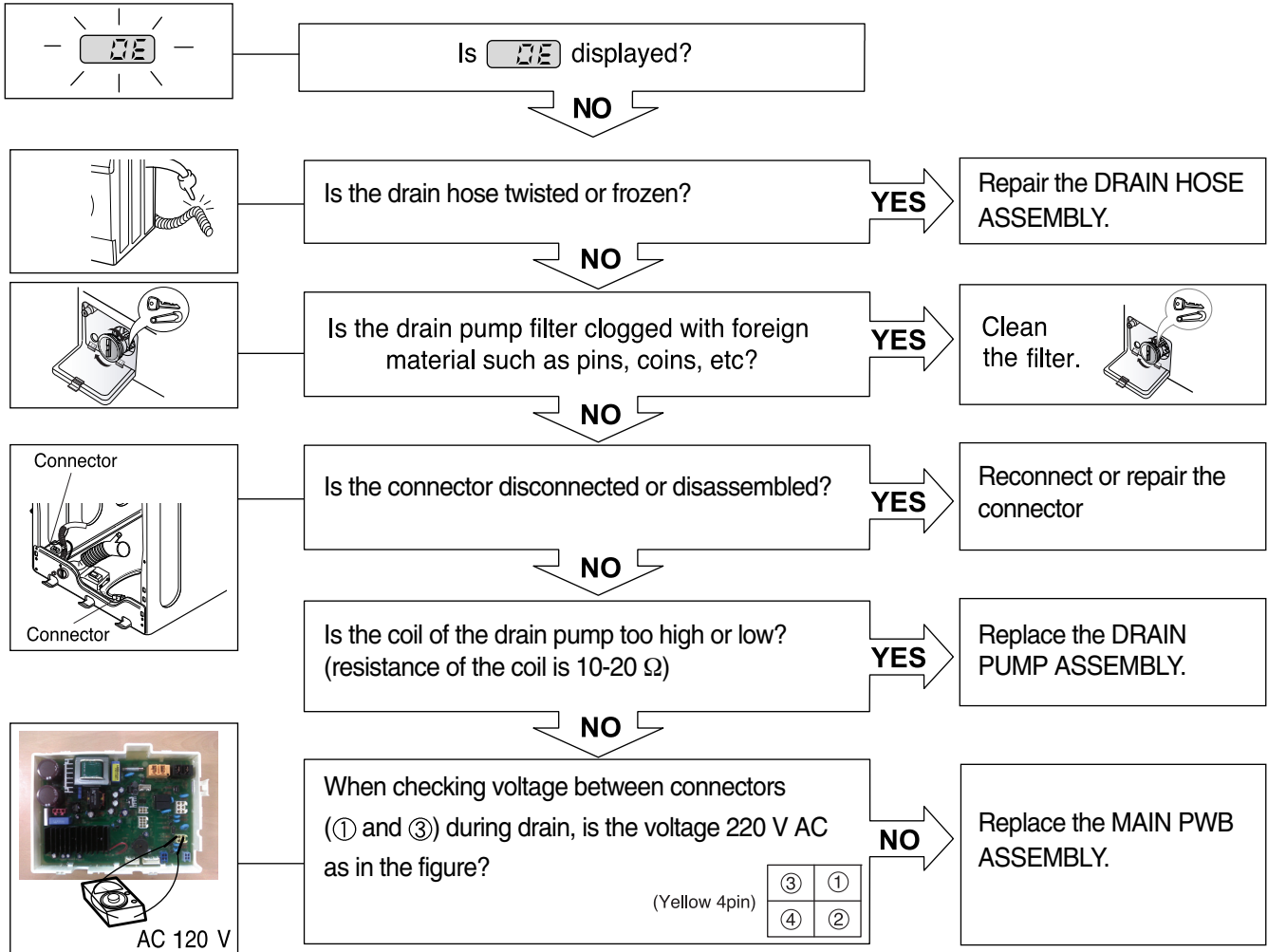

FE ERROR

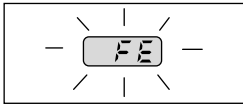

Is **FE** displayed?

YES

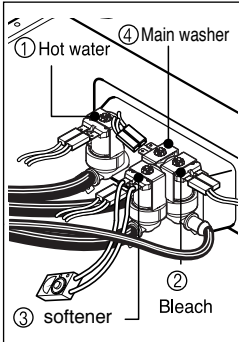

Is resistance between each terminal of INLET VALVE ASSEMBLY 0.8~1.2kΩ?

NO

YES

Is water continuously supplied?

YES

NO

Replace the INLET VALVE ASSEMBLY.
※ Make sure the tap is closed before replacing.

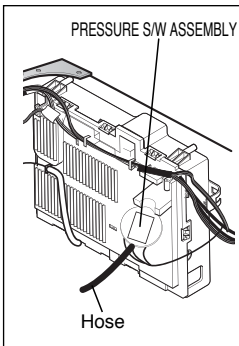

Is PRESSURE SW ASSEMBLY broken?

YES

NO

Check electrical connection.
Replace the MAIN PWB ASSEMBLY.

Replace the PRESSURE SW ASSEMBLY.

PE ERROR (PRESSURE SW TROUBLE)

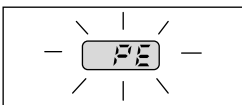

Is **PE** displayed?

YES

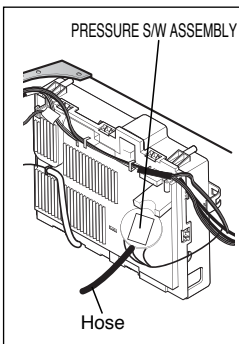

Is PRESSURE SW ASSEMBLY broken?

YES

NO

Check electrical connection.
Replace the MAIN PWB ASSEMBLY.

Replace the PRESSURE SW ASSEMBLY.

dE ERROR (DOOR ERROR)

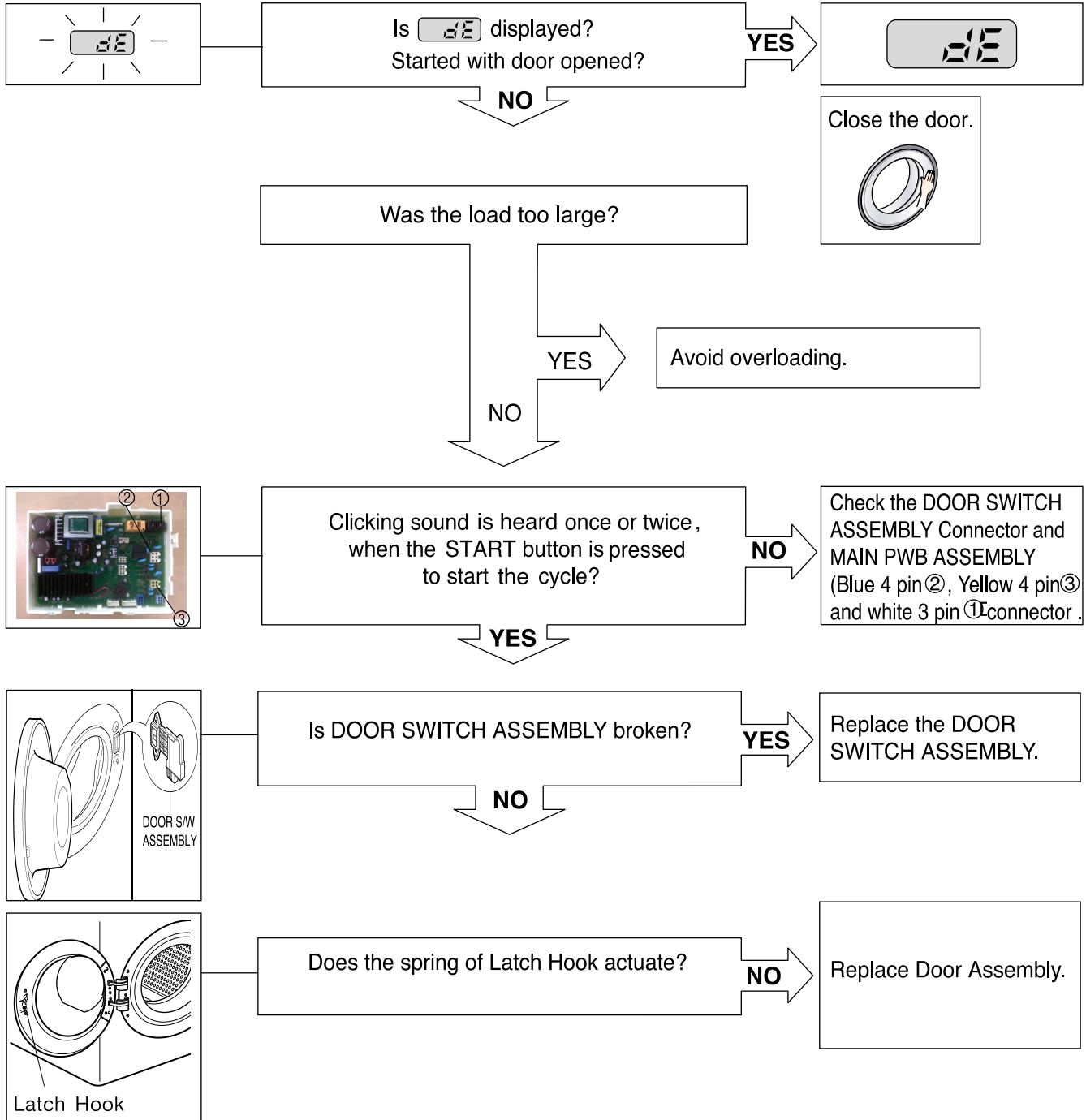

VIBRATION & NOISE IN SPIN

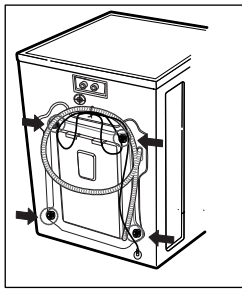

Have all the transit bolts and base packing been removed?

NO

Remove the transit bolts and Base packing.

YES

Is the washer installed on a solidly constructed floor?

NO

Move the washer or reinforce the floor.

YES



Base Packing

Check if the washer is perfectly level as follows:

Level



Check the leveling of the washer with a level and check that the washer is stable.

Put an unbalance part (rubber) inside of drum and start QC test mode and run in high spin (Refer to page 17)
When the machine is spinning in high speed, verify that it is stable.

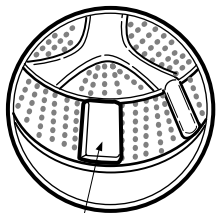

Unbalance Part

If you do not have the unbalance part, put 4.5 to 6.5 lbs (2 to 3 kg) of clothing.

When the machine is spinning at high speed, verify that it is stable.

YES

If it is not stable, adjust feet accordingly. After the washer is level, tighten the lock nuts up against of the base of the washer. All lock nuts must be tightened.

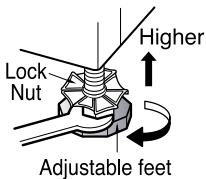

Adjustable feet

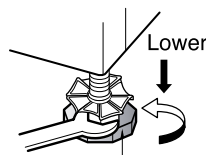

Adjustable feet

DETERGENT/SOFTENER/BLEACH DOES NOT FLOW IN

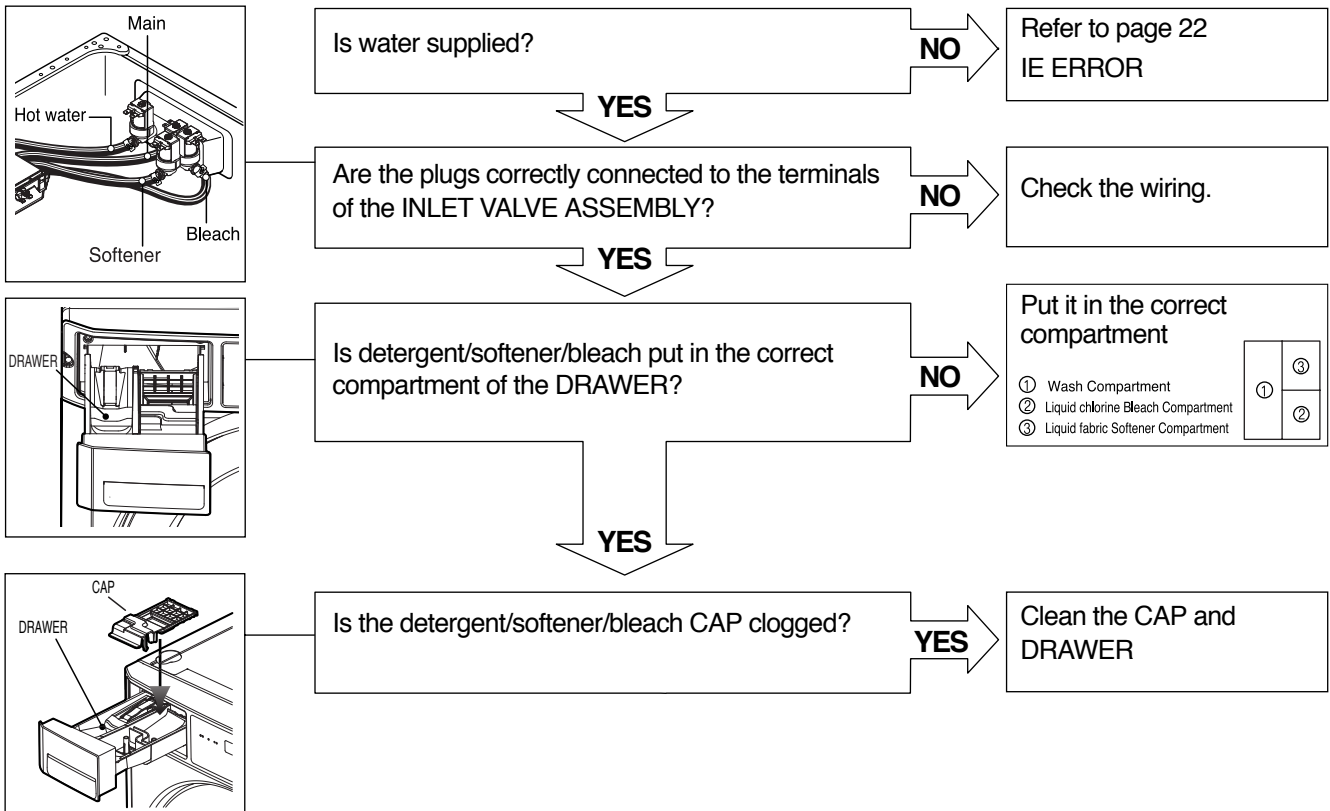

ABNORMAL SOUND

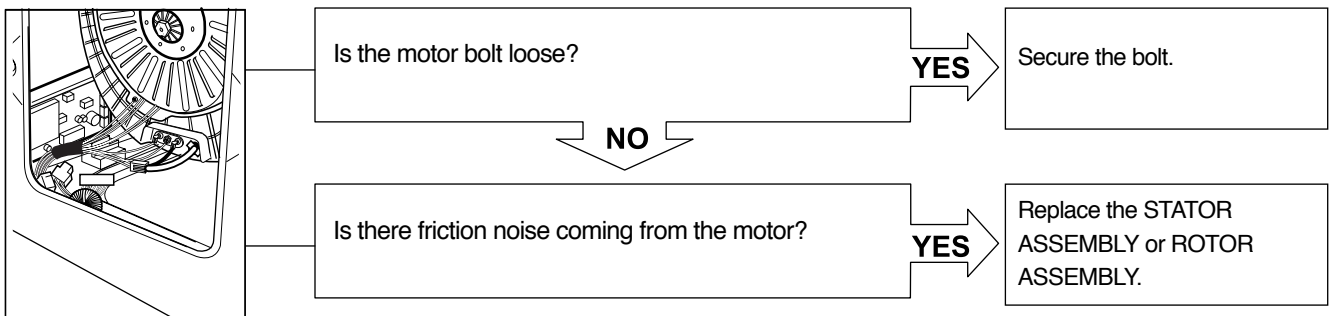

SUDS OVERFLOW FROM THE APPLIANCE



Is HE(High Efficiency) detergent used?

YES

Is the proper amount of detergent used as recommended?

YES

Recommend to reduce the amount of detergent.



- * This appliance has an automatic suds sensing function which prevents overflow.
- * When excessive suds are sensed, the suds removing implementations such as drain, water input, and pause will operate, without rotating the drum

10. DISASSEMBLY INSTRUCTIONS

* Be sure to unplug the machine before disassembling and repairing the parts.

CONTROL PANEL ASSEMBLY

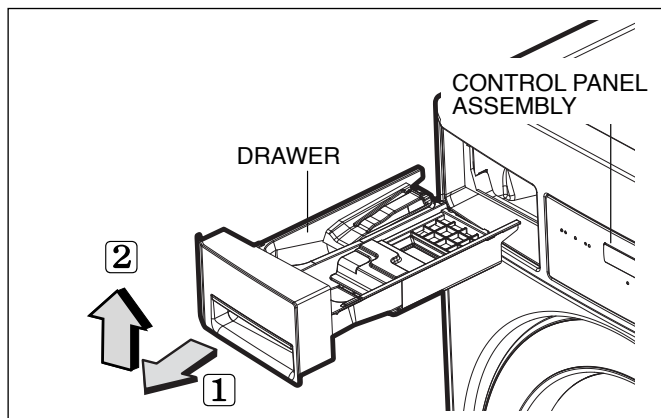

1. Pull out the DRAWER.

* Do not pull out the DRAWER too forcefully as it can be broken.

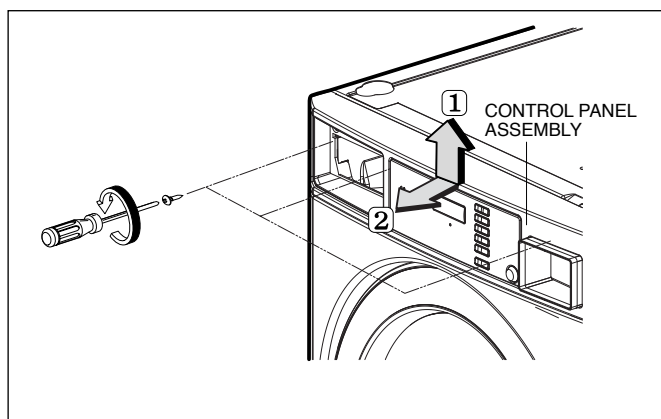

2. Unscrew 3 screws

3. Disassemble the CONTROL PANEL ASSEMBLY

- Pull out the CONTROL PANEL .

* Do not pull out the CONTROL PANEL too forcefully as it can be broken.

4. Disconnect the DISPLAY PWB ASSEMBLY connector from CABLE (HARNES).

DISPLAY PWB ASSEMBLY

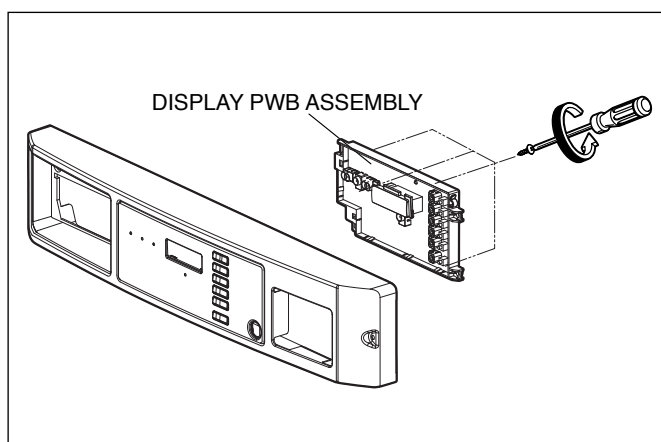

1. Disassemble the CONTROL PANEL ASSEMBLY

2. Unscrew the 4 screws from the CONTROL PANEL ASSEMBLY.

3. Disassemble the DISPLAY PWB ASSEMBLY.

TOP PLATE ASSEMBLY

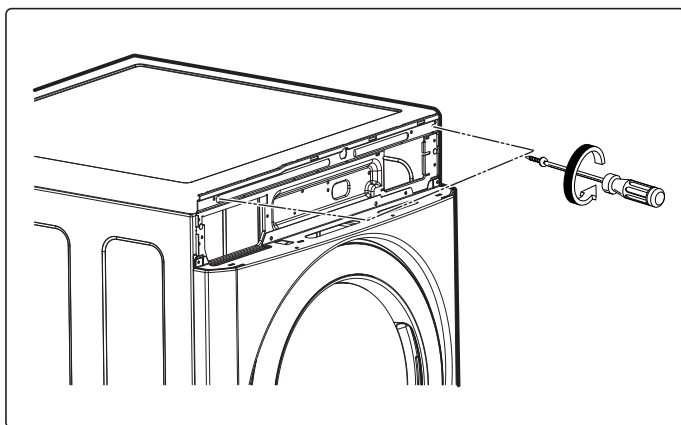

⚠ WARNING

- When you disassemble the top plate, be sure to take gloves and careful plate's edge. Failure to do so can cause serious injury.

1. Disassemble the CONTROL PANEL ASSEMBLY (refer to page 30)
2. Remove 2 screws on the CONTROL PANEL frame.

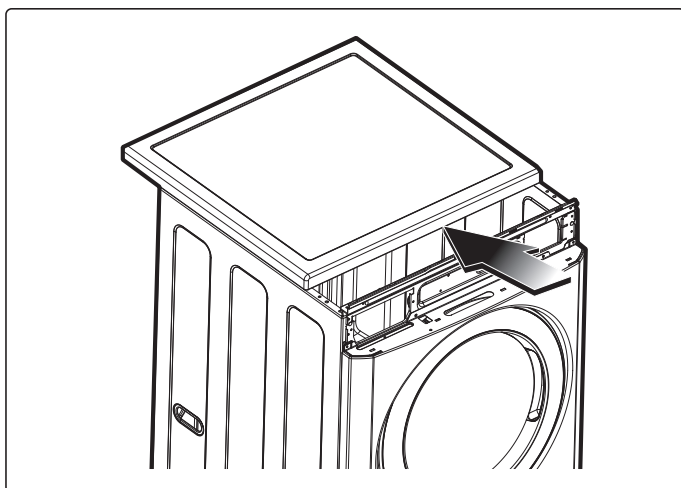

3. Push the TOP PLATE backward forcefully.

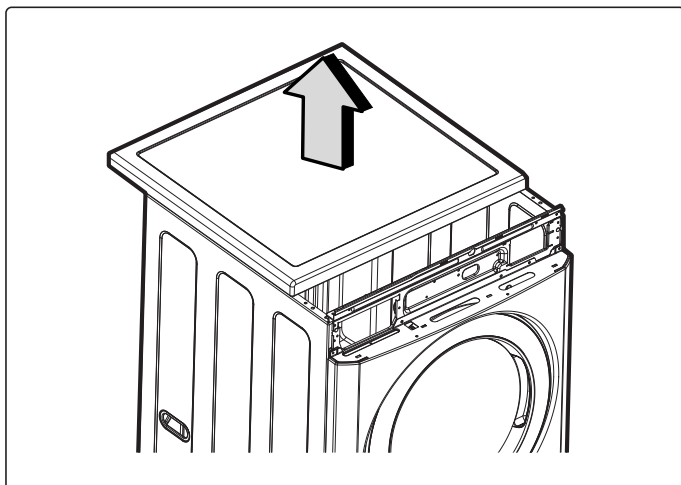

4. Lift the TOP PLATE.

MAIN PWB ASSEMBLY

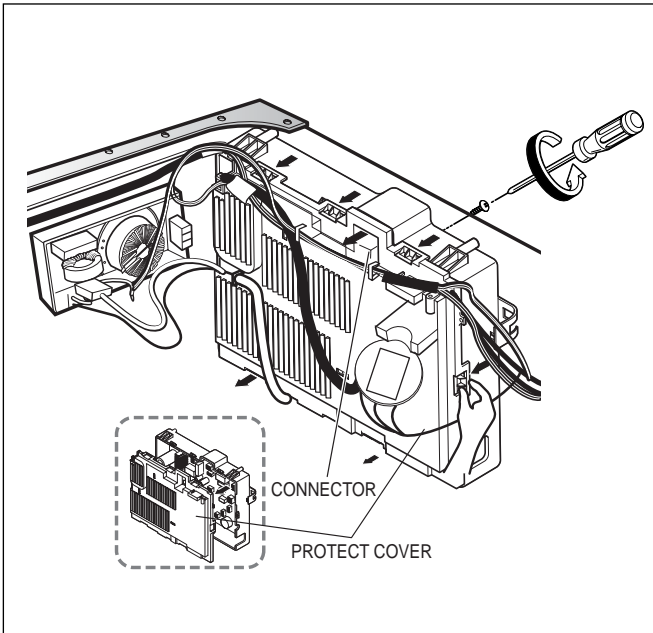

1. Disassemble the CONTROL PANEL ASSEMBLY (refer to page 30).
2. Disassemble the TOP PLATE ASSEMBLY (refer to page 31).
3. Unscrew a screw on PRESSURE SWITCH ASSEMBLY
4. Remove all wire from hooks.
5. Remove the Protective Cover.

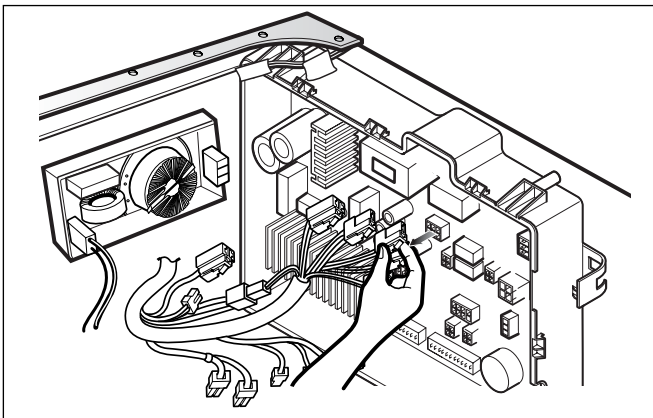

6. Disconnect the connectors.

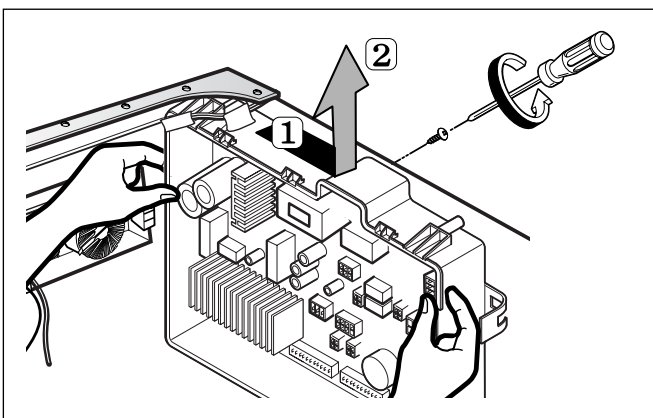

7. Unscrew 1 screw on the back.
8. Disassemble the MAIN PWB ASSEMBLY.

DISPENSER ASSEMBLY

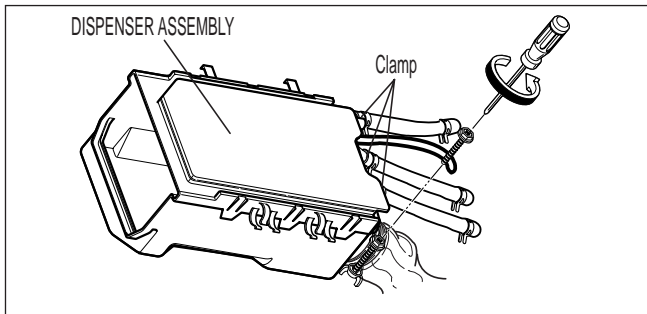

1. Disassemble the CONTROL PANEL ASSEMBLY (refer to page 30).
2. Disassemble the TOP PLATE ASSEMBLY (refer to page 31).
3. Disassemble the clamps and hoses.
4. Disassemble the bellows at the lower side of DISPENSER

INLET VALVE ASSEMBLY

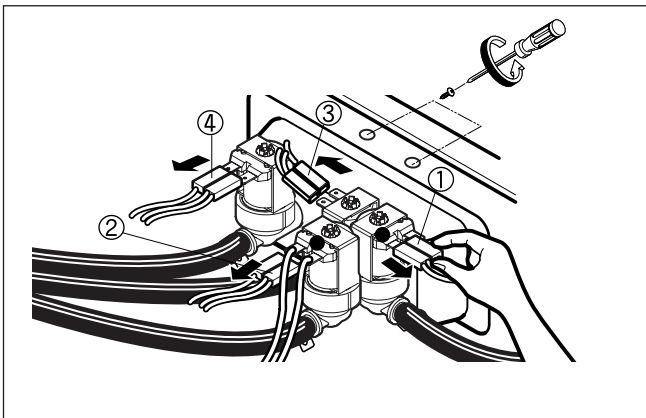

1. Disassemble the CONTROL PANEL ASSEMBLY (refer to page 30).
2. Disassemble the TOP PLATE ASSEMBLY (refer to page 31).
3. Disassemble the 4 connectors from the VALVES.
4. Disassemble the clamps and hoses.
5. Unscrew the 2 screws in the back.

Connector Color

- ① Blue Housing (OR-BK)
- ② White Housing (WH-BK)
- ③ Blue Housing (GY-BK)
- ④ Red Housing (BL-BK)

CABINET COVER

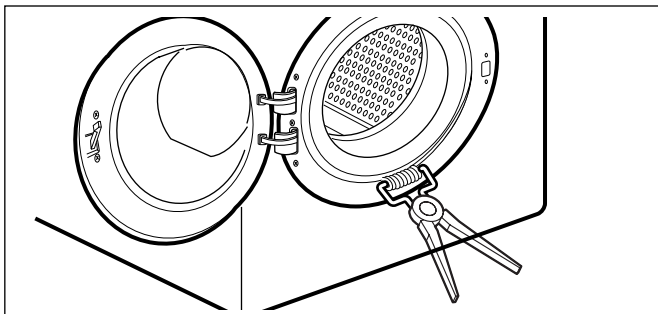

1. Disassemble the CONTROL PANEL ASSEMBLY (refer to page 30).
2. Open the DOOR.
3. Disassemble the CLAMP ASSEMBLY.

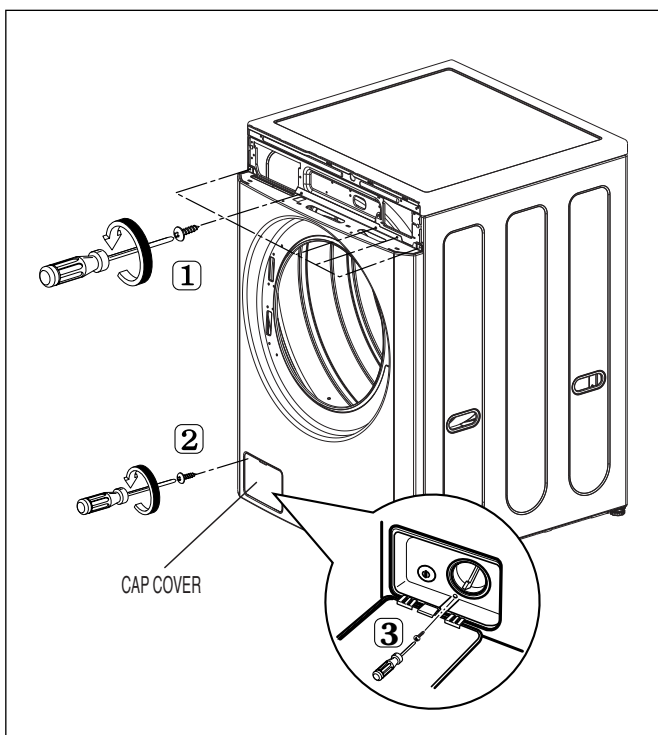

4. Unscrew the 5 screws from the CABINET COVER.
5. Unscrew the screw from CAP COVER.
6. Unscrew the screw from inside CAP COVER.

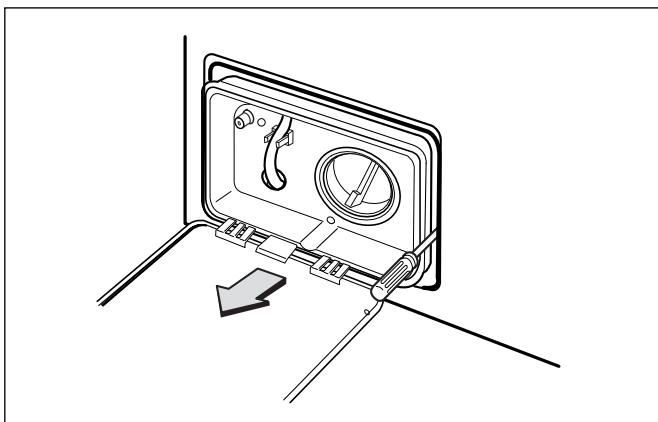

7. Put a flat (-) screwdriver or putty knife into both sides of the CAP COVER, and pull it out.

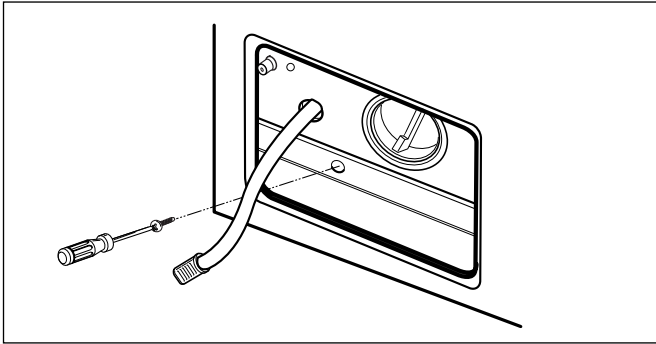

8. Unscrew the screw from the lower side of the CABINET COVER.

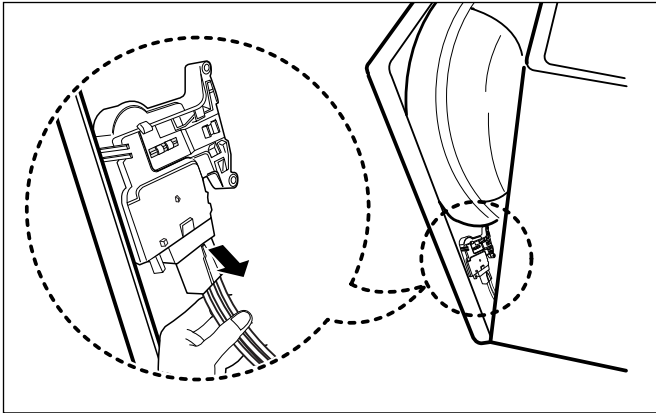

9. Tilt the CABINET COVER.
10. Disconnect the DOOR S/W connector.

※ **NOTE:** When assembling the CABINET COVER, connect the connector.

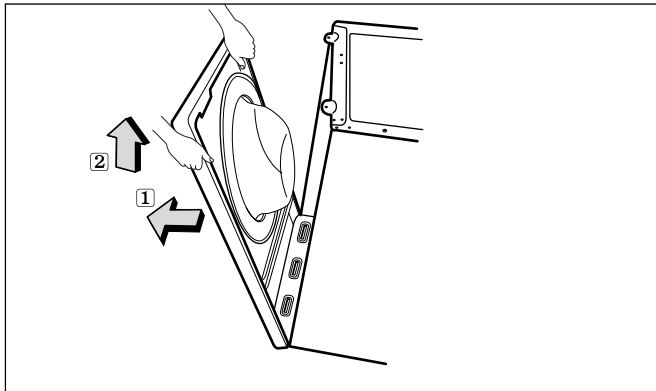

11. Lift and separate the CABINET COVER.

GASKET

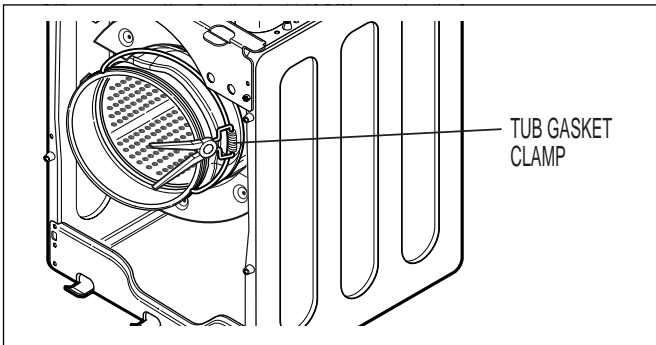

1. Disassemble the CABINET COVER
(refer to page 34).
2. Disassemble the CLAMP ASSEMBLY.
3. Disassemble the GASKET.

DOOR ASSEMBLY

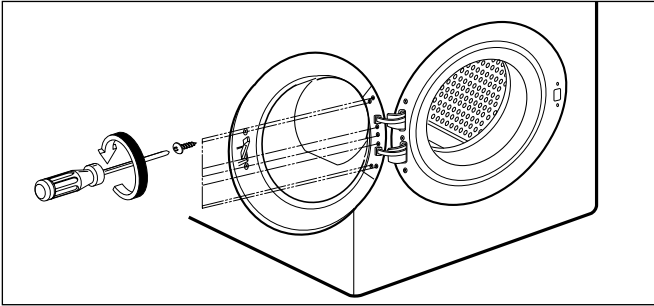

1. Open the DOOR.
2. Unscrew the 7 screws from the HINGE COVER.

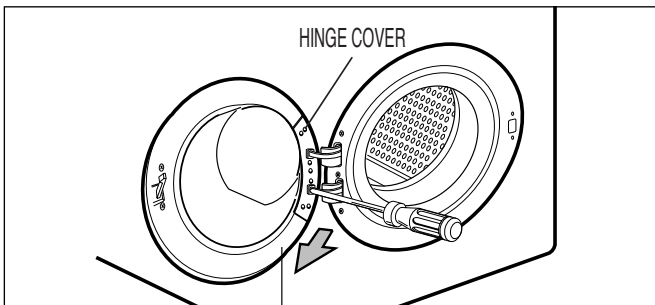

3. Put a flat (-) screwdriver into the opening of the hinge, and pull out the HINGE COVER.

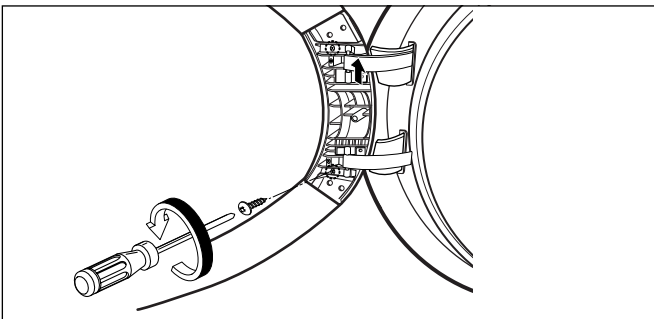

4. Unscrew a screw from the lower side of DOOR.
5. Lift door and remove.

※ **Be careful!** The door is heavy.

DOOR LOCK SWITCH ASSEMBLY

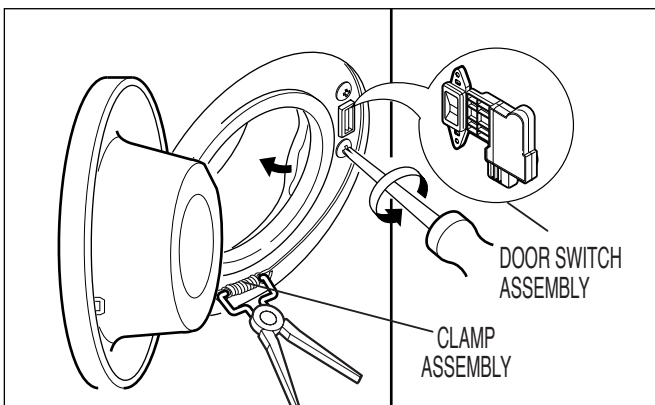

1. Open the DOOR and disassemble the CLAMP ASSEMBLY.
2. Unscrew the 2 screws.
3. Remove connector from DOOR SW ASSEMBLY.

※ **NOTE**

- Reconnect the connector after replacing the DOOR SWITCH ASSEMBLY.

PUMP ASSEMBLY

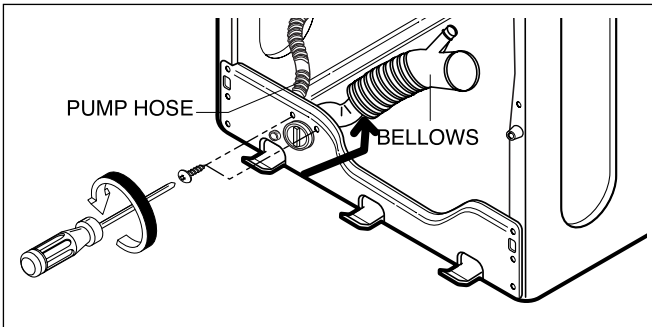

1. Disassemble the CABINET COVER (refer to page 34).
2. Separate the PUMP HOSE and the BELLOWS from the PUMP ASSEMBLY.
3. Unscrew 2 screws.
4. Remove the PUMP ASSEMBLY in arrow direction.

THERMISTOR

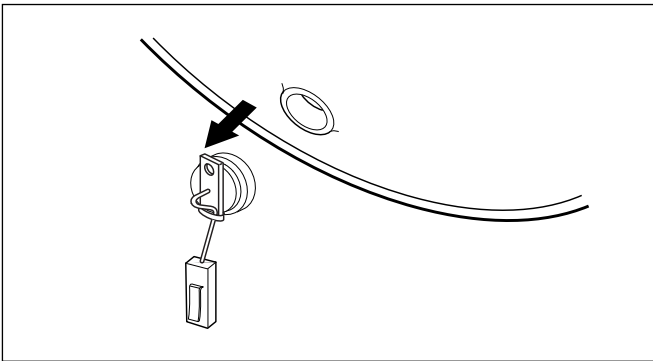

1. Disassemble the CABINET COVER (refer to page 34).
2. Unplug the white connector from the THERMISTOR.
3. Pull it out by holding the bracket of the THERMISTOR.

NOISE FILTER

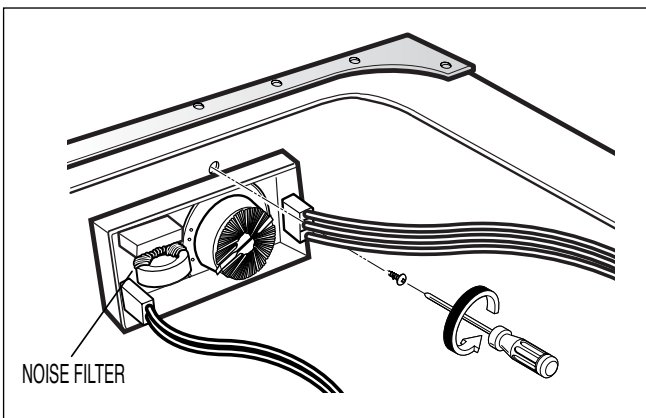

1. Disassemble the CONTROL PANEL ASSEMBLY (refer to page 30).
2. Disassemble the TOP PLATE ASSEMBLY (refer to page 31).
3. Disassemble two (or three) connectors from the NOISE FILTER.
4. Unscrew a screw from the TOP BRACKET.

MOTOR ASSEMBLY

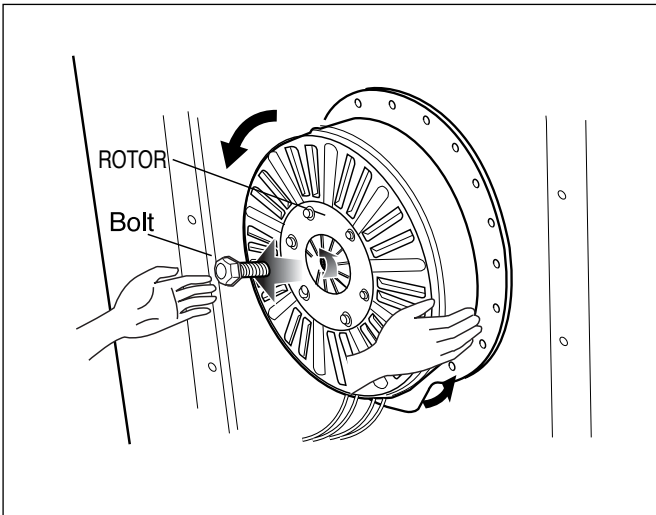

1. Disassemble the BACK COVER.
2. Remove the bolt.
3. Pull out the ROTOR.

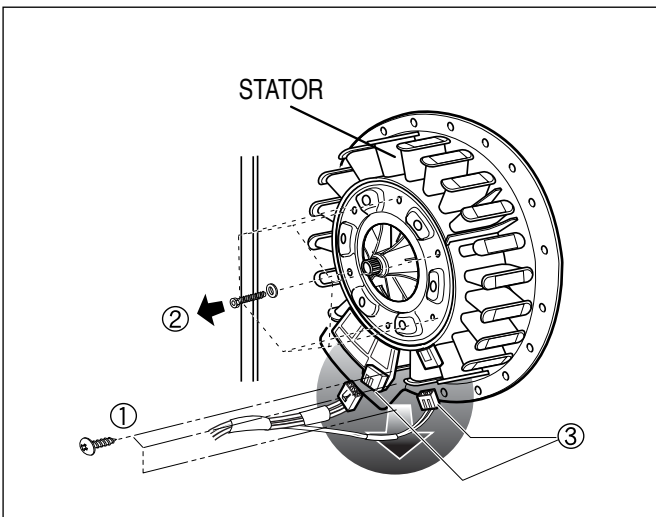

4. Unscrew the 2 screws from the tub bracket.
5. Remove the 6 bolts on the stator.
6. Unplug the 2 connectors from the STATOR.

DAMPER

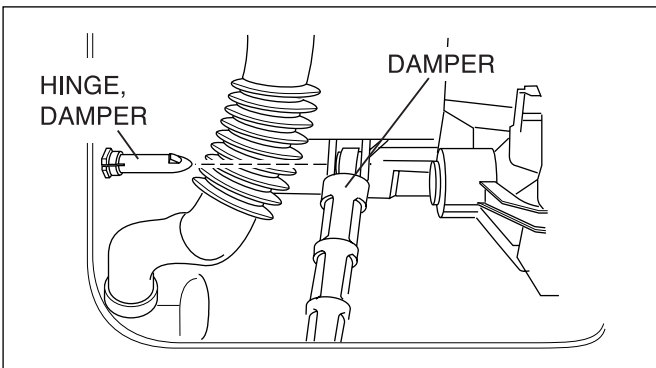

1. Disassemble the CABINET COVER or BACK COVER.
2. Disassemble the damper hinges from the tub and base.
3. Separate the dampers.

※ NOTE

- Do not re-use an old damper pin. Always replace it with a new one.

11. EXPLODED VIEW

11-1-1. CABINET & CONTROL PANEL ASSEMBLY - COIN TYPE

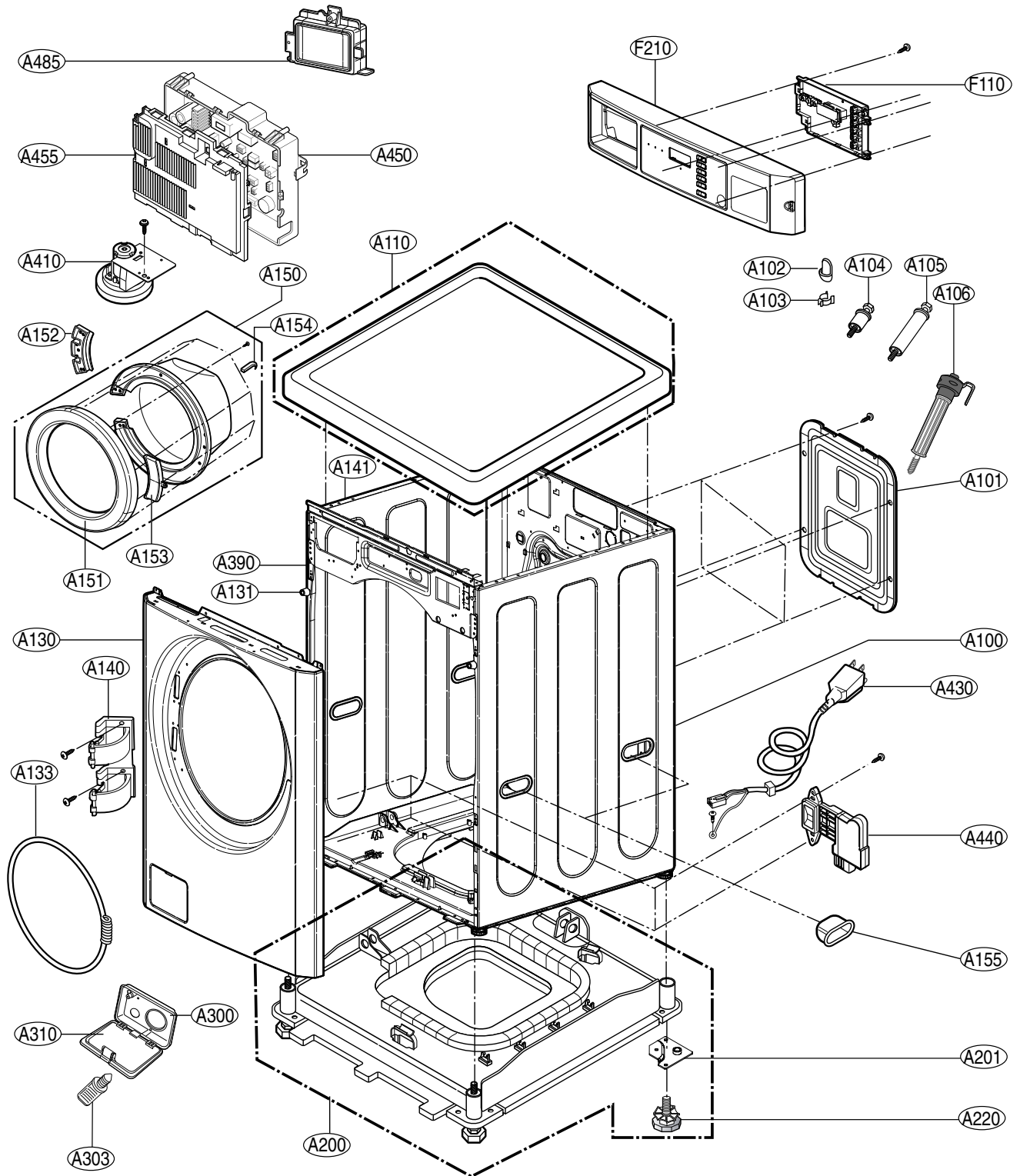

11-1-2. CABINET & CONTROL PANEL ASSEMBLY - CARD TYPE

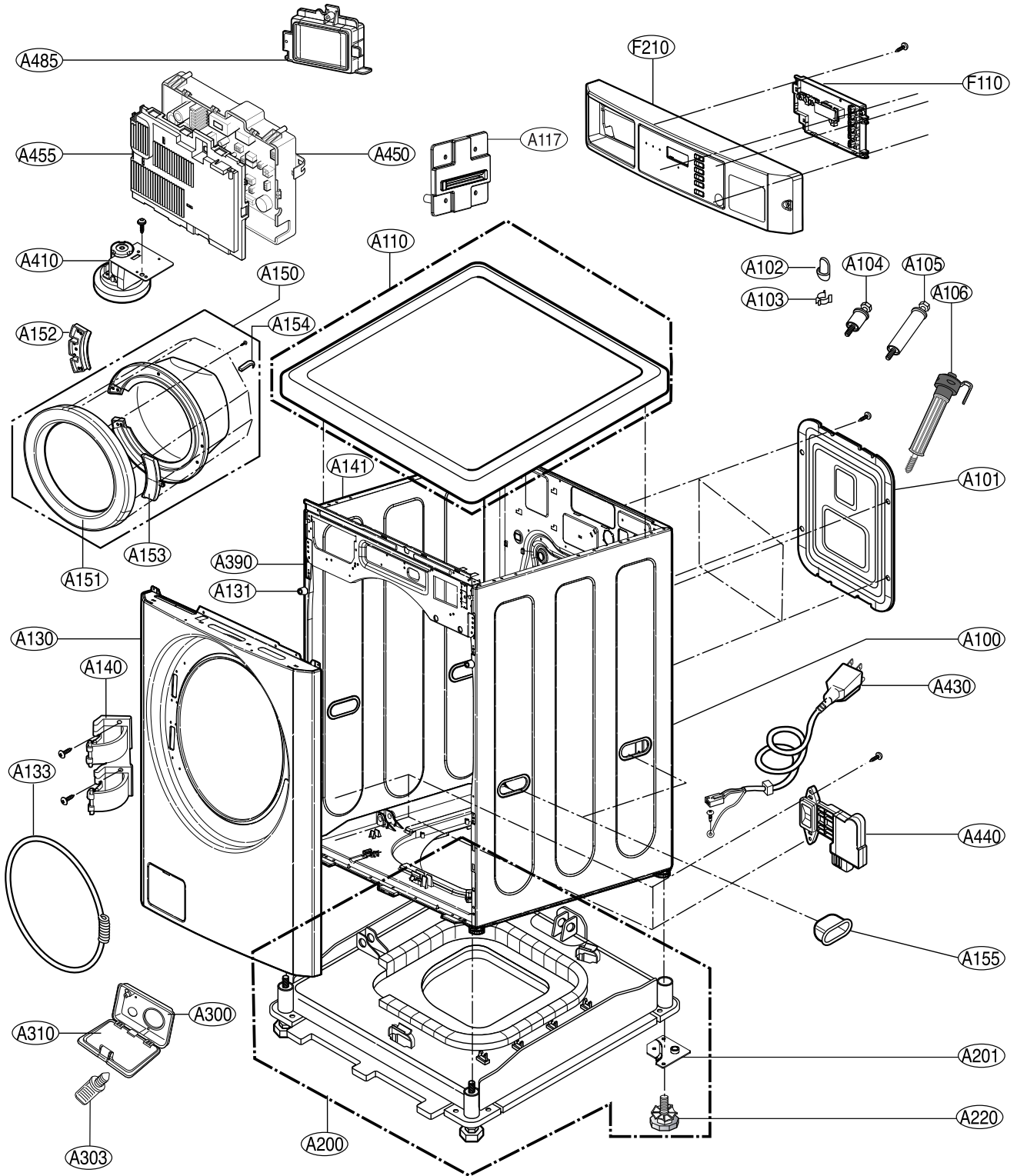

11-2. DRUM & TUB ASSEMBLY

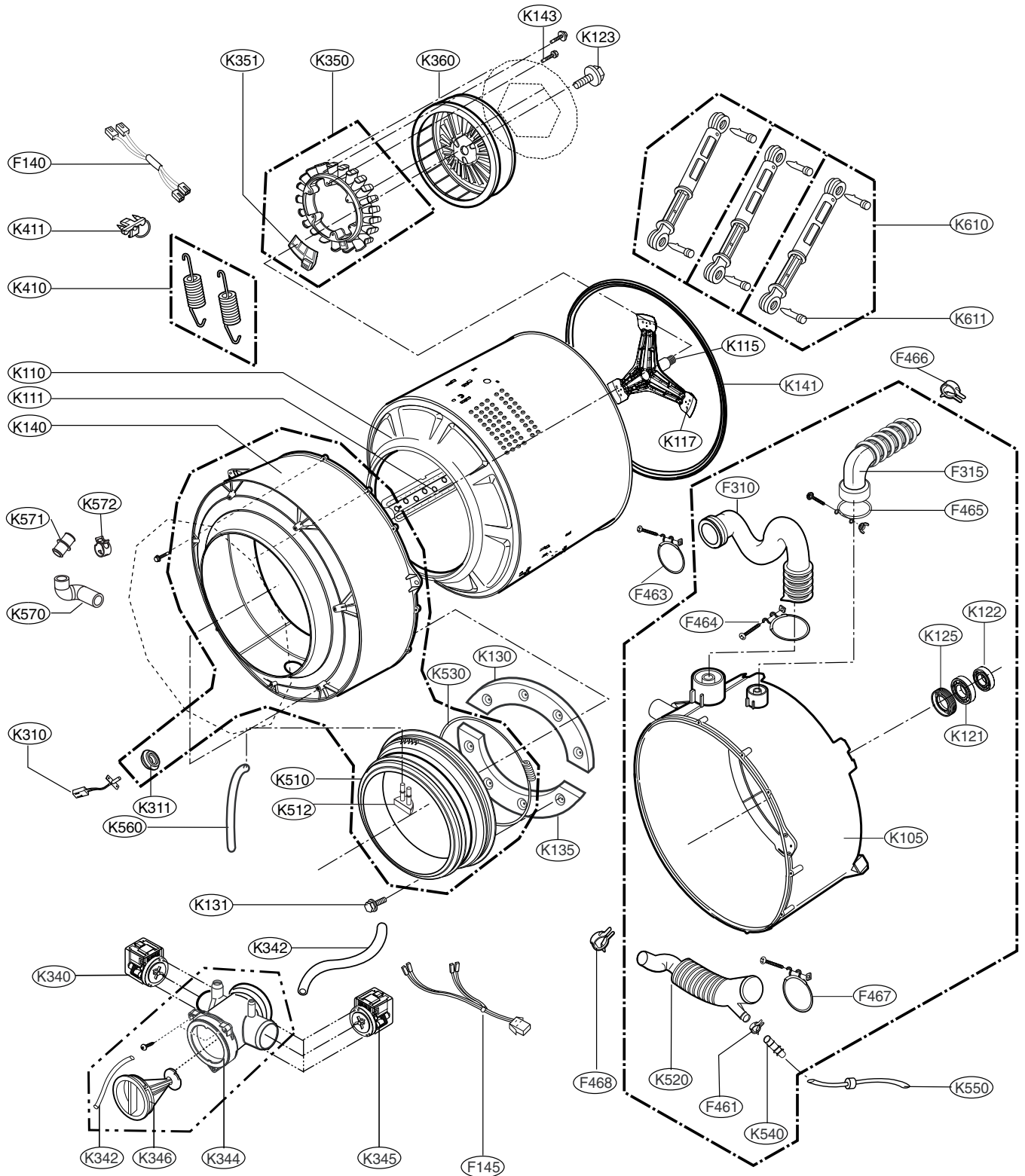

11-3. DISPENSER ASSEMBLY

