

This Owner's Manual is provided and hosted by [Appliance Factory Parts](#).



LG WM2601HW Owner's Manual

[Shop genuine replacement parts for LG WM2601HW](#)



[Find Your LG Washer Parts - Select From 393 Models](#)

----- Manual continues below -----



Website:<http://biz.lgservice.com>

WASHING MACHINE SERVICE MANUAL

▲ CAUTION

READ THIS MANUAL CAREFULLY TO DIAGNOSE
PROBLEMS CORRECTLY BEFORE SERVICING THE UNIT.

MODEL: WM2601H*

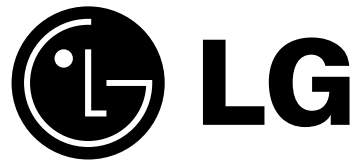

MAY. 2008 PRINTED IN KOREA

P/No.: MFL30599131

CONTENTS

1. Specifications	5
2. Features & Technical Explanation	6-8
3. Parts Identification	9
4. Installation & Test	10-12
5. Operation	13-19
5-1. Control Panel Features	13-15
5-2. Cycle Guide	16
5-3. Special Functions	17
5-4. Explanation of Each Process	18-19
6. Wiring Diagramt	20
7. Test Mode	21
7-1. Safety Caution	21
7-2. Load Test Mode	21
7-3. How to check the water level frequency	21
8. Troubleshooting	22-37
8-1. Safety Caution	22
8-2. Error Mode Summary	22-23
8-3. Troubleshooting Summary	24
8-4. Troubleshooting With Error	25-31
8-5. Troubleshooting Else	32-37
9. Component Testing Information	38-49
9-1. Filter Assembly (Line Filter)	38
9-2. Door Lock Switch Assembly	39-40
9-3. Stator Assembly	41-43
9-4. Pump Motor Assembly	44
9-5. Inlet Valve Assembly	45
9-6. Heater Assembly	46
9-7. Thermistor Assembly	47-48
9-8. Vibration sensor assembly	49
10. Disassembly Instructions	50-58
11. Exploded View	59-61
11-1. Cabinet & Control Panel Assembly	59
11-2. Drum & Tub Assembly	60
11-3. Dispenser Assembly	61

1. SPECIFICATIONS

ITEM		WM2601H*
COLOR		W:BLUE WHITE, R:WILD CHERRY, L:PACIFIC BULE
POWER SUPPLY		AC 120 V, 60 Hz
PRODUCT WEIGHT		197.3 lbs (89.5kg)
ELECTRIC POWER CONSUMPTION	WASHING	280 W
	DRAIN MOTOR	80 W
	WASH HEATER	1000 W
REVOLUTION SPEED	WASH	46 rpm
	SPIN	0-1200 rpm
CYCLES		9
WASH/RINSE TEMPERATURES		5
SPIN SPEEDS		5
OPTIONS		Stain Cycle, Extra Rinse, Water Plus, Wash/Rinse, Optimizer, Rinse+Spin, Prewash, Delay Wash, Custom PGM, Child Lock, Tub Clean
WATER CIRCULATION		Incorporated
OPERATIONAL WATER PRESSURE		14.5-116 psi (100-800 kPa)
CONTROL TYPE		Electronic
WASH CAPACITY [cu.ft]		3.87 (4.0 IEC)
DIMENSIONS		27"(W) X 29 ³ / ₄ "(D) X 38 ¹¹ / ₁₆ "(H), 50 ¹³ / ₁₆ " (D, door open)
DELAY WASH		up to 19 hours
DOOR SWITCH TYPE		PTC + Solenoid
WATER LEVEL		10 steps (by sensor)
LAUNDRY LOAD SENSING		Incorporated
ERROR DIAGNOSIS		Incorporated
AUTO POWER OFF		Incorporated
CHILD LOCK		Incorporated
RLM ENABLE		Incorporated
STEAM		Incorporated

2. FEATURES & TECHNICAL EXPLANATION

2-1. FEATURES



■ Ultra Capacity

The Larger drum enables not just higher head drop and stronger centrifugal force, but also less tangling and wrinkling of the laundry. Heavier loads, such as king size comforters, blankets, and curtains, can be washed.



■ Direct Drive System

The advanced Brushless DC motor directly drives the drum without belt and pulley.

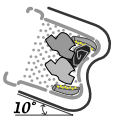

■ Tilted Drum and Extra Large Door Opening

Tilted drum and extra large opening make it possible to load and unload clothing more easily.

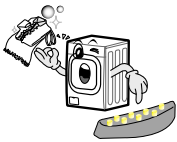

■ RollerJets

Washing ball enhances the wash performance and reduces damage to the clothing. The jets spray and help tumble clothes to enhance washing performance while maintaining fabric care.



■ Automatic Wash Load Detection

Automatically detects the load and optimizes the washing time.



■ Built-in Heater

Internal heater helps to maintain water temperature at its optimum level for selected cycles.



■ Child Lock

The Child lock prevents children from pressing any button to change the settings during operation.

2-2. NEURO FUZZY WASHING TIME OPTIMIZATION

To get the best washing performance, optimal time is determined by the water temperature, the selected washing temperature, and the size of the load.

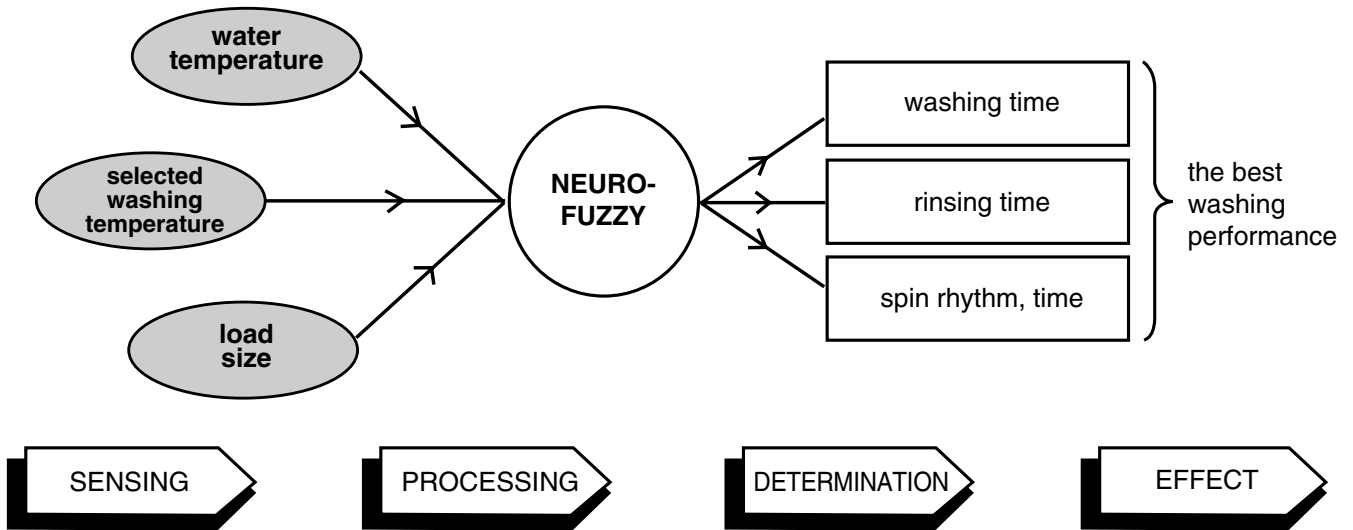

2-3. WATER LEVEL CONTROL

- This model incorporates a pressure sensor which can sense the water level in the tub.
- The water supply is stopped when the water level reaches the preset level, the washing program then proceeds.
- Spinning does not proceed until the water in the tub drains to a certain level.

2-4. DOOR CONTROL

- The door can be opened by pulling the door handle whenever washer is not in operation.
- When the cycle is completed, the DOOR LOCKED light will turn off.
- If a power failure has occurred while in operation, the door will unlock after 5 minutes.
- Clicking sounds can be heard when the door is locked/unlocked.

2-5. THE DOOR CAN NOT BE OPENED

- While program is operating.
- When a power failed and power plug is taken out in operation.
- While Door Lock lights turn on.
- While the motor is in the process of inertial rotating, through the operation is paused.

2-6. DOOR LOCKED LAMP LIGHTS

- When the frequency of water level is lower than 22.9 kHz.
(It can be canceled when the frequency is more than 23.8 kHz.)
- When the temperature inside the tub is higher than 45°C and water level is not 25.5 kHz.
(It can be canceled when the water level is 25.5 kHz or the temperature inside the tub is lower than 40°C.)

2-7. CHILD LOCK

- Use this option to prevent unwanted use of the washer. Press and hold PRE WASH button for 3 seconds to lock/unlock control.
- When child lock is set, CHILD LOCK lights and all buttons are disabled except the Power  button.
You can lock the controls of the washer while washing.

3. PARTS IDENTIFICATION

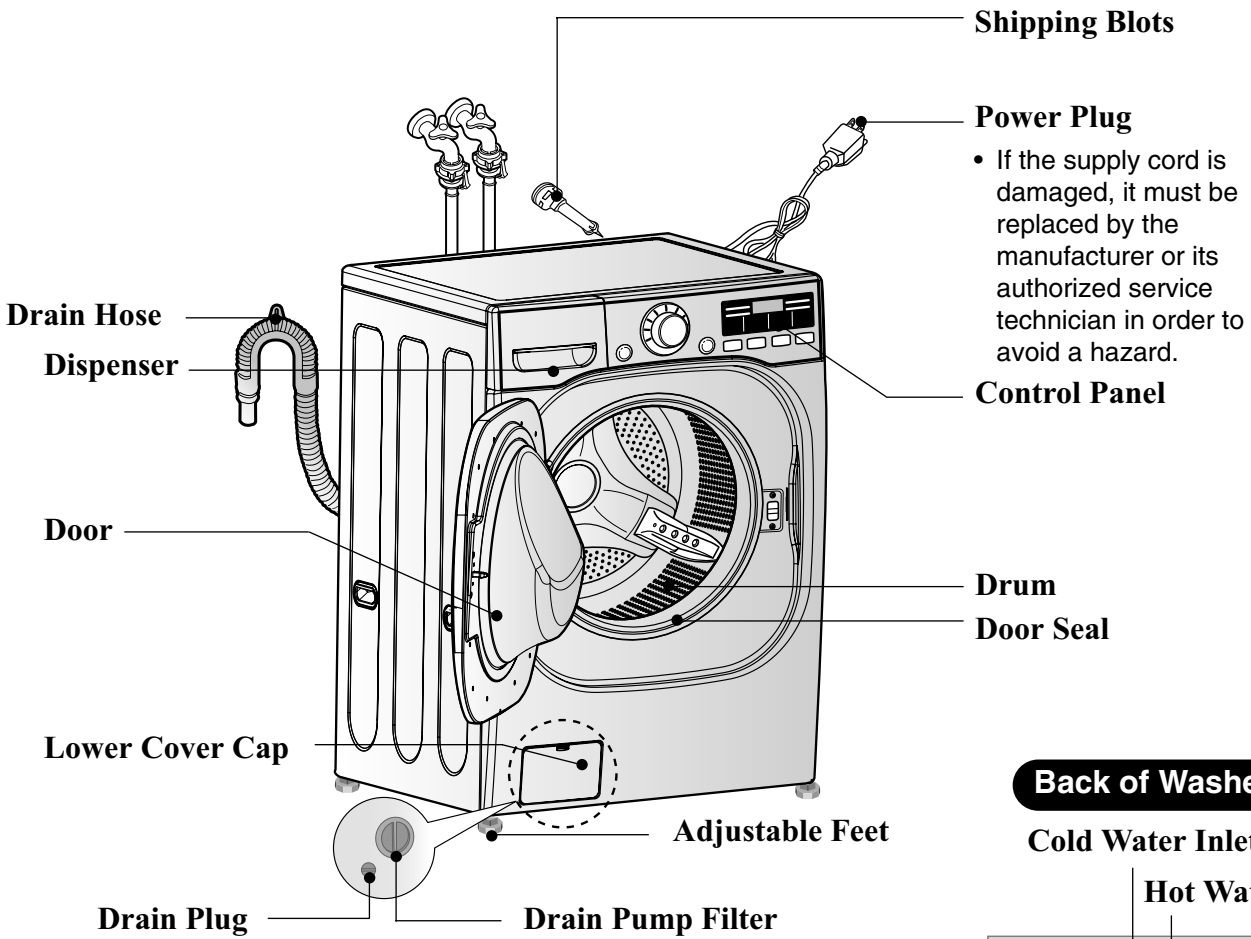

Back of Washer

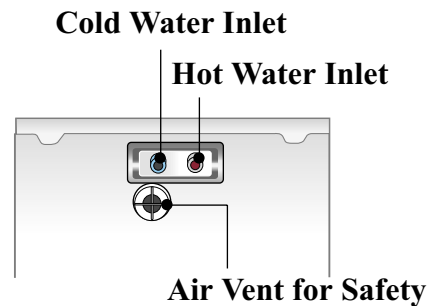

■ ACCESSORIES

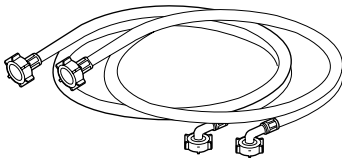

Hot/Cold (1 each)
Hose

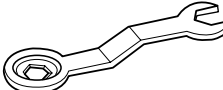

Wrench

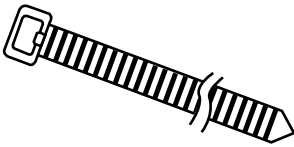

Tie strap (Option)
to secure drain hose to standpipe,
inlet hose, or laundry tub

4. INSTALLATION & TEST

- 1 Before servicing, ask the customer what the trouble is.
- 2 Check the setup (power supply is 120 V AC, remove the transit bolts level the washer...).
- 3 Check with the troubleshooting guide.
- 4 Plan your service method by referring to the disassembly instructions.
- 5 Service the unit.
- 6 After servicing, operate the appliance to see whether it functions correctly.

■ STANDARD INSTALLATION

The appliance should be installed as follows:

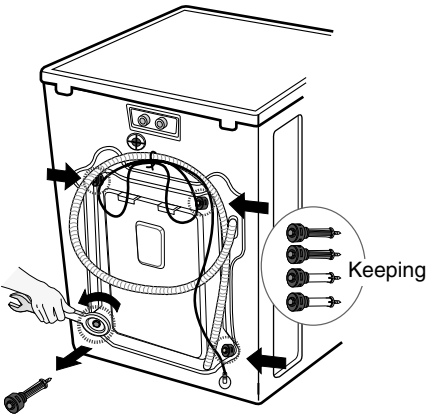
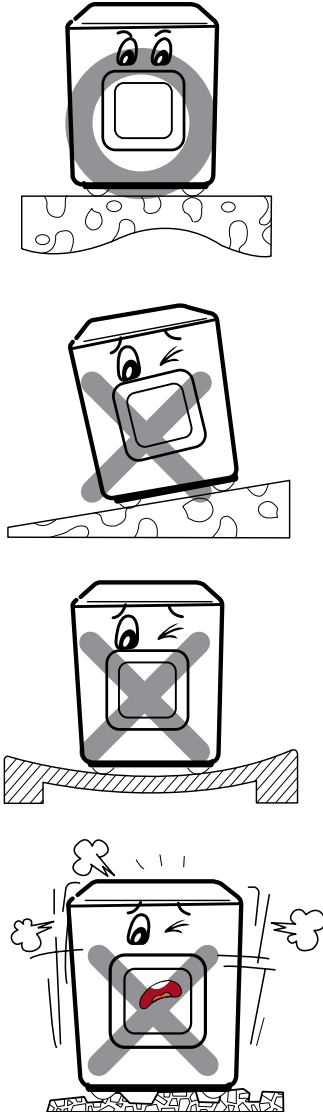
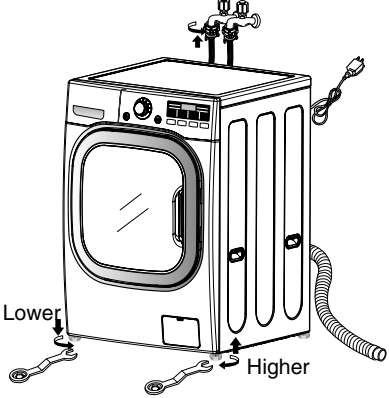
REMOVE THE SHIPPING BOLTS	INSTALL THE APPLIANCE ON A FLAT AND FIRM SURFACE	ADJUST THE LEVELING
<ul style="list-style-type: none"> • Remove the 4 shipping bolts with the supplied wrench. ※ Do first lower side to remove easily. • Keep the shipping bolts and spanner for future use. • Insert the 4 caps (provided) into the hole. 		<ul style="list-style-type: none"> • Turn the leveling feet to adjust the appliance.  <ul style="list-style-type: none"> • Turn clockwise to raise; counterclockwise to lower.

■ HOW TO CONNECT THE INLET HOSE

- Verify that the rubber washer is inside of the valve connector.
- Tighten the inlet hose securely to prevent leaks.
- Install the inlet hose to correct temperature water tap.
Otherwise, it cause **drips on the drawer panel handle and drawer panel.**

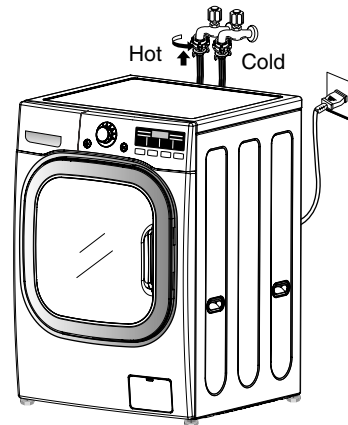

■ CONNECT THE DRAIN HOSE

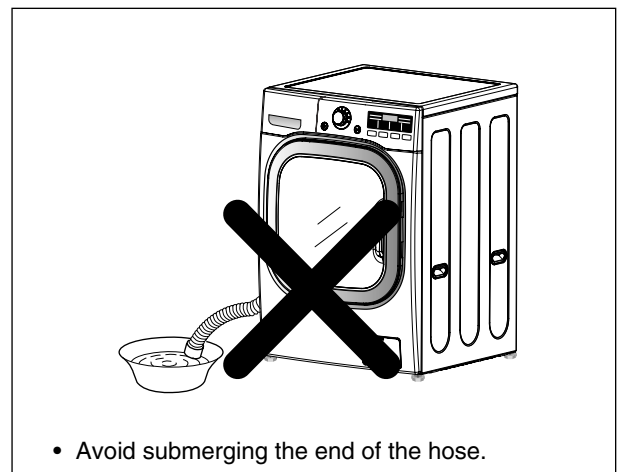
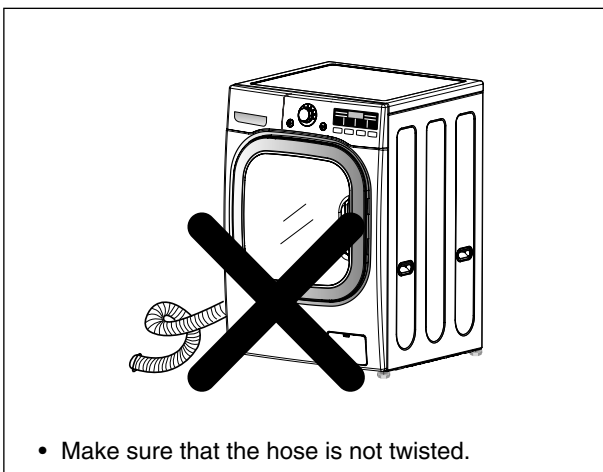

※ The end of the drain hose should be placed less than 96" from the floor.

■ CONNECT POWER PLUG

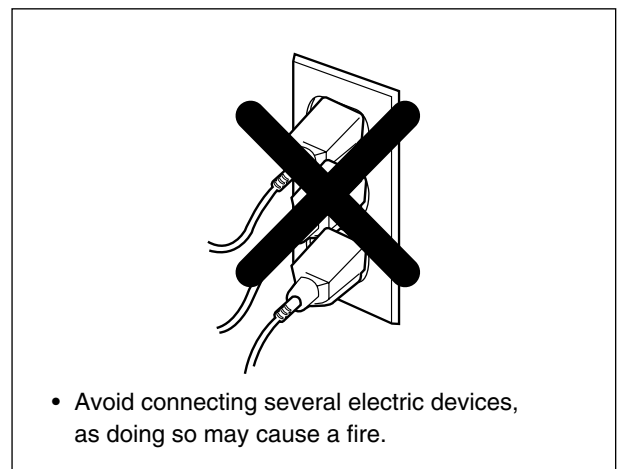
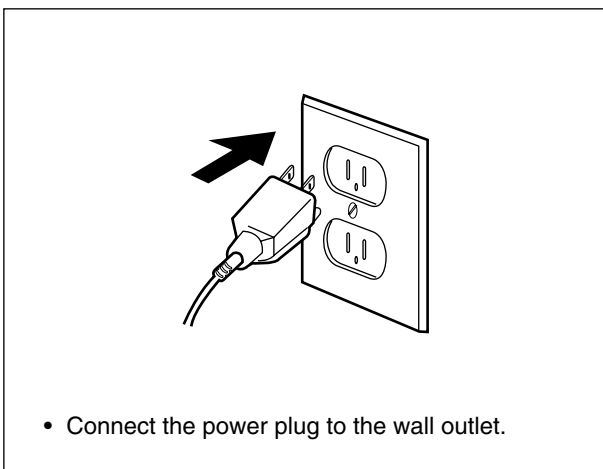

7 TEST OPERATION

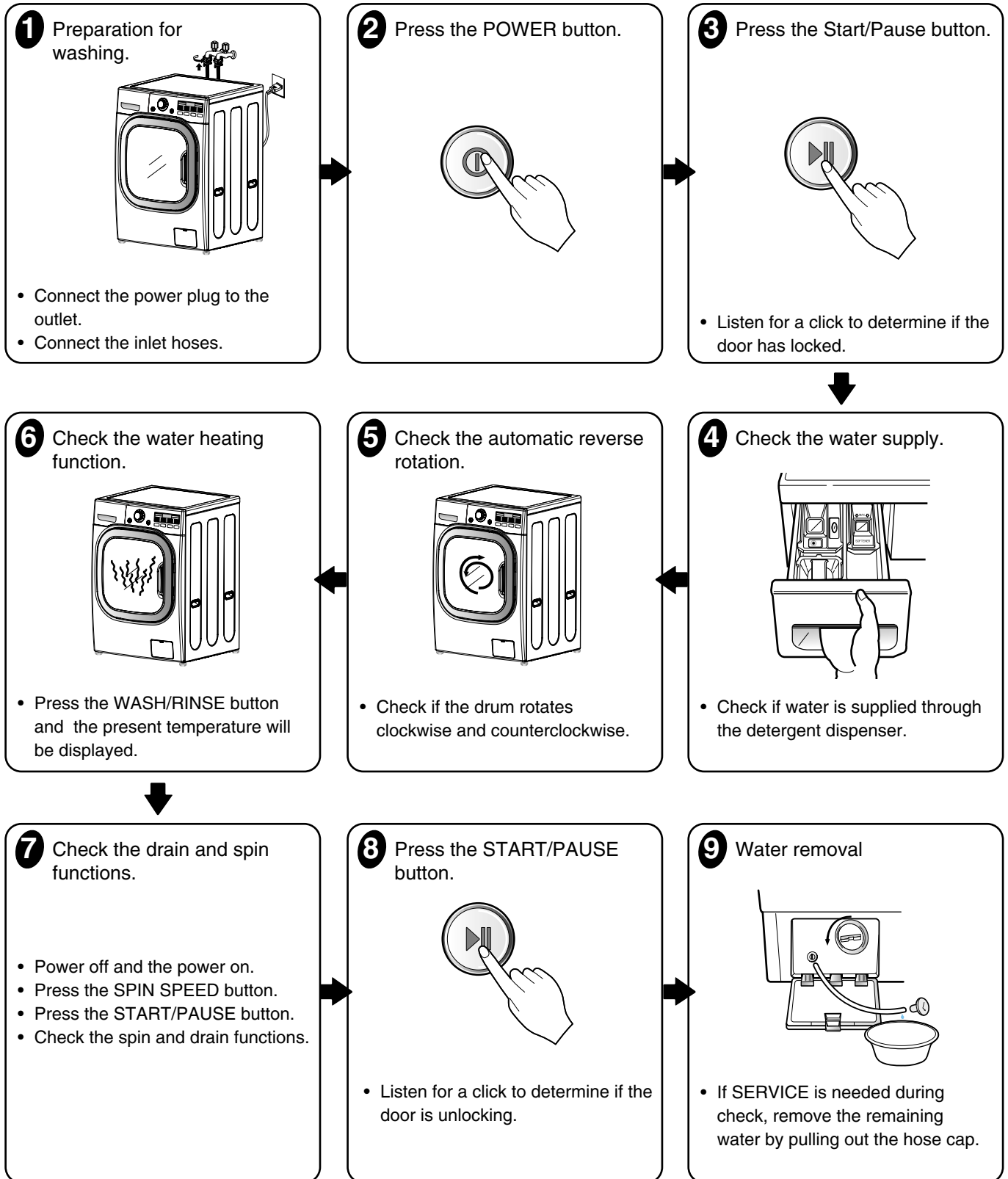

5. OPERATION

5-1. CONTROL PANEL FEATURES

■ WM2601H*

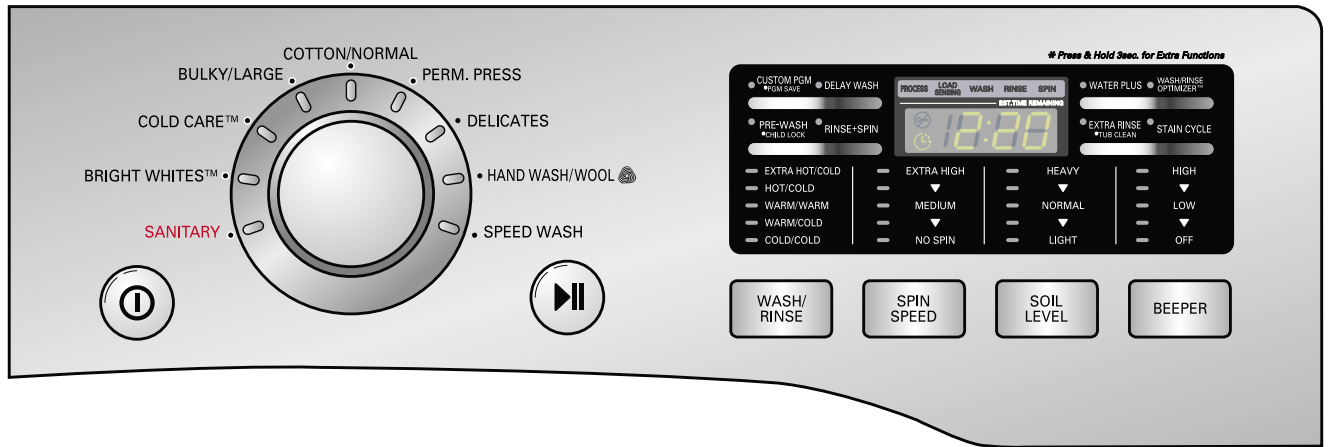

Power Button

- Use this button to turn the power **On/Off**.

Status Indicator

- It shows elapsed time of the cycle the washer is operating.

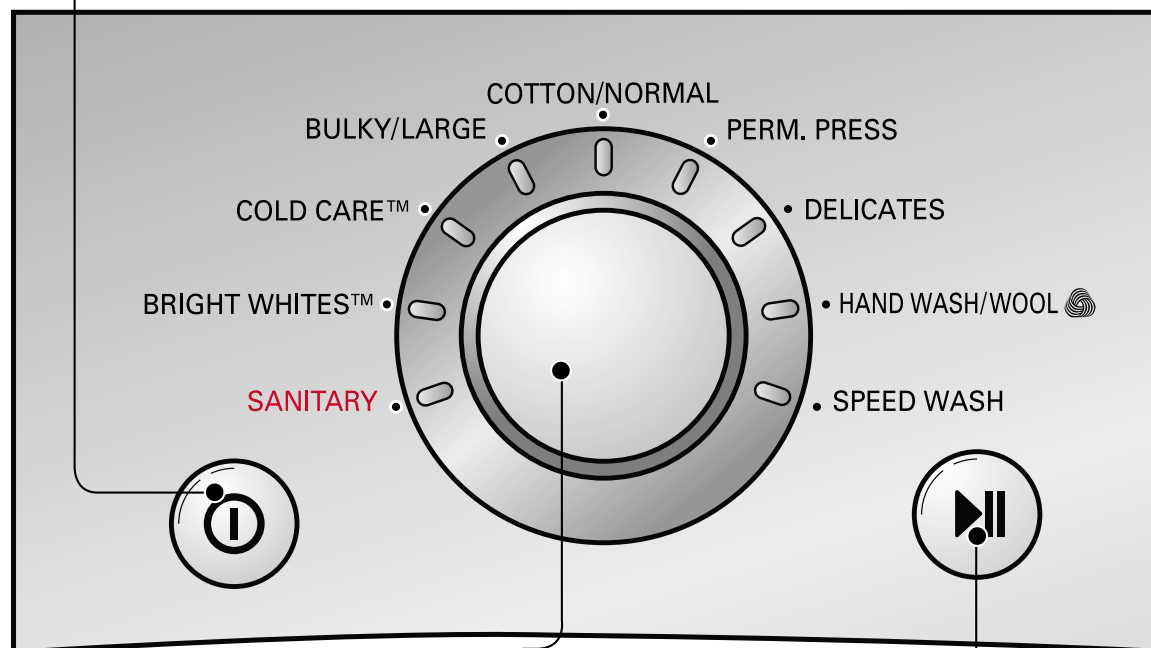

Cycle Selector Knob

- Rotate the **Cycle selector knob** to select the cycle designed for different types of fabric and soil levels.

Start/Pause

- Use this button to **Start/Stop** the washer.

Option Button

Select this option for heavily.

- **WASH/RINSE OPTIMIZER:** Use the WASH/RINSE OPTIMIZER button to select the water level, and detergent mount automatically by the smart sensor & program.
- **PRE WASH:** Use the PREWASH button to select to wash temporary before to start the course which you chosen.
- **CUSTOM PGM:** Use the CUSTOM PGM button to select the course that you has been saved by “PGM SAVE”.
- **DELAY WASH:** Once you have selected the cycle and other settings, press this button to delay the start of the wash cycle.
- **TUB CLEAN:** A buildup of detergent residue can occur in the wash tub over time and can lead to midway or musty smell.
- **RINSE+SPIN:** Select this option to rinse and spin a load separately from a regular cycle.



Wash/Rinse, Spin speed, Soil Level, Beeper Button

- Select a water temperature based on the type of load you are washing.
- To change the spin speed, press the Spin Speed button repeatedly to cycle through available options.
- To change the soil level, press the Soil Level button repeatedly until the desired setting is on.
- Press repeatedly to adjust the volume of the Beeper.

5-2. Cycle Guide

The cycle guide below shows the options and recommended fabric types for each cycle.

Cycle	Fabric Type	Wash/Rinse Temp.	Spin Speed	Soil Level	Pre-Wash	Rinse + Spin	Extra Rinse	Wash/Rinse Optimizer	Water Plus	Stain Cycle
Sanitary	Heavily soiled underwear, work clothes, diapers, etc	Extra Hot/Cold	High	Normal	●	●	●	●	●	●
			Extra High No Spin Low Medium	Heavy Light						
Bright White™	White Fabrics	Warm/Cold	High	Normal	●	●	●	●	●	●
		Cold/Cold Warm/Cold Warm/Warm	Extra High No Spin Low Medium	Heavy Light						
Cold Care™	Small loads of cotton, linen, towels, Shirts, sheets, jeans, mixed loads	Cold/Cold	High	Normal	●	●	●	●	●	●
			Extra High No Spin Low Medium	Light						
Bulky/ Large	Large items such as blankets and comforters	Warm/Cold	Low	Normal	●	●	●	●	●	●
		Warm/Warm Hot/Cold Cold/Cold	Medium No Spin	Heavy Light						
Perm Press	Dress shirts/pants, wrinkle free clothing, poly/cotton blend clothing, table cloths	Warm/Cold	Medium	Normal	●	●	●	●	●	●
		Warm/Warm Hot/Cold Cold/Cold	High No Spin Low	Heavy Light						
Cotton/ Normal	Cotton, linen, towels, shirts, sheets, jeans, mixed loads	Warm/Cold	High	Normal	●	●	●	●	●	●
		Warm/Warm Hot/Cold Cold/Cold	Extra High No Spin Low Medium	Heavy Light						
Delicates	Dress shirts/blouses nylons, sheer or lacy garments	Cold/Cold	Medium	Normal	●	●	●	●	●	●
		Warm/Cold Warm/Warm	No Spin Low	Heavy Light						
Hand Wash/ Wool 	Items labeled "hand washable"	Warm/Cold	Low	Normal	●	●	●	●	●	●
		Warm/Warm Cold/Cold	No Spin	Light						
Speed Wash	Lightly soiled clothing and small loads	Hot/Cold	Extra High	Light	●	●	●	●	●	●
		Cold/Cold Warm/Cold Warm/Warm	No Spin Low Medium High	Normal Heavy						

NOTE: To protect your garments, not every wash/rinse temperature, spin speed, soil level, or option is available with every cycle.

5-3. SPECIAL FUNCTIONS

The option buttons also activate special functions, including CHILD LOCK and TUB CLEAN. Press and hold the option button marked with the special function for 3 seconds to activate.

CHILD LOCK



Use this option to prevent unwanted use of the washer or to keep cycle settings from being changed while the washer is operating. Press and hold the PREWASH button for 3 seconds to activate or deactivate CHILD LOCK. CHILD LOCK will be shown in the display, and all controls are disabled except the ON/OFF button. The washer can be locked during a cycle.

TUB CLEAN

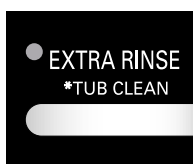

A buildup of detergent residue can occur in the wash tub over time and can lead to a mildew or musty smell. The TUB CLEAN cycle is specially designed to remove this buildup. Press and hold the EXTRA RINSE button for 3 seconds to activate this cycle. The display will show a message to add liquid bleach to the dispenser. After the cycle has ended, open the door and allow the drum interior to dry completely. **NOTE:** Do NOT use this cycle with clothes, and do NOT add detergent or fabric softener.

5-4. Explanation of each process

No.	Process	Explanation
1.	Stay	<ul style="list-style-type: none"> • Electrical power is supplied. • Washer is ready to work and the micom is in the active mode.
2.	Water supply	<ul style="list-style-type: none"> • After loading laundry and selecting a course and a cycle, water is supplied and drum rotates. • When a user selects Pre-wash course, water is supplied through pre wash valve.
3.	Soaking & washing laundry	<ul style="list-style-type: none"> • To get laundry wet, drum rotates clockwise and counterclockwise. • If water amount is insufficient at this time, the Inlet valve will supply water again.
4.	Heating & washing	<ul style="list-style-type: none"> • The heater heats the water in drum to the selected water temperature and drum rotates for washing.
5. ~ 6.	Washing & heating / washing	<ul style="list-style-type: none"> • When the water temperature reaches to the selected temperature, the heating stops and only the drum rotates. • If water temperature becomes lower than selected because of re-supplied water, the heating starts again.
7.	Washing	<ul style="list-style-type: none"> • Fuzzy Logic decides washing time according to the laundry load, water temperature, and other factors.
8.	Drainage	<ul style="list-style-type: none"> • A pump motor drains the water from the drum. • After sensing drained water amount by water level frequency, spin starts. • When a heating course is selected, stay cooling process is performed to decrease the water temperature gradually to prevent laundry from being damaged and for safety reasons.
9.	Untangling (Sensing eccentricity)	<ul style="list-style-type: none"> • It balances laundry load and senses the eccentricity of the load, to only allow spinning without vibration. • If the eccentricity is worse than the allowed level, it repeats the disentangling process. When the repeated time is more than allowed level, it displays UE. • If the eccentricity is good, the intermittent spin starts. • During this process, the drain pump works for drainage intermittently.

No.	Process	Explanation
A.	Intermittent spin	<ul style="list-style-type: none"> To reach the correct set speed, the motor rotates clockwise and counterclockwise directions after spin process starts. If the water level frequency is lower than 23.0 kHz, a washer senses suds and starts suds removal process.
B.	Rinse spin	<ul style="list-style-type: none"> In this process, the remaining water during washing process is extracted and the selected speed is kept. Removing suds process is in active mode at this cycle.
C.	Remaining spin	<ul style="list-style-type: none"> After spin finishes, the drum rotates by remaining spin power until it stops. Motor power is off. This process is overlapped with next process.
D.	Rinse water supply	<ul style="list-style-type: none"> Water supply for rinse process.
E.	Rinse	<ul style="list-style-type: none"> Rinsing process.
F.	Last drainage	<ul style="list-style-type: none"> After spin finishes and power is not supplied to motor, the drum rotates by remaining spin power. If rinse hold is selected, the drainage is not proceeded after rinse finishes.
G.	Disentangling	<ul style="list-style-type: none"> The same as item 9.
H.	Intermittent spin	<ul style="list-style-type: none"> The same as item A.
I.	Main spin1	<ul style="list-style-type: none"> The same as item B.
J.	Main spin2	<ul style="list-style-type: none"> At the end of a main spin, the spin speed will reach the selected rpm.
K.	Remaining spin	<ul style="list-style-type: none"> The same with item C.
L.	Disentangling	<ul style="list-style-type: none"> After spin finishes, disentangling starts to remove unbalanced laundry.
M.	End	<ul style="list-style-type: none"> After 'end' signal is displayed, it stays for 8 seconds and power is automatically turned off. (Auto type door switch) After door switch is off, end signal is displayed in the case of manual type and it takes around 2 minute to turn off door switch.

7. TEST MODE

7-1. SAFETY CAUTION

- There's built-in AC 120V and DC power in output terminal of PWB assembly in common. Be careful electric shock when disconnecting parts while trouble shooting. (Wear Electro Static Discharge gloves when working.)
- After cutting off the power when changing PWB assembly, disconnect or assemble.
- Be careful static when handling PWB assembly, and use Electro Static Discharge plastic pack when delivering or keeping it.

7-2. LOAD TEST MODE

The washer must be empty and the controls must be in the off state.

1. Press the SPIN SPEED and SOIL LEVEL buttons simultaneously.
2. Press the Power (⏻) button, while the above condition. Then buzzer will sound twice.
3. Press the Start/Pause (⏸) button repeatedly to cycle through the test modes.

Number of times the Start/Pause button is pressed	Check Point	Display Status
None	Turns on all lamps and locks the door.	LOAD TEST MODE
1 time	Tumble clockwise.	rpm (42~50)
2 times	Low speed Spin.	rpm (35~45)
3 times	High speed Spin. ※ It will be take about 2minits to be high speed spin	rpm (110~117)
4 times	Inlet valve for prewash turns on.	Water level frequency (0~255)
5 times	Inlet valve for main wash turns on.	Water level frequency (0~255)
6 times	Inlet valve for hot water turns on.	Water level frequency (0~255)
7 times	Inlet valve for bleach turns on.	Water level frequency (0~255)
8 times	Tumble counterclockwise.	rpm (42~50)
9 times	Heater turns on for 3 seconds.	Water temperature
10 times	Drain pump turns on.	Water level frequency (25~65)
11 times	Vibration sensor check.	- None error (bs0) - Main vibration error (bs1)
12 times	off	-

7-3. HOW TO CHECK THE WATER LEVEL FREQUENCY

- * Press the WASH/RINSE and DELAY WASH button simultaneously.

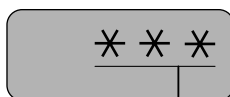

● The digits indicate the water level frequency (x.1 kHz).

So, for example a display indicating 241: a Water level frequency of 241 x.1 kHz
= 24.1 kHz

8. TROUBLESHOOTING

8-1. SAFETY CAUTION

- There's built-in AC 120V and DC power in output terminal of PWB assembly in common. Be careful electric shock when disconnecting parts while trouble shooting. (Wear Electro Static Discharge gloves when working.)
- After cutting off the power when changing PWB assembly, disconnect or assemble.
- Be careful static when handling PWB assembly, and use Electro Static Discharge plastic pack when delivering or keeping it.

8-2. ERROR MODE SUMMARY

- If you press the START/PAUSE button when an error is displayed, any error except **PE** will disappear and the machine will go into the pause status.
- In case of **PE**, **LE**, **DE** if the error is not resolved within 20 seconds, or the in case of other errors, if the error is not resolved within 4 minutes, power will be turned off automatically and the error code will blink. But in the case of **FE** power will not be turned off.

	ERROR	SYMPTOM	CAUSE
1	WATER INLET ERROR	IE	<ul style="list-style-type: none"> • Correct water level (24.6kHz) is not reached within 8 minutes after water is supplied or it does not reach the preset water level within 20 minutes.
2	UNBALANCE ERROR	UE	<ul style="list-style-type: none"> • The load is too small. • The appliance is tilted. • Laundry is gathered to one side. • Non distributable things are put into the drum.
3	DRAIN ERROR	DE	<ul style="list-style-type: none"> • Not fully drained within 10 minutes.
4	OVERFLOW ERROR	FE	<ul style="list-style-type: none"> • Water is overflowing. (water level frequency is over 21.3kHz). ※ If FE is displayed, the drain pump will operate to drain the water automatically.
5	PRESSURE SENSOR ERROR	PE	<ul style="list-style-type: none"> • The PRESSURE SENSOR ASSEMBLY is out of order. • When water level frequency maintain condition of below 10 kHz and over 30 kHz.
6	DOOR OPEN ERROR	DE	<ul style="list-style-type: none"> • Door not all the way closed. • Loose electrical connections at Door switch and PWB Assembly. • The DOOR SWITCH ASSEMBLY is out of order.
7	HEATING ERROR	LE	<ul style="list-style-type: none"> • The THERMISTOR is out of order.

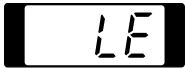
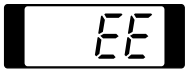
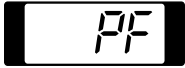
	ERROR	SYMPTOM	CAUSE
8	LOCKED MOTOR ERROR		<ul style="list-style-type: none"> • The connector (3-pin, male, white) in the MOTOR HARNESS is not connected to the connector (3-pin, female, white) of STATOR ASSEMBLY. • The electric contact between the connectors (3-pin, male, white) in the MOTOR HARNESS and 4-pin, female, white connector in the MAIN PWB ASSEMBLY is bad or unstable. • The MOTOR HARNESS between the STATOR ASSEMBLY and MAIN PWB ASSEMBLY is cut (open circuited). • The hall sensor is out of order/defective.
9	EEPROM ERROR		<ul style="list-style-type: none"> • EEPROM is out of order. ※ Displayed only when the START/PAUSE button is first pressed in the Load Test Mode.
10	POWER FAILURE		<ul style="list-style-type: none"> • After the power supply is stopped while washing machine is working, the power is supplied rapidly.

8-3. TROUBLESHOOTING SUMMARY

※ Reference
 Part Name *
 The part of this mark is only
 for steam models.

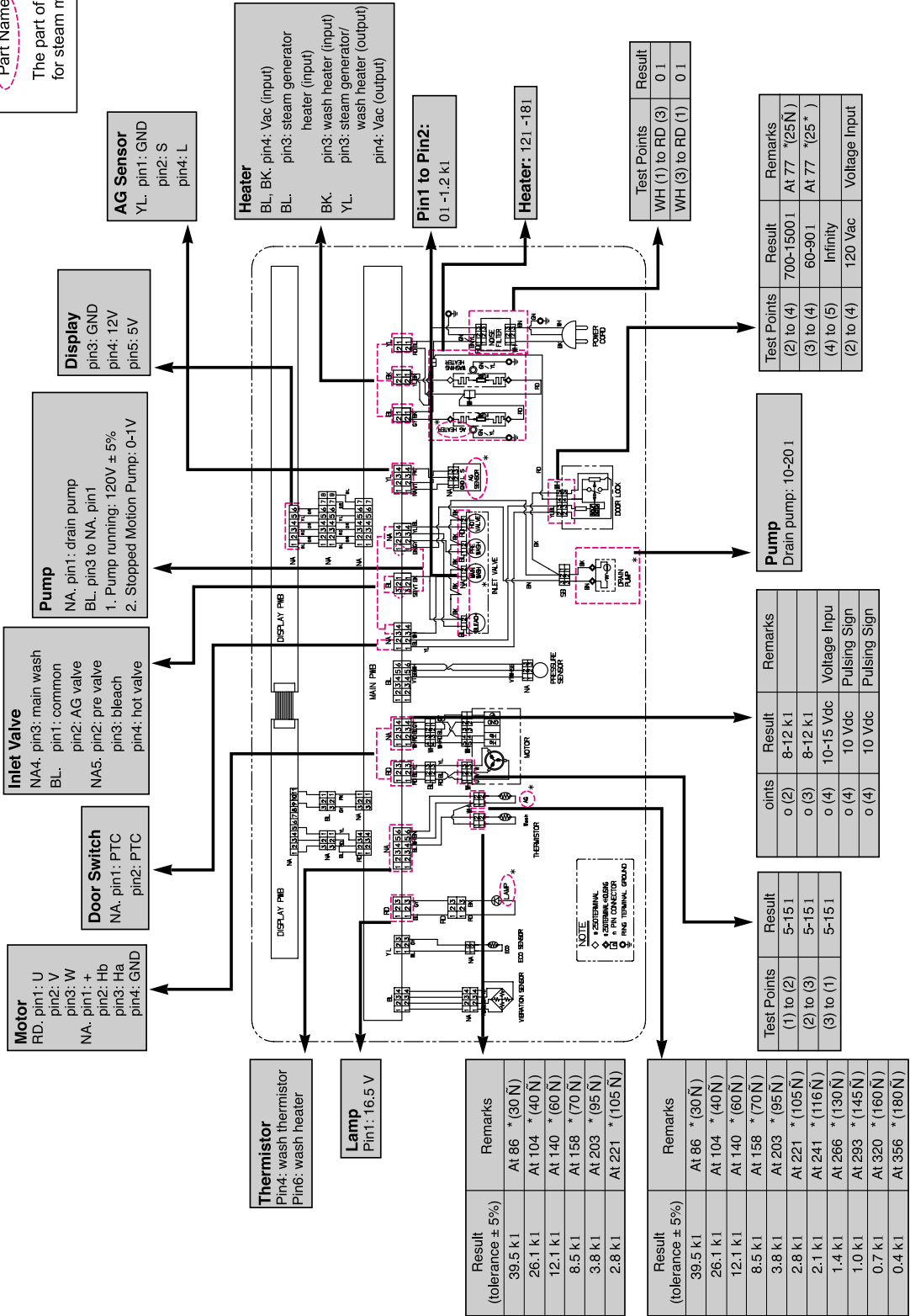

8-4. TROUBLESHOOTING WITH ERROR

INLET VALVE ERROR

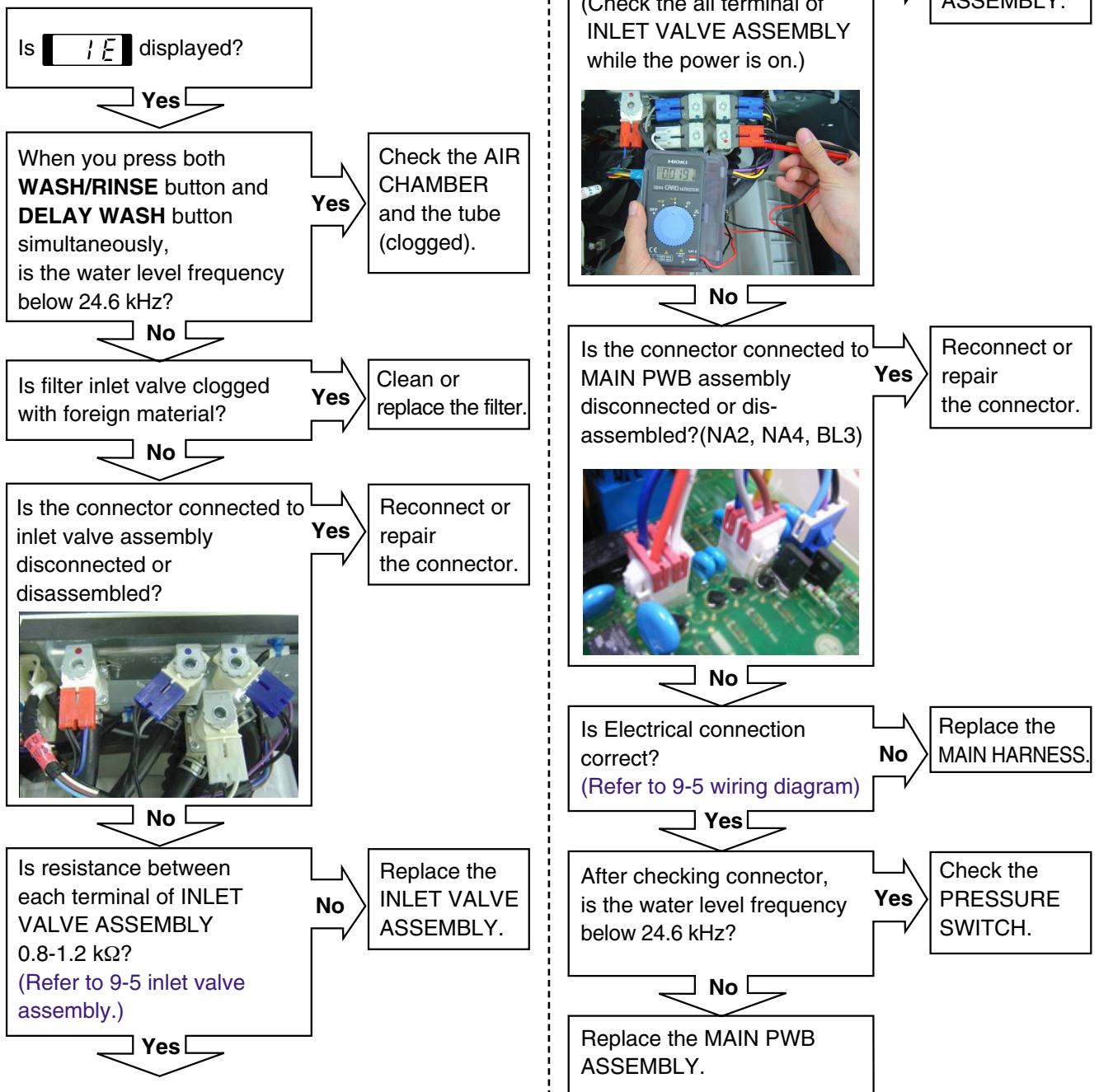

[Note] Environmental safety check list

- 1) No water tap leakage
- 2) No water tap freeze
- 3) No entanglement of water supply hose
- 4) No water shortage
- 5) No shrinkage on water supply hose due to a possible misuse of hot and cold water
- 6) No water supply hose leakage

DRAIN ERROR

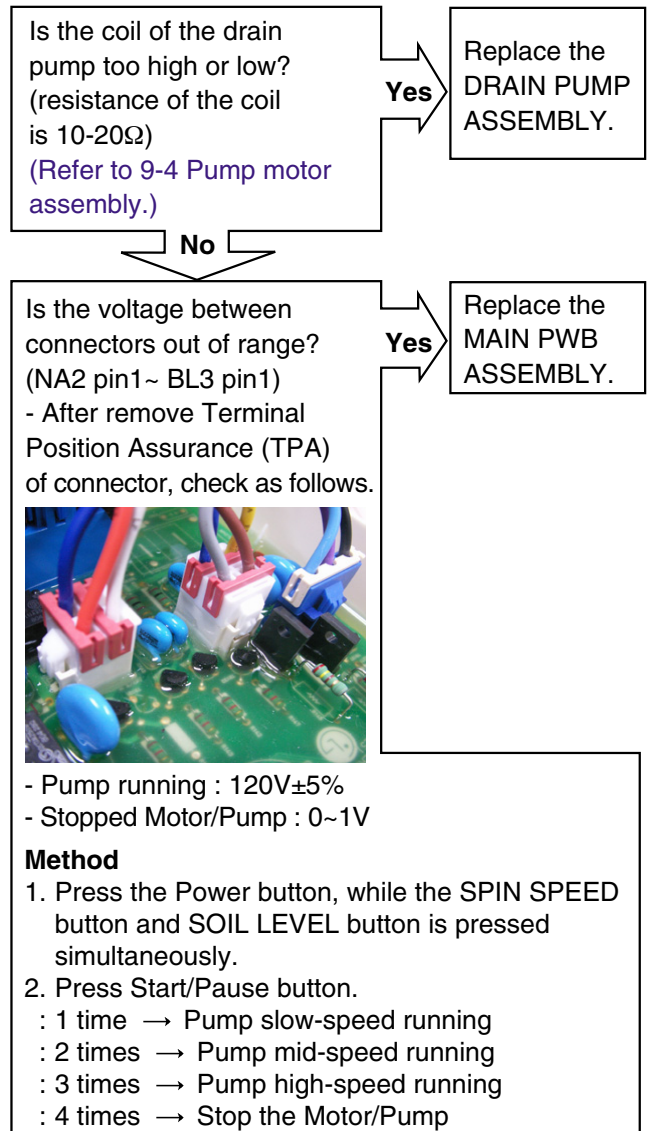
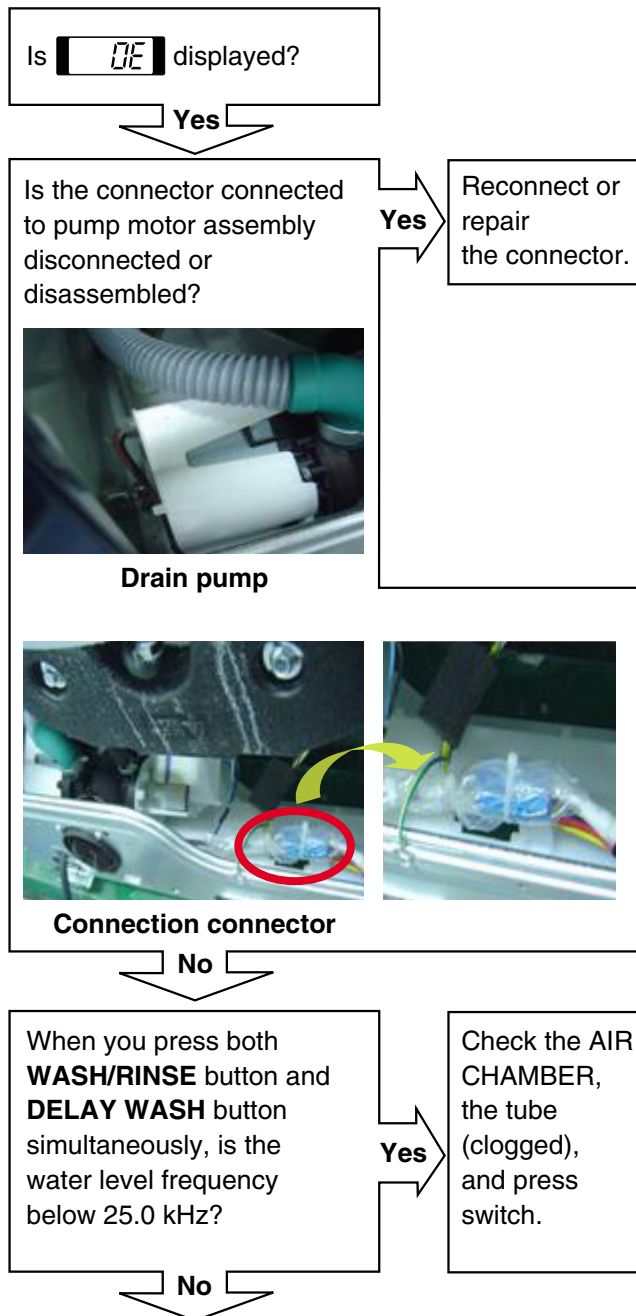

[Note] Environmental check list

- 1) The drainage hose must not stay in a lower position.
- 2) The drainage hose must not be bent or clogged in any way due to the surrounding physical configuration.
- 3) The drainage hose must not get frozen at all times.
- 4) The drainage pump must not have any improper substance or material inside that may cause a machine breakdown.

HEATING ERROR

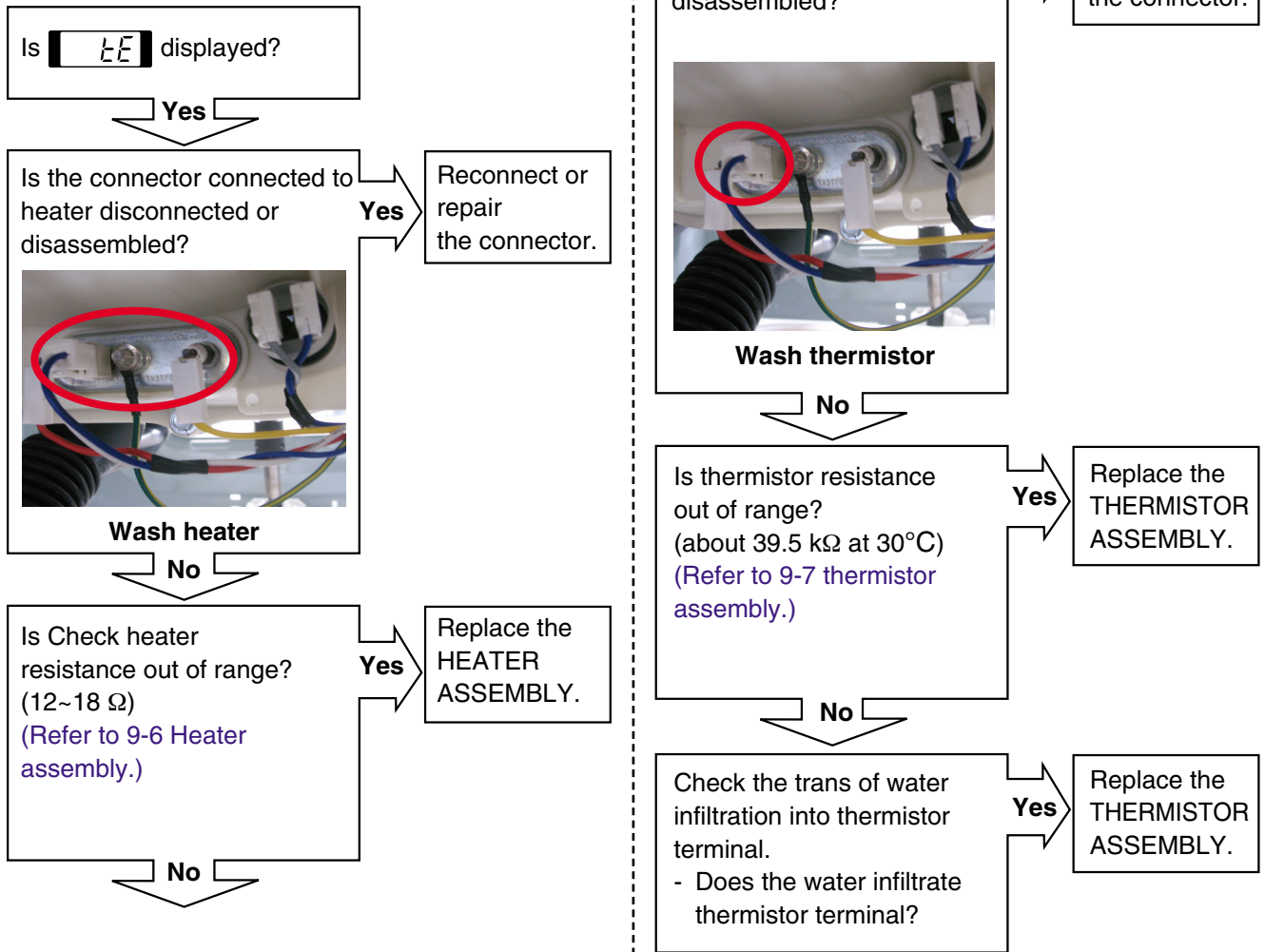

[Note]

Chances that the cause occurs from the main controller are very little.

Sensing part of the circuit (tE) consists of only resistors and capacitors.

LOCKED MOTOR ERROR

Is **LE** displayed?

Yes

Check the connectors below.
Is the connector disconnected or disassembled?
(motor hall sensor connector, motor drive connector.)

- **part of main PWB assembly (NA1, RD4)**

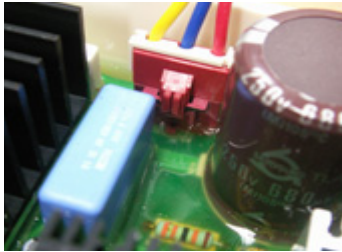

Motor Drive

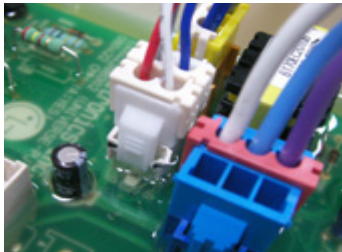

Hall sensor

- **part of wire**



Motor Drive Hall Sensor

Yes

Reconnect the connector.
(connector / wire / motor)

- **part of motor**

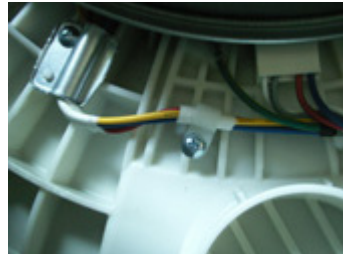

Motor

Yes

Is rotor magnet cracked?

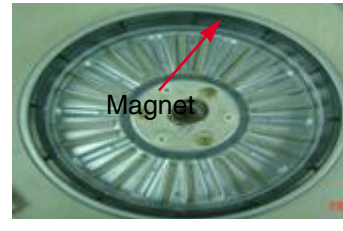

Magnet

Yes

Replace the ROTOR.

No

Is the resistance values in the range of 5 to 15 Ω ?
(U-V, V-W, W-V
:U=1, V=2, W=3)
- After pull out the RD4 connector, check the terminal of the connector in wire. (Red 3P, male)

No

Replace the STATOR.



Yes

Is hall sensor out of order? (Refer to 9-3 Stator assembly/Hall sensor.)

Yes

Replace the Hall sensor.

No

Check the IPM in the controller.

No

Replace the MAIN PWB ASSEMBLY.

DOOR OPEN ERROR

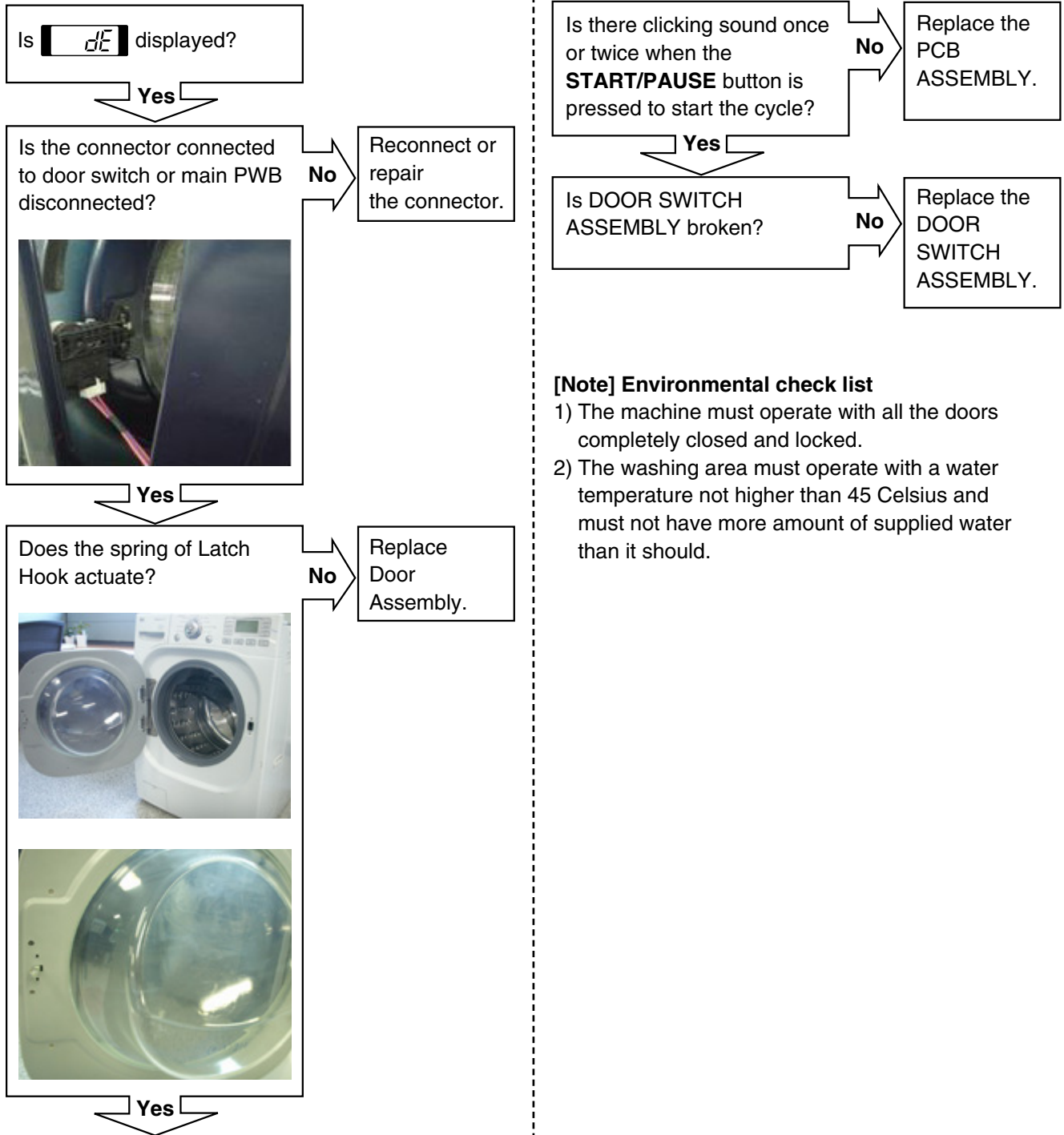

[Note] Environmental check list

- 1) The machine must operate with all the doors completely closed and locked.
- 2) The washing area must operate with a water temperature not higher than 45 Celsius and must not have more amount of supplied water than it should.

UNBALANCE ERROR

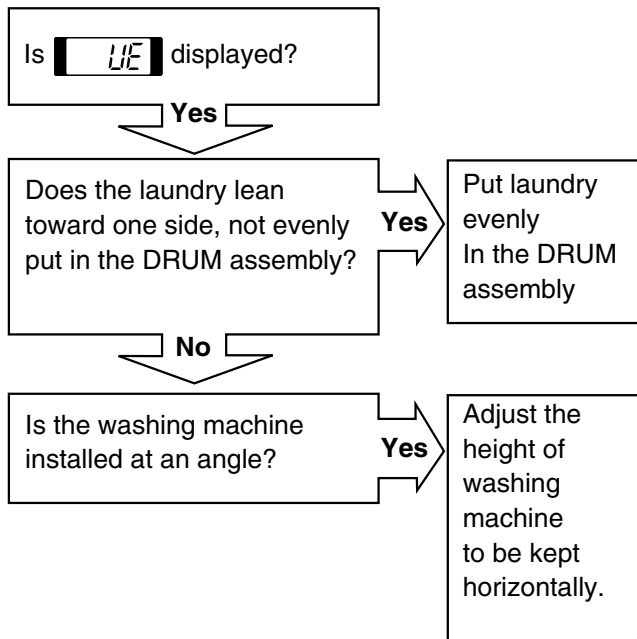

[Note] Environmental check list

- 1) Removal of transportation-based fixed bolt.
- 2) Confirmation on the material to see if it is capable of handling two different types of blanket materials.

OVER FLOW ERROR

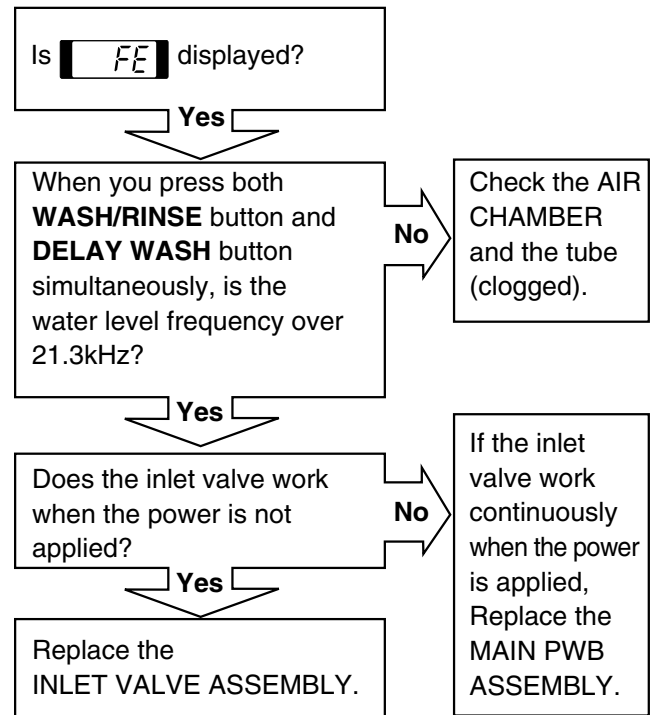

PRESSURE SENSOR ERROR

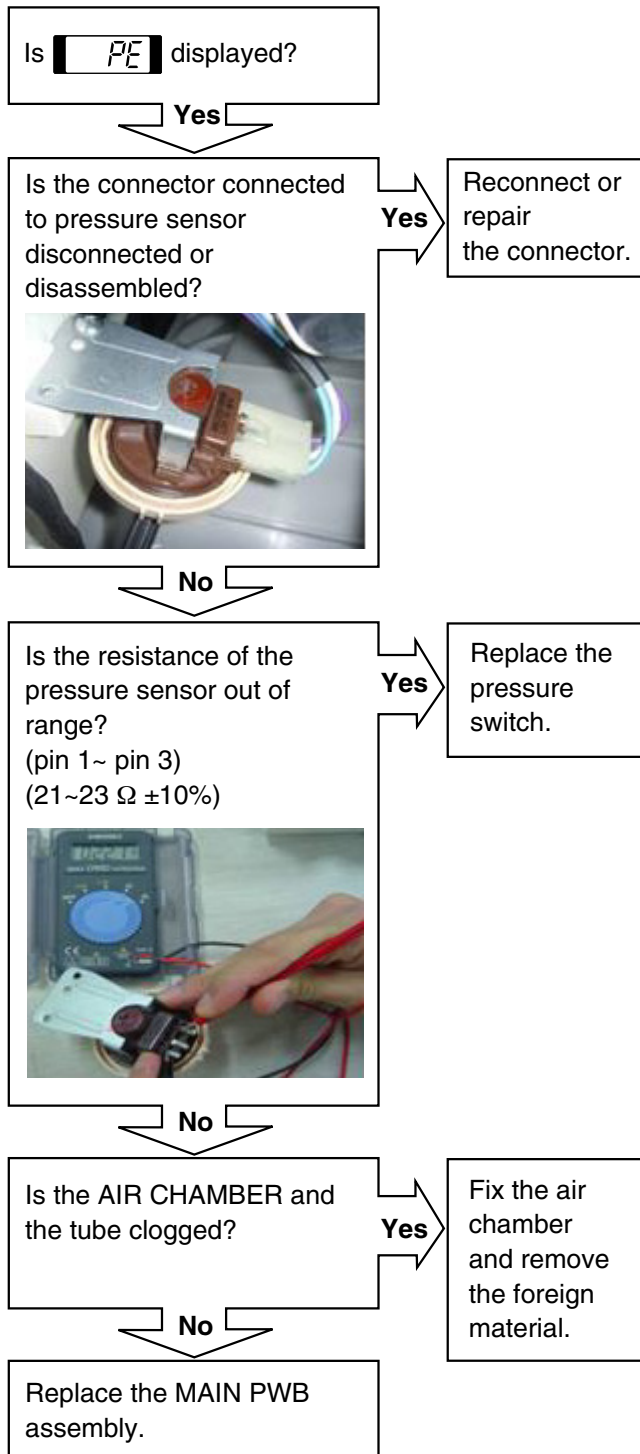

8-5. TROUBLESHOOTING ELSE

⚠ CAUTION

1. Be careful of electric shock if disconnecting parts while troubleshooting.
2. First of all, check the connection of each electrical terminal with the wiring diagram.
3. If you replace the MAIN PWB ASSEMBLY, reinsert the connectors correctly.

NO POWER

Is the supplied voltage 120V AC?(+10%, -15%)

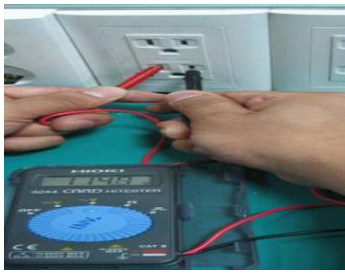

No

Check the fuse or reset the circuit breaker.

Yes

Is the current rating of multi-outlet power strip enough?
(Avoid connecting several electric devices.)



No

Alternate with explanation.

Yes

Is the connector connected to PCB/Noise filter disconnected or disassembled?

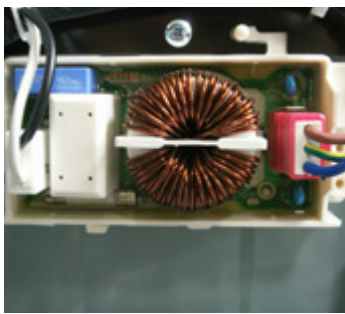

No

Reconnect or repair the connector.

Yes

Is LED on while the power is on?

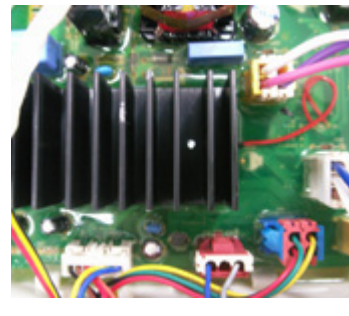

No

Replace the MAIN PWB ASSEMBLY.

Yes

Is five pin wire of display PWB broken?

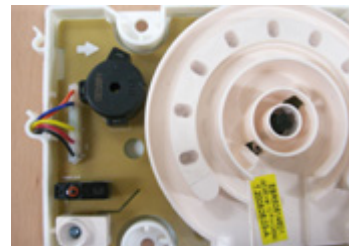

Display PWB

No

Replace the DISPLAY PWB ASSEMBLY.

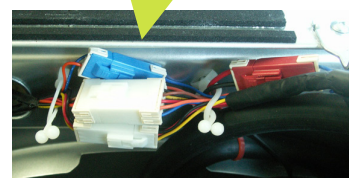

Connecting connector
MAIN PWB~ Display PWB

BUTTON DOESN'T WORK

Is the connector connected to Main PWB / Display PWB disconnected or disassembled?

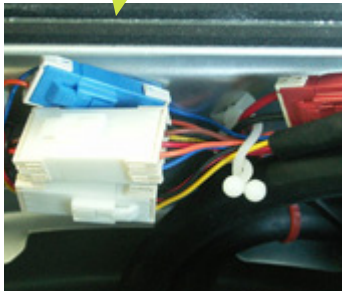
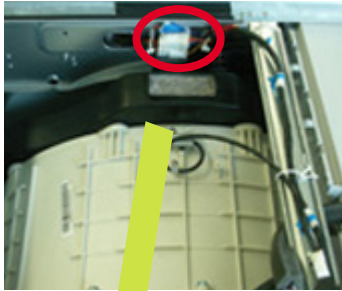

Yes

Reconnect or Repair the connector.

No

Is the button of panel stuck?



Yes

Repair the button.



No

Is the display PCB broken? (check the buzzer sound and LED light while push the button.)



Yes

Replace the DISPLAY PWB ASSEMBLY.

VIBRATION & NOISE IN SPIN

Have all the transit bolts and base packing been removed?

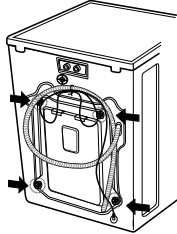

Base Packing

Yes

No

Remove the transit bolts and Base packing.

Is the washer installed on a solidly constructed floor?

Yes

No

Move the washer or reinforce the floor.

Check if the washer is perfectly level as follows:

Check the leveling of the washer with a level and check that the washer is stable.

Level

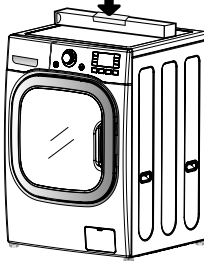

Put an unbalance part (rubber) inside of drum and start QC test mode and run in high spin.

(Refer to section 7-2.)

When the machine is spinning in high speed, verify that it is stable.

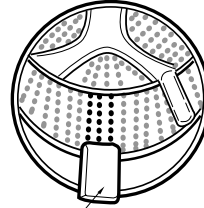

Unbalance Part

If you do not have the unbalance part, put 4.5 to 6.5 lbs (2 to 3 kg) of clothing. Once loaded, press power, Rinse+Spin and the start/pause button in sequence.

When the machine is spinning in high speed, verify that it is stable.

Yes

If it is not stable, adjust feet accordingly. After the washer is level, tighten the lock nuts up against of the base of the washer. All lock nuts must be tightened.

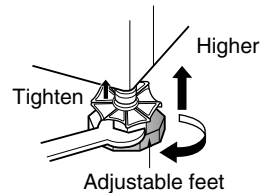

Higher

Tighten

Adjustable feet

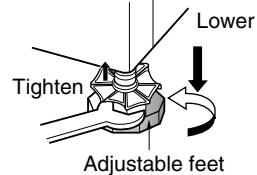

Lower

Tighten

Adjustable feet

Yes

Check the vibration Sensor.

VIBRATION SENSOR CHECK

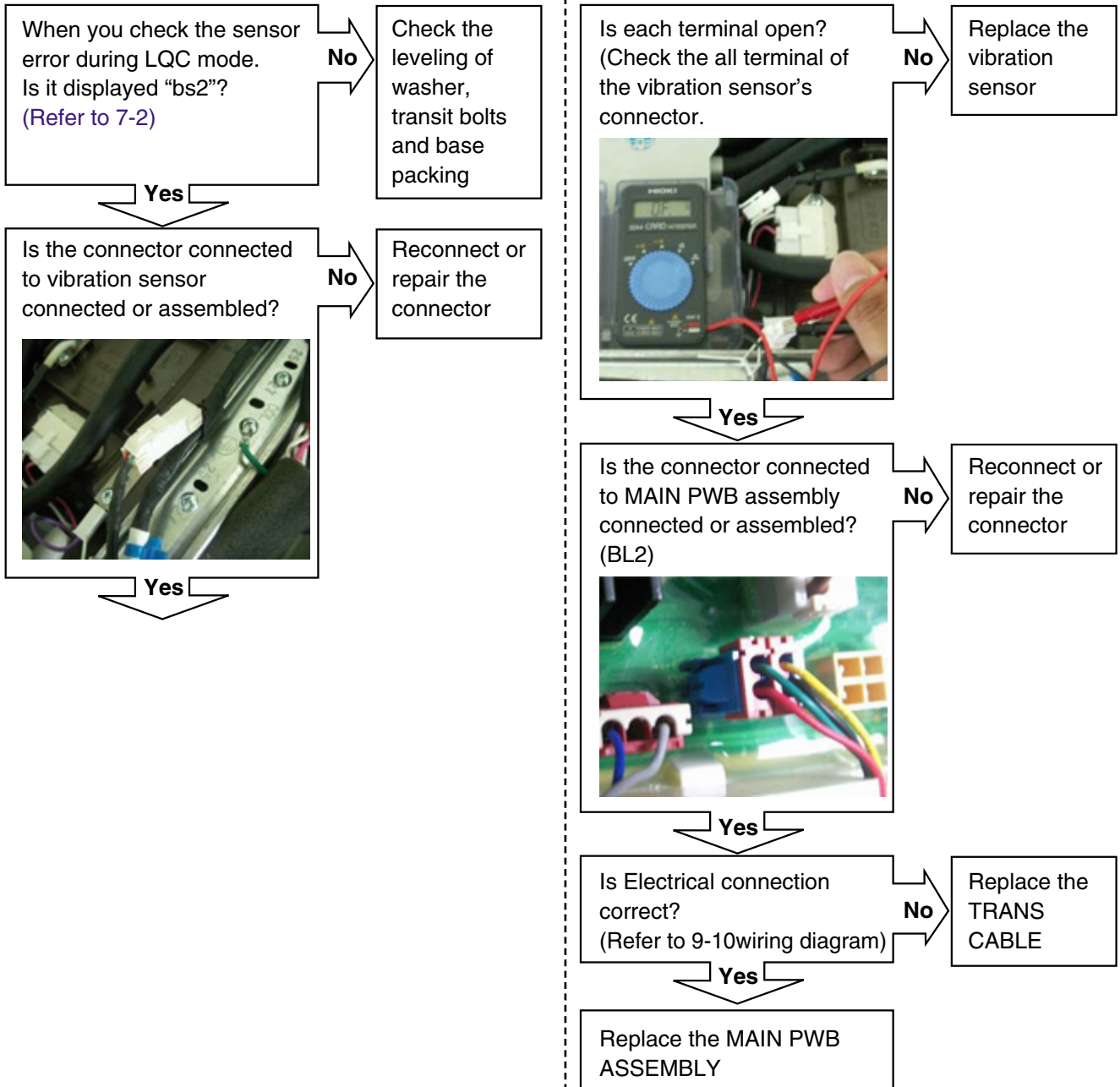

[Note]

Chances that the cause occurs from the main controller are very little. Sensing part of the circuit consists of only resistors and capacitors.

DETERGENT DOES NOT FLOW IN

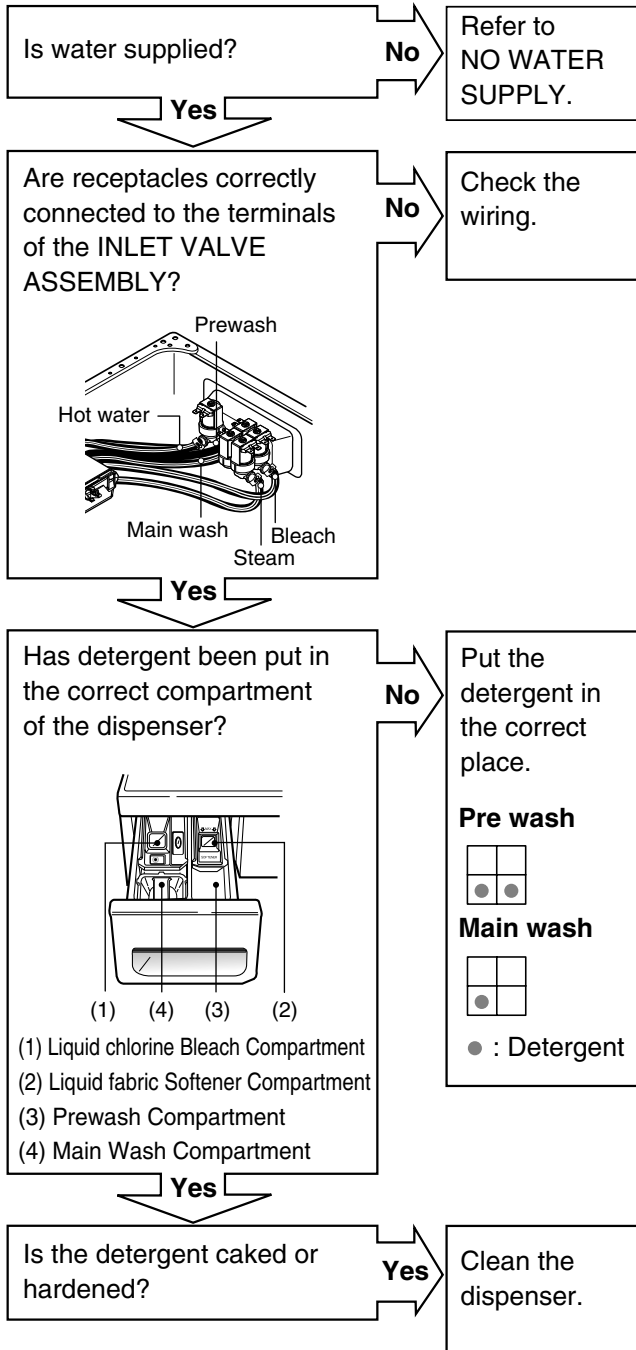

LIQUID DETERGENT/SOFTENER/ BLEACH DOES NOT FLOW IN

Is water supplied? **No** Refer to NO WATER SUPPLY.

Are the plugs correctly connected to the terminals of the INLET VALVE ASSEMBLY? **No** Check the wiring on the dispenser.

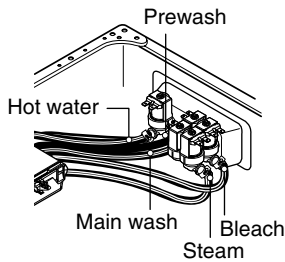

Is liquid detergent/softener/bleach put in the correct compartment of the drawer? **No** Put it in the correct compartment.

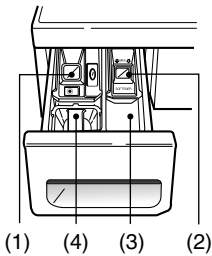

- (1) Liquid chlorine Bleach Compartment
- (2) Liquid fabric Softener Compartment
- (3) Prewash Compartment
- (4) Main Wash Compartment

Is the liquid detergent/softener/bleach cap clogged? **Yes** Clean the cap and container.

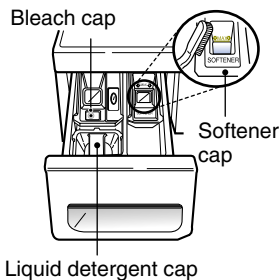

ABNORMAL SOUND

Is the motor bolt loosened? **Yes** Secure the bolt.

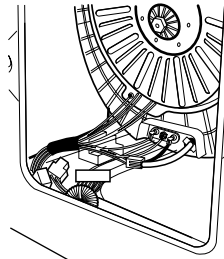

Is there friction noise coming from the motor? **Yes** Check hall sensor. Replace if defective. Then check stator. Replace if necessary. Check rotor for broken magnets. Replace rotor if necessary.

9. COMPONENT TESTING INFORMATION

⚠ WARNING When Resistance (Ohm) checking the Component, be sure to turn the power off, and do voltage discharge sufficiently.

9-1. FILTER ASSEMBLY (LINE FILTER)

<p>Wiring diagram</p>	<p style="text-align: center;">Circuit in the MAIN PWB / Wiring Diagram</p>						
<p>Test points and Result</p>	 <table border="1" style="margin-left: auto; margin-right: auto;"> <thead> <tr> <th>Test Points</th> <th>Result</th> </tr> </thead> <tbody> <tr> <td>WH (1) to RD (3)</td> <td>0 Ω</td> </tr> <tr> <td>WH (3) to RD (1)</td> <td>0 Ω</td> </tr> </tbody> </table>	Test Points	Result	WH (1) to RD (3)	0 Ω	WH (3) to RD (1)	0 Ω
Test Points	Result						
WH (1) to RD (3)	0 Ω						
WH (3) to RD (1)	0 Ω						

9-2. DOOR LOCK SWITCH ASSEMBLY

<p>Wiring diagram</p>	<p style="text-align: center;">Circuit in the MAIN PWB / Wiring Diagram</p>
<p>Function</p>	<p>The Door Lock Switch Assembly consists of a Heating PTC, a Bimetal, a Protection PTC, and a Solenoid. It locks the door during a wash cycle.</p> <ol style="list-style-type: none"> 1. Operation for door closing <ul style="list-style-type: none"> - After the system turns on, PTC heating starts up through terminal 2~4's authorizing the power on. - After PTC heating starts up and before solenoid operation is driven, force the system to the off position through CAM. ⇒ Door close - Authorizing one impulse through terminal 3~4 (PTC & solenoid) will make the door locked. - Door lock is detected when switches in terminal 4~5 are set closed. ⇒ CAM rotation will forcibly clear off the connection. <li style="padding-left: 20px;">The maximum, allowable number of impulse authorizations is 2. ⇒ Upon the third authorization of the impulse, the position of CAM goes back to the door-open position. - Authorizing the impulse occurs in 4.5 seconds upon input for max performance and two authorization processes are allowed at most. ⇒ Normal operation period of PTC heating: 1.5 – 5 seconds. (Defects from the development process.) 2. Operation for door opening <ul style="list-style-type: none"> - With a temporary stop, door automatically opens by CAM rotations after authorizing the impulse from the terminal 3 ~ 4 and the power turns off – maximum of 3 times of the authorizing period. - Upon the fourth authorization of the impulse, the position of CAM goes back to the door-close position.

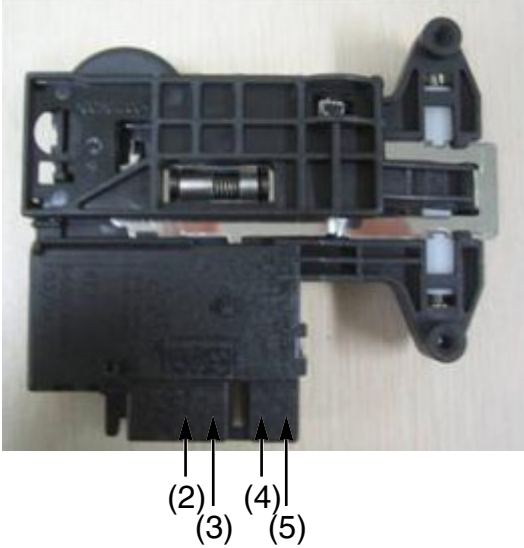
<p>Test points</p>																
<p>Result</p>	<table border="1"> <thead> <tr> <th>Test Points</th> <th>Result</th> <th>Remarks</th> </tr> </thead> <tbody> <tr> <td>(2) to (4)</td> <td>700-1500 Ω</td> <td>At 77°F (25°C)</td> </tr> <tr> <td>(3) to (4)</td> <td>60-90 Ω</td> <td>At 77°F (25°C)</td> </tr> <tr> <td>(4) to (5)</td> <td>Infinity</td> <td></td> </tr> <tr> <td>(2) to (4)</td> <td>120 Vac</td> <td>Voltage Input</td> </tr> </tbody> </table>	Test Points	Result	Remarks	(2) to (4)	700-1500 Ω	At 77°F (25°C)	(3) to (4)	60-90 Ω	At 77°F (25°C)	(4) to (5)	Infinity		(2) to (4)	120 Vac	Voltage Input
Test Points	Result	Remarks														
(2) to (4)	700-1500 Ω	At 77°F (25°C)														
(3) to (4)	60-90 Ω	At 77°F (25°C)														
(4) to (5)	Infinity															
(2) to (4)	120 Vac	Voltage Input														

9-3. STATOR ASSEMBLY

<p>Wiring diagram</p>	<p style="text-align: center;">Circuit in the MAIN PWB / Wiring Diagram</p>								
<p>Function</p>	<p>The DD motor can be driven from stopped to maximum speed in infinite steps in either direction.</p> <p>There are 36 poles on the stator; 12 permanent magnets spaced around the rotor. There are no brushes to wear out. Unlike a more traditional brushless motor, the rotor surrounds the stator rather than being attached to it.</p>								
<p>Test points (Windings)</p>									
<p>Result (Windings)</p>	<table border="1" style="margin-left: auto; margin-right: auto;"> <thead> <tr> <th>Test Points</th> <th>Result</th> </tr> </thead> <tbody> <tr> <td>(1) to (2)</td> <td>5-15 Ω</td> </tr> <tr> <td>(2) to (3)</td> <td>5-15 Ω</td> </tr> <tr> <td>(3) to (1)</td> <td>5-15 Ω</td> </tr> </tbody> </table>	Test Points	Result	(1) to (2)	5-15 Ω	(2) to (3)	5-15 Ω	(3) to (1)	5-15 Ω
Test Points	Result								
(1) to (2)	5-15 Ω								
(2) to (3)	5-15 Ω								
(3) to (1)	5-15 Ω								

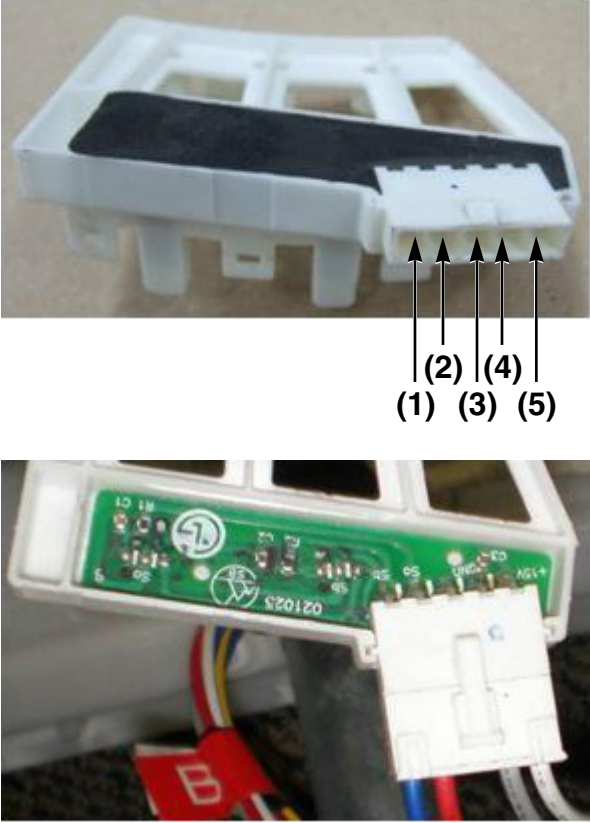
	<p>The hall sensor determines the speed and direction of the motor. It also can read that the load is off balance when the drum speed fluctuates.</p>
<p>Test point and Result (Hall Sensor)</p>	<p>- Voltage Testing Hall Sensor at Stator</p>  <p>If measuring voltage from the Main PCB Assembly to the Hall Sensor, use the following steps:</p> <ol style="list-style-type: none"> 1. Unplug power cord. 2. Remove rear washer panel. 3. Locate Hall sensor connector on the stator behind the rotor. 4. Place meter leads on terminals 5 to 4, white to gray. 5. Plug in power cord, close door, and press power button. DO NOT PRESS START! 6. You should measure 10 to 15 Vdc. If 10 to 15 Vdc is present, control board, white wire, and gray wire are OK! If not follow testing output voltages on control board in next section.

7. To measure output signal voltage from the hall sensor, carefully move test leads to terminals 1 to 4, blue and gray. Slowly rotate motor rotor by hand. You should read a pulsing 10 Vdc. If 10 Vdc is measured from 1 to 4, move lead on blue wire to red wire, terminal 2. Repeat rotating motor rotor by hand. You should read a pulsing 10 Vdc from red to gray.
8. If pulsing 10 Vdc is measured from 1 to 4 and 2 to 4, hall sensor is OK! If either test netted only 9 to 10 Vdc without changing (no pulsing) the hall sensor is likely defective. Disconnect power by unplugging washer and ohm check hall sensor to verify failure of the hall sensor.

**Test Point
and
Result
(Hall
Sensor)**

- Voltage Testing Hall Sensor from the Main PCB Assembly

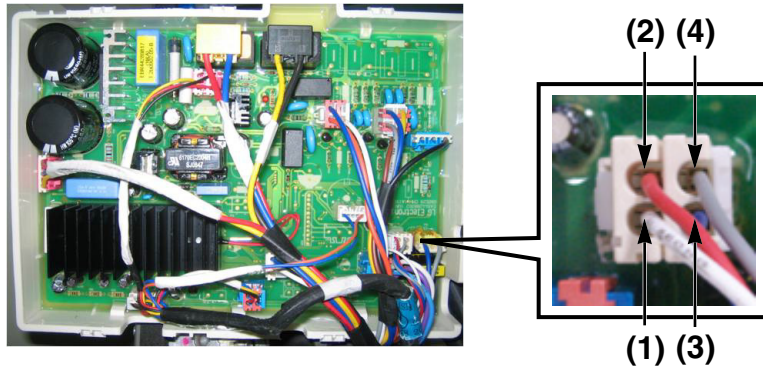

1. Unplug power cord.
2. Remove rear panel.
3. Remove Washer Top.
4. Remove Main PCB Assembly cover as shown in Figure below.
5. Locate the white Hall Sensor 4 wire connector using wiring diagram wire colors as your guide.
6. Plug in power cord, close door, and press power button. **DO NOT PRESS START!**
7. Place meter leads on White & Gray wires. You should read 10 to 15 Vdc output from the Main PCB Assembly to the Hall sensor. If no 10 to 15 Vdc is measured the control board is defective.
8. Place meters leads on Blue to Gray. Turn motor rotor slowly by hand. You should measure a pulsing 10 Vdc. Place meter leads on Red to Gray. Turn motor rotor slowly by hand. You should measure a pulsing 10 Vdc. If both tests measure a pulsing 10 Vdc, hall sensor and harness OK. If either or both tests measures 9 to 10 volts, but does not pulse or change, Hall sensor has failed and must be replaced. IF zero (0) voltage is measured on either test, check red & blue wires for continuity. Repair or replace harness as needed.

Test Points	Result	Remarks
(1) to (2)	8-12 kΩ	
(1) to (3)	8-12 kΩ	
(1) to (4)	10-15 Vdc	Voltage Input
(2) to (4)	10 Vdc	Pulsing Signal
(3) to (4)	10 Vdc	Pulsing Signal

9-4. PUMP MOTOR ASSEMBLY

<p>Wiring diagram</p>	<div style="display: flex; justify-content: space-around;"> <div style="border: 1px solid gray; padding: 5px; width: 45%;"> <p style="text-align: center; background-color: #cccccc;">Circuit in the MAIN PWB</p> <p style="text-align: center;">Pump Driving circuit</p> </div> <div style="border: 1px solid gray; padding: 5px; width: 45%;"> <p style="text-align: center; background-color: #cccccc;">Wiring Diagram</p> <p style="text-align: center;">DRAIN PUMP</p> </div> </div> <p style="text-align: center; margin-top: 10px;">* Each circuits of loads in wiring diagram are all same.</p>				
<p>Object</p>	<p style="text-align: center;">For Drain</p>				
<p>Function</p>	<p>Two pump motors are used to drain the tub and to circulate the water / detergent solution.</p>				
<p>Test points</p>	<p style="text-align: center;">Drain Pump</p> <div style="display: flex; justify-content: space-around;"> </div>				
<p>Result</p>	<p style="text-align: center;">Drain Pump</p> <table border="1" style="margin-left: auto; margin-right: auto;"> <thead> <tr> <th>Test Points</th> <th>Result</th> </tr> </thead> <tbody> <tr> <td>(1) to (2)</td> <td>10-20 Ω</td> </tr> </tbody> </table>	Test Points	Result	(1) to (2)	10-20 Ω
Test Points	Result				
(1) to (2)	10-20 Ω				

9-5. INLET VALVE ASSEMBLY

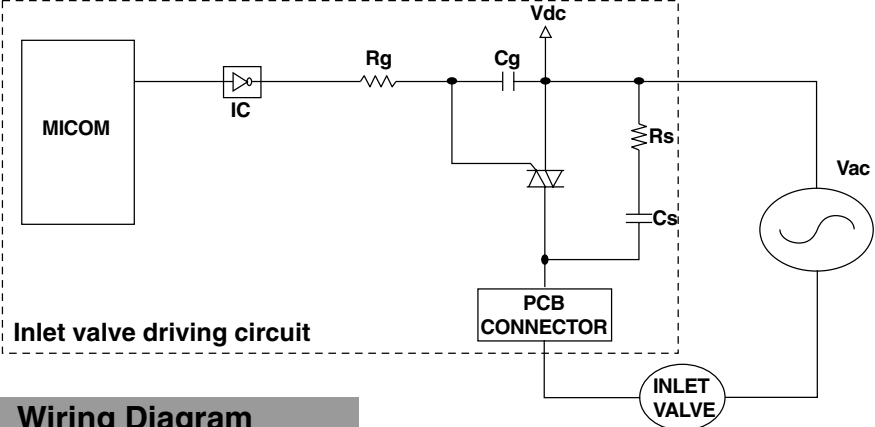
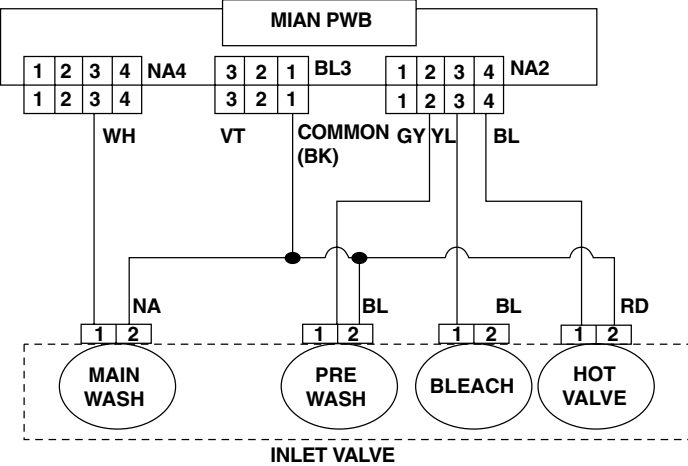
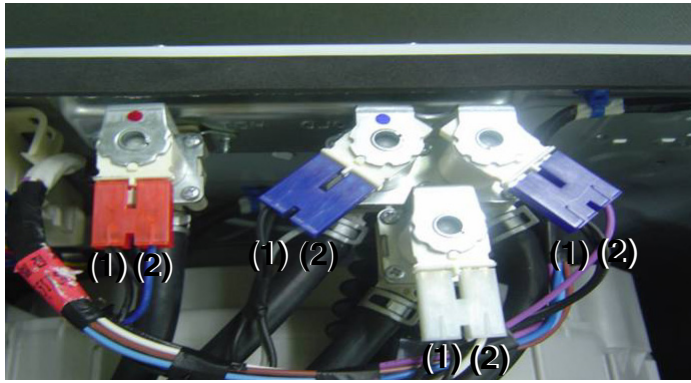
<p>Wiring diagram</p>	<div style="text-align: center; background-color: #cccccc; padding: 5px; margin-bottom: 10px;">Circuit in the MAIN PWB</div>  <div style="text-align: center; background-color: #cccccc; padding: 5px; margin-bottom: 10px;">Wiring Diagram</div>  <p style="text-align: center;">* Each circuits of loads in wiring diagram are all same.</p>				
<p>Function</p>	<p>Depending on the cycle and water temperature, the controller will energize the hot or cold water valve solenoids to meet the selected water temperature.</p>				
<p>Test points and Result</p>	<p>After pull out the connector of defective valve, check the resistance.</p>  <table border="1" style="margin-left: auto; margin-right: auto;"> <tr> <td>Test points</td> <td>(1)-(2)</td> </tr> <tr> <td>Result</td> <td>0.8-1.2 kΩ</td> </tr> </table>	Test points	(1)-(2)	Result	0.8-1.2 kΩ
Test points	(1)-(2)				
Result	0.8-1.2 kΩ				

9-6. HEATER ASSEMBLY

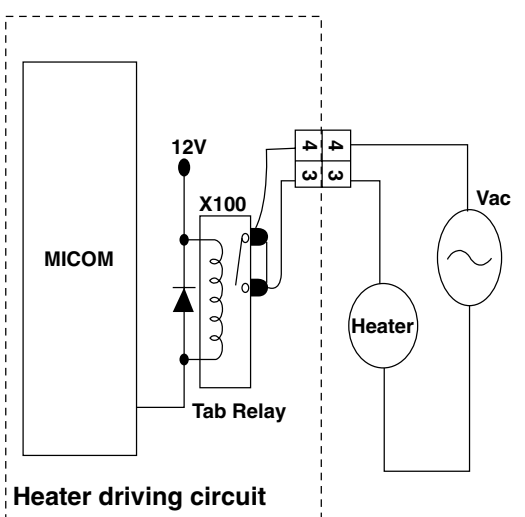
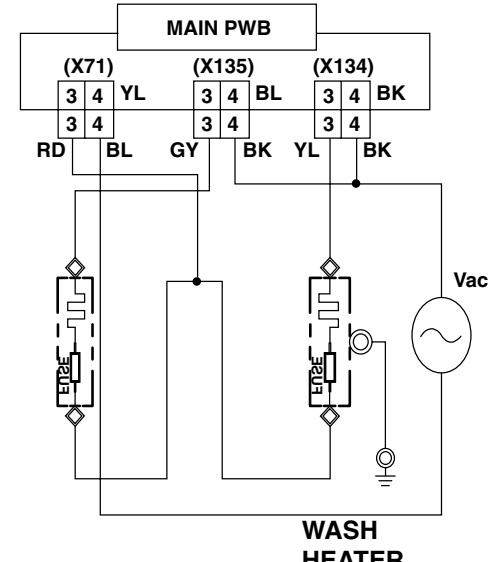
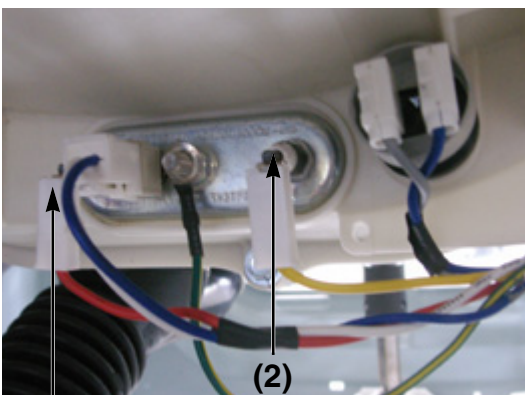
<p>Wiring diagram</p>	<div style="display: flex; justify-content: space-around;"> <div style="border: 1px solid gray; padding: 5px; background-color: #f0f0f0;"> <p style="text-align: center; margin: 0;">Circuit in the MAIN PWB</p>  <p style="text-align: center; margin: 0;">Heater driving circuit</p> </div> <div style="border: 1px solid gray; padding: 5px; background-color: #f0f0f0;"> <p style="text-align: center; margin: 0;">Wiring diagram</p>  <p style="text-align: center; margin: 0;">WASH HEATER</p> </div> </div> <p style="text-align: center; margin-top: 10px;">* Each circuits of loads in wiring diagram are all same.</p>				
<p>Function</p>	<ol style="list-style-type: none"> 1. The Wash Heater is designed to raise the wash water to the desired temperature selection during certain wash cycles. 2. The Steam generator heater is designed to make the water to the steam during steam cycles. 				
<p>Test points</p>	 <p style="text-align: center; margin-top: 5px;">(1) Wash Heater</p>				
<p>Result</p>	<p style="text-align: center; margin: 0;">Wash Heater</p> <table border="1" style="margin: 0 auto; border-collapse: collapse;"> <thead> <tr> <th style="padding: 5px;">Test Points</th> <th style="padding: 5px;">Result</th> </tr> </thead> <tbody> <tr> <td style="text-align: center; padding: 5px;">(1) to (2)</td> <td style="text-align: center; padding: 5px;">12-18 Ω</td> </tr> </tbody> </table>	Test Points	Result	(1) to (2)	12-18 Ω
Test Points	Result				
(1) to (2)	12-18 Ω				

9-7. THERMISTOR ASSEMBLY

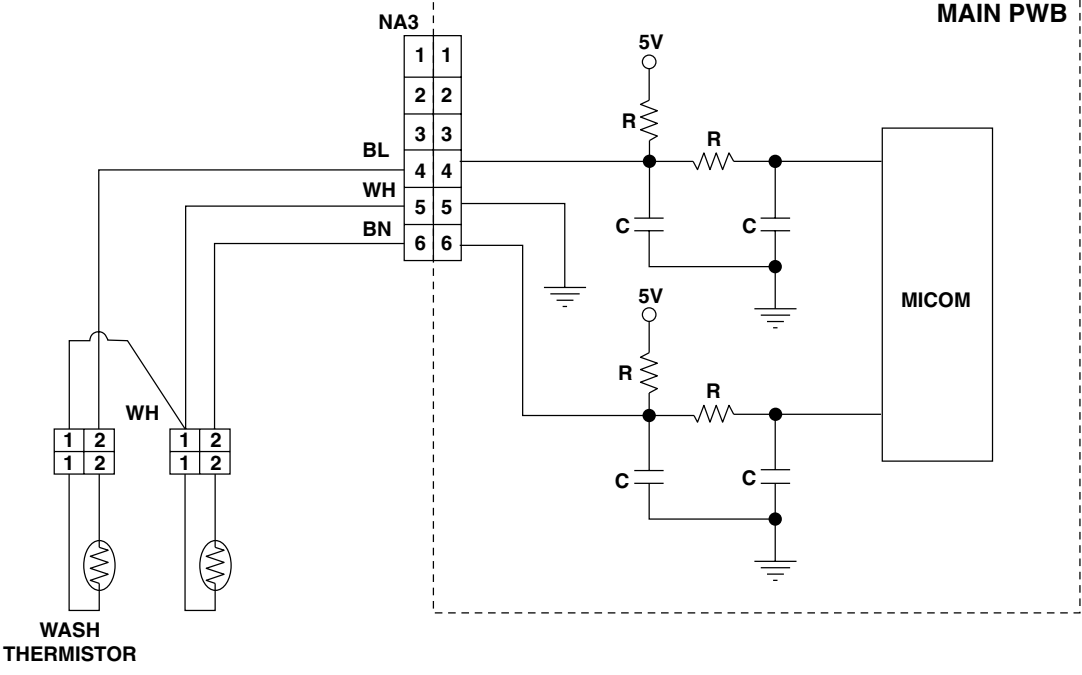
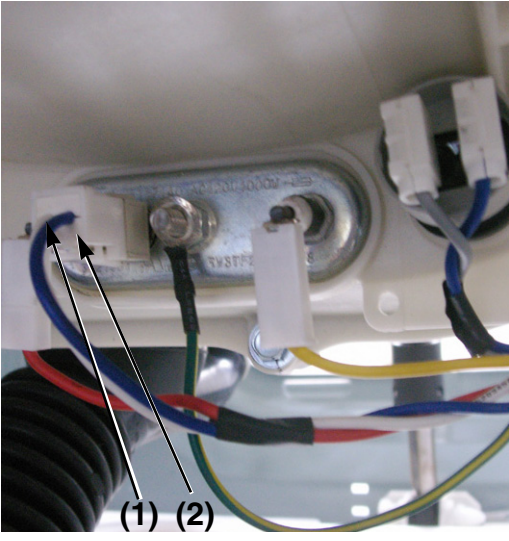
<p>Wiring diagram</p>	<p style="text-align: center;">Circuit in the MAIN PWB / Wiring Diagram</p>  <p>The diagram illustrates the electrical connection between two 'WASH THERMISTOR' sensors and the 'MAIN PWB'. Each sensor has two terminals labeled '1' and '2'. The sensors are connected to a 6-pin connector labeled 'NA3' (pins 1-6), a terminal labeled 'BL', a terminal labeled 'WH', and a terminal labeled 'BN'. The 'MAIN PWB' circuit includes two identical signal conditioning stages. Each stage consists of a 5V DC source, a resistor (R), and a capacitor (C) connected to ground. The output of each stage is connected to a 'MICOM' component. The 'WH' terminal is connected to the input of the top stage, and the 'BN' terminal is connected to the input of the bottom stage.</p>
<p>Function</p>	<p>The thermistor (temperature sensor) is used to monitor water temperature in the tub or Steam Generator.</p>
<p>Test points</p>	 <p style="text-align: center;">Wash Thermistor</p> <p>The photograph shows the physical 'Wash Thermistor' assembly. Two test points are indicated by arrows and labeled '(1)' and '(2)'. The assembly includes a metal base with a central screw and several colored wires (blue, green, yellow, red, black) connected to it.</p>

Result	Wash Thermistor		
	Test Points	Result (tolerance $\pm 5\%$)	Remarks
	(1) to (2)	39.5 k Ω	At 86°F (30°C)
		26.1 k Ω	At 104°F (40°C)
		12.1 k Ω	At 140°F (60°C)
		8.5 k Ω	At 158°F (70°C)
		3.8 k Ω	At 203°F (95°C)
		2.8 k Ω	At 221°F (105°C)

9-8. VIBRATION SENSOR ASSEMBLY

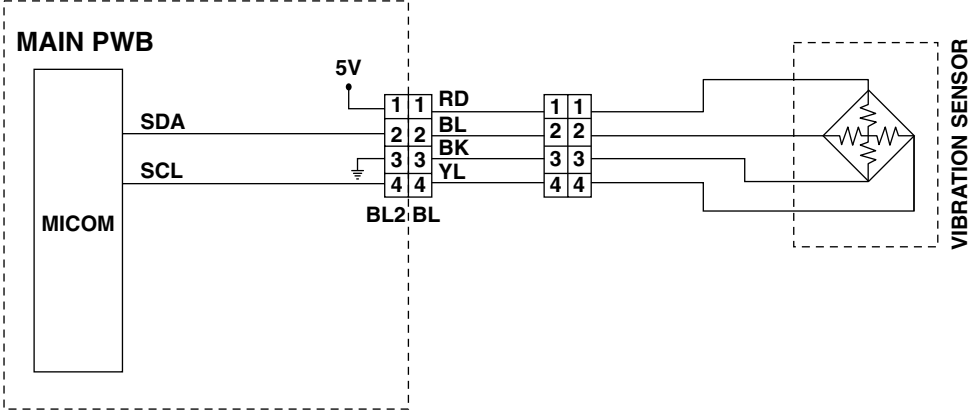
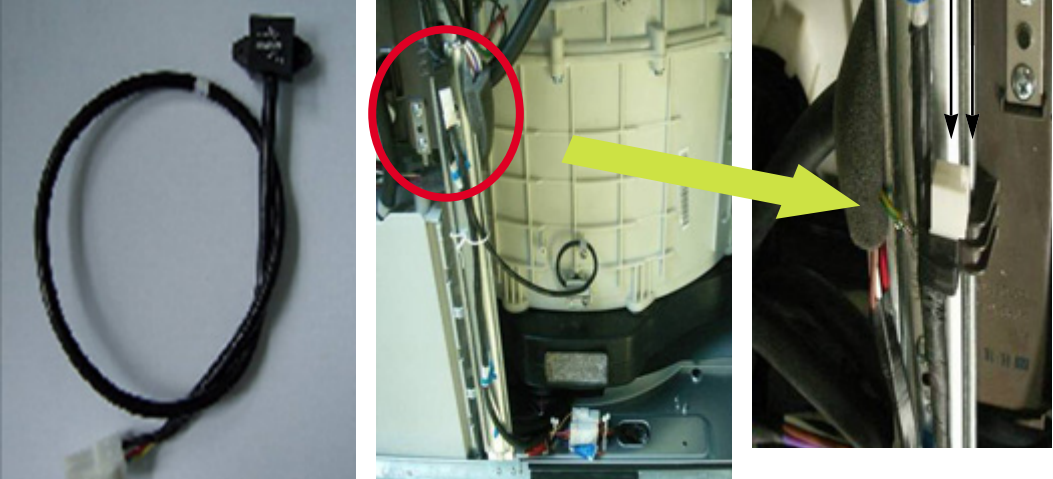
<p>Wiring diagram</p>	<p style="text-align: center;">Circuit in the MAIN PWB / Wiring Diagram</p> 						
<p>Function</p>	<p>The vibration sensor is designed to decrease the vibration of the washing machine. It is attached to the tub cover of washing machine. It estimates the vibration of washing machine's tub during drying. And, it reduces the vibration and the noise of washing machine.</p>						
<p>Test points</p>	<p style="text-align: center;">Vibration Sensor</p>  <p style="text-align: center;">Original</p>						
<p>Result</p>	<table border="1" style="width: 100%; border-collapse: collapse;"> <thead> <tr> <th style="width: 33%;">Test Points</th> <th style="width: 33%;">Result</th> <th style="width: 33%;">Remarks</th> </tr> </thead> <tbody> <tr> <td>(1) to (3)</td> <td>5.0 Vdc</td> <td>Voltage Input</td> </tr> </tbody> </table>	Test Points	Result	Remarks	(1) to (3)	5.0 Vdc	Voltage Input
Test Points	Result	Remarks					
(1) to (3)	5.0 Vdc	Voltage Input					

10. DISASSEMBLY INSTRUCTIONS

* Be sure to unplug the machine before disassembling and repairing the parts.

CONTROL PANEL

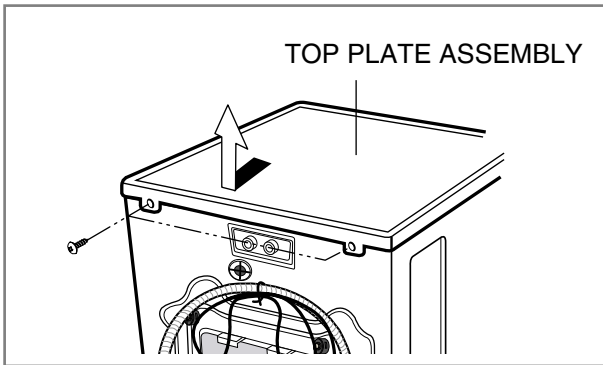

- ① Unscrew 2 screws on the back of the top plate.
- ② Pull the top plate backward and upward as shown.

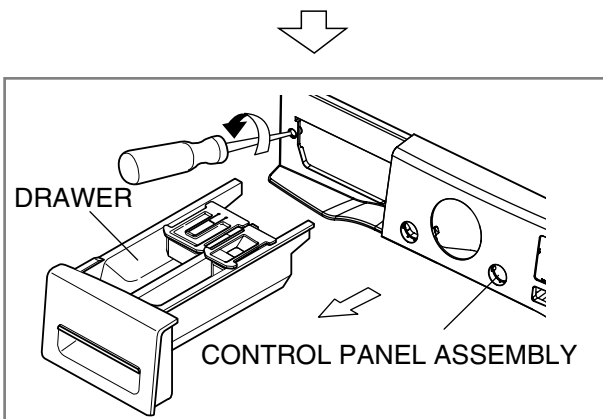

- ③ Disconnect the Display PWB assembly connector from trans cable.
- ④ Pull out the drawer and unscrew 2 screws.

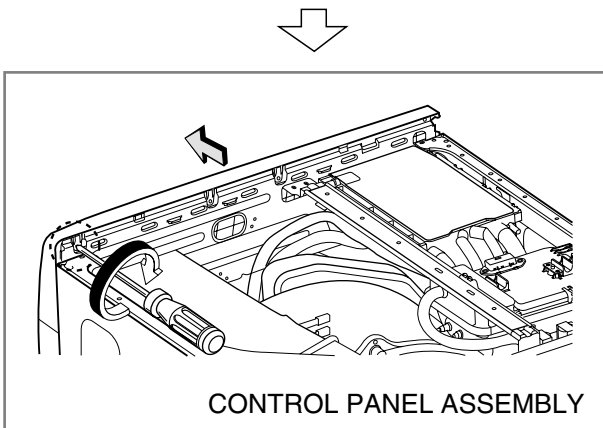

- ⑤ Remove one screw.
- ⑥ Lift the side the control panel assembly and pull it out.

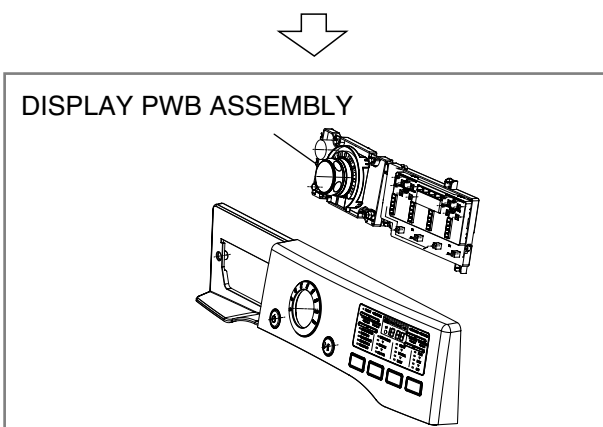

- ⑦ Unscrew the 8 screws from the control panel assembly.
- ⑧ Disassemble the Display PWB Assembly.

MAIN PWB ASSEMBLY

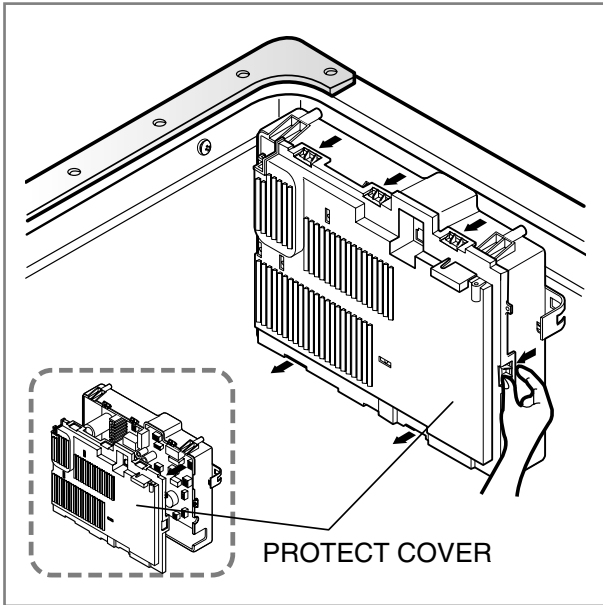

- ① Disconnect the POWER connector and SENSOR SWITCH ASSEMBLY.
- ② Remove the Protective cover.

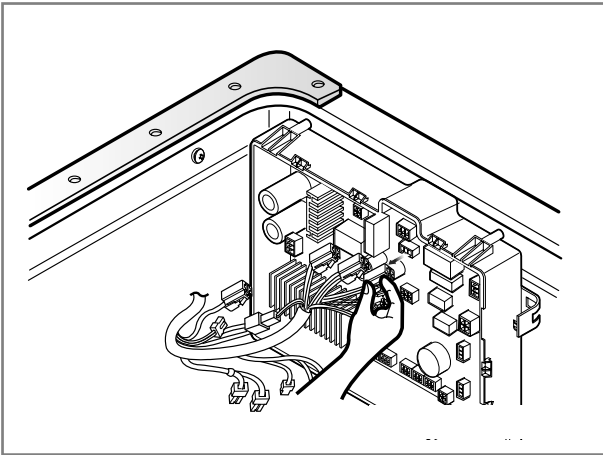

- ③ Disconnect the connectors.

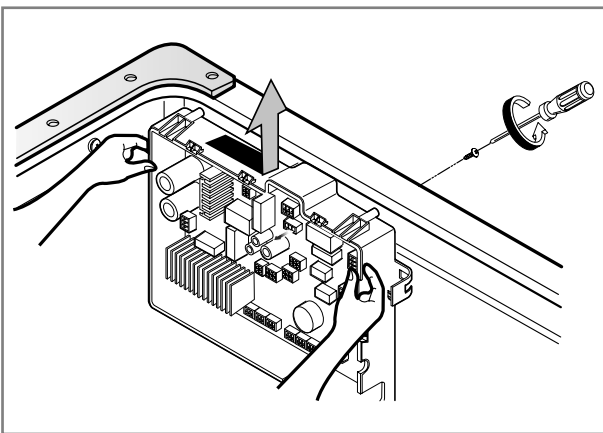

- ④ Unscrew 1 screw on the back.
- ⑤ Remove the Main PWB.

DISPENSER ASSEMBLY

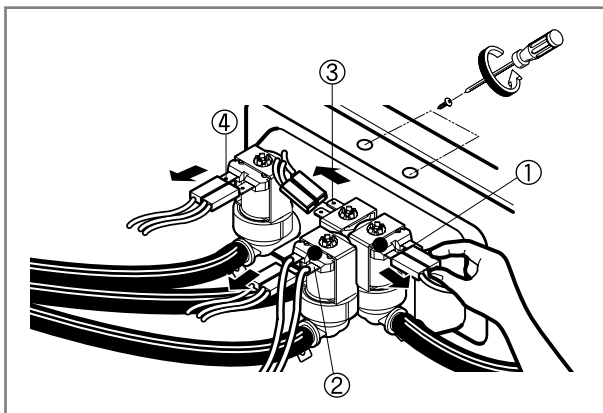
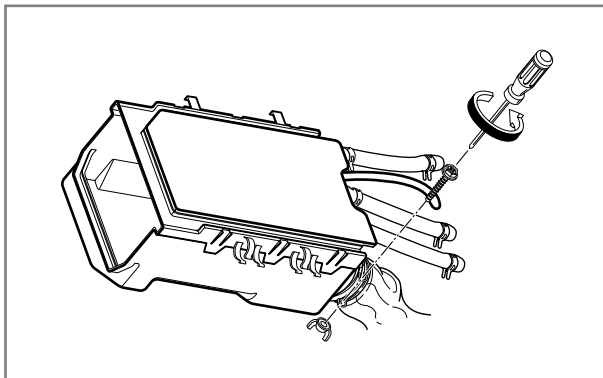
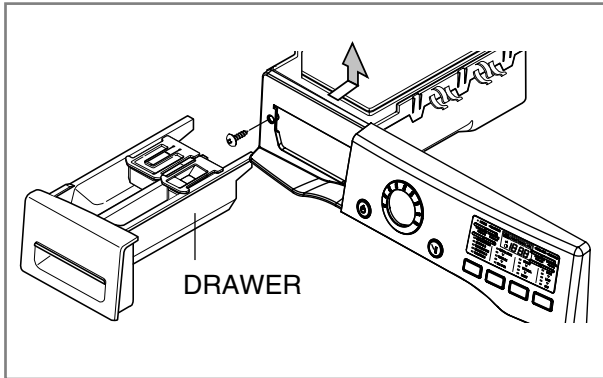

- ① Disassemble the top plate assembly.
- ② Pull out the drawer.
- ③ Push out the DISPENSER ASSEMBLY after unscrewing 2 screws.

- ④ Unscrew the Clamp nut at the lower part of the dispenser.

- ⑤ Disassemble the 4 connectors from the valves.

※ Wire Color

- ① Blue Housing (YL-BK)
- ② Red Housing (VT-BK)
- ③ White Housing (WH-BK)
- ④ Blue Housing (GY-BK)
- ⑤ Red Housing (BL-BK)

- ⑥ Unscrew 2 screws from the back of the cabinet.

NOISE FILTER

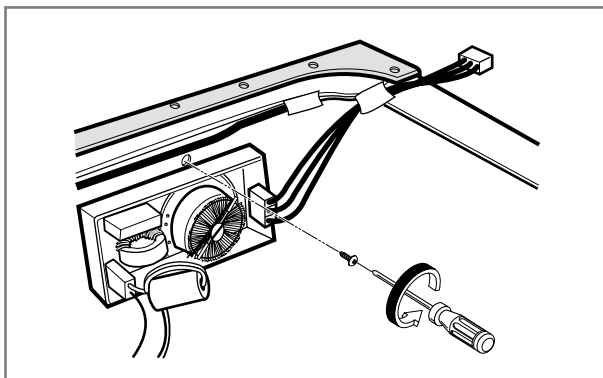

- ① Disassemble two (or three) connectors from the NOISE FILTER.

- ② Unscrew a screw from the TOP BRACKET.

CABINET COVER

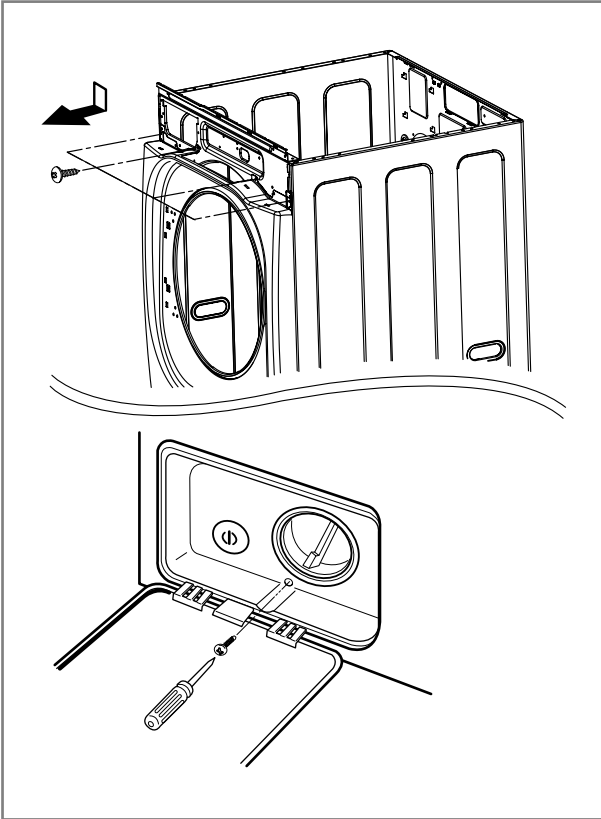

- ① Unscrew the 5 screws from upper of the cabinet cover.
- ② Unscrew the screw from filter cover.

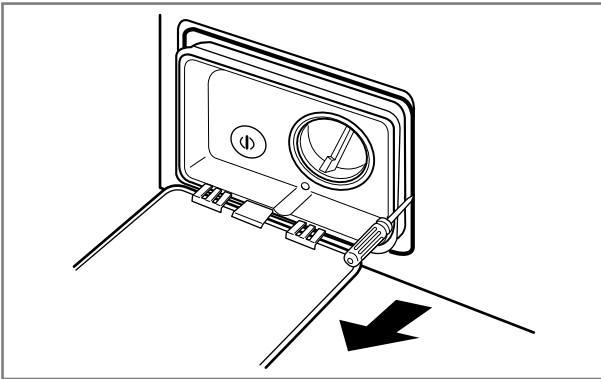

- ③ Put a flat (-) screwdriver or putty knife into the hinge slots at the bottom of the cover and pry it out.

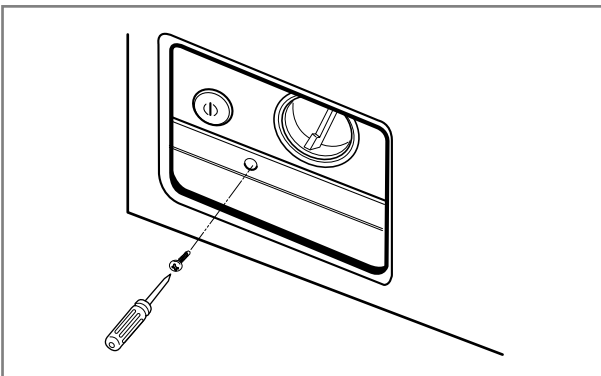

- ④ Unscrew the screw from the lower side of the cabinet cover.

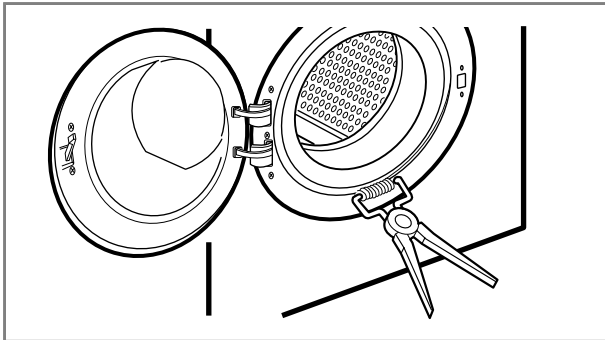

- ⑤ Open the door.
- ⑥ Disassemble the clamp assembly.

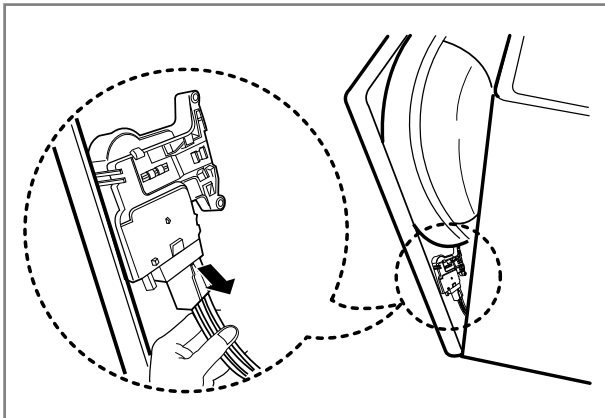

- ⑦ Tilt the cabinet cover.
- ⑧ Disconnect the door switch connector.

※ **NOTE** : When assembling the CABINET COVER, connect the door switch connector.

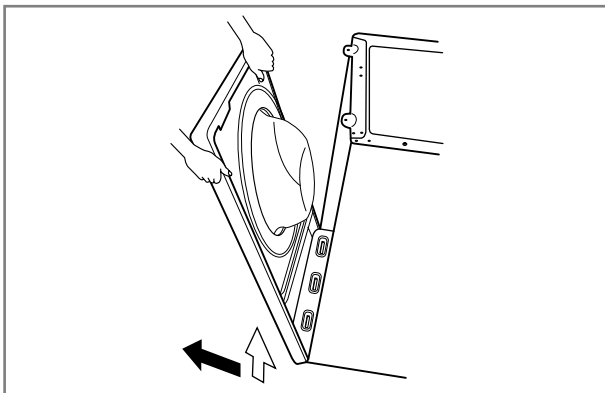

- ⑨ Lift and separate the cabinet cover.

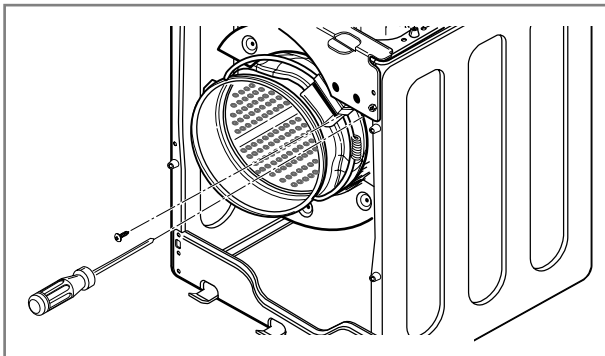

- ⑩ Disassemble the clamp assembly.
- ⑪ Disassemble the gasket.

DOOR

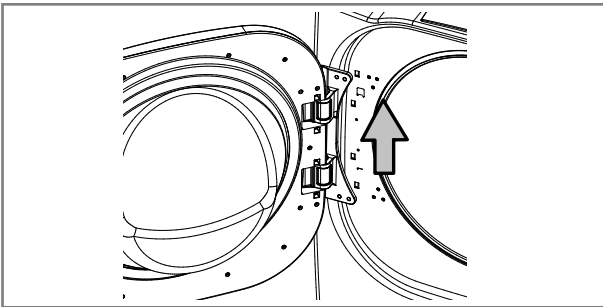
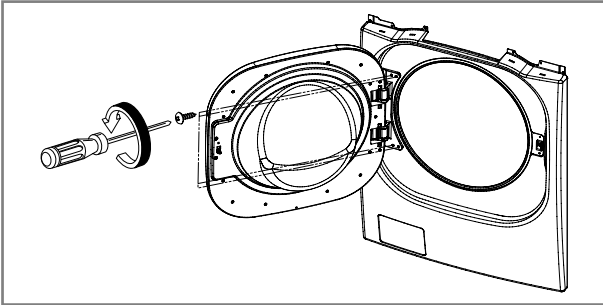

- ① Open the door.
- ② Unscrew the 4 screws from the hinge.
(Use the 8mm tool.)
- ③ Disassemble the door upward.

DOOR LOCK SWITCH ASSEMBLY

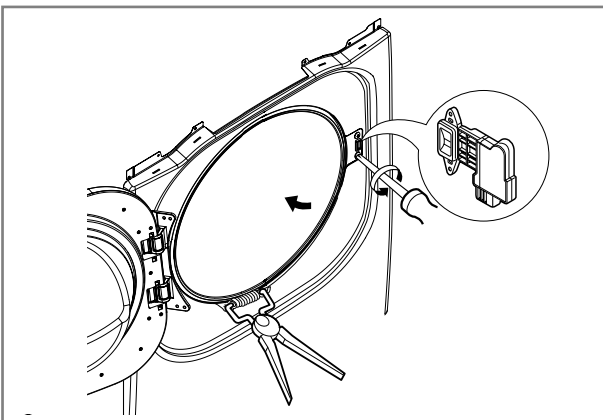

- ① Open the door and disassemble the CLAMP ASSEMBLY.
- ② Unscrew the 2 screws.

※ NOTE

- Reconnect the connector after replacing the DOOR SWITCH ASSEMBLY.

PUMP

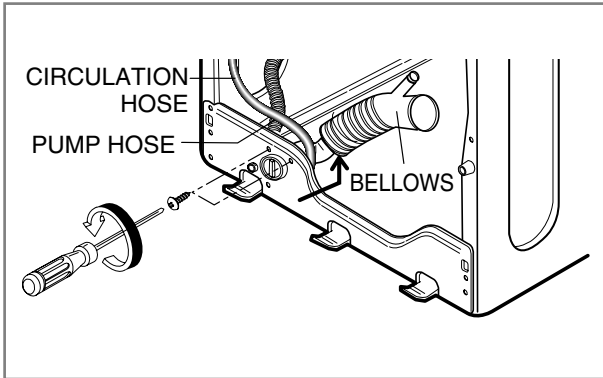

- ① Disassemble the cabinet cover.
- ② Separate the pump hose, the bellows and the circulation hose assembly from the pump assembly.
- ③ Disassemble the pump assembly in arrow direction.

HEATER

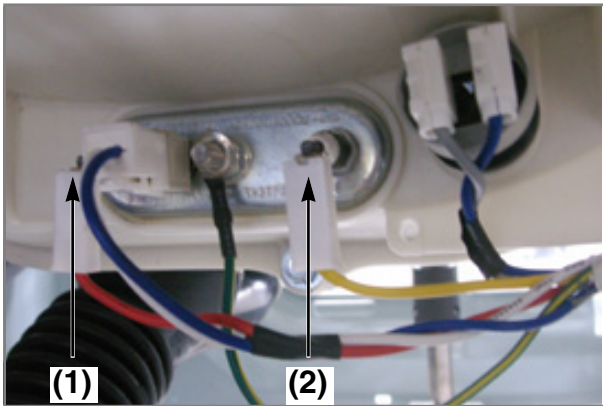

- ① Disassemble the cabinet cover.
- ② Separate 2 connectors from the heater.
- ③ Loosen the nut and pull out the heater.

※ CAUTION

- When assembling the heater, insert the heater into the heater clip on the bottom of the tub.
- Tighten the fastening nut so the heater is secure.

THERMISTOR

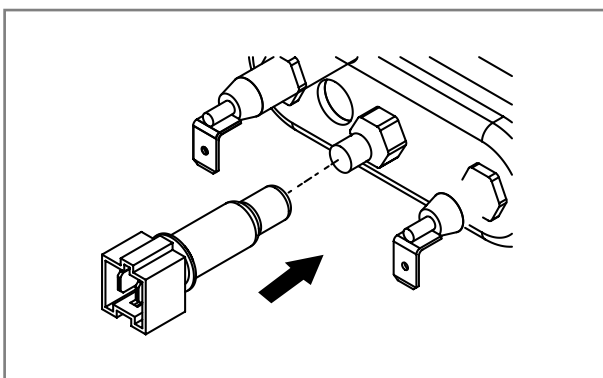

- ① Disassemble the cabinet cover.
- ② Unplug the white connector from the thermistor.
- ③ Pull it out by holding the bracket of the thermistor.

WHEN FOREIGN OBJECT IS STUCK BETWEEN DRUM AND TUB

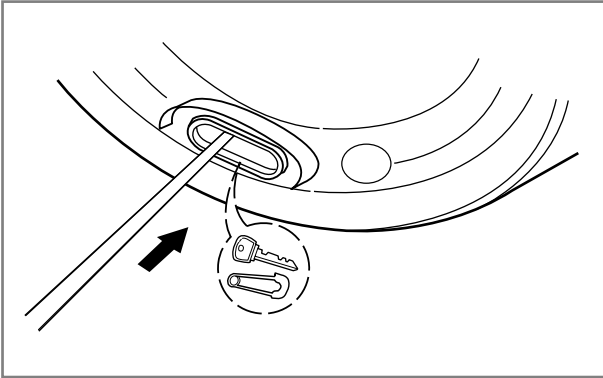

- ① Disassemble the cabinet cover.
- ② Separate the heater from the tub.
- ③ Remove any foreign objects (wire, coin, etc.) by inserting a long bar in the opening.

MOTOR/DAMPER

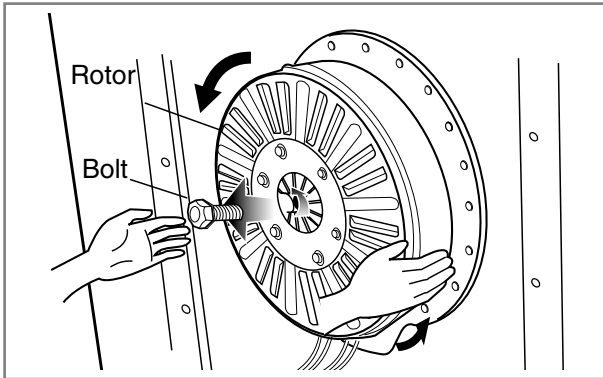

- ① Disassemble the back cover.
- ② Remove the bolt.
- ③ Pull out the Rotor.

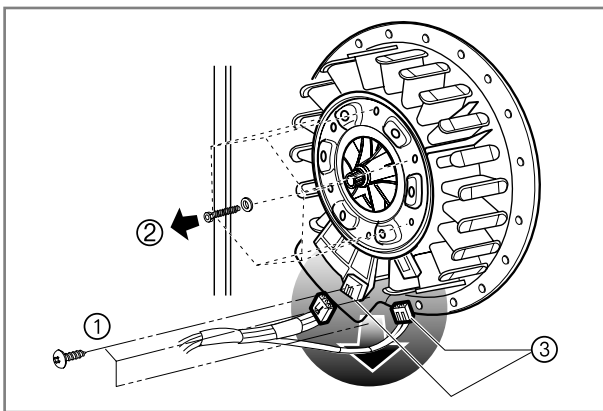

- ① Unscrew the 2 screws from the tub bracket.
- ② Remove the 6 bolts on the stator.
- ③ Unplug the 2 connectors from the stator.

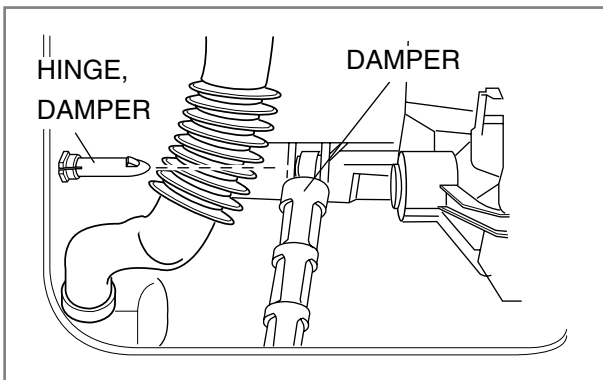

- ① Disassemble the damper hinges from the tub and base.

※ NOTE

- If you pull the dampers apart, they must be replaced. If you do not separate them, they can be re-used.

11. EXPLODED VIEW

11-1. CABINET & CONTROL PANEL ASSEMBLY

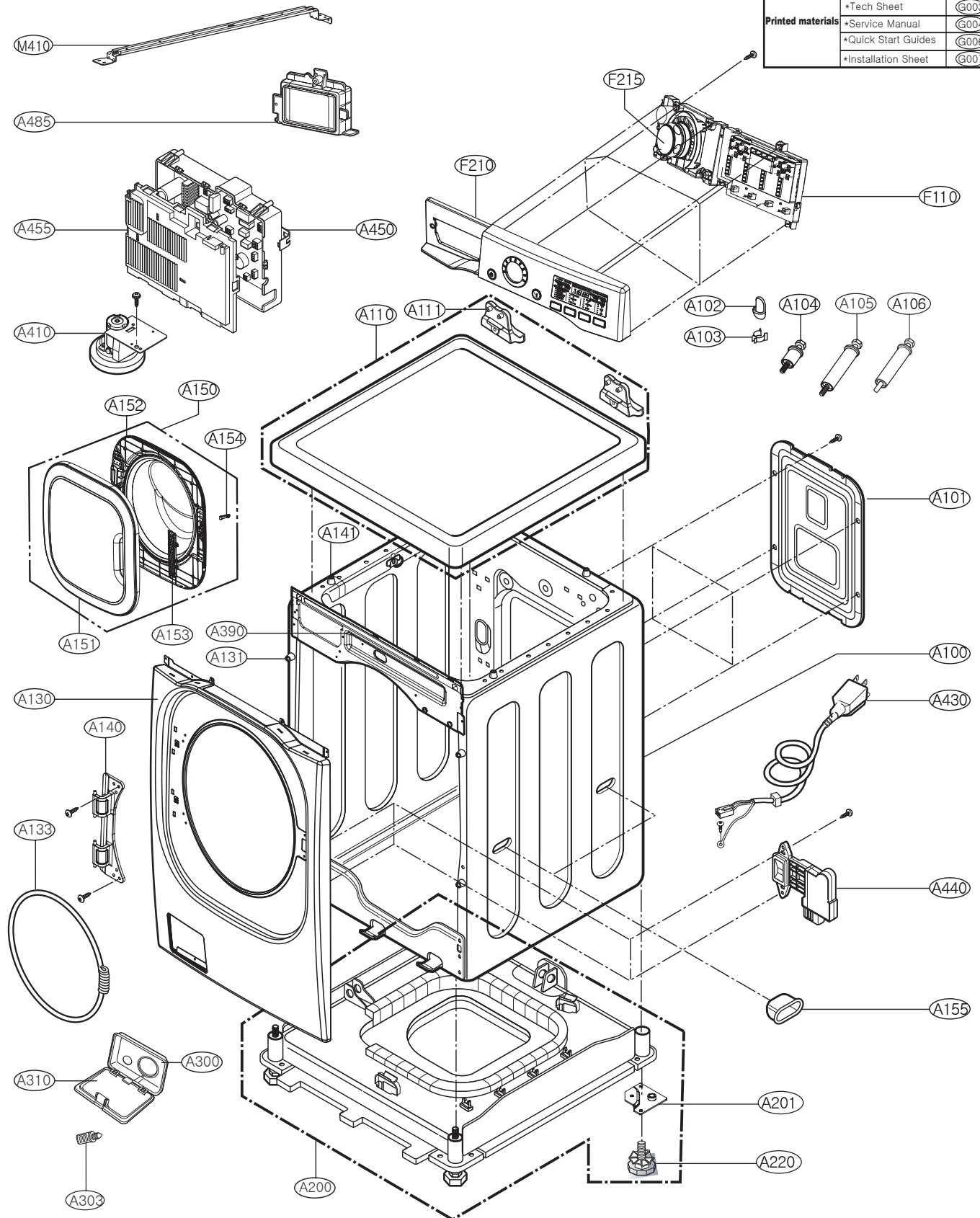

11-2. DRUM & TUB ASSEMBLY

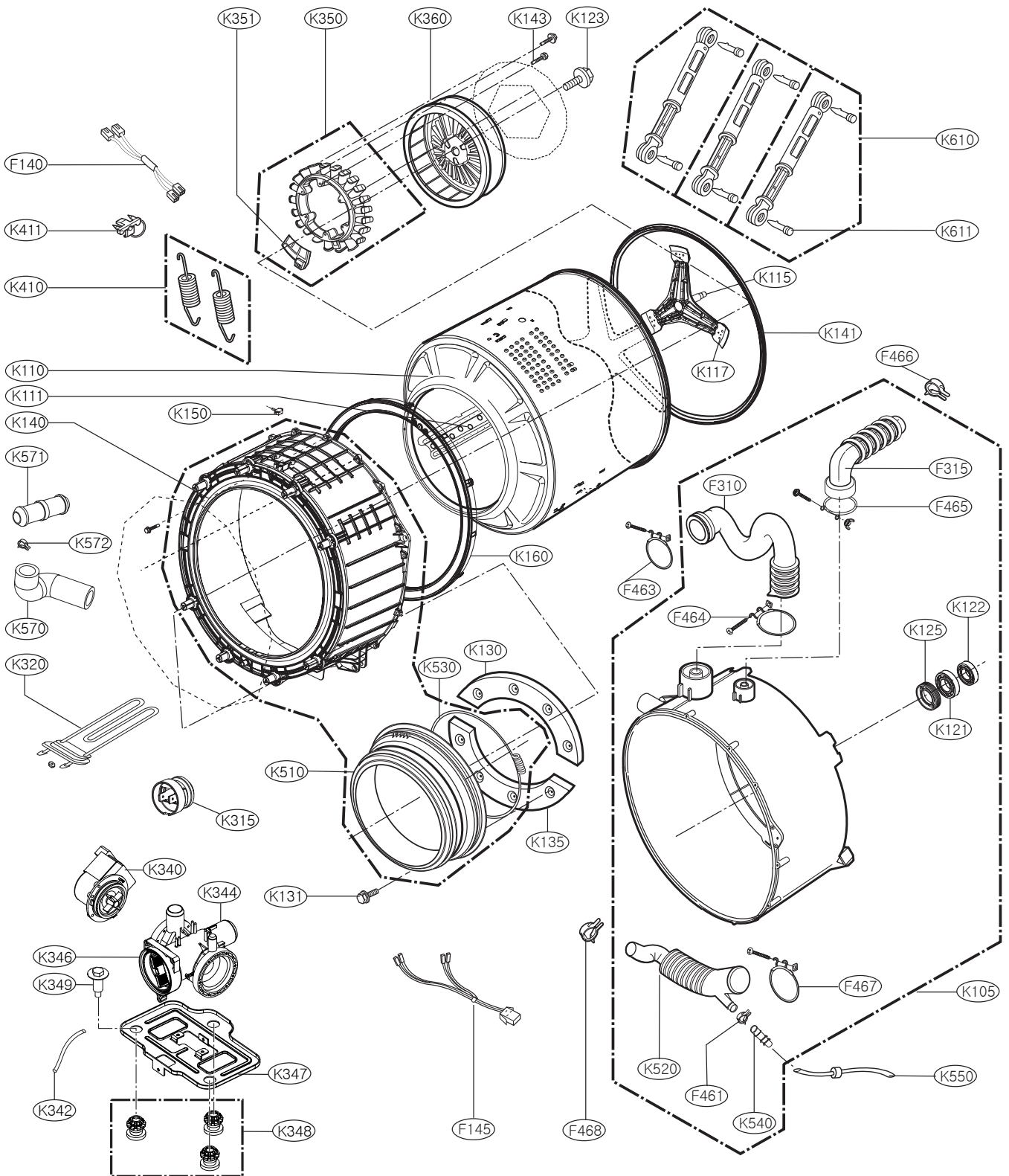

11-3. DISPENSER ASSEMBLY

