

This Owner's Manual is provided and hosted by [Appliance Factory Parts](#).



LG WM2501HWA Owner's Manual

[Shop genuine replacement parts for LG WM2501HWA](#)



[Find Your LG Washer Parts - Select From 393 Models](#)

----- Manual continues below -----

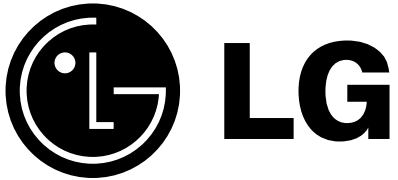

Website: <http://www.LGService.com>
E-mail: <http://www.LGService.com/techsup.html>

WASHING MACHINE SERVICE MANUAL

▲ CAUTION

READ THIS MANUAL CAREFULLY TO DIAGNOSE
PROBLEMS CORRECTLY BEFORE SERVICING THE UNIT.

MODEL: WM2501H*A



July. 2009 PRINTED IN KOREA

P/No.: MFL30599142

CONTENTS

1. SPECIFICATIONS	3
2. FEATURES AND TECHNICAL EXPLANATION	4
3. PARTS IDENTIFICATION	7
4. INSTALLATION AND TEST	8
5. OPERATION	11
5-1. CONTROL PANEL FEATURES	11
5-2. CYCLE GUIDE	13
5-3. SPECIAL FUNCTIONS	14
5-4. EXPLANATION OF EACH PROCESS	15
6. WIRING DIAGRAM/PROGRAM CHART	17
7. TEST MODE	19
7-1. SAFETY CAUTION	19
7-2. LOAD TEST MODE	19
7-3. HOW TO CHECK THE WATER LEVEL FREQUENCY	19
8. TROUBLESHOOTING	20
8-1. SAFETY CAUTION	20
8-2. ERROR MODE SUMMARY	20
8-3. TROUBLESHOOTING SUMMARY	22
8-4. TROUBLESHOOTING WITH ERROR	23
8-5. TROUBLESHOOTING ELSE	30
9. COMPONENT TESTING INFORMATION	35
9-1. FILTER ASSEMBLY (LINE FILTER)	35
9-2. DOOR LOOK SWITCH ASSEMBLY	36
9-3. STATOR ASSEMBLY	38
9-4. PUMP MOTOR ASSEMBLY	41
9-5. INLET VALVE ASSEMBLY	42
9-6. HEATER ASSEMBLY	43
9-7. THERMISTOR ASSEMBLY	44
9-8. STEAM GENERATOR ASSEMBLY	46
9-9. LA□	
10. DISASSEMBLY INSTRUCTIONS	49
11. EXPLODED VIEW	60
11-1. CABINET AND CONTROL PANEL ASSEMBLY	60
11-2. DRUM AND TUB ASSEMBLY	61
11-3. DISPENSER ASSEMBLY	62

1. SPECIFICATIONS

ITEM		WM2501H*A
COLOR		W:BLUE WHITE, V:STAINLESS SILVER, R:CANDY APPLE RED
POWER SUPPLY		AC 120 V, 60 Hz
PRODUCT WEIGHT		192 lbs (87kg)
ELECTRIC POWER CONSUMTION	WASHING	280 W
	DRAIN MOTOR	80 W
	WASH HEATER	1000 W
REVOLUTION SPEED	WASH	46 rpm
	SPIN	0-1200 rpm
CYCLES		9
WASH/RINSE TEMPERATURES		5
SPIN SPEEDS		5
OPTIONS		Prewash, Rinse+Spin, Extra Rinse, Water Plus, Stain Cycle
WATER CIRCULATION		Incorporated
OPERATIONAL WATER PRESSURE		14.5–116 psi (100-800 kPa)
CONTROL TYPE		Electronic
WASH CAPACITY [cu.ft]		3.63 (4.2 IEC)
DIMENSIONS		27" (W) X 29 ³ / ₄ " (D) X 38 ¹¹ / ₁₆ " (H), 50 ¹³ / ₁₆ " (D, door open)
DELAY WASH		up to 19 hours
DOOR SWITCH TYPE		PTC + Solenoid
WATER LEVEL		10 steps (by sensor)
LAUNDRY LOAD SENSING		Incorporated
ERROR DIAGNOSIS		Incorporated
AUTO POWER OFF		Incorporated
CHILD LOCK		Incorporated
RLM ENABLE		–
STEAM		Incorporated

2. FEATURES & TECHNICAL EXPLANATION

2-1. FEATURES



■ Ultra Capacity

The Larger drum enables not just higher head drop and stronger centrifugal force, but also less tangling and wrinkling of the laundry. Heavier loads, such as king size comforters, blankets, and curtains, can be washed.



■ Direct Drive System

The advanced Brushless DC motor directly drives the drum without belt and pulley.

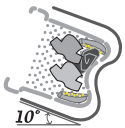

■ Tilted Drum and Extra Large Door Opening

Tilted drum and extra large opening make it possible to load and unload clothing more easily.

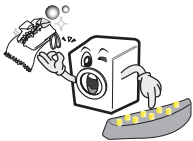

■ RollerJets

Washing ball enhances the wash performance and reduces damage to the clothing. The jets spray and help tumble clothes to enhance washing performance while maintaining fabric care.



■ Automatic Wash Load Detection

Automatically detects the load and optimizes the washing time.



■ Built-in Heater

Internal heater helps to maintain water temperature at its optimum level for selected cycles.



■ Child Lock

The Child lock prevents children from pressing any button to change the settings during operation.



■ Steam Washing and SteamFresh™

Steam Washing features upgraded washing performance with low energy and water consumption. SteamFresh™ cycle removes wrinkles from dry clothes.

2-2. NEURO FUZZY WASHING TIME OPTIMIZATION

To get the best washing performance, optimal time is determined by the water temperature, the selected washing temperature, and the size of the load.

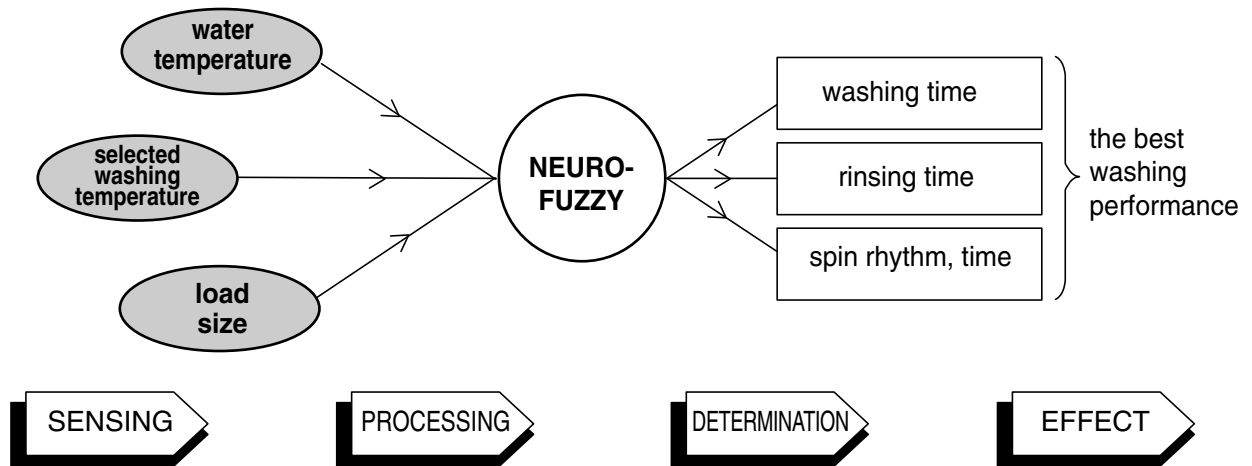

2-3. WATER LEVEL CONTROL

- This model incorporates a pressure sensor which can sense the water level in the tub.
- The water supply is stopped when the water level reaches the preset level, the washing program then proceeds.
- Spinning does not proceed until the water in the tub drains to a certain level.

2-4. DOOR CONTROL

- The door can be opened by pulling the door handle whenever washer is not in operation.
- When the cycle is completed, the DOOR LOCKED light will turn off.
- If a power failure has occurred while in operation, the door will unlock after 5 minutes.
- Clicking sounds can be heard when the door is locked/unlocked.

2-5. THE DOOR CAN NOT BE OPENED

- While program is operating.
- When a power failed and power plug is taken out in operation.
- While Door Lock lights turn on.
- While the motor is in the process of inertial rotating, through the operation is paused.

2-6. DOOR LOCKED LAMP LIGHTS

- When the frequency of water level is lower than 22.9 kHz
(It can be canceled when the frequency is more than 23.8 kHz)
- When the temperature inside the tub is higher than 45°C and water level is not 25.5 kHz
(It can be canceled when the water level is 25.5 kHz or the temperature inside the tub is lower than 40°C)

2-7. CHILD LOCK

- Use this option to prevent unwanted use of the washer. Press and hold PRE WASH button for 3 seconds to lock/unlock control.
- When child lock is set, CHILD LOCK lights and all buttons are disabled except the Power button. You can lock the controls of the wash while washing.

2-8. WATER CIRCULATION

- When washing and rinsing function of shower at the upper part of Gasket.
- When washing, it continuously operates for 3 minutes and intermittently.
- When rinsing, it continuously operates after completion of water supply.

2-9. STEAM

- For tough stained clothes, sick room linens or baby clothes.
- Steam Wash is available with Sanitary, Bulk/Large, Perm. Press, Cotton/Normal cycles.
- This option features upgraded washing performance with low energy and water consumption
- Do not load delicates such as wool, silk, and easily discolored clothes.

2-10. DRUM LIGHT

- The Drum Light comes on when the Power button is pressed. It goes off when the door is closed and the washer starts operation.
- The Drum Light remains off when the door is locked.
- The Drum Light can be turned on while the washer is in operation by pressing the Rinse+Spin button for 3 seconds. The light will turn off automatically 4 minutes later.
- The Drum Light comes on when the washing cycle is finished and goes off 4 minutes later.

3. PARTS IDENTIFICATION

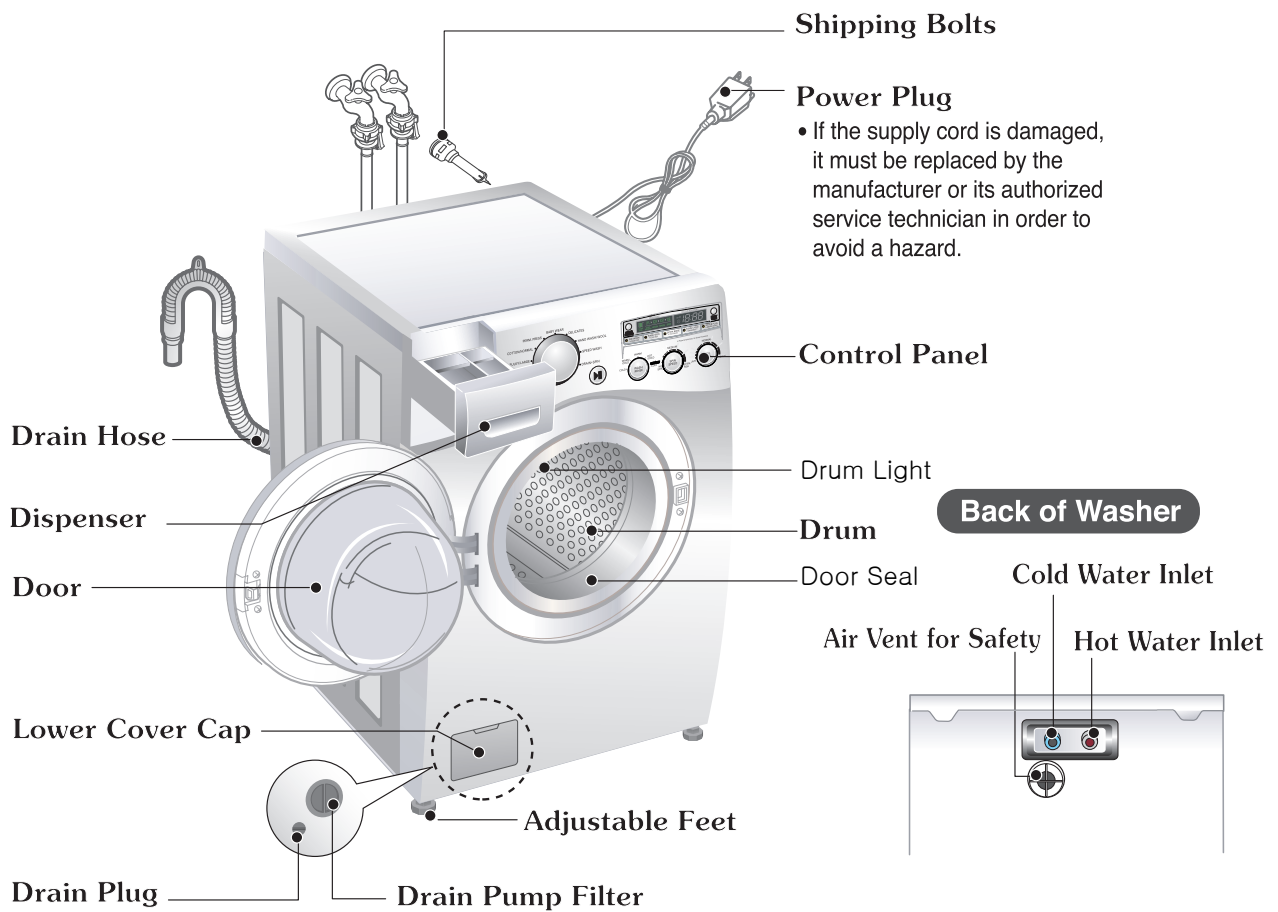

■ ACCESSORIES

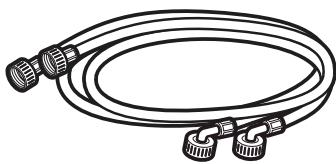

Hot/Cold (1 each) Hose

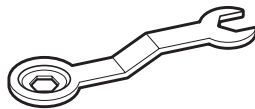

Wrench

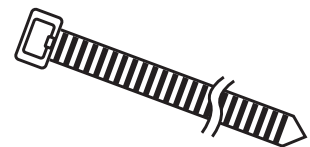

Tie strap (Option)
to secure drain hose to standpipe,
inlet hose, or laundry tub

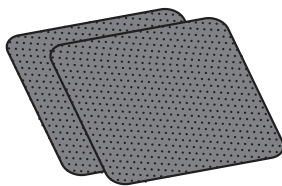

Non-skid pads

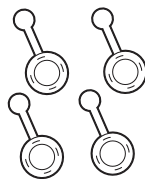

Caps(4)
(for covering shipping
bolt holes)

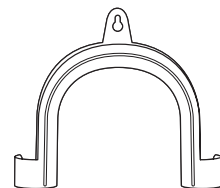

Elbow Bracket
(for securing drain hose)

4. INSTALLATION & TEST

- 1 Before servicing, ask the customer what the trouble is.
- 2 Check the setup (power supply is 120V, remove the transit bolts, level the washer...)
- 3 Check with the troubleshooting guide.
- 4 Plan your service method by referring to the disassembly instructions.
- 5 Service the unit.
- 6 After servicing, operate the appliance to see whether it functions correctly.

■ STANDARD INSTALLATION

The appliance should be installed as follows:

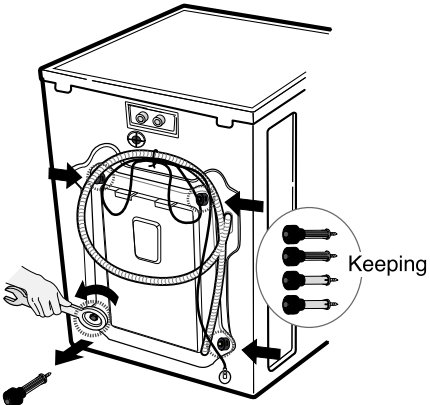
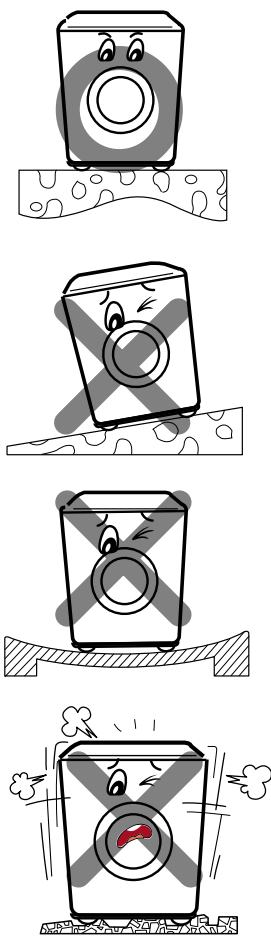
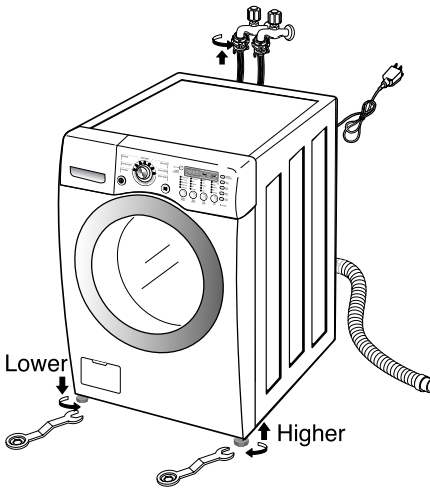
REMOVE THE SHIPPING BOLTS	INSTALL THE APPLIANCE ON A FLAT AND FIRM SURFACE	ADJUST THE LEVELING
<ul style="list-style-type: none"> • Remove the 4 shipping bolts with the supplied wrench. ※ Do first lower side to remove easily. • Keep the shipping bolts and spanner for future use. • Insert the 4 caps (provided) into the hole. 		<ul style="list-style-type: none"> • Turn the leveling feet to adjust the appliance.  <ul style="list-style-type: none"> • Turn clockwise to raise; counterclockwise to lower.

■ HOW TO CONNECT THE INLET HOSE

- Verify that the rubber washer is inside of the valve connector.
- Tighten the inlet hose securely to prevent leaks.

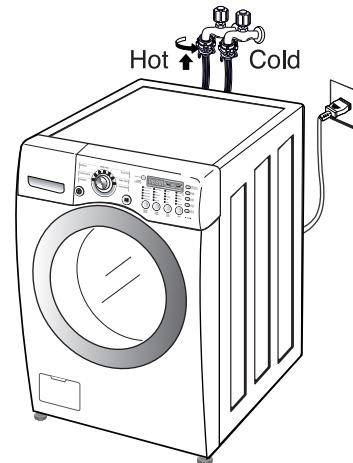

■ CONNECT THE DRAIN HOSE

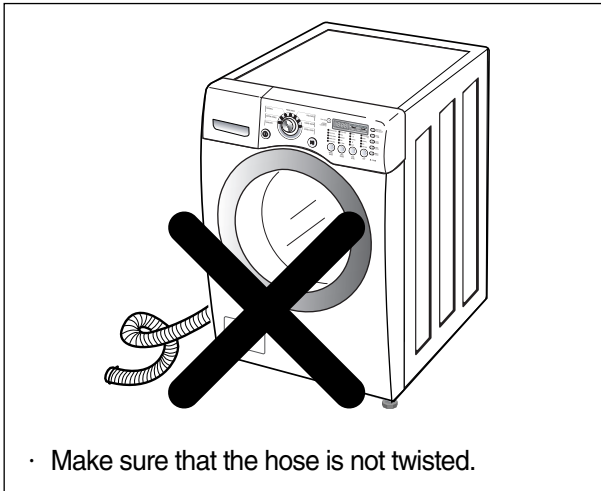

- Make sure that the hose is not twisted.

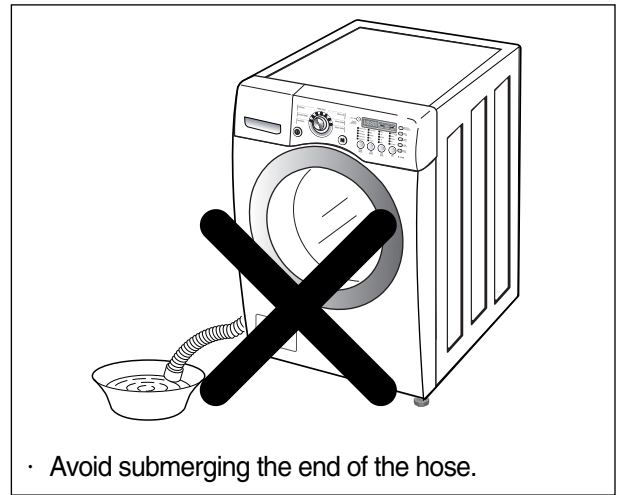

- Avoid submerging the end of the hose.

※ The end of the drain hose should be placed less than 96” from the floor.

■ CONNECT POWER PLUG

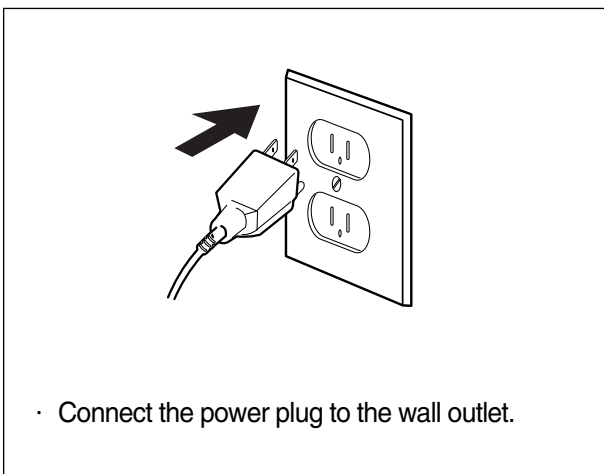

- Connect the power plug to the wall outlet.

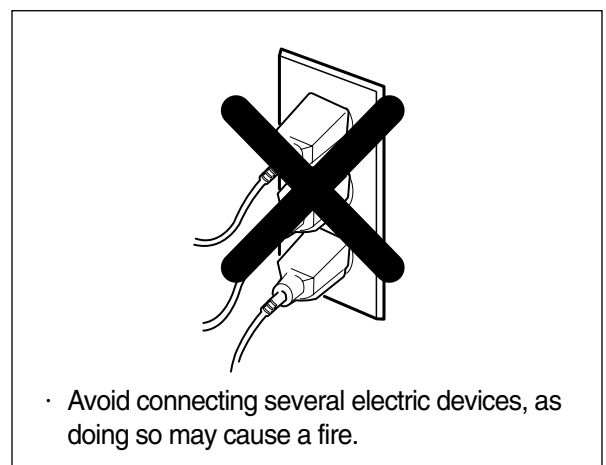

- Avoid connecting several electric devices, as doing so may cause a fire.

7 TEST OPERATION

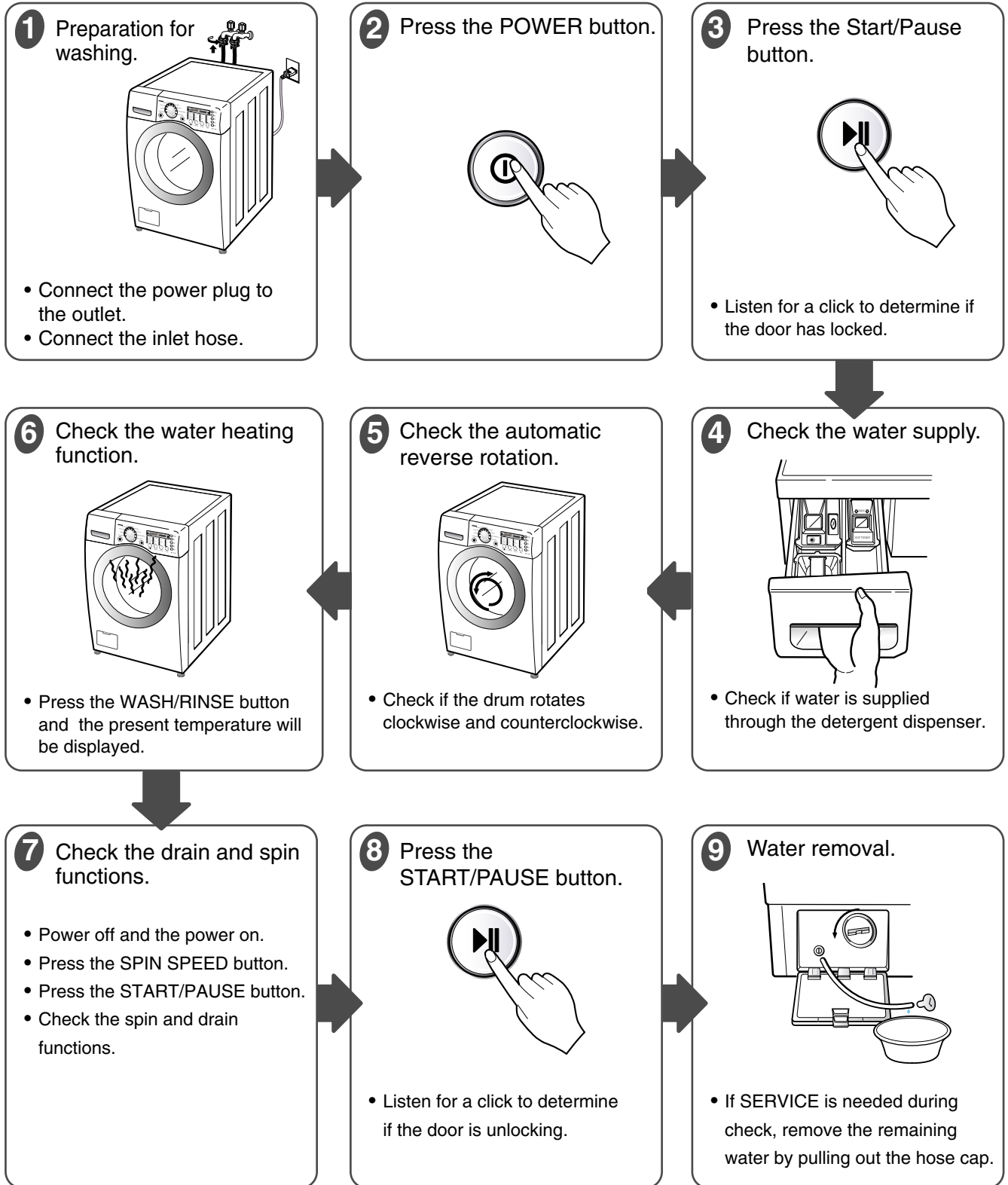

5. OPERATION

5-1. CONTROL PANEL FEATURES

■ WM2501H*A



STEAM, CUSTOM PROGRAM

- Delay Wash allows the start of any cycle to be delayed for 1~19 hours.
- **STEAM:** Use the STEAM button to add steam to the cycle for the extra cleaning.

EST. TIME REMAINING

- This display shows:
 - a) the estimated time remaining in the cycle when operation.
 - b) an error code when an error has been detected.

DOOR LOCKED lamp

- Light whenever the door of the washer is locked.
- The door can be unlocked by pressing the **Start/Pause** button to stop the washer.

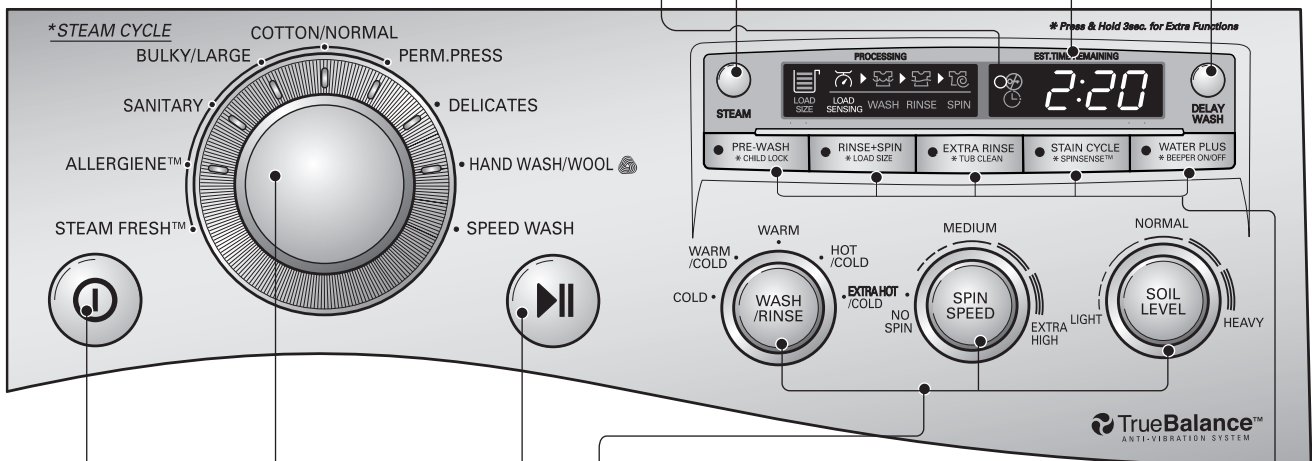

POWER button

- Use this button to turn power **On/Off**.

START/PAUSE button

- Use this button to **start/stop** the washer.

OPTION button

- **Prewash:** Use this option for loads that need pretreatment. It adds 16 minutes prewash and drain.
- **Rinse + Spin:** Use this option to rinse and then spin.
- **EXTRA RINSE:** Select this option to rinse and spin a load separately from a regular cycle.
- **Stain Cycle:** Add time to the wash and rinse for better stain removal. Automatically provide a rinse.
- **WATER PLUS:** Select this option to add extra water to the wash and rinse cycles for superior results, especially with large or bulky items.

CYCLE SELECTOR

- Rotate the cycle selector knob to select the cycle designed for different types of fabric and soil level.

Wash, Rinse temp., Spin speed, Soil Level

- Select a water temperature based on the type of load you are washing.
- To change the spin speed, press the Spin Speed button repeatedly to cycle through available options.
- To change the soil level, press the Soil Level button repeatedly until the desired setting is on.

5-2. CYCLE GUIDE

The cycle guide below shows the options and recommended fabric types for each cycle.

Cycle	Fabric Type	Wash/Rinse Temp.	Spin Speed	Soil Level	Pre-Wash	Rinse + Spin	Extra Rinse	Stain Cycle	Water Plus	Steam
Steam Fresh™	Dress shirts, blouses									●
SANITARY	Heavily soiled underwear, work clothes, diapers, etc.	Extra Hot/Cold	High (≡)	Normal						
			Extra High (≡) No Spin (●) Low (---) Medium (—)	Heavy Light	●	●	●	●	●	●
BULKY/ LARGE	Large items such as blankets and comforters	Warm/Cold	Low (---)	Normal						
		Warm/Warm Hot/Cold Cold/Cold	Medium (—) No Spin (●)	Heavy Light	●	●	●	●	●	●
COTTON/ NORMAL	Cotton, linen, towels shirts, sheets, jeans mixed loads	Warm/Cold	High (≡)	Normal						
		Warm/Warm Hot/Cold Cold/Cold	Extra High (≡) No Spin (●) Low (---) Medium (—)	Heavy Light	●	●	●	●	●	●
PERM. PRESS	Dress shirts/pants, wrinkle-free clothing, poly/cotton blend clothing, tablecloths	Warm/Cold	Medium (—)	Normal						
		Warm/Warm Hot/Cold Cold/Cold	High (≡) No Spin (●) Low (---)	Heavy Light	●	●	●	●	●	●
Allergiene™	Cotton, underwear, pillow covers, bed sheets, baby wear		High (≡) No Spin (●) Low (---) Medium (—)							●
DELICATES	Dress shirts/blouses nylons, sheer or lacy garments	Cold/Cold	Medium (—)	Normal						
		Warm/Cold Warm/Warm	No Spin (●) Low (---)	Heavy Light	●	●	●		●	
HAND WASH/ WOOL 	Items labeled "hand washable"	Warm/Cold	Low (---)	Normal						
		Warm/Warm Cold/Cold	No Spin (●)	Light		●	●		●	
SPEED WASH	Lightly soiled clothing and small loads	Hot/Cold	Extra High (≡)	Light						
		Cold/Cold Warm/Cold Warm/Warm	No Spin (●) Low (---) Medium (—) High (≡)	Normal Heavy		●	●		●	

NOTE: To protect your garments, not every wash/rinse temperature, spin speed, soil level, or option is available with every cycle.

5-3. SPECIAL FUNCTIONS

The option buttons also activate special functions, including CHILD LOCK, LOAD SIZE, TUB CLEAN, and SPIN SENSE. Press and hold the option button marked with the special function for 3 seconds to activate.

CHILD LOCK



Use this option to prevent unwanted use of the washer or to keep cycle settings from being changed while the washer is operating. Press and hold the PREWASH button for 3 seconds to activate or deactivate CHILD LOCK. CHILD LOCK will be shown in the display, and all controls are disabled except the ON/OFF button. The washer can be locked during a cycle.

LOAD SIZE

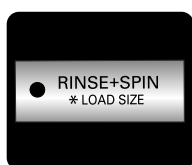

At the beginning of the cycle, the washer tumbles the load and detects the weight of the clothes.

The display will indicate the approximate load size in the LOAD SIZE display. This allows you to Adjust the amount of detergent and other additives for best results and improved efficiency.

TUB CLEAN



A buildup of detergent residue can occur in the wash tub over time and can lead to a mildew or musty smell. The TUB CLEAN cycle is specially designed to remove this buildup. Press and hold the EXTRA RINSE button for 3 seconds to activate this cycle. The display will show a message to add liquid bleach to the dispenser. After the cycle has ended, open the door and allow the drum interior to dry completely.

NOTE: Do NOT use this cycle with clothes, and do NOT add detergent or fabric softener.

SPIN SENSE

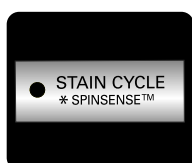

To activate SPINSENSE :

While the washing machine is running in any cycle, press and hold the STAIN CYCLE button for 3 seconds. The SPIN SPEED button light will blink while the washer is running to show that SPINSENSE is active. The SPINSENSE function will remain active for every cycle, even after a power failure.

To cancel SPINSENSE :

Press and hold the STAIN CYCLE button for 3 seconds to turn off the SPINSENSE function

BEEPER ON/OFF



You may turn the end-of-cycle beeper on or off with the WATER PLUS button during the cycle. Press and hold the WATER PLUS button for 3 seconds to turn the beeper off. Press and hold the WATER PLUS button again for 3 seconds to turn the beeper back on.

5-4. EXPLANATION OF EACH PROCESS

No.	Process	Explanation
1.	Stay	<ul style="list-style-type: none"> • Electrical power is supplied • Washer is ready to work and the micom is in the active mode.
2.	Water supply	<ul style="list-style-type: none"> • After loading laundry and selecting a course and a cycle, water is supplied and drum rotates. • When a user selects Pre-wash course, water is supplied through pre wash valve.
3.	Soaking & washing laundry	<ul style="list-style-type: none"> • To get laundry wet, drum rotates clockwise and counterclockwise. • If water amount is insufficient at this time, the Inlet valve will supply water again.
4.	Heating & washing	<ul style="list-style-type: none"> • The heater heats the water in drum to the selected water temperature and drum rotates for washing.
5. ~ 6.	Washing & heating / washing	<ul style="list-style-type: none"> • When the water temperature reaches to the selected temperature, the heating stops and only the drum rotates. • If water temperature becomes lower than selected because of re-supplied water, the heating starts again.
7.	Washing	<ul style="list-style-type: none"> • Fuzzy Logic decides washing time according to the laundry load, water temperature, and other factors.
8.	Drainage	<ul style="list-style-type: none"> • A pump motor drains the water from the drum. • After sensing drained water amount by water level frequency, spin starts. • When a heating course is selected, stay cooling process is performed to decrease the water temperature gradually to prevent laundry from being damaged and for safety reasons.
9.	Untangling (Sensing eccentricity)	<ul style="list-style-type: none"> • It balances laundry load and senses the eccentricity of the load, to only allow spinning without vibration • If the eccentricity is worse than the allowed level, it repeats the disentangling process. When the repeated time is more than allowed level, it displays UE. • If the eccentricity is good, the intermittent spin starts. • During this process, the drain pump works for drainage intermittently.

No.	Process	Explanation
A.	Intermittent spin	<ul style="list-style-type: none"> To reach the correct set speed, the motor rotates clockwise and counterclockwise directions after spin process starts. If the water level frequency is lower than 23.0 kHz, a washer senses suds and starts suds removal process.
B.	Rinse spin	<ul style="list-style-type: none"> In this process, the remaining water during washing process is extracted and the selected speed is kept. Removing suds process is in active mode at this cycle.
C.	Remaining spin	<ul style="list-style-type: none"> After spin finishes, the drum rotates by remaining spin power until it stops. Motor power is off. This process is overlapped with next process.
D.	Rinse water supply	<ul style="list-style-type: none"> Water supply for rinse process
E.	Rinse	<ul style="list-style-type: none"> Rinsing process.
F.	Last drainage	<ul style="list-style-type: none"> After spin finishes and power is not supplied to motor, the drum rotates by remaining spin power If rinse hold is selected, the drainage is not proceeded after rinse finishes.
G.	Disentangling	<ul style="list-style-type: none"> The same as item 9.
H.	Intermittent spin	<ul style="list-style-type: none"> The same as item A.
I.	Main spin1	<ul style="list-style-type: none"> The same as item B.
J.	Main spin2	<ul style="list-style-type: none"> At the end of a main spin, the spin speed will reach the selected rpm.
K.	Remaining spin	<ul style="list-style-type: none"> The same with item C.
L.	Disentangling	<ul style="list-style-type: none"> After spin finishes, disentangling starts to remove unbalanced laundry.
M.	End	<ul style="list-style-type: none"> After 'end' signal is displayed, it stays for 8 seconds and power is automatically turned off. (Auto type door switch) After door switch is off, end signal is displayed in the case of manual type and it takes around 2 minute to turn off door switch.

6. WIRING DIAGRAM/PROGRAM CHART

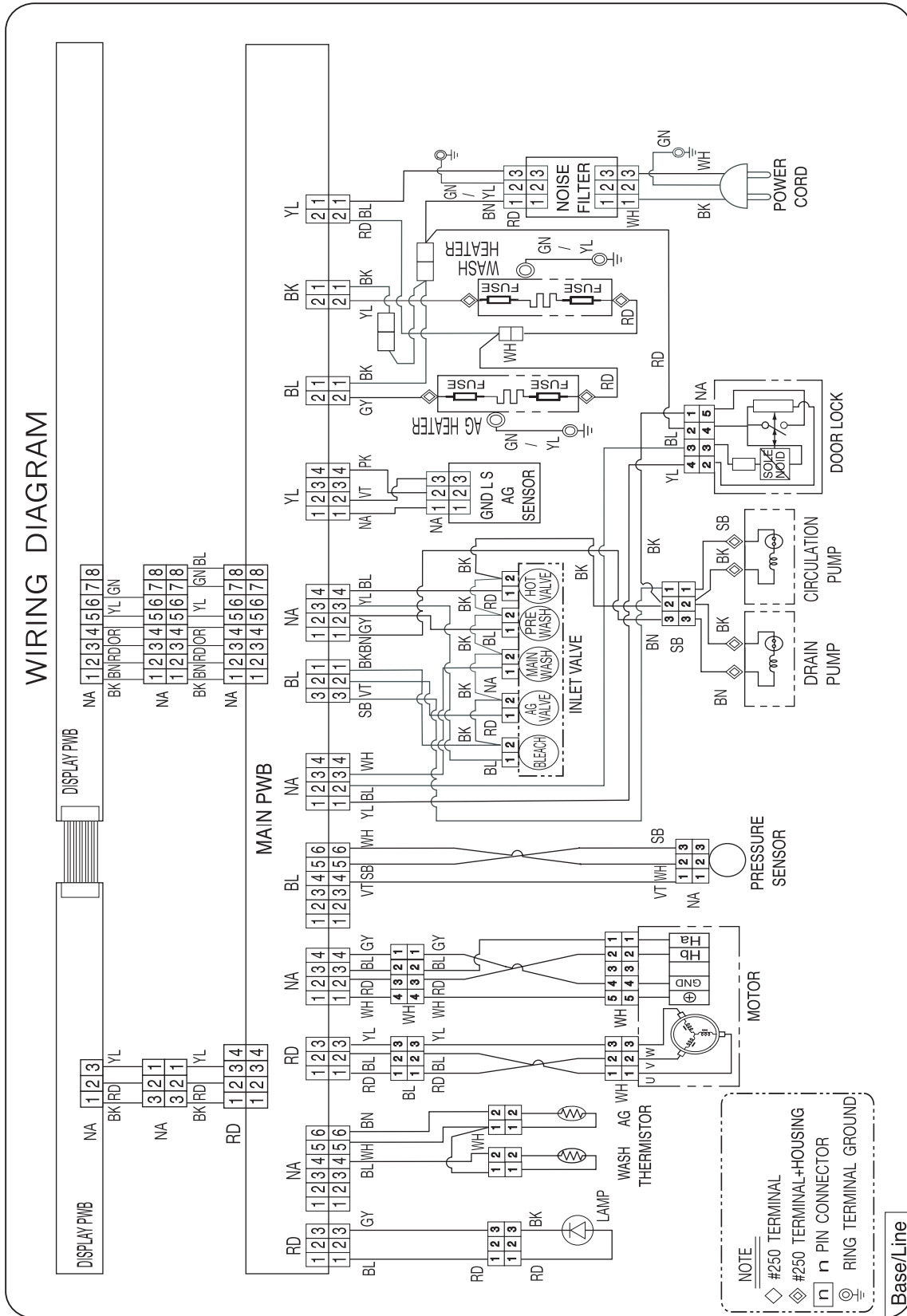

7. TEST MODE

7-1. SAFETY CAUTION

- There's built-in AC 120V and DC power in output terminal of PWB assembly in common. Be careful electric shock when disconnecting parts while trouble shooting. (Wear Electro Static Discharge gloves when working.)
- After cutting off the power when changing PWB assembly, disconnect or assemble.
- Be careful static when handling PWB assembly, and use Electro Static Discharge plastic pack when delivering or keeping it.

7-2. LOAD TEST MODE

The washer must be empty and the controls must be in the off state.

1. Press the WASH/RINSE and SPIN SPEED buttons simultaneously.
2. Press the Power (⏻) button, while the above condition. Then buzzer will sound twice.
3. Press the Start/Pause (⏸) button repeatedly to cycle through the test modes.

Number of times the Start/Pause button is pressed	Check Point	Display Status
None	Turns on all lamps and locks the door.	
1 time	Tumble clockwise.	rpm (42~50)
2 times	Low speed Spin.	rpm (55~65)
3 times	High speed Spin.	rpm (125~135)
4 times	Inlet valve for prewash turns on.	Water level frequency (25~65)
5 times	Inlet valve for main wash turns on.	Water level frequency (25~65)
6 times	Inlet valve for hot water turns on.	Water level frequency (25~65)
7 times	Inlet valve for steam turns on.	Water level frequency (25~65)
8 times	Inlet valve for bleach turns on.	Water level frequency (25~65)
9 times	Tumble counterclockwise.	rpm (42~50)
10 times	Heater turns on for 3 sec.	Water temperature
11 times	Circulation pump turns on.	Water level frequency (25~65)
12 times	Drain pump turns on.	Water level frequency (25~65)
13 times	Water level Sensor for Steam	Water level frequency of TSG(0~255)
14 times	Steam Heater turns on for 1.2 sec.	TSG temperature
15 times	Off	-

7-3. HOW TO CHECK THE WATER LEVEL FREQUENCY

* Press the CUSTOM and PRE-WASH buttons simultaneously.

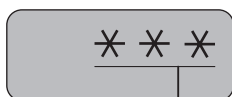

● The digits indicate the water level frequency.

For example, if the display indicate 41,
the water level frequency is $20+(41 \times 0.1) = 24.1$ kHz.

8. TROUBLESHOOTING



8-1. SAFETY CAUTION

- There's built-in AC 120V and DC power in output terminal of PWB assembly in common. Be careful electric shock when disconnecting parts while trouble shooting. (Wear Electro Static Discharge gloves when working.)
- After cutting off the power when changing PWB assembly, disconnect or assemble.
- Be careful static when handling PWB assembly, and use Electro Static Discharge plastic pack when delivering or keeping it.

8-2.ERROR MODE SUMMERY

- If you press the START/PAUSE button when an error is displayed, any error except **FE** will disappear and the machine will go into the pause status.
- In case of **FE**, **EE**, **DE** if the error is not resolved within 20 seconds, or the in case of other errors, if the error is not resolved within 4 minutes, power will be turned off automatically and the error code will blink. But in the case of **FE**, power will not be turned off.

	ERROR	SYMPTOM	CAUSE
1	WATER INLET ERROR	IE	<ul style="list-style-type: none"> • Correct water level (246) is not reached within 8 minutes after water is supplied or it does not reach the preset water level within 25 minutes.
2	IMBALANCE ERROR	LE	<ul style="list-style-type: none"> • The load is too small. • The appliance is tilted. • Laundry is gathered to one side. • Non distributable things are put into the drum.
3	DRAIN ERROR	DE	<ul style="list-style-type: none"> • Not fully drained within 10 minutes.
4	OVER FLOW ERROR	FE	<ul style="list-style-type: none"> • Water is overflowing (water level frequency is over 213). ※ If FE is displayed, the drain pump will operate to drain the water automatically.
5	PRESSURE SENEOR ERROR	PE	<ul style="list-style-type: none"> • The SENSOR SWITCH ASSEMBLY is out of order.
6	DOOR OPEN ERROR	DE	<ul style="list-style-type: none"> • Door not all the way closed. • Loose electrical connections at Door switch and PWB Assembly. • The DOOR SWITCH ASSEMBLY is out of order.
7	HEATING ERROR	EE	<ul style="list-style-type: none"> • The THERMISTOR is out order.

	ERROR	SYMPTOM	CAUSE
8	LOCKED MOTOR ERROR		<ul style="list-style-type: none"> • The connector (3-pin, male, white) in the MOTOR HARNESS is not connected to the connector (3-pin, female, white) of STATOR ASSEMBLY. • The electric contact between the connectors (3-pin, male, white) in the MOTOR HARNESS and 4-pin, female, white connector in the MAIN PWB ASSEMBLY is bad or unstable. • The MOTOR HARNESS between the STATOR ASSEMBLY and MAIN PWB ASSEMBLY is cut (open circuited). • The hall sensor is out of order/defective.
9	EEPROM ERROR		<ul style="list-style-type: none"> • EEPROM is out of order. ※ Displayed only when the START/PAUSE button is first pressed in the Load Test Mode.
10	POWER FAILURE		<ul style="list-style-type: none"> • After the power supply is stopped while washing machine is working, the power is supplied rapidly

8-3. TROUBLESHOOTING SUMMARY

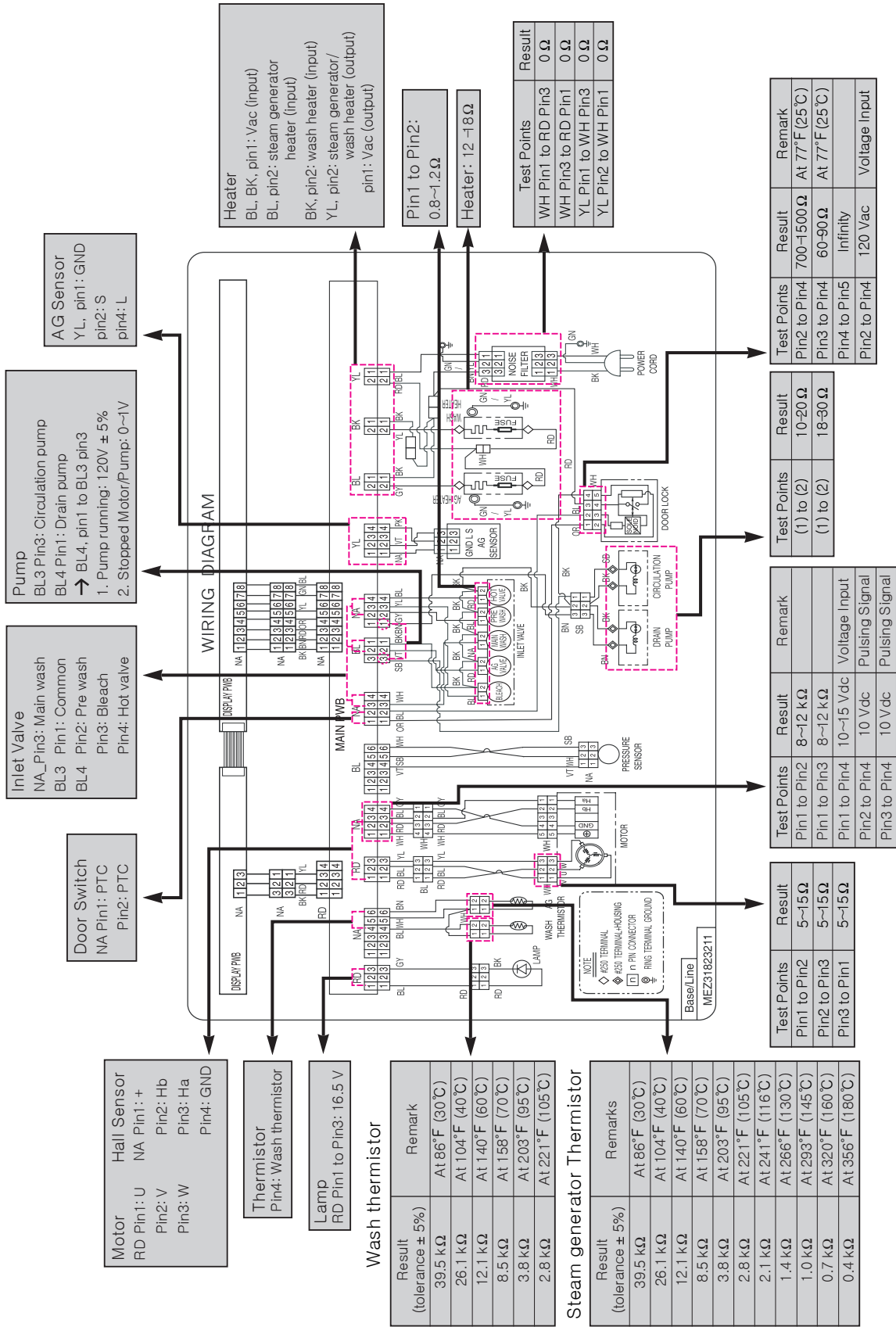

8-4. TROUBLESHOOTING WITH ERROR

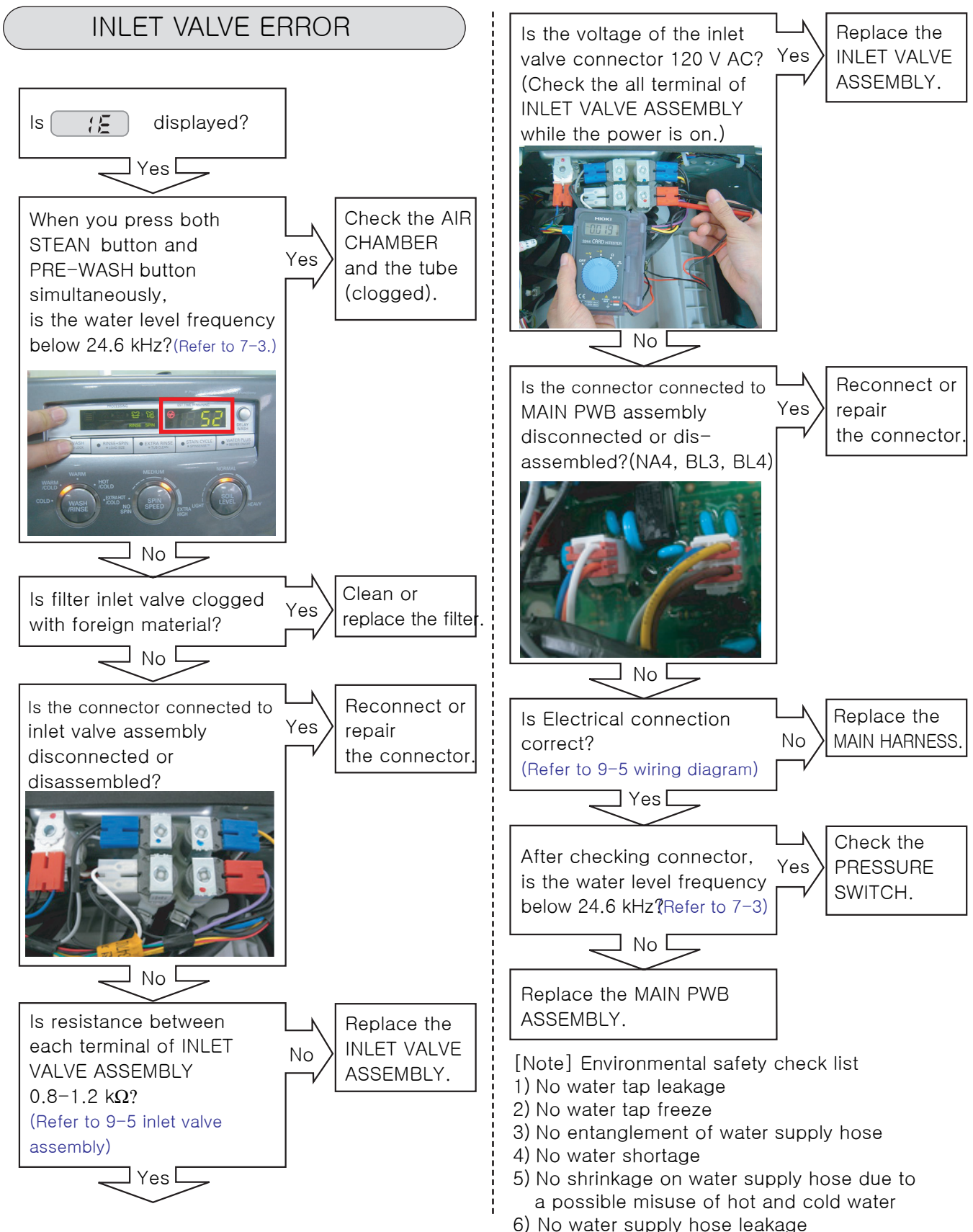

DRAIN ERROR

Is **DE** displayed?

Yes

Is the connector connected to pump motor assembly disconnected or disassembled?

Yes

Reconnect or repair the connector.



Circulation pump



Drain pump

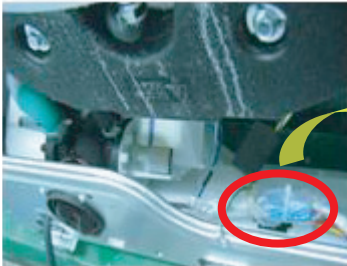

Connection connector



No

When you press both WASH/RINSE button and STEAM button simultaneously, is the water level frequency below 26.0 kHz?
(Refer to 7-3)

Yes

Check the AIR CHAMBER, the tube (clogged), and press switch



No

Is the coil of the drain pump too high or low? (resistance of the coil is 10~20Ω)
(Refer to 9-4 Pump motor assembly)

Yes

Replace the DRAIN PUMP ASSEMBLY.

No

Is the voltage between connectors out of range? (NA pin1~ BL3 pin1)
- After remove Terminal Position Assurance (TPA) of connector, check as follows.

Yes

Replace the MAIN PWB ASSEMBLY.

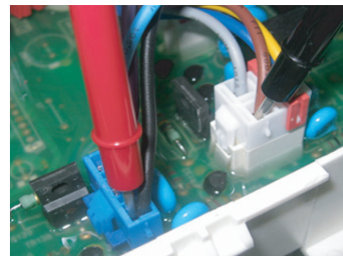

- Pump running : 120V±5%
- Stopped Motor/Pump : 0~Method
- 1. Press the Power button, while the SPIN SPEED button and SOIL LEVEL button is pressed simultaneously.
- 2. Press Start/Pause button.
 - : 1 time → Pump slow-speed running
 - : 2 times → Pump mid-speed running
 - : 3 times → Pump high-speed running
 - : 4 times → Stop the Motor/Pump

[Note] Environmental check list

- 1) The drainage hose must not stay in a lower position.
- 2) The drainage hose must not be bent or clogged in any way due to the surrounding physical configuration.
- 3) The drainage hose must not get frozen at all times.
- 4) The drainage pump must not have any improper substance or material inside that may cause a machine breakdown.

HEATING ERROR

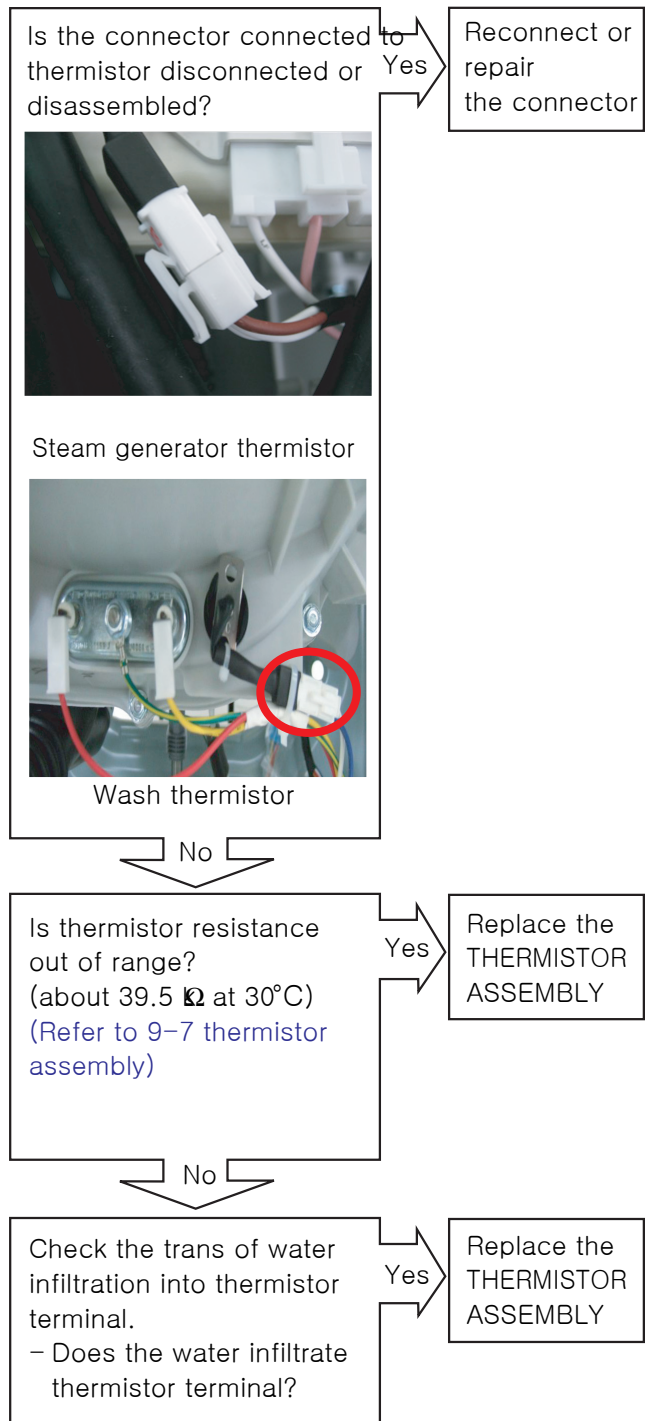
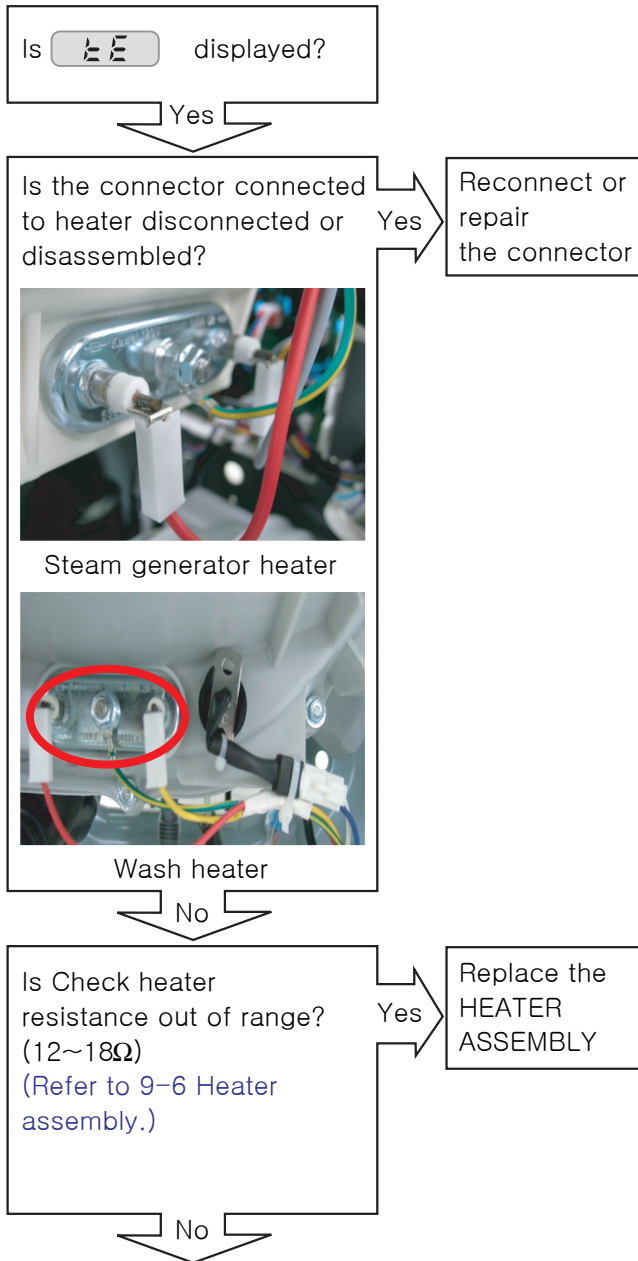

[Note]

Chances that the cause occurs from the main controller are very little.
Sensing part of the circuit (tE) consists of only resistors and capacitors.

LOCKED MOTOR ERROR

Is **LE** displayed?

Yes

Check the connectors below.
Is the connector disconnected or disassembled?
(motor hall sensor connector, motor drive connector)

- **part of main PWB assembly (RD4, NA1)**

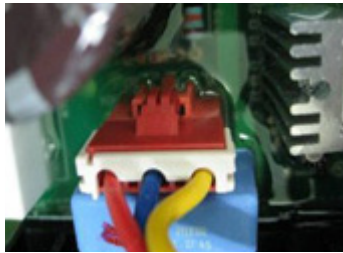

Motor Drive (RD4)



Hall sensor (NA1)

- **part of wire**

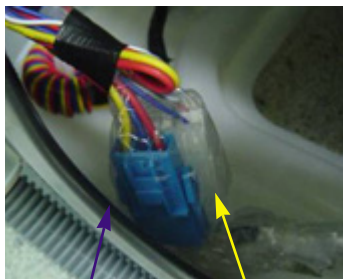

Motor Drive Hall Sensor

Yes

Reconnect the connector.
(connector / wire / motor)

- **part of motor**



Motor

Yes

Is rotor magnet cracked?

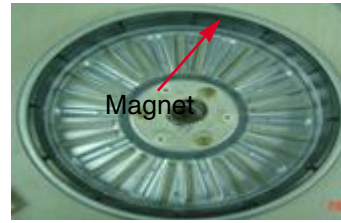

Magnet

Yes

Replace the ROTOR

No

Is the resistance values in the range of 5 to 15 Ω ?
(U-V, V-W, W-V)
:U=1, V=2, W=3)

- After pull out the RD4 connector, check the terminal of the connector in wire. (Red 3P, male)

No

Replace the STATOR



Yes

Is hall sensor out of order? (Refer to 9-3 Stator assembly/Hall sensor.)

Yes

Replace the Hall sensor

No

Check the IPM in the controller.

No

Replace the MAIN PWB ASSEMBLY

DOOR OPEN ERROR

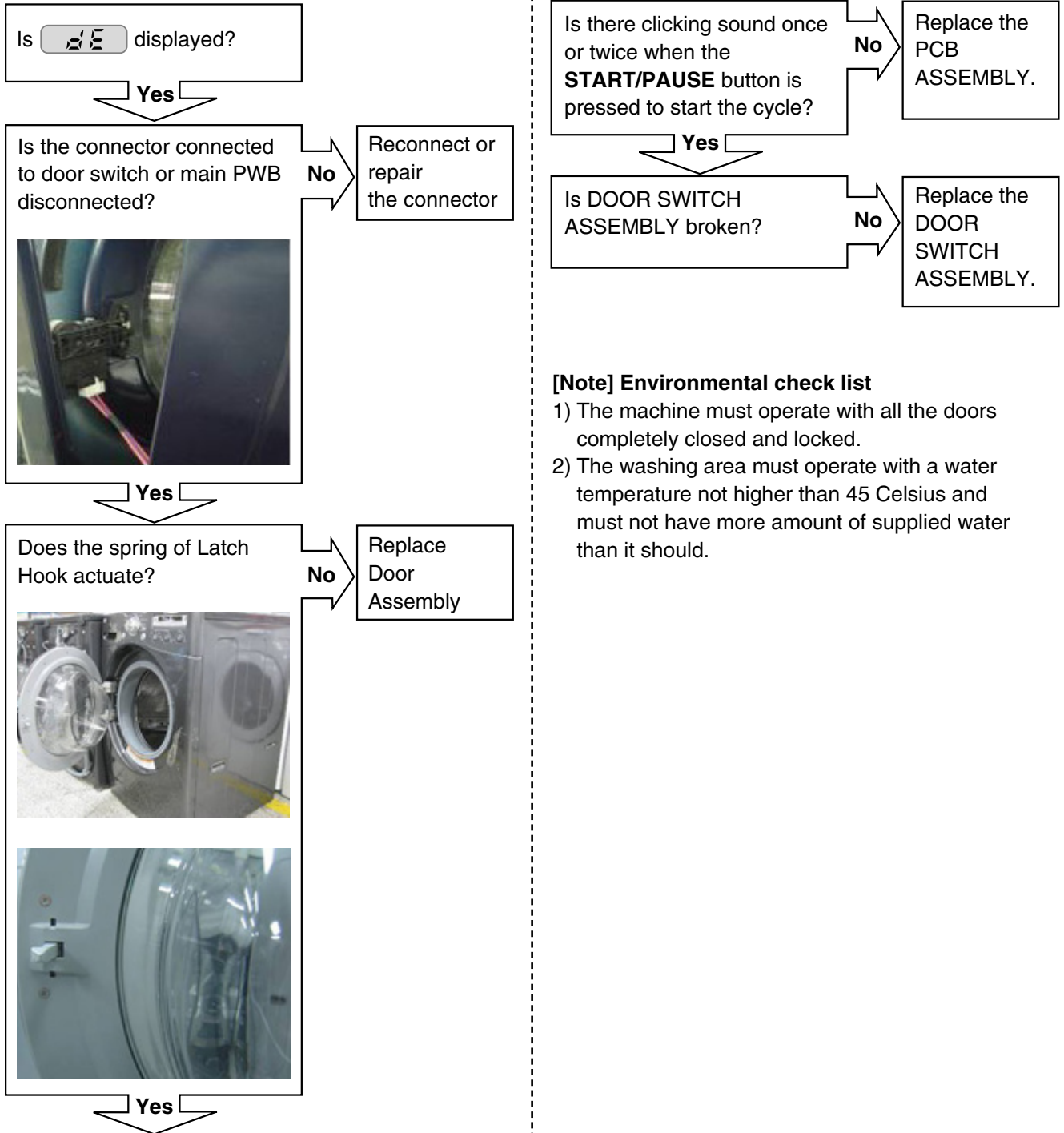

[Note] Environmental check list

- 1) The machine must operate with all the doors completely closed and locked.
- 2) The washing area must operate with a water temperature not higher than 45 Celsius and must not have more amount of supplied water than it should.

UNBALANCE ERROR

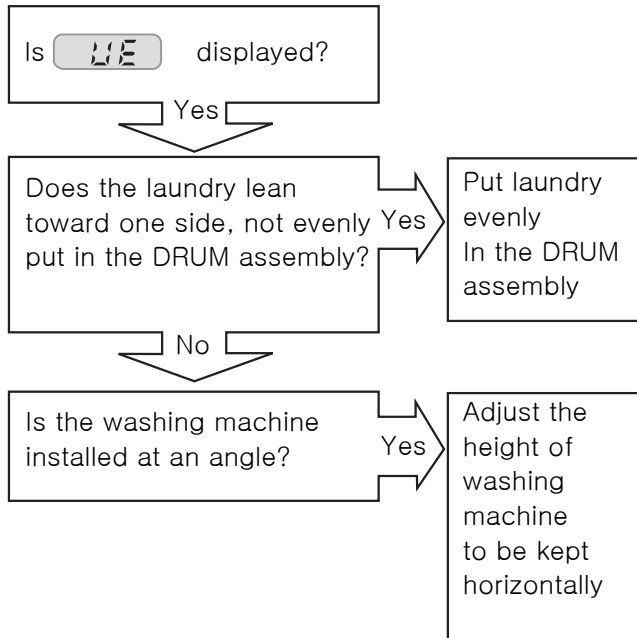

OVER FLOW ERROR

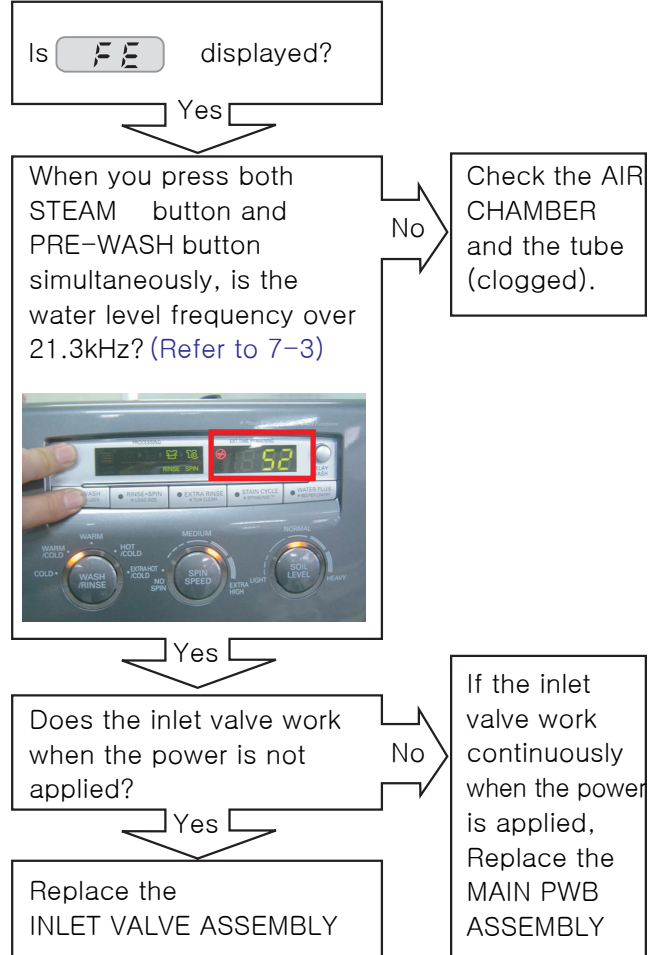

[Note] Environmental check list

- 1) Removal of transportation-based fixed bolt.
- 2) Confirmation on the material to see if it is capable of handling two different types of blanket materials.

PRESSURE SENSOR ERROR

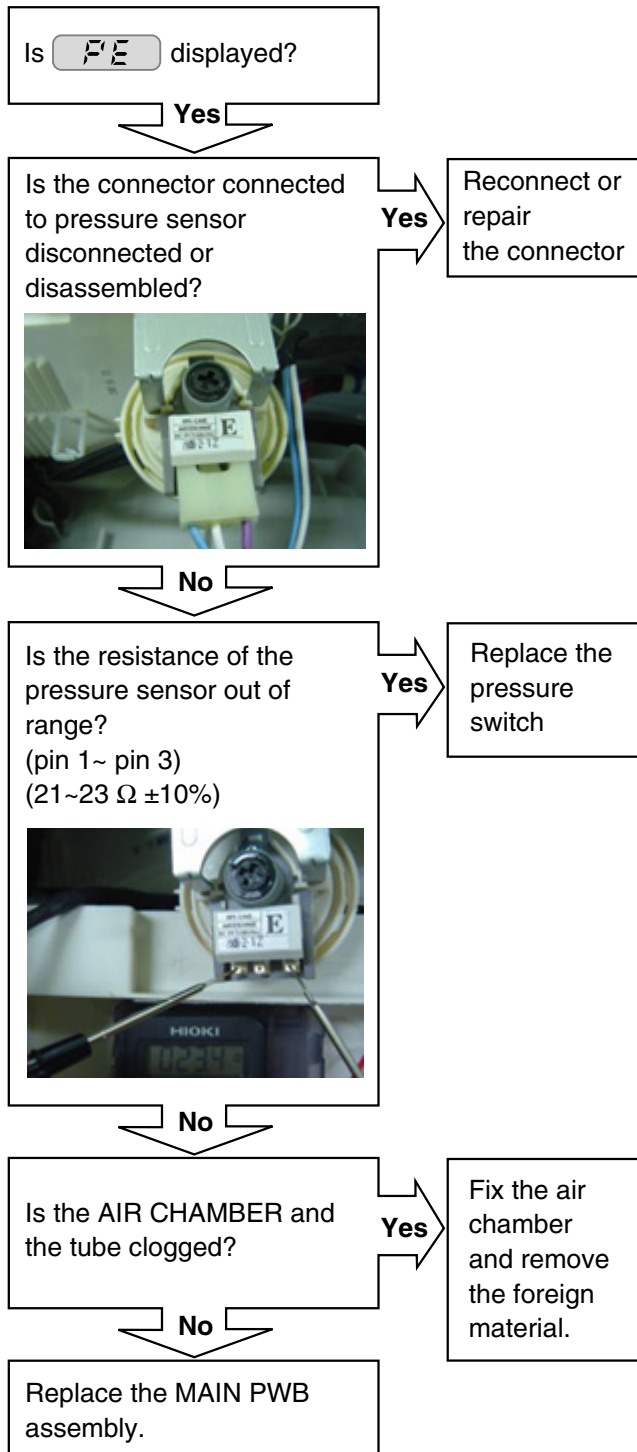

8-5. TROUBLESHOOTING ELSE

⚠ CAUTION

1. Be careful of electric shock if disconnecting parts while troubleshooting.
2. First of all, check the connection of each electrical terminal with the wiring diagram.
3. If you replace the MAIN PWB ASSEMBLY, reinsert the connectors correctly.

NO POWER

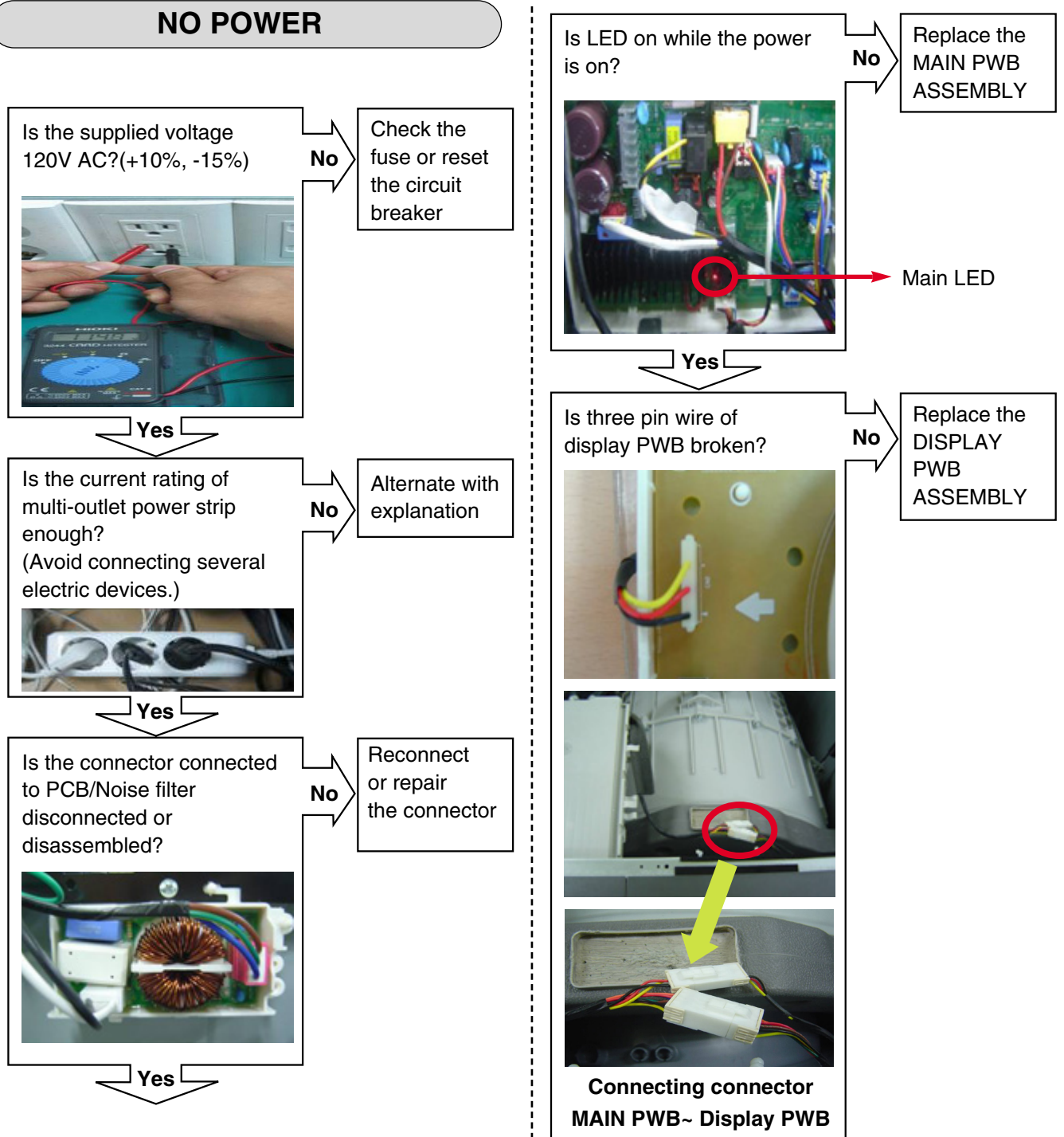

BUTTON DOESN'T WORK

Is the connector connected to Main PWB / Display PWB disconnected or disassembled?

Yes

Reconnect or Repair the connector

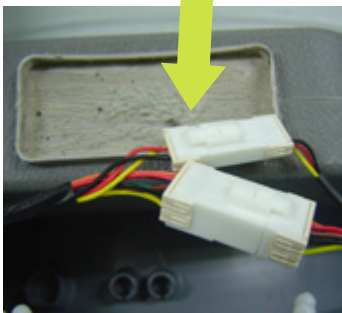

No

Is the button of panel stuck?

Yes

Repair the button



No

Is the display PCB broken? (check the buzzer sound and LED light while push the button.)

Yes

Replace the DISPLAY PWB ASSEMBLY



VIBRATION & NOISE IN SPIN

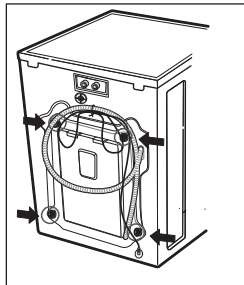

Have all the transit bolts and base packing been removed?

NO

Remove the transit bolts and Base packing.

YES

Is the washer installed on a solidly constructed floor?

NO

Move the washer or reinforce the floor.

YES

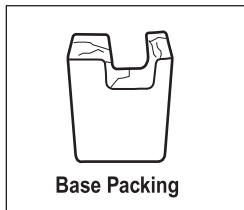

Check if the washer is perfectly level as follows:

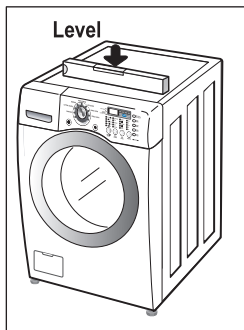

Check the leveling of the washer with a Level and check that the washer is stable.

Put an unbalance part (rubber) inside of drum and start QC test mode and run in high spin (Refer to section 7-2).
When the machine is spinning in high speed, verify that it is stable.

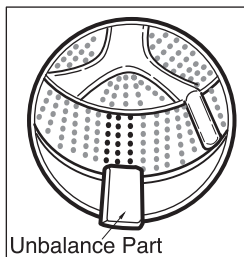

If you do not have the unbalance part, put 4.5 to 6.5 lbs (2 to 3 kg) of clothing. Once loaded, press power, Rinse+Spin and the start/pause button in sequence.
When the machine is spinning in high speed, verify that it is stable.

YES

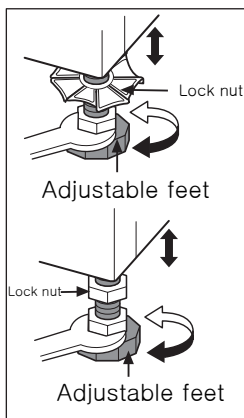

If it is not stable, adjust feet accordingly. After the washer is level, tighten the lock nuts up against of the base of the washer. All lock nuts must be tightened.

DETERGENT DOES NOT FLOW IN

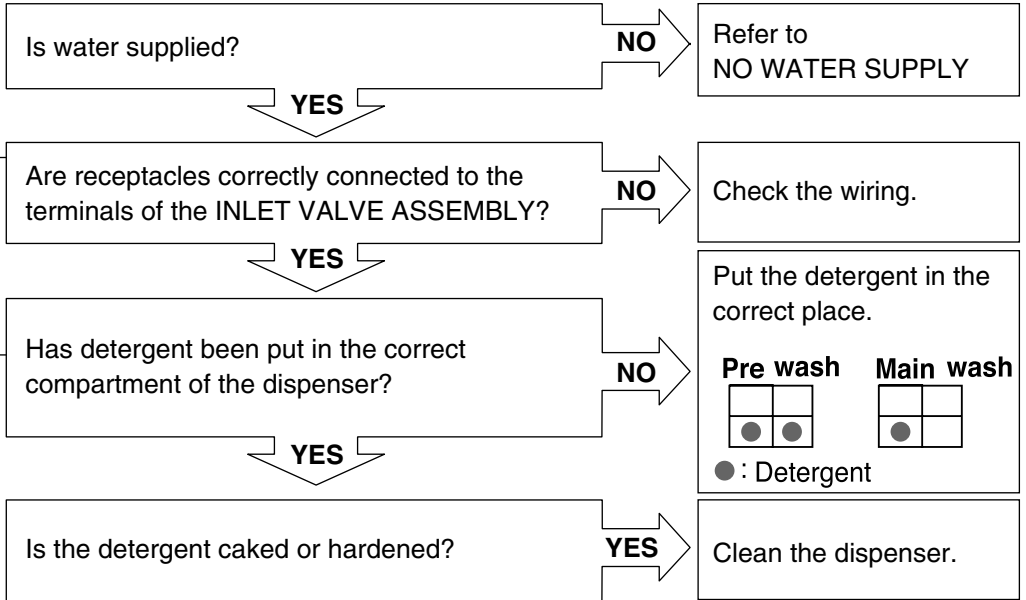
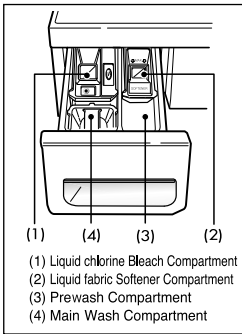
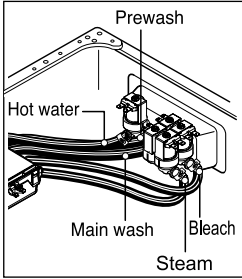

Put the detergent in the correct place.

Pre wash	Main wash				
<table border="1" style="width: 100%; height: 20px;"> <tr> <td style="width: 50%; height: 10px;">●</td> <td style="width: 50%; height: 10px;">●</td> </tr> </table>	●	●	<table border="1" style="width: 100%; height: 20px;"> <tr> <td style="width: 50%; height: 10px;">●</td> <td style="width: 50%; height: 10px;"></td> </tr> </table>	●	
●	●				
●					

● : Detergent

LIQUID DETERGENT/SOFTENER/BLEACH DOES NOT FLOW IN

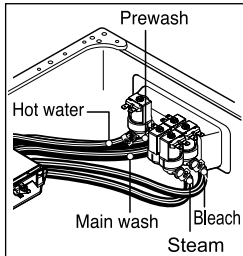

Is water supplied?

NO

Refer to
NO WATER SUPPLY

YES

Are the plugs correctly connected to the terminals of the INLET VALVE ASSEMBLY?

NO

Check the wiring on the dispenser.

YES

Is liquid detergent/softener/bleach put in the correct compartment of the drawer?

NO

Put it in the correct compartment.

YES

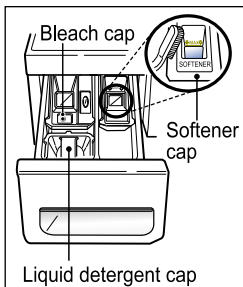
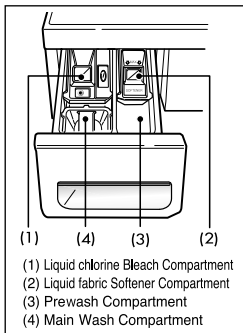

Is the liquid detergent/softener/bleach cap clogged?

YES

Clean the cap and Container.

ABNORMAL SOUND

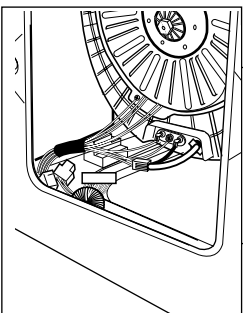

Is the motor bolt loosened?

YES

Secure the bolt.

NO

Is there friction noise coming from the motor?

YES

Check hall sensor.
Replace If defective.
Then check stator.
Replace if necessary.
Check rotor for broken magnets.
Replace rotor if necessary.

9. COMPONENT TESTING INFORMATION

▲ WARNING When Resistance (Ohm) checking the Component, be sure to turn the power off, and do voltage discharge sufficiently.

9-1. FILTER ASSEMBLY (LINE FILTER)

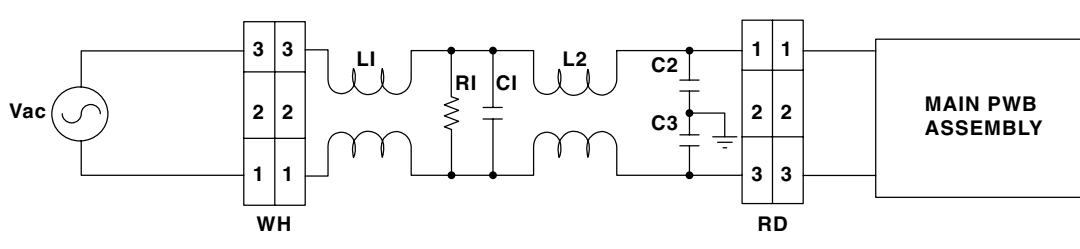
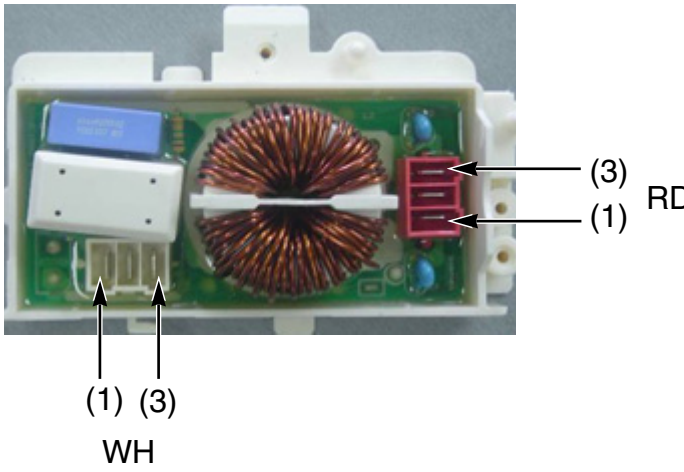
<p>Wiring diagram</p>	<p style="text-align: center;">Circuit in the MAIN PWB / Wiring Diagram</p> 						
<p>Test points and Result</p>	 <table border="1" data-bbox="641 1550 1118 1706"> <thead> <tr> <th>Test Points</th> <th>Result</th> </tr> </thead> <tbody> <tr> <td>WH (1) to RD (3)</td> <td>0 Ω</td> </tr> <tr> <td>WH (3) to RD (1)</td> <td>0 Ω</td> </tr> </tbody> </table>	Test Points	Result	WH (1) to RD (3)	0 Ω	WH (3) to RD (1)	0 Ω
Test Points	Result						
WH (1) to RD (3)	0 Ω						
WH (3) to RD (1)	0 Ω						

9-2. DOOR LOCK SWITCH ASSEMBLY

<p>Wiring diagram</p>	<p style="text-align: center;">Circuit in the MAIN PWB / Wiring Diagram</p>
<p>Function</p>	<p>The Door Lock Switch Assembly consists of a Heating PTC, a Bimetal, a Protection PTC, and a Solenoid. It locks the door during a wash cycle.</p> <ol style="list-style-type: none"> 1. Operation for door closing <ul style="list-style-type: none"> - After the system turns on, PTC heating starts up through terminal 2~4's authorizing the power on. - After PTC heating starts up and before solenoid operation is driven, force the system to the off position through CAM. ⇒ Door close - Authorizing one impulse through terminal 3~4 (PTC & solenoid) will make the door locked. - Door lock is detected when switches in terminal 4~5 are set closed. ⇒ CAM rotation will forcibly clear off the connection. <li style="padding-left: 20px;">The maximum, allowable number of impulse authorizations is 2. ⇒ Upon the third authorization of the impulse, the position of CAM goes back to the door-open position. - Authorizing the impulse occurs in 4.5 seconds upon input for max performance and two authorization processes are allowed at most. ⇒ Normal operation period of PTC heating: 1.5 – 5 seconds. (Defects from the development process.) 2. Operation for door opening <ul style="list-style-type: none"> - With a temporary stop, door automatically opens by CAM rotations after authorizing the impulse from the terminal 3 ~ 4 and the power turns off – maximum of 3 times of the authorizing period. - Upon the fourth authorization of the impulse, the position of CAM goes back to the door-close position.

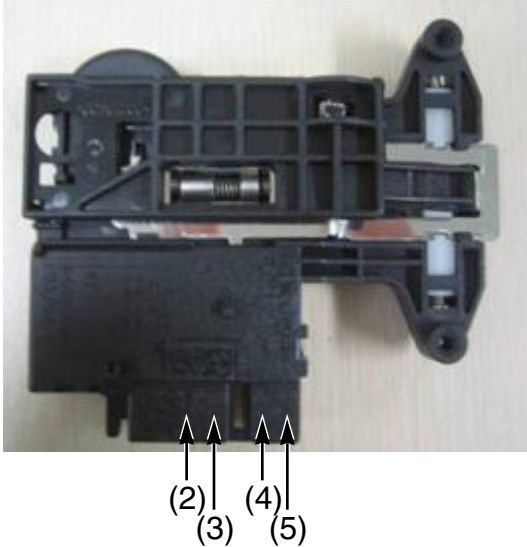
<p>Test points</p>																
<p>Result</p>	<table border="1"> <thead> <tr> <th>Test Points</th> <th>Result</th> <th>Remarks</th> </tr> </thead> <tbody> <tr> <td>(2) to (4)</td> <td>700-1500 Ω</td> <td>At 77°F (25°C)</td> </tr> <tr> <td>(3) to (4)</td> <td>60-90 Ω</td> <td>At 77°F (25°C)</td> </tr> <tr> <td>(4) to (5)</td> <td>Infinity</td> <td></td> </tr> <tr> <td>(2) to (4)</td> <td>120 Vac</td> <td>Voltage Input</td> </tr> </tbody> </table>	Test Points	Result	Remarks	(2) to (4)	700-1500 Ω	At 77°F (25°C)	(3) to (4)	60-90 Ω	At 77°F (25°C)	(4) to (5)	Infinity		(2) to (4)	120 Vac	Voltage Input
Test Points	Result	Remarks														
(2) to (4)	700-1500 Ω	At 77°F (25°C)														
(3) to (4)	60-90 Ω	At 77°F (25°C)														
(4) to (5)	Infinity															
(2) to (4)	120 Vac	Voltage Input														

9-3. STATOR ASSEMBLY

<p>Wiring diagram</p>	<p style="text-align: center;">Circuit in the MAIN PWB / Wiring Diagram</p>								
<p>Function</p>	<p>The DD motor can be driven from stopped to maximum speed in infinite steps in either direction.</p> <p>There are 36 poles on the stator; 12 permanent magnets spaced around the rotor. There are no brushes to wear out. Unlike a more traditional brushless motor, the rotor surrounds the stator rather than being attached to it.</p>								
<p>Test points (Windings)</p>	<p style="text-align: center;">HALL SENSOR</p> <p style="text-align: right;">WINDINGS</p> <p style="text-align: right;">(1) (2) (3)</p>								
<p>Result (Windings)</p>	<table border="1" style="margin-left: auto; margin-right: auto;"> <thead> <tr> <th>Test Points</th> <th>Result</th> </tr> </thead> <tbody> <tr> <td>(1) to (2)</td> <td>5-15 Ω</td> </tr> <tr> <td>(2) to (3)</td> <td>5-15 Ω</td> </tr> <tr> <td>(3) to (1)</td> <td>5-15 Ω</td> </tr> </tbody> </table>	Test Points	Result	(1) to (2)	5-15 Ω	(2) to (3)	5-15 Ω	(3) to (1)	5-15 Ω
Test Points	Result								
(1) to (2)	5-15 Ω								
(2) to (3)	5-15 Ω								
(3) to (1)	5-15 Ω								

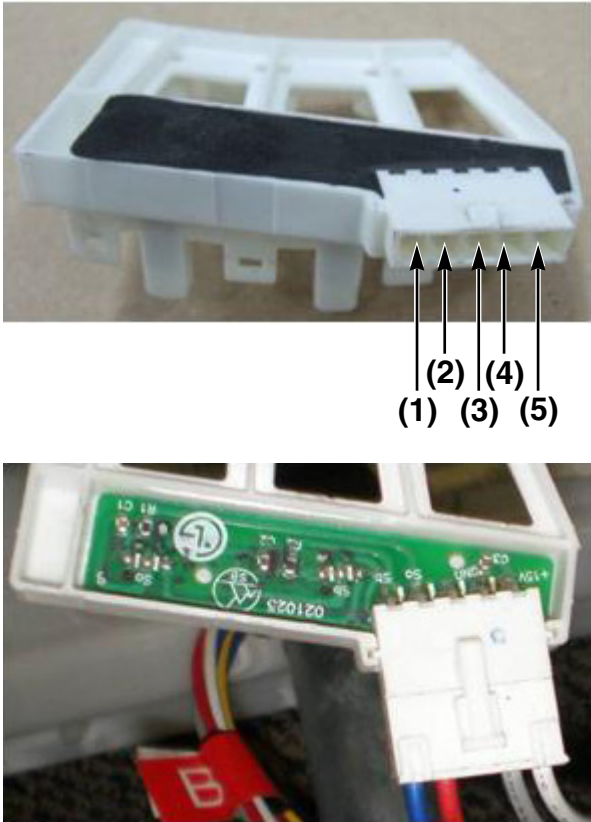
	<p>The hall sensor determines the speed and direction of the motor. It also can read that the load is off balance when the drum speed fluctuates.</p>
<p>Test point and Result (Hall Sensor)</p>	<p>- Voltage Testing Hall Sensor at Stator</p>  <p>If measuring voltage from the Main PCB Assembly to the Hall Sensor, use the following steps:</p> <ol style="list-style-type: none"> 1. Unplug power cord. 2. Remove rear washer panel. 3. Locate Hall sensor connector on the stator behind the rotor. 4. Place meter leads on terminals 5 to 4, white to gray. 5. Plug in power cord, close door, and press power button. DO NOT PRESS START! 6. You should measure 10 to 15 Vdc. If 10 to 15 Vdc is present, control board, white wire, and gray wire are OK! If not follow testing output voltages on control board in next section.

7. To measure output signal voltage from the hall sensor, carefully move test leads to terminals 1 to 4, blue and gray. Slowly rotate motor rotor by hand. You should read a pulsing 10 Vdc. If 10 Vdc is measured from 1 to 4, move lead on blue wire to red wire, terminal 2. Repeat rotating motor rotor by hand. You should read a pulsing 10 Vdc from red to gray.
8. If pulsing 10 Vdc is measured from 1 to 4 and 2 to 4, hall sensor is OK! If either test netted only 9 to 10 Vdc without changing (no pulsing) the hall sensor is likely defective. Disconnect power by unplugging washer and ohm check hall sensor to verify failure of the hall sensor.

**Test Point
and
Result
(Hall
Sensor)**

- Voltage Testing Hall Sensor from the Main PCB Assembly

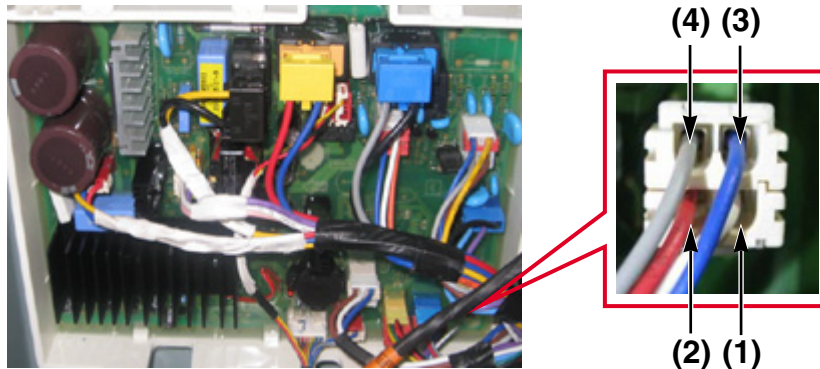

1. Unplug power cord.
2. Remove rear panel.
3. Remove Washer Top.
4. Remove Main PCB Assembly cover as shown in Figure below.
5. Locate the white Hall Sensor 4 wire connector using wiring diagram wire colors as your guide.
6. Plug in power cord, close door, and press power button. **DO NOT PRESS START!**
7. Place meter leads on White & Gray wires. You should read 10 to 15 Vdc output from the Main PCB Assembly to the Hall sensor. If no 10 to 15 Vdc is measured the control board is defective.
8. Place meters leads on Blue to Gray. Turn motor rotor slowly by hand. You should measure a pulsing 10 Vdc. Place meter leads on Red to Gray. Turn motor rotor slowly by hand. You should measure a pulsing 10 Vdc. If both tests measure a pulsing 10 Vdc, hall sensor and harness OK. If either or both tests measures 9 to 10 volts, but does not pulse or change, Hall sensor has failed and must be replaced. IF zero (0) voltage is measured on either test, check red & blue wires for continuity. Repair or replace harness as needed.

Test Points	Result	Remarks
(1) to (2)	8-12 kΩ	
(1) to (3)	8-12 kΩ	
(1) to (4)	10-15 Vdc	Voltage Input
(2) to (4)	10 Vdc	Pulsing Signal
(3) to (4)	10 Vdc	Pulsing Signal

9-4. PUMP MOTOR ASSEMBLY

<p>Wiring diagram</p>	<div style="display: flex; justify-content: space-around;"> <div style="border: 1px solid black; padding: 5px; width: 45%;"> <p style="text-align: center;">Circuit in the MAIN PWB</p> <p style="text-align: center;">Pump Driving circuit</p> </div> <div style="border: 1px solid black; padding: 5px; width: 45%;"> <p style="text-align: center;">Wiring Diagram</p> <p style="text-align: center;">DRAIN PUMP CIRCULATION PUMP</p> </div> </div> <p style="text-align: right; margin-top: 10px;">* Each circuits of loads in wiring diagram are all same.</p>													
<p>Object</p>	<p style="text-align: center;">For Drain For Circulation</p>													
<p>Function</p>	<p>Two pump motors are used to drain the tub and to circulate the water / detergent solution.</p>													
<p>Test points</p>	<div style="display: flex; justify-content: space-around;"> <div style="text-align: center;"> <p>Drain Pump</p> <p>(1)(2)</p> </div> <div style="text-align: center;"> <p>Circulation Pump</p> <p>(1)(2)</p> </div> <div style="text-align: center;"> <p>(1) (2)</p> </div> </div>													
<p>Result</p>	<table border="1" style="width: 100%; border-collapse: collapse;"> <thead> <tr> <th colspan="2" style="text-align: center;">Drain Pump</th> <th colspan="2" style="text-align: center;">Circulation Pump</th> </tr> <tr> <th style="width: 25%;">Test Points</th> <th style="width: 25%;">Result</th> <th style="width: 25%;">Test Points</th> <th style="width: 25%;">Result</th> </tr> </thead> <tbody> <tr> <td style="text-align: center;">(1) to (2)</td> <td style="text-align: center;">10-20 Ω</td> <td style="text-align: center;">(1) to (2)</td> <td style="text-align: center;">18-30 Ω</td> </tr> </tbody> </table>		Drain Pump		Circulation Pump		Test Points	Result	Test Points	Result	(1) to (2)	10-20 Ω	(1) to (2)	18-30 Ω
Drain Pump		Circulation Pump												
Test Points	Result	Test Points	Result											
(1) to (2)	10-20 Ω	(1) to (2)	18-30 Ω											

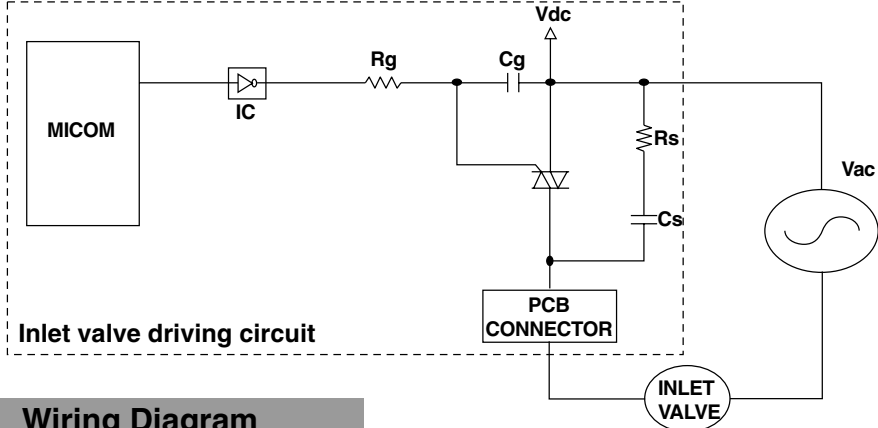
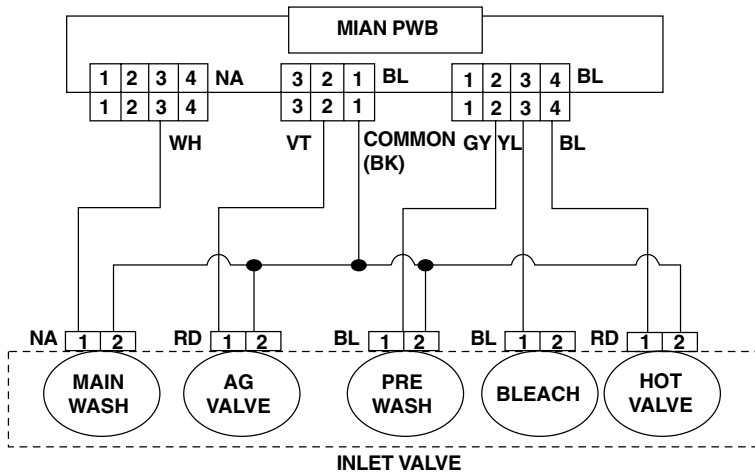
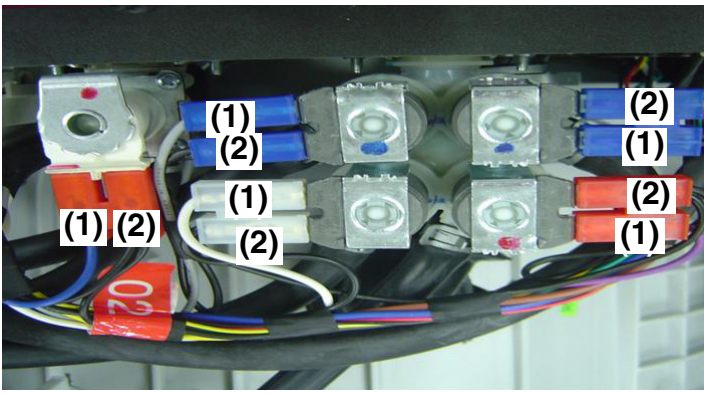

9-5. INLET VALVE ASSEMBLY

<p>Wiring diagram</p>	<div style="text-align: center; background-color: #cccccc; padding: 5px; margin-bottom: 10px;">Circuit in the MAIN PWB</div>  <div style="text-align: center; background-color: #cccccc; padding: 5px; margin-bottom: 10px;">Wiring Diagram</div>  <p style="text-align: center;">* Each circuits of loads in wiring diagram are all same.</p>				
<p>Function</p>	<p>Depending on the cycle and water temperature, the controller will energize the hot or cold water valve solenoids to meet the selected water temperature.</p>				
<p>Test points and Result</p>	<p>After pull out the connector of defective valve, check the resistance.</p>  <table border="1" style="float: right; margin-top: 10px;"> <tr> <td>Test points</td> <td>(1)-(2)</td> </tr> <tr> <td>Result</td> <td>0.8-1.2 kΩ</td> </tr> </table>	Test points	(1)-(2)	Result	0.8-1.2 kΩ
Test points	(1)-(2)				
Result	0.8-1.2 kΩ				

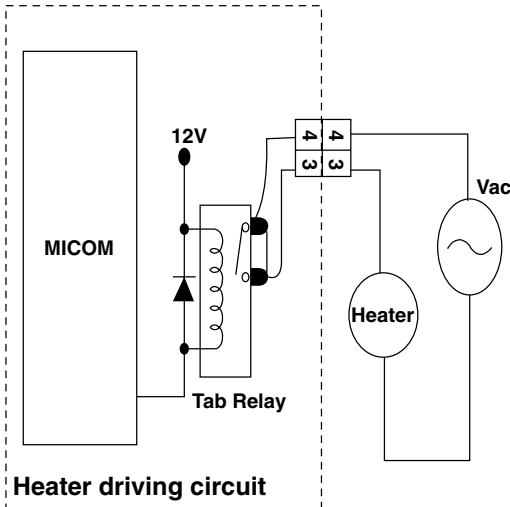
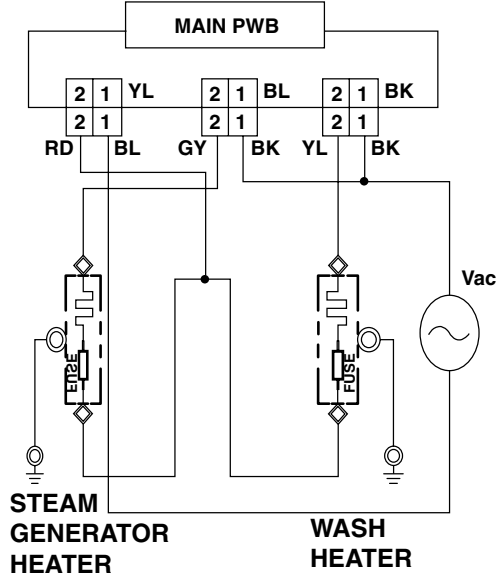
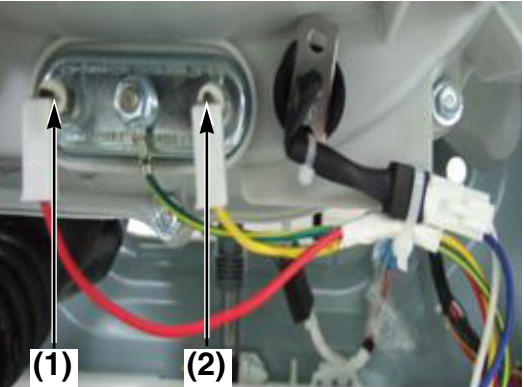
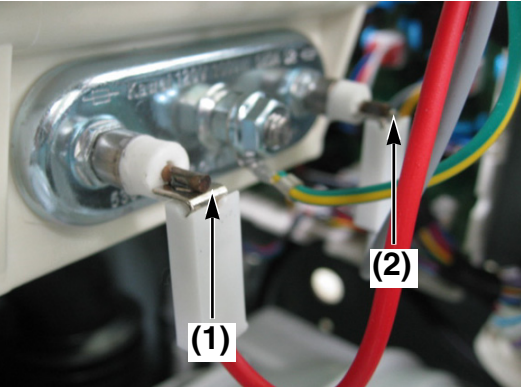
9-6. HEATER ASSEMBLY

<p>Wiring diagram</p>	<div style="display: flex; justify-content: space-around;"> <div style="border: 1px solid black; padding: 5px; width: 45%;"> <p style="text-align: center;">Circuit in the MAIN PWB</p>  <p style="text-align: center;">Heater driving circuit</p> </div> <div style="border: 1px solid black; padding: 5px; width: 45%;"> <p style="text-align: center;">Wiring diagram</p>  <p style="text-align: center;">STEAM GENERATOR HEATER WASH HEATER</p> </div> </div> <p style="text-align: right; margin-top: 10px;">* Each circuits of loads in wiring diagram are all same.</p>												
<p>Function</p>	<ol style="list-style-type: none"> 1. The Wash Heater is designed to raise the wash water to the desired temperature selection during certain wash cycles. 2. The Steam generator heater is designed to make the water to the steam during steam cycles. 												
<p>Test points</p>	<div style="display: flex; justify-content: space-around;"> <div style="text-align: center;">  <p>Wash Heater</p> </div> <div style="text-align: center;">  <p>Steam Generator Heater</p> </div> </div>												
<p>Result</p>	<table style="width: 100%; border-collapse: collapse;"> <thead> <tr> <th colspan="2" style="text-align: center; border: none;">Wash Heater</th> <th colspan="2" style="text-align: center; border: none;">Steam Generator Heater</th> </tr> <tr> <th style="border: 1px solid black; text-align: center;">Test Points</th> <th style="border: 1px solid black; text-align: center;">Result</th> <th style="border: 1px solid black; text-align: center;">Test Points</th> <th style="border: 1px solid black; text-align: center;">Result</th> </tr> </thead> <tbody> <tr> <td style="border: 1px solid black; text-align: center;">(1) to (2)</td> <td style="border: 1px solid black; text-align: center;">12-18 Ω</td> <td style="border: 1px solid black; text-align: center;">(1) to (2)</td> <td style="border: 1px solid black; text-align: center;">12-18 Ω</td> </tr> </tbody> </table>	Wash Heater		Steam Generator Heater		Test Points	Result	Test Points	Result	(1) to (2)	12-18 Ω	(1) to (2)	12-18 Ω
Wash Heater		Steam Generator Heater											
Test Points	Result	Test Points	Result										
(1) to (2)	12-18 Ω	(1) to (2)	12-18 Ω										

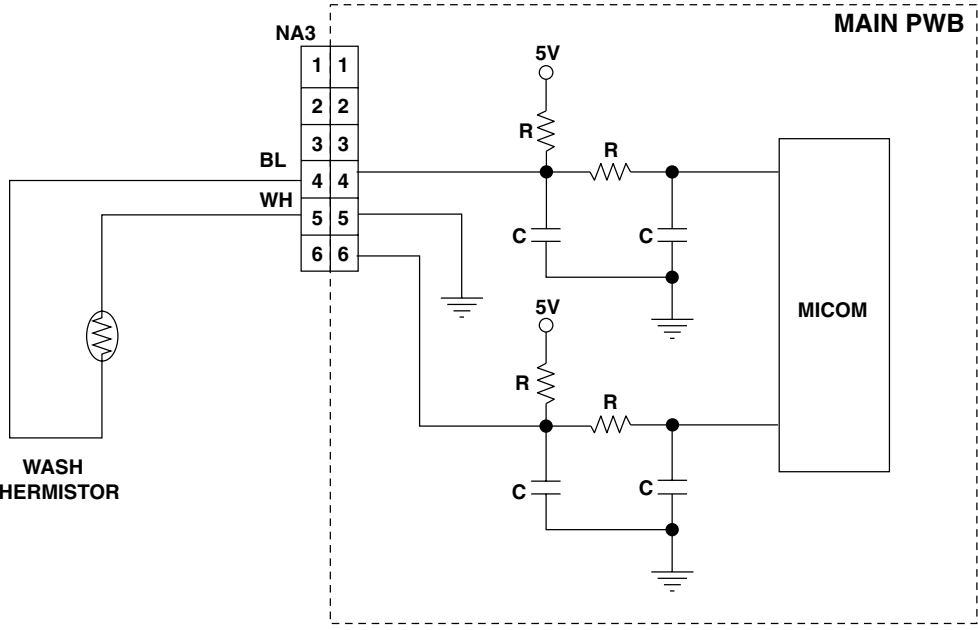
9-7. THERMISTOR ASSEMBLY

<p>Wiring diagram</p>	<p style="text-align: center;">Circuit in the MAIN PWB / Wiring Diagram</p> 																	
<p>Function</p>	<p>The thermistor (temperature sensor) is used to monitor water temperature in the tub or Steam Generator.</p>																	
<p>Test points & Result</p>	 <p style="text-align: center;">Wash Thermistor</p> <table border="1" data-bbox="957 1326 1492 1720"> <thead> <tr> <th>Test Points</th> <th>Result (tolerance $\pm 5\%$)</th> <th>Remarks</th> </tr> </thead> <tbody> <tr> <td rowspan="2">(1)</td> <td>39.5 kΩ</td> <td>At 86°F (30°C)</td> </tr> <tr> <td>26.1 kΩ</td> <td>At 104°F (40°C)</td> </tr> <tr> <td rowspan="4">(2)</td> <td>12.1 kΩ</td> <td>At 140°F (60°C)</td> </tr> <tr> <td>8.5 kΩ</td> <td>At 158°F (70°C)</td> </tr> <tr> <td>3.8 kΩ</td> <td>At 203°F (95°C)</td> </tr> <tr> <td>2.8 kΩ</td> <td>At 221°F (105°C)</td> </tr> </tbody> </table>	Test Points	Result (tolerance $\pm 5\%$)	Remarks	(1)	39.5 k Ω	At 86°F (30°C)	26.1 k Ω	At 104°F (40°C)	(2)	12.1 k Ω	At 140°F (60°C)	8.5 k Ω	At 158°F (70°C)	3.8 k Ω	At 203°F (95°C)	2.8 k Ω	At 221°F (105°C)
Test Points	Result (tolerance $\pm 5\%$)	Remarks																
(1)	39.5 k Ω	At 86°F (30°C)																
	26.1 k Ω	At 104°F (40°C)																
(2)	12.1 k Ω	At 140°F (60°C)																
	8.5 k Ω	At 158°F (70°C)																
	3.8 k Ω	At 203°F (95°C)																
	2.8 k Ω	At 221°F (105°C)																

Result	Wash Thermistor		
	Test Points	Result (tolerance $\pm 5\%$)	Remarks
	(1) to (2)	39.5 k Ω	At 86°F (30°C)
		26.1 k Ω	At 104°F (40°C)
		12.1 k Ω	At 140°F (60°C)
		8.5 k Ω	At 158°F (70°C)
		3.8 k Ω	At 203°F (95°C)
		2.8 k Ω	At 221°F (105°C)
	Steam generator Thermistor		
	Test Points	Result (tolerance $\pm 5\%$)	Remarks
	(1) to (2)	39.5 k Ω	At 86°F (30°C)
		26.1 k Ω	At 104°F (40°C)
		12.1 k Ω	At 140°F (60°C)
		8.5 k Ω	At 158°F (70°C)
		3.8 k Ω	At 203°F (95°C)
		2.8 k Ω	At 221°F (105°C)
		2.1 k Ω	At 241°F (116°C)
		1.4 k Ω	At 266°F (130°C)
		1.0 k Ω	At 293°F (145°C)
		0.7 k Ω	At 320°F (160°C)
		0.4 k Ω	At 356°F (180°C)

9-8. STEAM GENERATOR ASSEMBLY

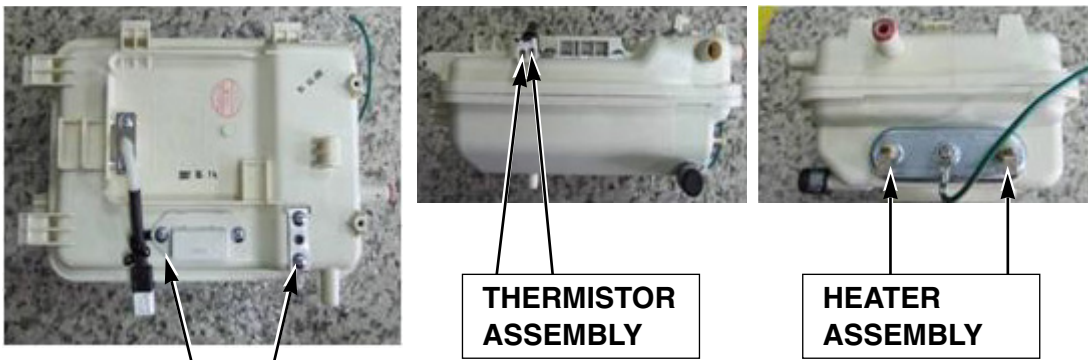
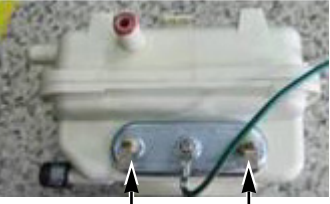
<p>Wiring diagram</p>	<p style="text-align: center;">Steam generator Water level sensor circuit in the MAIN PWB / wiring diagram</p> <p style="text-align: center;">Heater & Thermistor : Refer to the 9-6 / 9-7</p>
<p>Original</p>	<div style="display: flex; justify-content: space-around; align-items: center;"> <div style="text-align: center;">  <p>WATER LEVEL SENSOR</p> </div> <div style="text-align: center;">  <p>THERMISTOR ASSEMBLY</p> </div> <div style="text-align: center;">  <p>HEATER ASSEMBLY</p> </div> </div>
<p>Test points</p>	<p>1. Steam generator</p> <p>1) Construction of steam generator Inlet valve that controls supplying water, Water level sensor that sense amount of water supply, Thermistor ASSEMBLY the sense inner temperature of Steam generator, Heater ASSEMBLY that heats water supply, Steam generator CASE that is container of water supply, nozzle and hose of water supply.</p>

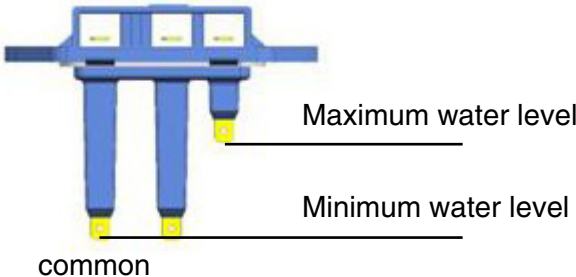
<p>Function</p>	<p>2) Operation mechanism of Steam generator After supplying some amount of water through inlet valve and water level sensor, Heater operates and steam generates. Generated steam is sprayed by nozzle. If the water in the steam generator is reduced by spraying steam, water level sensor decide to supply water or not.</p> <p>3) Operation method of Steam generator The Steam Generator Assembly is supplied as an assembly only; parts like the water level sensor, thermistor, or heater cannot be replaced individually. Diagnosis is limited to determining malfunction and replacing as an assembly. The steam generator does not have to be removed from the machine to be drained. Be sure to let the water cool to avoid a burn. Have a hose available to slip onto the connector or a large towel to catch the water so it doesn't run down into the machine cabinet. If you remove the steam generator before draining it, be sure to avoid tipping it and spilling the water.</p>
	<p>2. Water level sensor</p> <p>1) Structure of water level sensor</p>  <p>2) Function of Water level sensor It is the part of sensing water level. It decides to supply water or not when the steam generate. (to protect heater)</p>

9-9. LAMP

<p>Wiring diagram</p>	<p style="text-align: center;">Circuit in the MAIN PWB / Wiring Diagram</p>						
<p>Function</p>	<p>The Lamp (Drum Light) comes on when the POWER button is pressed. It goes off when the door is closed and the washer starts operation. It remains off when the door is locked. It can be turned on while the washer is in operation by pressing the RINSE+SPIN button for 3 seconds. The lamp will turn off automatically 4 minutes later. It comes on when the washing cycle is finished and goes off 4 minutes later.</p>						
<p>Test points</p>	<p style="text-align: center;">Original</p>						
<p>Result</p>	<table border="1" style="width: 100%; border-collapse: collapse;"> <thead> <tr> <th style="width: 33%;">Test Points</th> <th style="width: 33%;">Result</th> <th style="width: 33%;">Remarks</th> </tr> </thead> <tbody> <tr> <td>(3) to (1)</td> <td>16.5 Vdc</td> <td>Voltage Input</td> </tr> </tbody> </table>	Test Points	Result	Remarks	(3) to (1)	16.5 Vdc	Voltage Input
Test Points	Result	Remarks					
(3) to (1)	16.5 Vdc	Voltage Input					

10. DISASSEMBLY INSTRUCTIONS

* Be sure to unplug the machine before disassembling and repairing the parts.

CONTROL PANEL ASSEMBLY

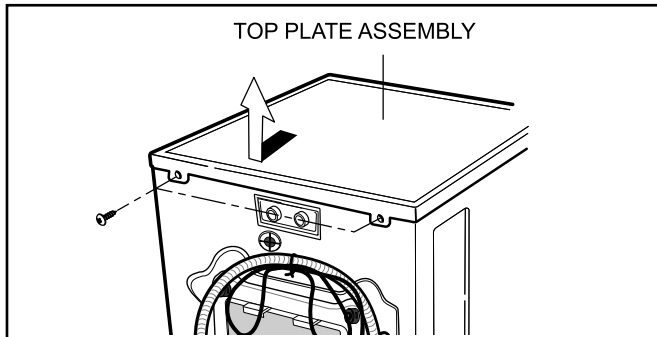

- ① Unscrew 2 screws on the back of the top plate.
- ② Pull the top plate backward and upward as shown.

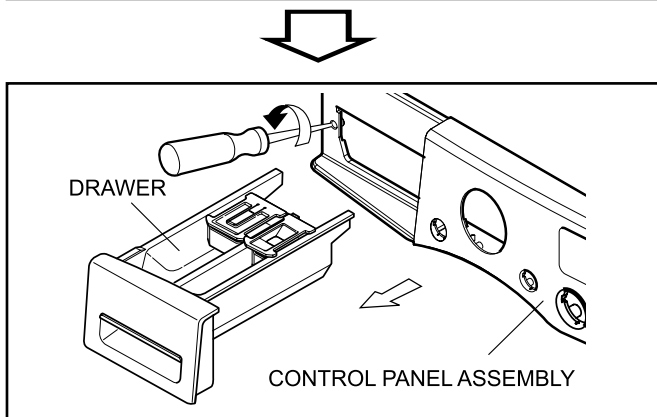

- ③ Disconnect the Display PWB assembly connector from trans cable.
- ④ Pull out the drawer and unscrew 2 screws.

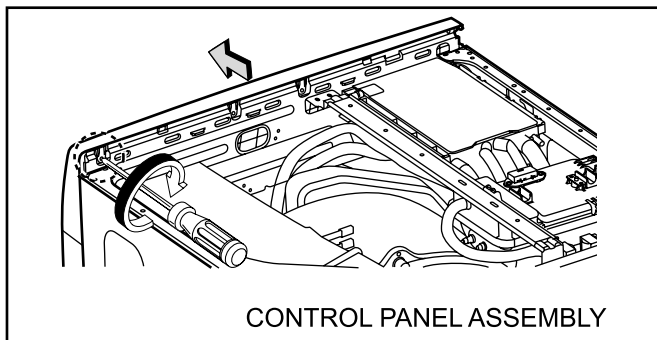

- ⑤ Remove one screw.
- ⑥ Lift the side the control panel assembly and pull it out

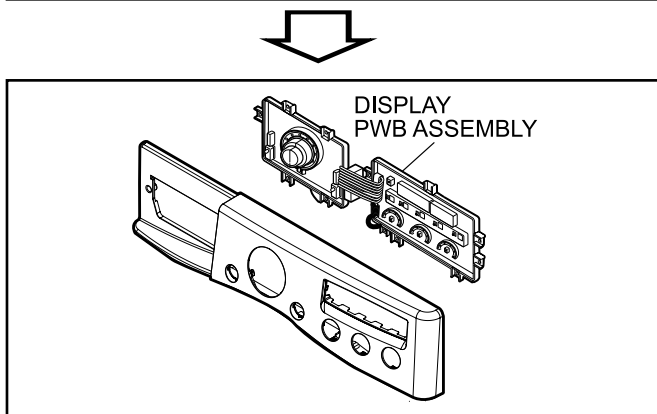

- ⑦ Unscrew the 8 screws from the control panel assembly.
- ⑧ Disassemble the Display PWB Assembly.

MAIN PWB ASSEMBLY

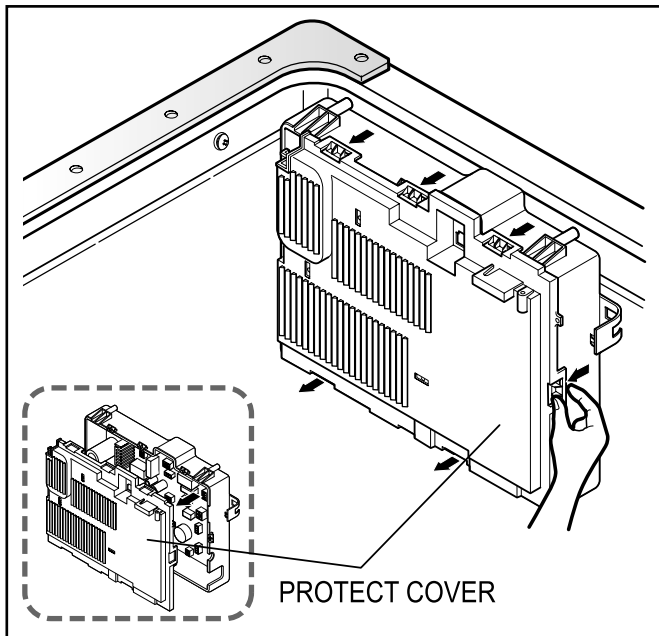

- ① Disconnect the POWER connector and SENSOR SWITCH ASSEMBLY.
- ② Remove the Protective cover.

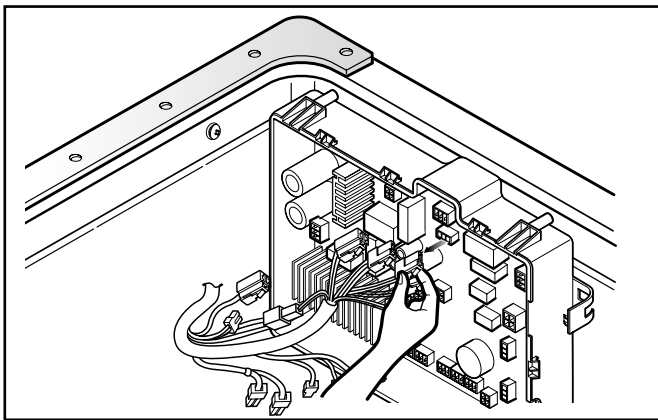

- ③ Disconnect the connectors.

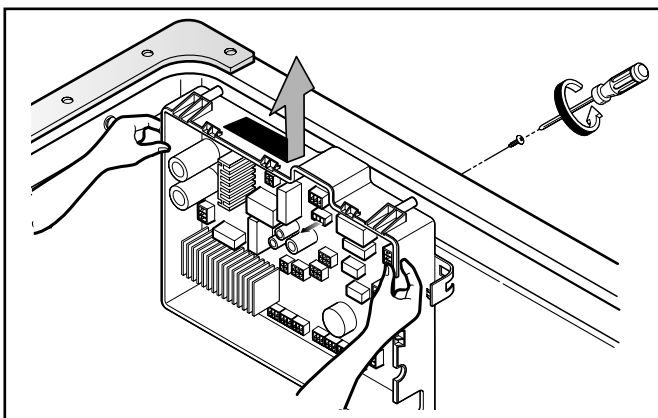

- ④ Unscrew 1 screw on the back.
- ⑤ Remove the Main PWB.

DISPENSER ASSEMBLY

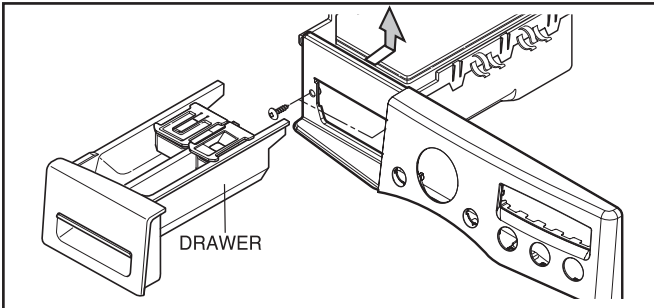

- ① Disassemble the top plate assembly.
- ② Pull out the drawer.
- ③ Push out the DISPENSER ASSEMBLY after unscrewing 2 screws.

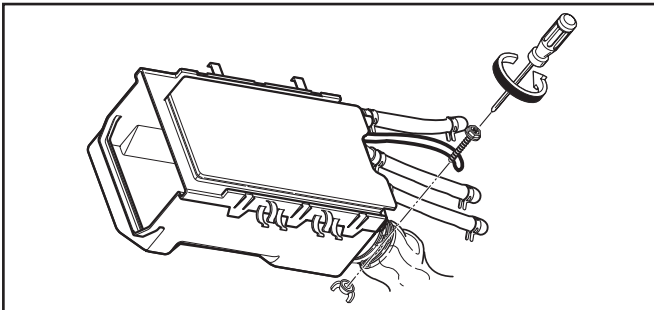

- ④ Unscrew the Clamp nut at the lower part of the dispenser.

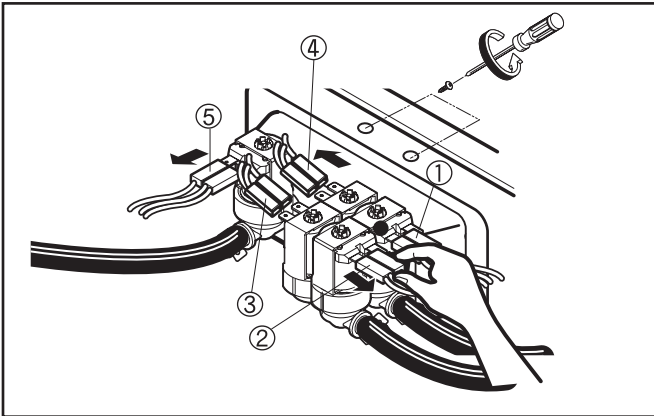

- ⑤ Disassemble the 4 connectors from the valves.

※ Wire Color

- ① Blue Housing (YL-BK)
- ② Red Housing (VT-BK)
- ③ White Housing (WH-BK)
- ④ Blue Housing (GY-BK)
- ⑤ Red Housing (BL-BK)

- ⑥ Unscrew 2 screws from the back of the cabinet.

NOISE FILTER

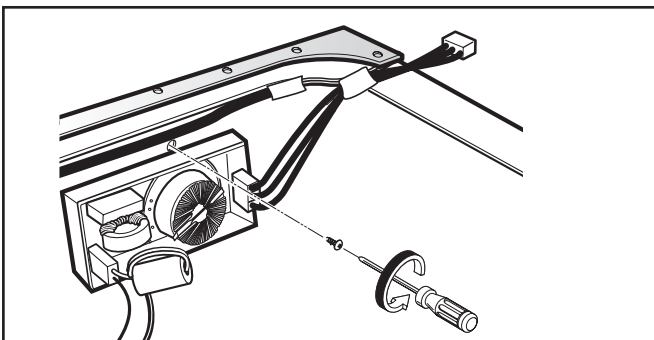

- ① Disassemble two (or three) connectors from the NOISE FILTER.
- ② Unscrew a screw from the TOP BRACKET.

CABINET COVER

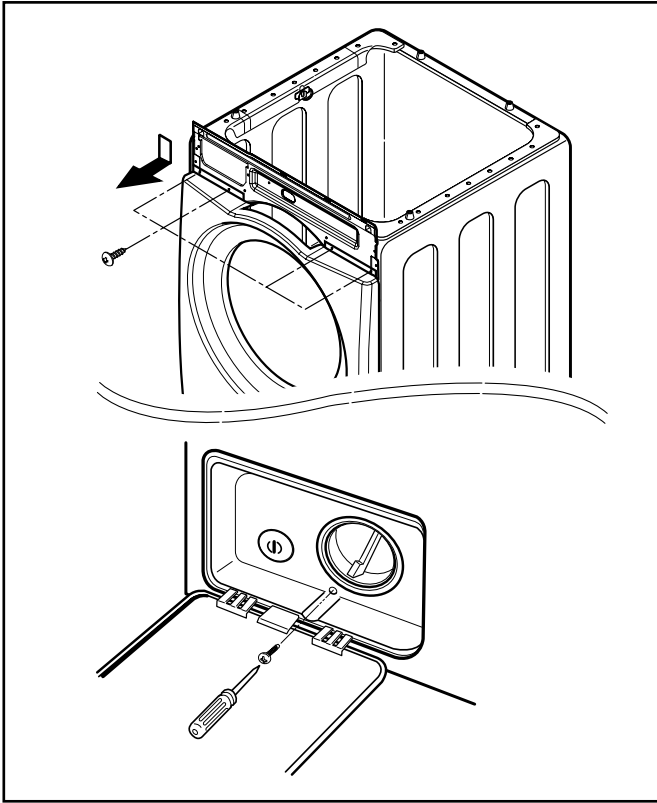

- ① Unscrew the 5 screws from upper of the cabinet cover.
- ② Unscrew the screw from filter cover.

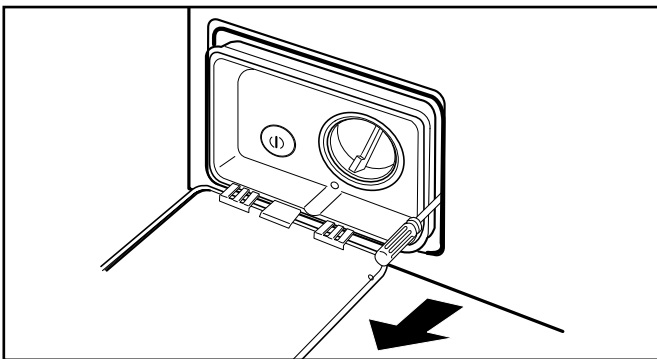

- ③ Put a flat (-) screwdriver or putty knife into the hinge slots at the bottom of the cover and pry it out.

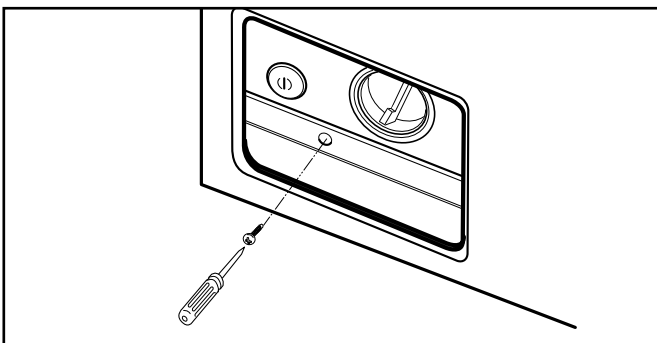

- ④ Unscrew the screw from the lower side of the cabinet cover.

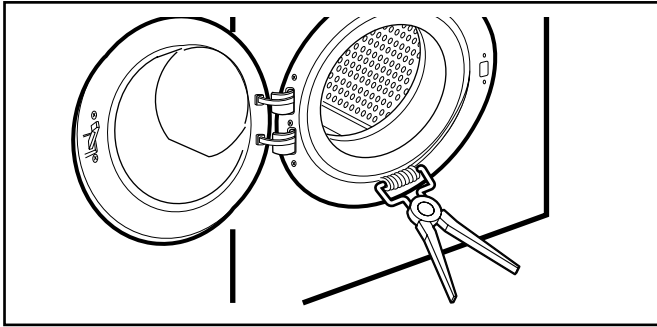

⑤ Open the door.

⑥ Disassemble the clamp assembly.

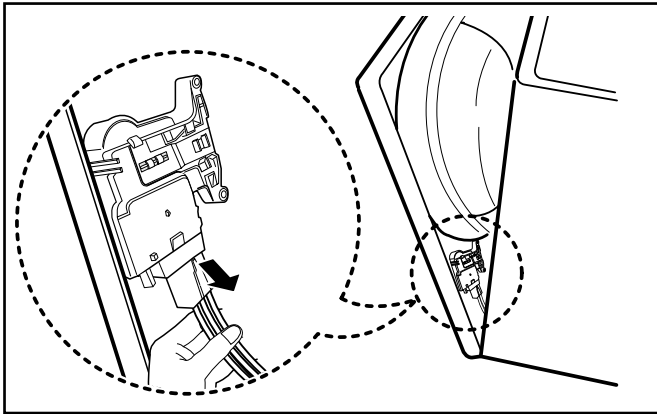

⑦ Tilt the cabinet cover.

⑧ Disconnect the door switch connector.

※ **NOTE:** When assembling the CABINET COVER, connect the door switch connector.

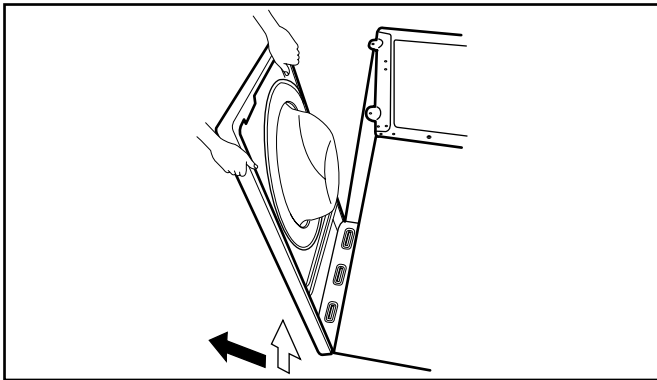

⑨ Lift and separate the cabinet cover.

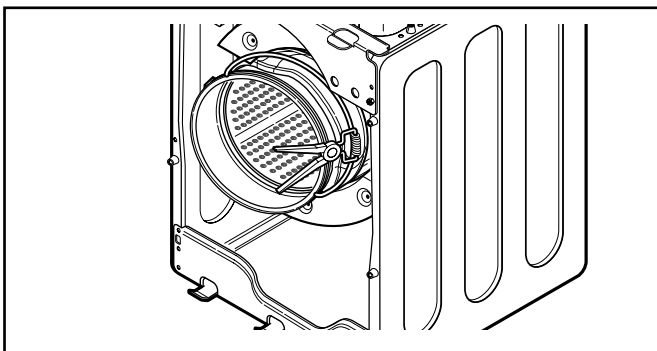

⑩ Disassemble the clamp assembly.

⑪ Disassemble the gasket.

DOOR

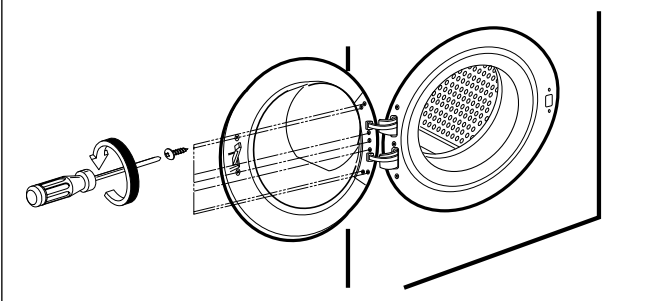

- ① Open the door.
- ② Unscrew the 7 screws from the HINGE COVER.

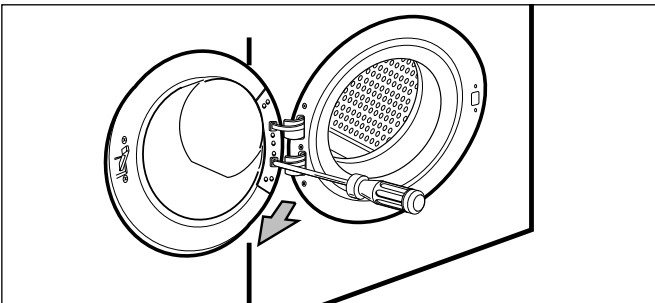

- ③ Put a flat (-) screwdriver into the opening of the hinge, and pull out the hinge cover.

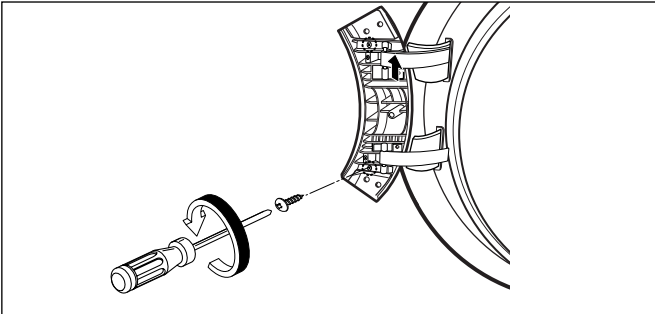

- ④ Unscrew a screw from the lower side of door.
- ⑤ Disassemble the door upward.

※ **Be careful!** The door is heavy.

DOOR LOCK SWITCH ASSEMBLY

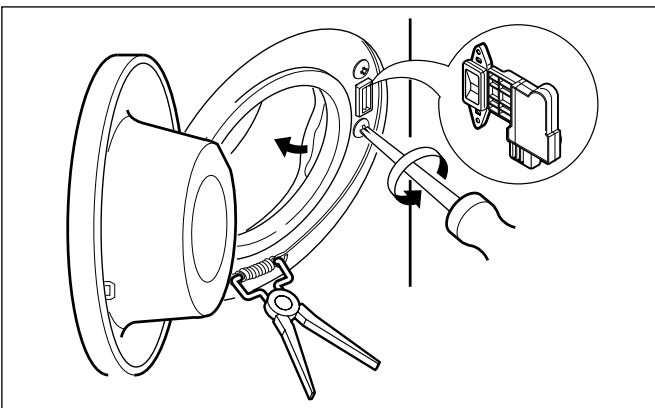

- ① Open the door and disassemble the CLAMP ASSEMBLY.
- ② Unscrew the 2 screws.

※ NOTE

- Reconnect the connector after replacing the DOOR SWITCH ASSEMBLY.

PUMP

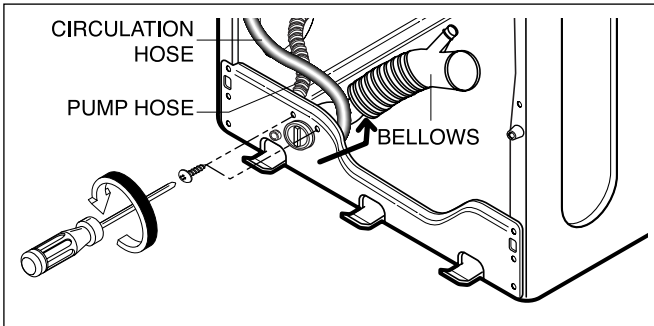

- ① Disassemble the cabinet cover.
- ② Separate the pump hose, the bellows and the circulation hose assembly from the pump assembly.
- ③ Disassemble the pump assembly in arrow direction.

HEATER

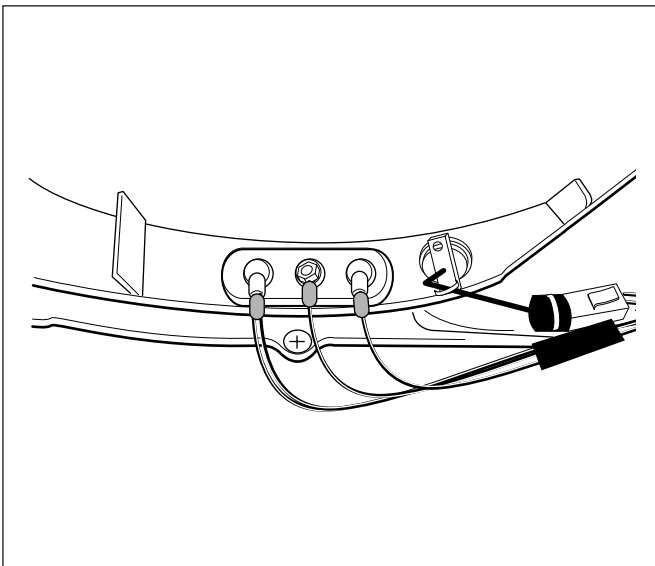

- ① Disassemble the cabinet cover.
- ② Separate 2 connectors from the heater.
- ③ Loosen the nut and pull out the heater.

※ CAUTION

- When assembling the heater, insert the heater into the heater clip on the bottom of the tub.
- Tighten the fastening nut so the heater is secure.

THERMISTOR

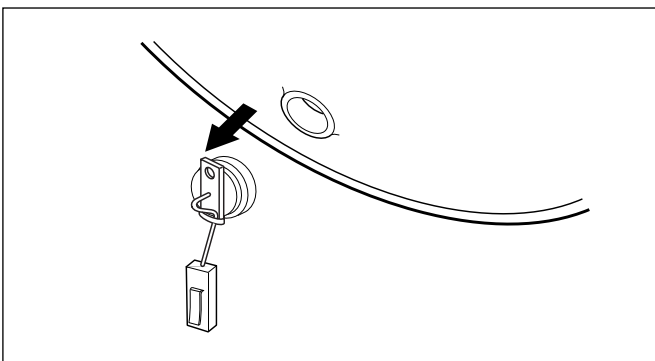

- ① Disassemble the cabinet cover.
- ② Unplug the white connector from the thermistor.
- ③ Pull it out by holding the bracket of the thermistor.

WHEN FOREIGN OBJECT IS STUCK BETWEEN DRUM AND TUB

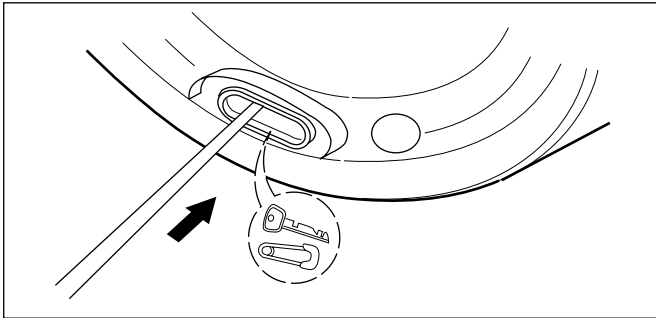

- ① Disassemble the cabinet cover.
- ② Separate the heater from the tub.
- ③ Remove any foreign objects (wire, coin, etc.) by inserting a long bar in the opening.

LAMP ASSEMBLY

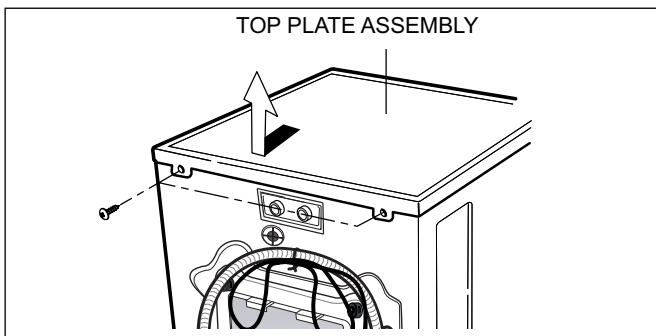

- ① Unscrew 2 screws on the back of the top plate.
- ② Pull the top plate backward and upward as shown.

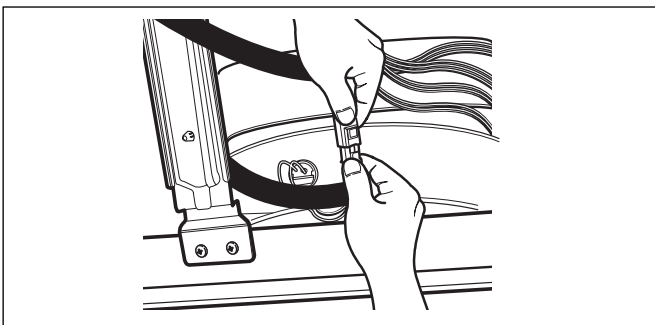

- ③ Disconnect the connector.

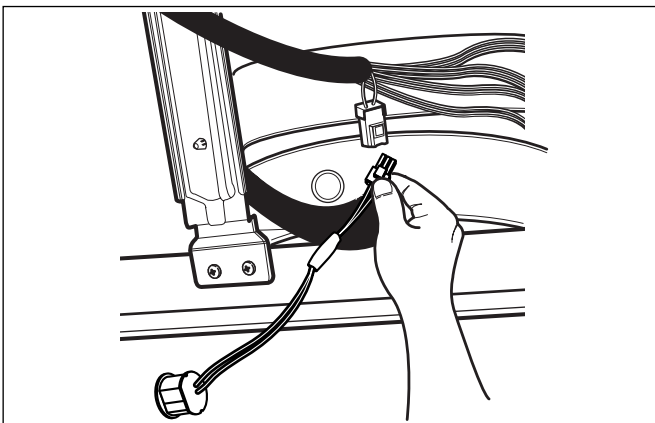

- ④ Disassemble the lamp assembly.

MOTOR/DAMPER

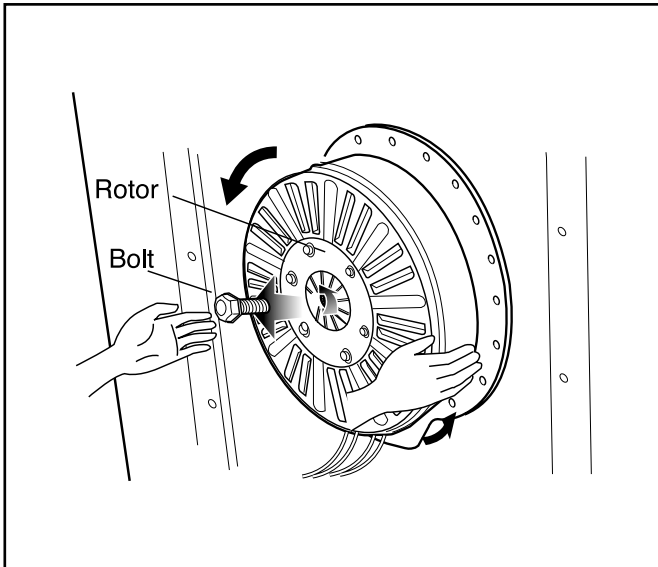

- ① Disassemble the back cover.
- ② Remove the bolt.
- ③ Pull out the Rotor.

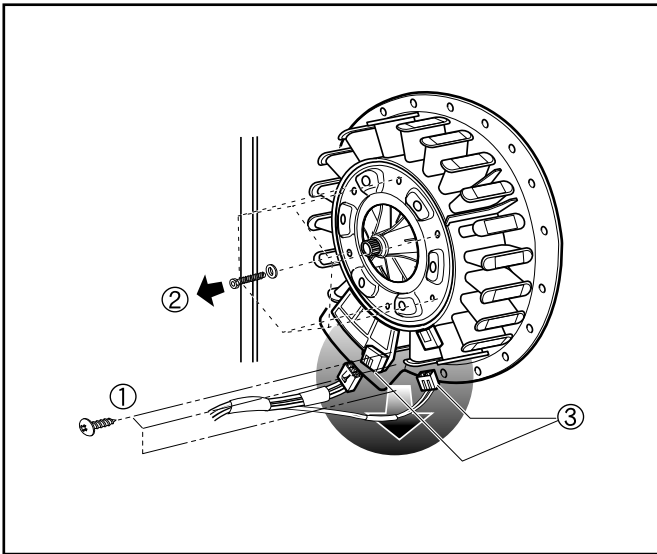

- ① Unscrew the 2 screws from the tub bracket.
- ② Remove the 6 bolts on the stator.
- ③ Unplug the 2 connectors from the stator.

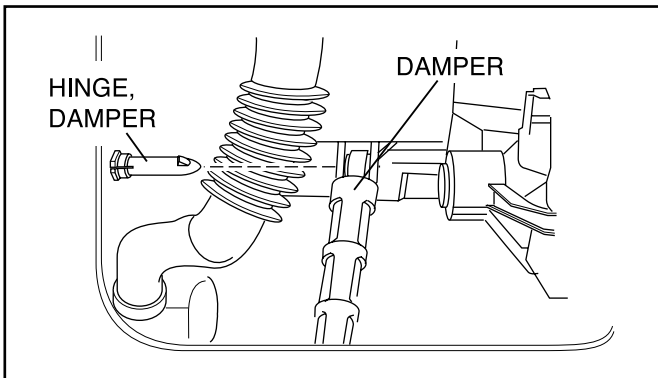

- ① Disassemble the damper hinges from the tub and base.

※ NOTE

If you pull the dampers apart, they must be replaced. If you do not separate them, they can be re-used.

Checking the TSG (TURBO STEAM GENERATOR)

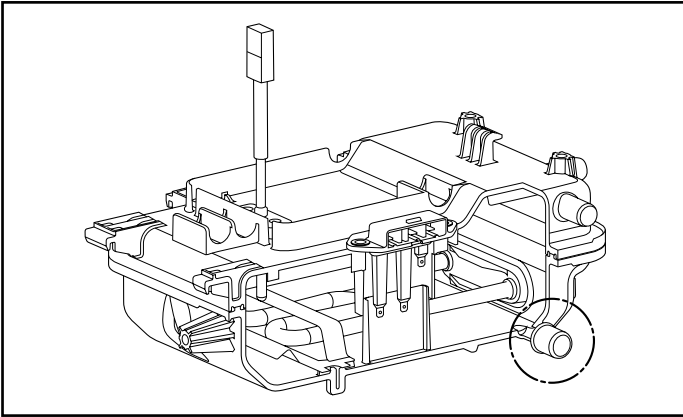

① To check out the fault diagnosis of TSG, you can pull out the plug and let the water drain away.

② Be cautious in case of the TSG is hot.

TSG (TURBO STEAM GENERATOR)

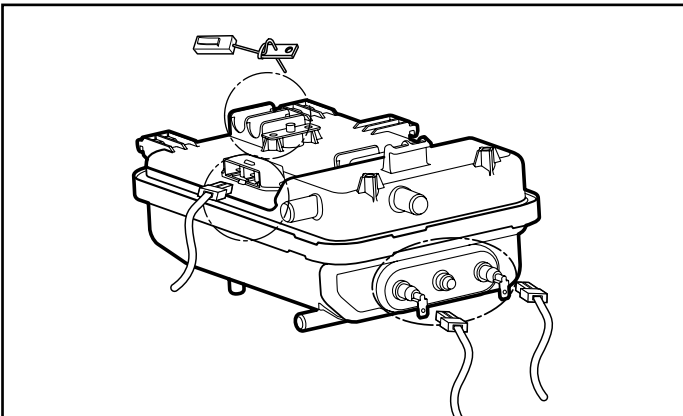

① Remove the housing attached to the TSG (Heater, Water level frequency-sensor, Thermistor)

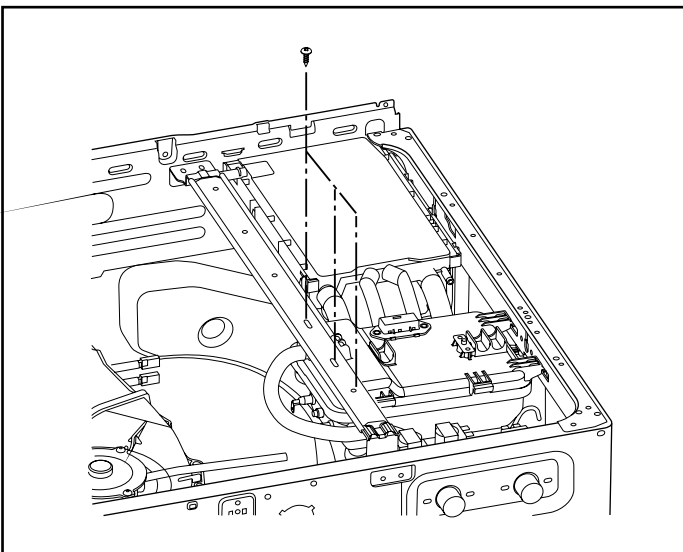

② Remove the screw of the TSG and Body Frame.

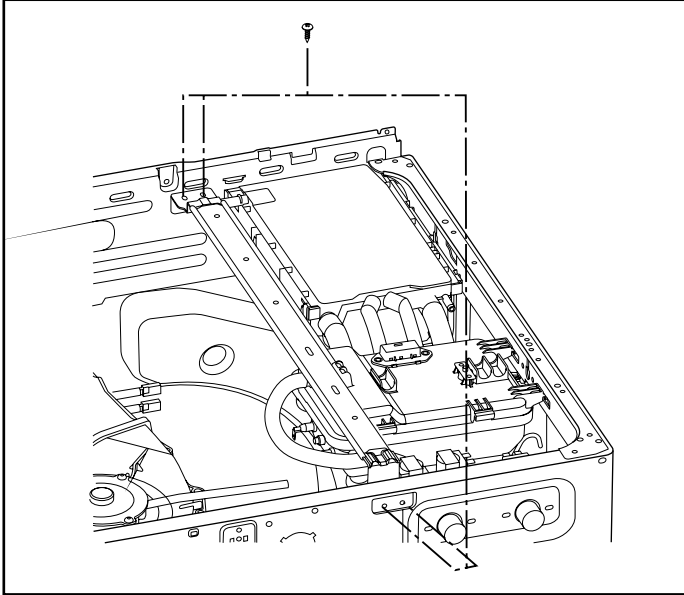

③ Taking out the screws of Body Frame (2 ea)

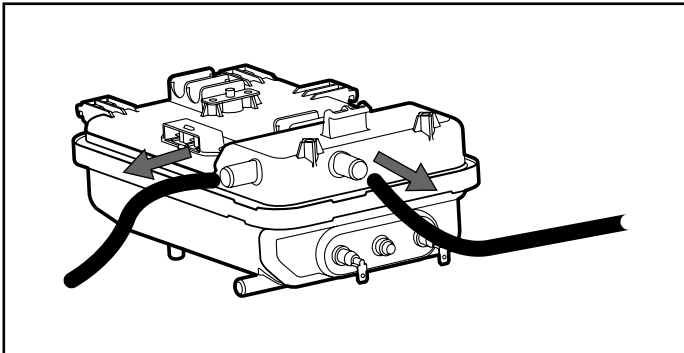

④ Separate the hoses from the TSG.

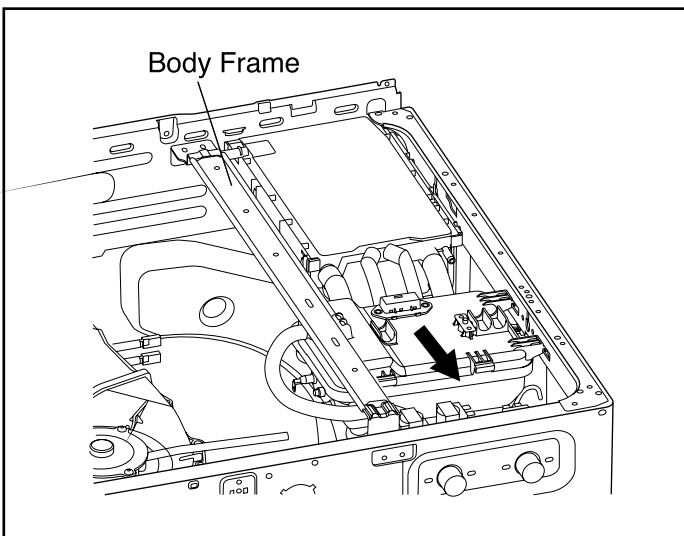

⑤ Remove the body frame and then, separate the TSG from the washer

11. EXPLODED VIEW

11-1. CABINET & CONTROL PANEL ASSEMBLY

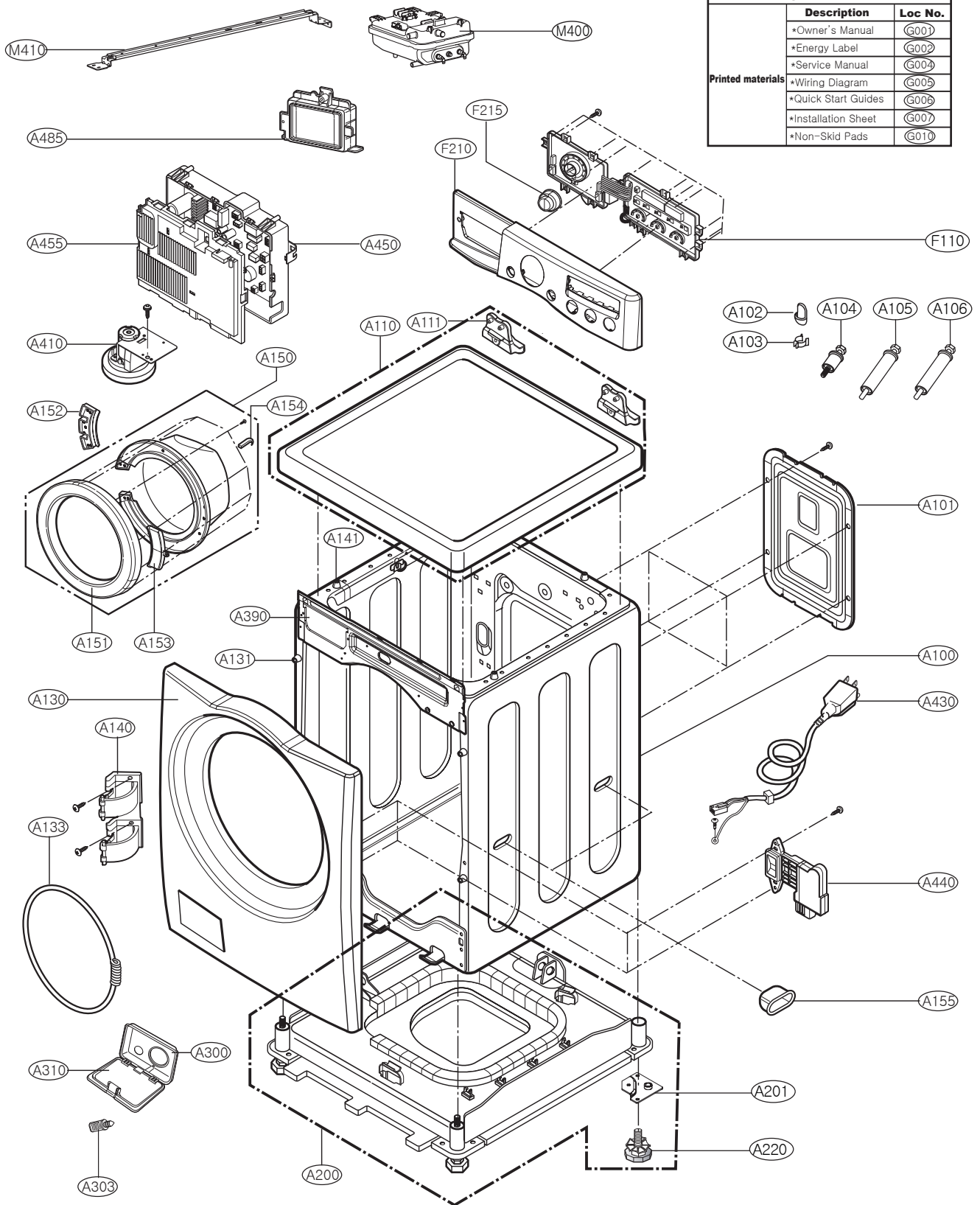

11-3. DISPENSER ASSEMBLY

