

This Owner's Manual is provided and hosted by [Appliance Factory Parts](#).



Grand Hall PREMIUM 325 Owner's Manual

[Shop genuine replacement parts for Grand Hall
PREMIUM 325](#)



[Find Your Grand Hall Grill Parts - Select From 203 Models](#)

----- Manual continues below -----

Portable Gas Barbecues

Operating and assembly instructions

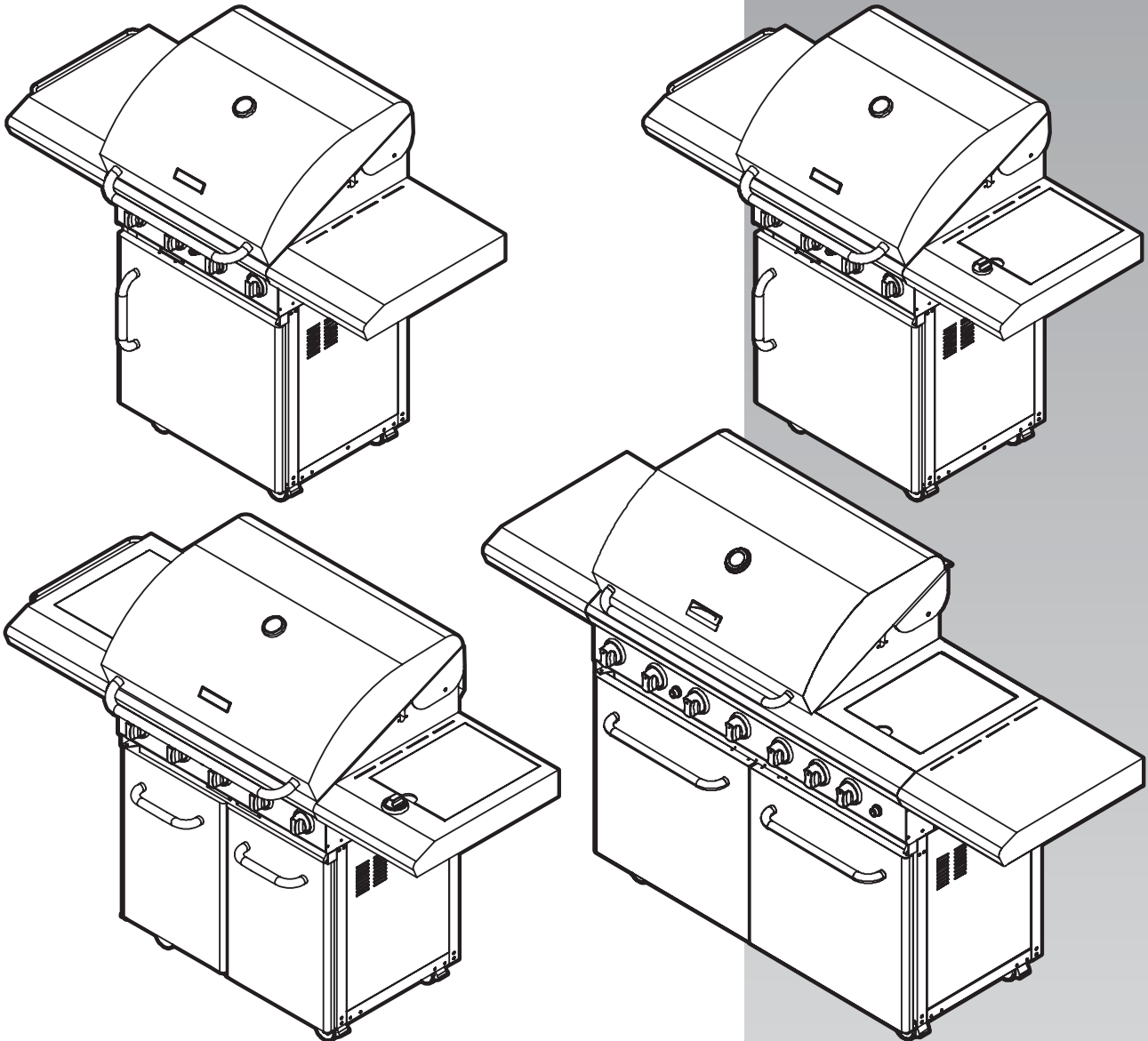

FOR YOUR SAFETY.

IF YOU SMELL GAS:

1. Shut off gas to the appliance, if possible.
2. Extinguish any open flame.
3. Open hood.
4. If odour continues, immediately call your gas supplier or fire department.

FOR YOUR SAFETY.

1. Do not store or use petrol or other flammable vapours and liquids in the vicinity of this or any other appliance.
2. A gas cylinder not connected for use must not be stored in the vicinity of this or any other appliance.

These instructions are a guide to assembling and using barbecue models Premium 321S, Premium 323, Premium 325, Premium 326, Premium 326X, Premium 327, Professional 529, Professional 584.

Please read carefully, and retain for future reference.

Only to be used outdoors. Illustration may vary from barbecue contained in carton.

TABLE OF CONTENTS

General Information	2
Safety	3-5
Pre-Assembly	6
Assembly: Premium 321S, 323, 325 models	7-11
Premium 326, 326X, 327, Professional 529 models	12-17
Professional 584 model	18
Operation: General	19-22
Premium 321S, 323, 325, 326, 326X, 327 models	24
Professional 529 model	24
Professional 584 model	25
Fault Finding	28
Maintenance	29-31
Contacts	32

FOR CUSTOMER REFERENCE

(Record and file in a safe place)

Purchased from _____

Date purchased _____

Serial No. _____

NOTE: Sales docket must be kept as proof of purchase date.

Barbecues for use with bottled gas are labelled 'Universal LPG' or 'Propane'. Barbecues for use with natural gas are labelled 'Natural Gas' and must be installed by an authorised person. Check the gas type sticker attached to the barbecue. Check that the label matches the gas type to be used.

Your barbecue is preset at the factory to operate on bottled gas only, unless specified otherwise.



- **FAILURE TO COMPLY WITH THESE INSTRUCTIONS COULD RESULT IN A FIRE OR EXPLOSION WHICH COULD CAUSE SERIOUS BODILY INJURY, DEATH OR PROPERTY DAMAGE**
- **ACCESSIBLE PARTS MAY BE VERY HOT**
- **KEEP YOUNG CHILDREN AWAY**
- **ANY MODIFICATION OF THIS APPLIANCE MAY BE DANGEROUS**
- **DO NOT MOVE THIS APPLIANCE DURING USE**
- **TURN OFF THE GAS SUPPLY AT THE GAS CYLINDER AFTER USE**
- **READ THE INSTRUCTIONS BEFORE USING THE APPLIANCE**
- **PARTS SEALED BY THE MANUFACTURER MUST NOT BE ALTERED IN ANY WAY**
- **THIS BARBECUE IS ONLY TO BE USED OUTDOORS.**

SPECIFICATIONS

Appliance specifications can be found on the data label attached to the side panel of the barbecue body.

GAS INSTALLATION CODES

This appliance is certified to AS 4557 by the Australian Gas Association.

Barbecues must be used in accordance with the installation requirements of your local gas supply authority, and the appropriate installation standard AS5601.

HOSE CONNECTIONS

$\frac{5}{8}$ "-18 UNF ($\frac{3}{8}$ " SAE FLARE).

CLEARANCES

The following minimum clearances from combustible materials must be maintained when barbecue is in use:
top – 1000 mm, rear – 450 mm, sides – 250 mm.

Openings at the rear and sides of the appliance provide air for combustion and must not be obstructed.

HOSE AND REGULATOR SAFETY



NEVER OPERATE THIS BARBECUE WITHOUT A REGULATOR.

The regulator and hose assembly supplied with the barbecue are suitable for use with bottled gas – POL connection.

This regulator is adjusted to have an outlet pressure of 2.75 kPa for connection to a gas cylinder only. The regulator and hose assembly supplied with the appliance must be used. Replacement regulator and hose assemblies must be those specified by the appliance manufacturer.

When connecting the hose and regulator assembly to the gas cylinder, take care to avoid unnecessary twisting of the flexible hose. Also, take care to avoid a loose connection with the gas cylinder. After the assembly has been secured, turn on the gas and check for leaks by brushing a liquid detergent and water solution over all visible and accessible gas line connections. Include checking those connections which were made by your supplier. The presence of bubbles will indicate a gas escape. **DO NOT TEST FOR GAS ESCAPES WITH AN OPEN FLAME.** If you are unable to correct the leak by tightening the connections, turn off the gas and contact your place of purchase immediately.

Always ensure the appliance is kept away from flammable materials and the gas cylinder clear of any heat source. When changing over from an empty gas cylinder to a full one, make sure this procedure is carried out in a flame free atmosphere.

Inspect the gas hose assembly when exchanging the gas cylinder, or at least once a year, whichever is more frequent. If the 'O-Ring' or PVC hose is cracked, cut, abraded or damaged in any way, the appliance must not be operated. The complete assembly must be replaced if damaged and when statutory conditions require it. Contact your place of purchase if uncertain.

OVERALL DIMENSIONS

Height – All models: hood closed 1215 mm, hood open 1590 mm
Width – Premium 321S, 323, 325 models: 1462 mm
 Premium 326, 326X, 327, 329, 325 models: 1690 mm
 Professional 529 model: 1690 mm
 Professional 584 model: 2070 mm
Depth – All models: hood closed 660 mm, hood open 720 mm



READ CAREFULLY BEFORE ASSEMBLING AND OPERATING YOUR BARBECUE.



FOR YOUR SAFETY:

- **DO NOT STORE OR USE PETROL OR OTHER FLAMMABLE VAPOURS AND LIQUIDS IN THE VICINITY OF THIS OR ANY OTHER APPLIANCE.**
- **DO NOT STORE EMPTY OR FULL SPARE GAS CYLINDERS UNDER OR NEAR THIS OR ANY OTHER APPLIANCE.**
- **KEEP THE GAS HOSE AWAY FROM HOT SURFACES. PROTECT GAS HOSE FROM DRIPPING GREASE. AVOID UNNECESSARY TWISTING OF HOSE. VISUALLY INSPECT HOSE PRIOR TO EACH USE FOR CUTS, CRACKS, EXCESSIVE WEAR OR OTHER DAMAGE. REPLACE HOSE, IF NECESSARY.**
- **NEVER TEST FOR GAS LEAKS WITH A LIT MATCH OR OPEN FLAME.**
- **NEVER LIGHT BARBECUE WITH LID ON OR HOOD CLOSED.**
- **NEVER LEAN OVER COOKING SURFACE WHILE LIGHTING BARBECUE.**
- **USE GOOD QUALITY INSULATED OVEN MITTS WHEN OPERATING BARBECUE.**
- **NEVER ALTER OR MODIFY THE REGULATOR OR GAS SUPPLY ASSEMBLY.**
- **THIS BARBECUE MUST NOT BE USED INDOORS.**

SERVICING



ANY OF THE FOLLOWING SIGNS MAY INDICATE THAT THE APPLIANCE IS NOT OPERATING PROPERLY AND MAY NEED SERVICING:

- **EXCESSIVE YELLOW FLAME.**
- **IRREGULAR SIZE OF FLAME ACROSS BURNER.**
- **'POPPING' OF FLAME.**
- **SOOTING.**
- **ABNORMAL NOISE(S).**
- **HISSING SOUND.**

NOTE: Before requesting service, please refer to page 28 'Fault Finding'.

PROTECT CHILDREN

Keep children away from barbecue during use and until barbecue has cooled after you are finished. Do not allow children to operate barbecue or to swing on handle.

GAS CYLINDER USE AND SAFETY

This is a low pressure barbecue and must only be used with the hose and regulator supplied.

Your barbecue is designed for use with a 9 kg gas cylinder. Ensure gas cylinder conforms to Australian Standard AS2469 and is less than 10 years old, or re-certified if older than 10 years.

DO NOT CONNECT YOUR BARBECUE TO A GAS CYLINDER LESS THAN OR EXCEEDING 9 kg CAPACITY.



NEVER CONNECT AN UNREGULATED GAS CYLINDER TO YOUR BARBECUE.

NOTE: The connection to the gas cylinder is an 'ANTI-CLOCKWISE' connection.

Ensure the connection is tightened firmly. Normally only 1-1½ threads of the hose assembly connection should remain visible.

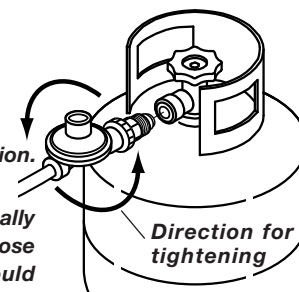

The gas cylinder should be filled by a reputable gas dealer, or exchanged at a reputable gas cylinder exchange outlet. Gas cylinders should be visually inspected and re-qualified periodically.

Always keep gas cylinder in an upright position. Always close the cylinder valve when the barbecue is not in use.

Do not subject the gas cylinder to excessive heat.



- **NEVER STORE YOUR GAS CYLINDER INDOORS.**
- **FOR STORAGE AND CYLINDER EXCHANGE, DISCONNECT HOSE AT THE CYLINDER ONLY. DO NOT DISCONNECT HOSE FROM THE APPLIANCE.**

If you store your barbecue indoors, ALWAYS disconnect and remove gas cylinder FIRST, and store gas cylinder safely outside. Gas cylinders must be stored outdoors in a well ventilated area out of reach of children, and must not be stored in a building, garage or any other enclosed area.



DANGER – IF YOU SMELL OR HEAR THE HISS OF ESCAPING GAS FROM THE GAS CYLINDER:

- **KEEP CLEAR OF THE GAS CYLINDER.**
- **TURN ALL CONTROLS ON THE BARBECUE TO 'OFF', IF SAFE TO DO SO.**
- **EXTINGUISH ANY OPEN FLAME.**
- **REMOVE LID OR OPEN HOOD.**
- **IF ODOUR CONTINUES, IMMEDIATELY CALL YOUR GAS SUPPLIER OR FIRE BRIGADE.**



**ALWAYS CHECK FOR GAS LEAKS
EACH TIME YOU USE YOUR BARBECUE.**

You should follow this procedure after any of the following:

- Not having used the barbecue for an extended period of time,
- Initial assembly of barbecue,
- Any disconnection and reconnection of hose assembly,
- Changing gas cylinder,
- Upon re-connecting gas cylinder after it has been disconnected for storage.

CHECKING FOR GAS LEAKS



**NEVER CHECK FOR LEAKS WITH
A FLAME.**

1. Make liquid detergent solution by mixing one (1) part liquid detergent and four (4) parts water.

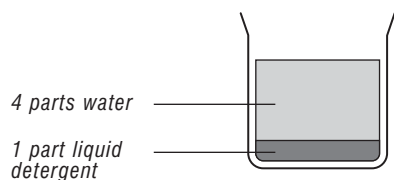

2. Turn burner control(s) to 'OFF', then turn on gas at source.

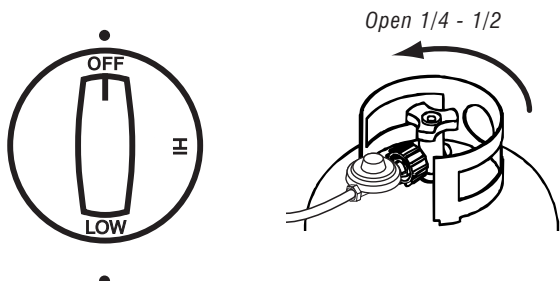

3. Apply the liquid detergent solution to all visible and accessible gas connections, including the connection to the gas cylinder. Bubbles will appear in the liquid detergent solution if connections are not properly sealed. Tighten or rectify as necessary.

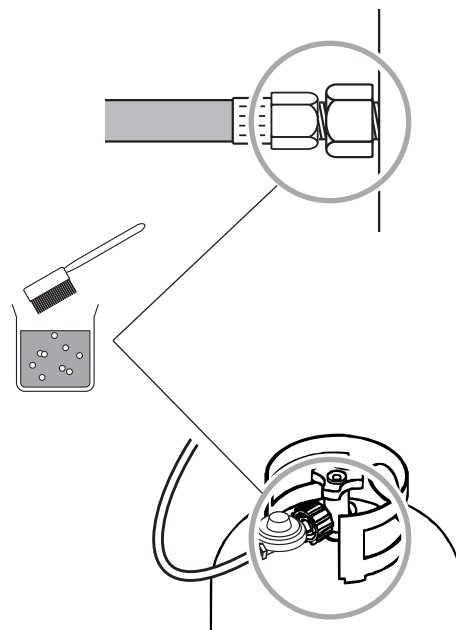

**IF YOU HAVE A GAS LEAK YOU
CANNOT RECTIFY, TURN OFF THE GAS
AT THE SOURCE. CONTACT THE
MANUFACTURER OR PLACE OF
PURCHASE.**



THIS APPLIANCE SHALL ONLY BE USED IN AN ABOVE GROUND OPEN AIR SITUATION WITH NATURAL VENTILATION, WITHOUT STAGNANT AREAS, WHERE GAS LEAKAGE AND PRODUCTS OF COMBUSTION ARE RAPIDLY DISPERSED BY WIND AND NATURAL CONVECTION.

ANY ENCLOSURE IN WHICH THE APPLIANCE IS USED SHALL COMPLY WITH ONE OF THE FOLLOWING:

- **AN ENCLOSURE WITH WALLS ON ALL SIDES, BUT AT LEAST ONE PERMANENT OPENING AT GROUND LEVEL AND NO OVERHEAD COVER**
 - **WITHIN A PARTIAL ENCLOSURE THAT INCLUDES AN OVERHEAD COVER AND NO MORE THAN TWO WALLS**
 - **WITHIN A PARTIAL ENCLOSURE THAT INCLUDES AN OVERHEAD COVER AND MORE THAN TWO WALLS, THE FOLLOWING SHALL APPLY:**
 - (i) **AT LEAST 25% OF THE TOTAL WALL AREA IS COMPLETELY OPEN: AND**
 - (ii) **AT LEAST 30% OF THE REMAINING WALL AREA IS OPEN AND UNRESTRICTED**
 - **IN THE CASE OF BALCONIES, AT LEAST 20% OF THE TOTAL OF THE SIDE, BACK AND FRONT WALL AREAS SHALL BE AND REMAIN OPEN AND UNRESTRICTED**
 - **DO NOT USE YOUR BARBECUE IN GARAGES, PORCHES, BREEZEWAYS, SHEDS OR OTHER ENCLOSED AREAS.**
- YOUR BARBECUE IS TO BE USED OUTDOORS ONLY. Refer below.**
- **THE BARBECUE IS NOT INTENDED TO BE INSTALLED IN OR USED ON RECREATIONAL VEHICLES AND/OR BOATS AND SHOULD NOT BE PLACED ADJACENT TO OR UNDER ANY SURFACE THAT WILL BURN.**
 - **DO NOT OBSTRUCT THE FLOW OF COMBUSTION AND VENTILATION AIR AROUND THE BARBECUE HOUSING WHILST IN USE.**

The following diagrams are examples of outdoor areas.
These same principles apply to canopy or shaded cloth areas.

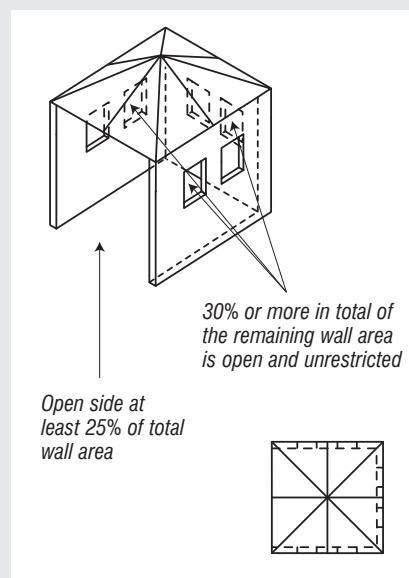
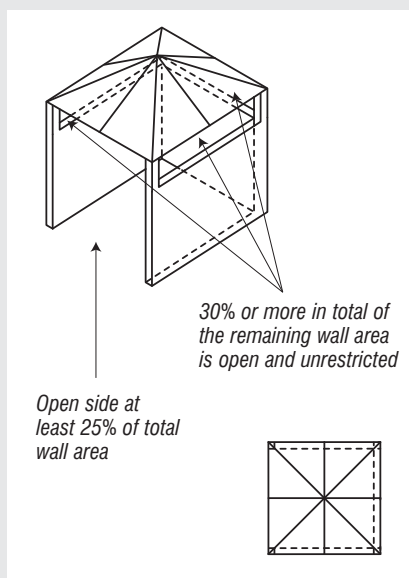
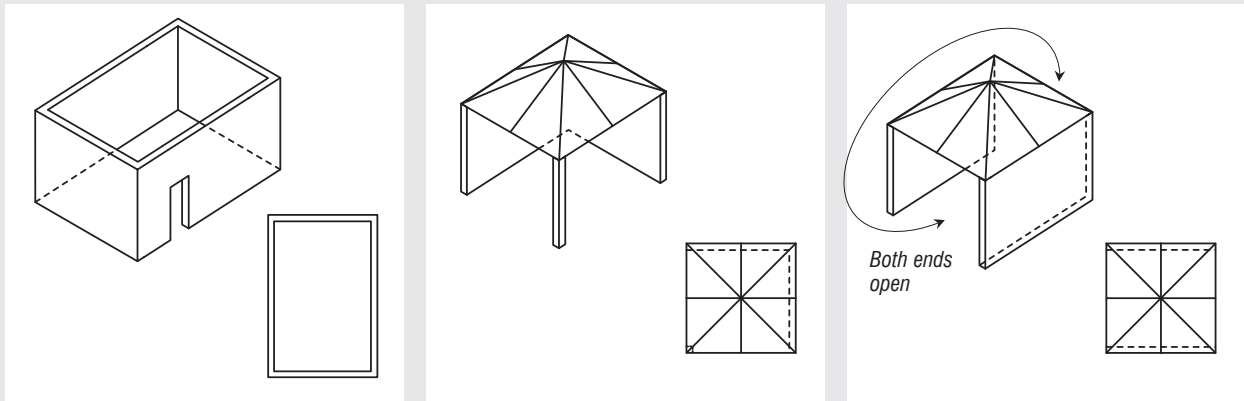

INSTALL CASTORS**- Premium 321S, 323, 325 models**

- Place the trolley bottom shelf on the cardboard work surface with the bottom side of shelf facing up. Install the four (4) castors onto the castor seats as shown.

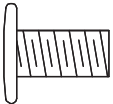

Phillips flat-head screw 1/4" x 1/2"

Qty: 16

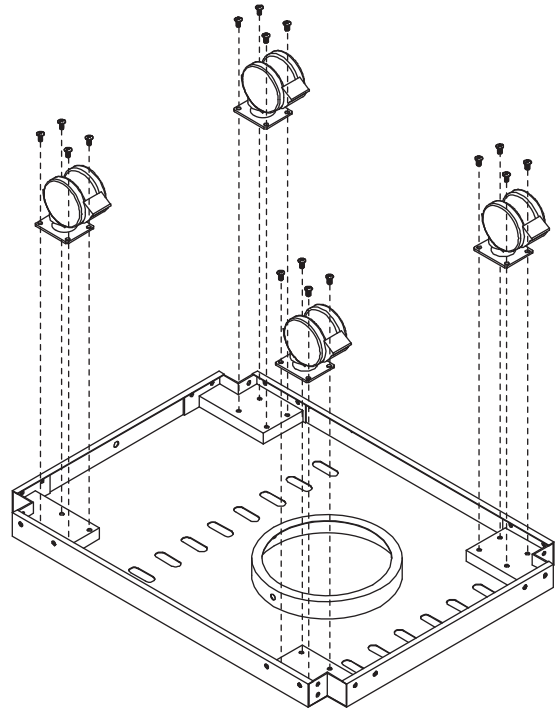
**INSTALL TROLLEY LEGS WITH SIDE PANELS**

- Install the left and right trolley legs with side panel (*parts are labelled 'L' or 'R'*) to trolley bottom shelf.

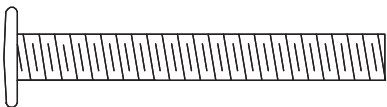

Phillips flat-head screw 1/4" x 2"

Qty: 8

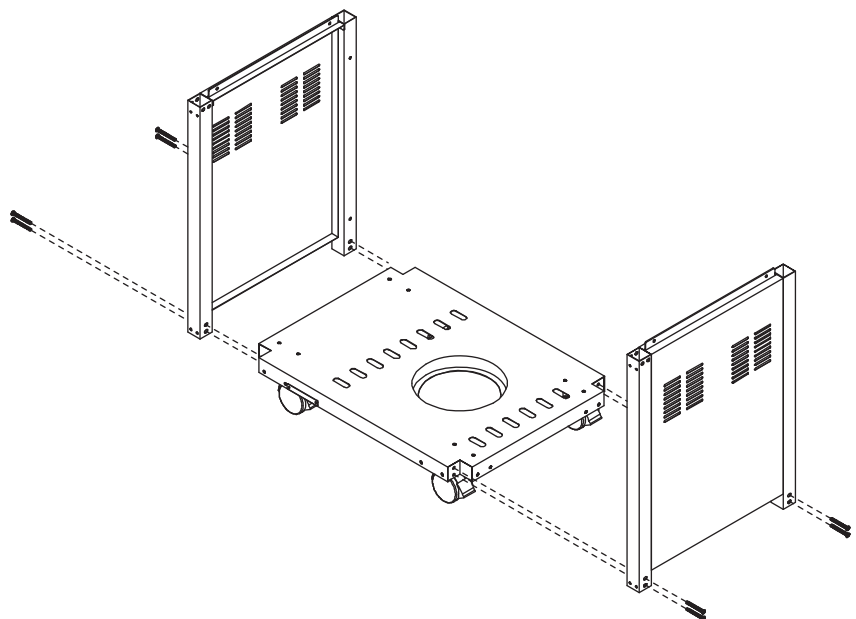

INSTALL TROLLEY REAR PANEL

- Install the trolley rear panel between rear trolley legs as shown.

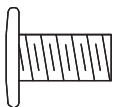

Phillips flat-head screw 1/4" x 1/2"

Qty: 4

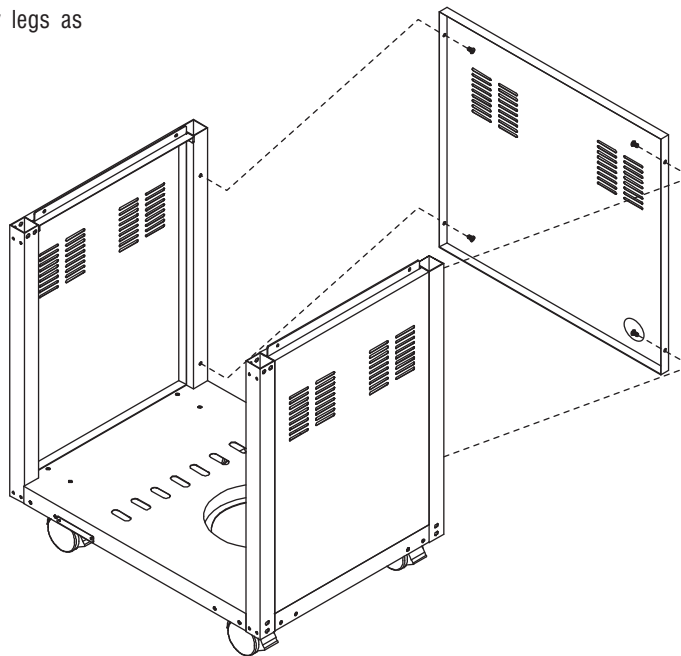
**INSTALL TROLLEY BRACKET**

- Install the trolley bracket in the up position (*part is labelled 'UP' to ensure proper assembly*) between front trolley legs as shown.

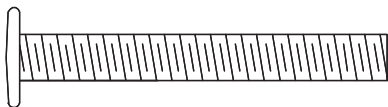

Phillips flat-head screw 1/4" x 2"

Qty: 4

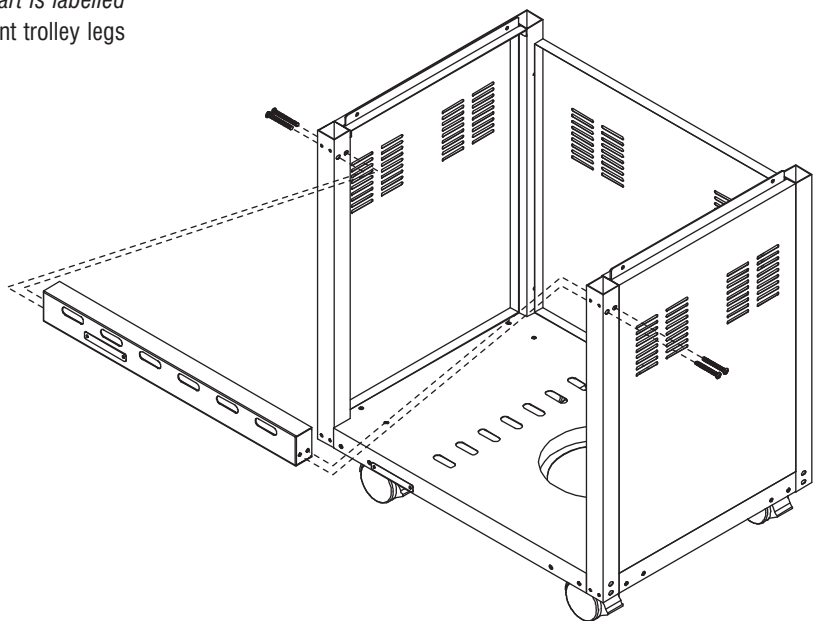

INSTALL DOOR

- Install the door handle to door.
- Install the bottom door hinge bracket to right trolley leg.
- Insert door bottom post into bottom door hinge bracket.
- Hold the door and install the top door hinge bracket to right trolley leg.

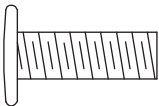
*Door handles*

Phillips flat-head screw $1/4" \times 3/4"$
(Stainless steel) Qty: 2

*Door hinges*

Phillips-head screw $3/16" \times 3/8"$
Qty: 4

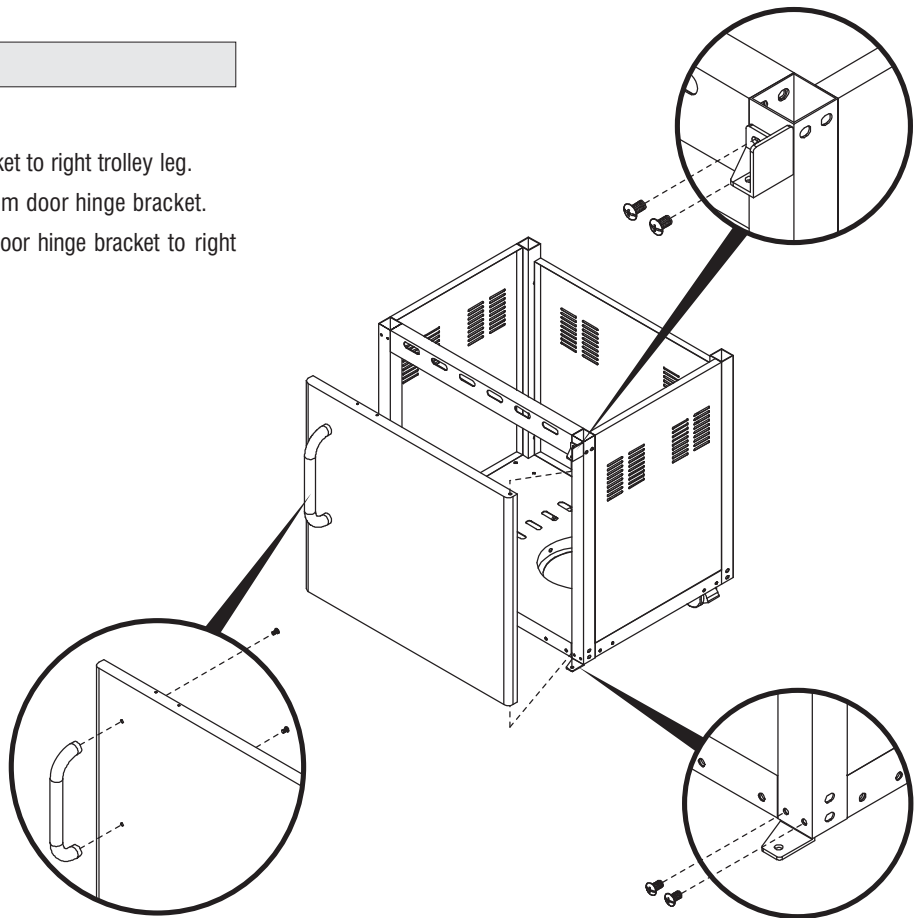
**INSTALL BARBECUE HEAD**

- Remove cooking components from barbecue head. With an assistant, lift and position barbecue head on the trolley.
- Tighten securely using screws.
- Attach the lighting stick to the left body panel using screw.

*Lighting stick to barbecue body*

Phillips-head screw M4 x 8 mm
Qty: 1

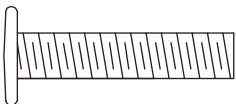
*Barbecue body to trolley*

Phillips flat-head screw $1/4" \times 13/16"$
Qty: 4

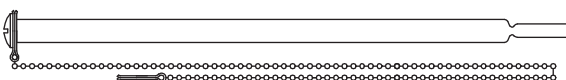
*Lighting stick*

Qty: 1

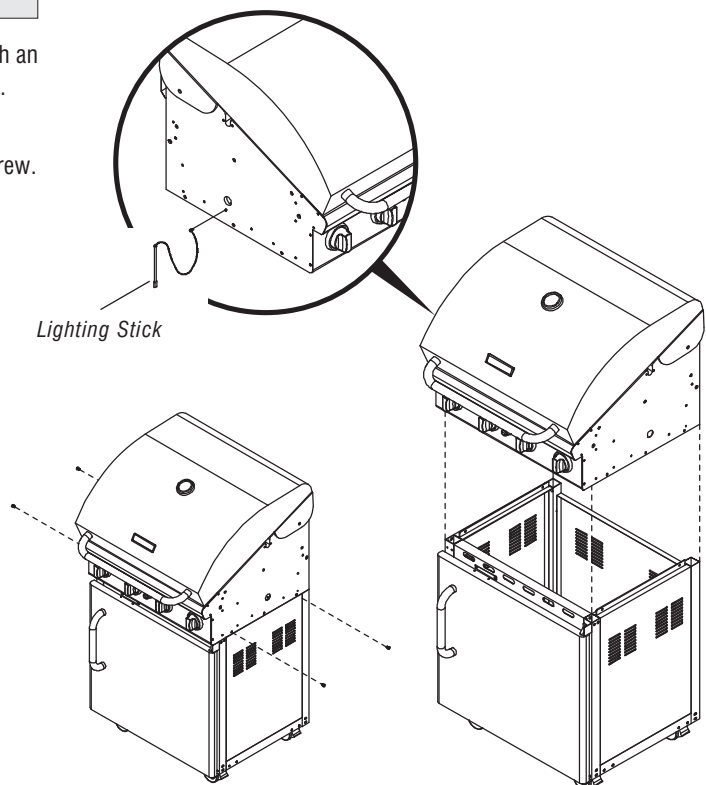

**INSTALL SIDE SHELF AND
SIDE BURNER FRAME**
(Premium 321S model has two side shelves)

- Remove screws from the tool holder. Slide the four (4) tool hooks onto the tool holder with the hooks facing the left side shelf. Attach tool holder to side shelf using these screws.
- Align the two (2) holes on front and rear body panels and three (3) holes on left body panel with the threaded holes on left side shelf. Insert the three (3) screws from the inside of the barbecue body and tighten securely.
- Align the two (2) holes on underside of left side shelf with the threaded holes on left body panel. Insert the two (2) screws and tighten securely.
- Repeat for right side burner frame (*right side shelf*).

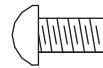

Tool holder to side shelf
Phillips-head screw
M5 x 8 mm

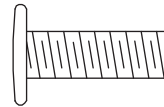

Side shelves / side burner to
barbecue head
Phillips flat-head screw
1/4" x 3/4"
Qty: 10

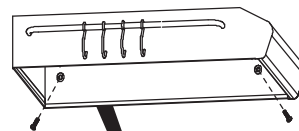
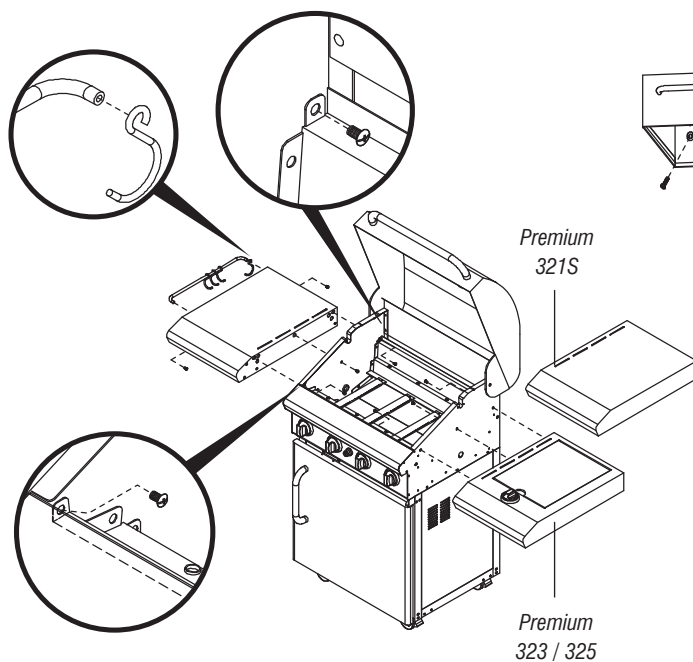

Inner side view of
left side shelf

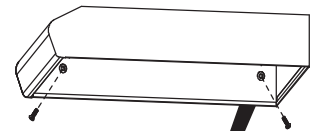

Inner side view of
Right side burner
frame (*right side shelf*)

NOTE: For Premium 321S model the side shelves may also be installed to the Premium Range and Premium Sink / Workstation modules. Refer to the appropriate instructions supplied with the modules.

CONNECT SIDE BURNER GAS VALVE – Premium 323, 325 models

NOTE: Remove plastic protection sleeve from male fitting before connecting side burner hose.

- Position hose socket over valve plug. See diagram A.
- Pull and hold back socket sleeve.
- Push socket to right until it firmly snaps into place over plug. See diagram B.
- Push sleeve to right until it fully snaps into place. See diagram C.
- Give hose a tug to left to insure connection is secure.

WARNING: Failure to securely connect hose socket to valve plug may result in gas leaks which can cause fire or explosion.

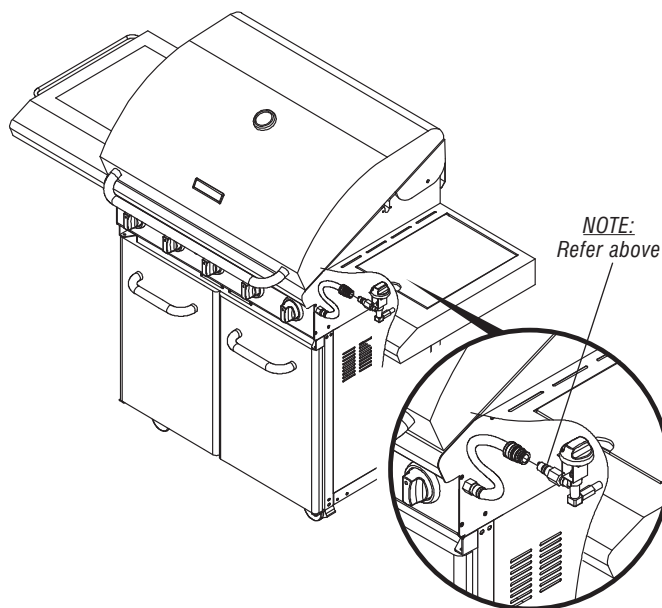
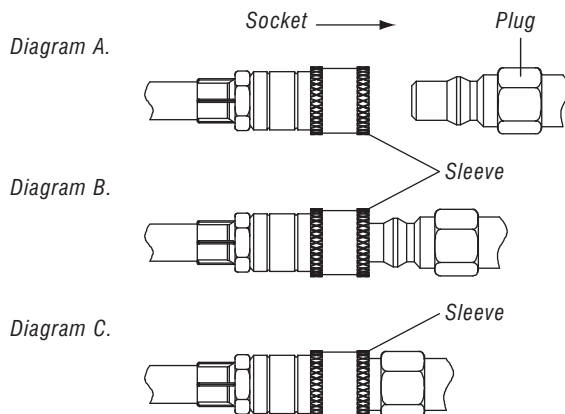

ASSEMBLE AND INSTALL GREASE DRAINING TRAY

- Remove plastic shipping bands attaching regulator to burner.
- Place the heat shield into grease draining tray making sure to fit the heat shield tabs into the slots in the base of the tray.
- From the back of the barbecue, slide the assembled tray side tabs over the side rails underneath the barbecue head.
- Install grease receptacle under the grease draining tray from the front of barbecue.

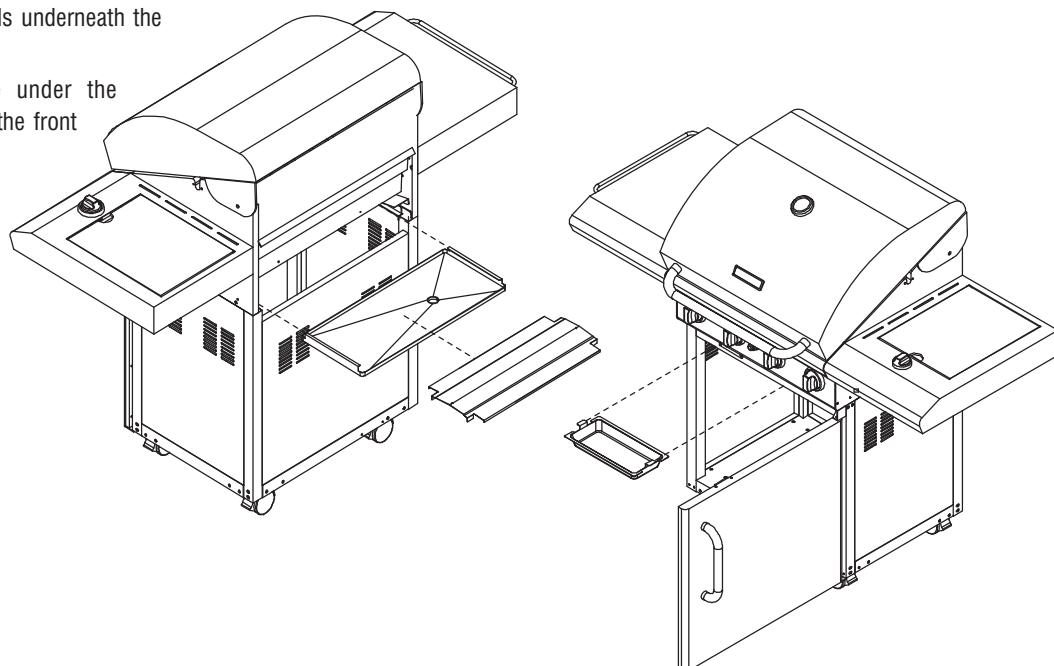

Premium 326, 326X & 327, Professional 529

NOTE: Professional 529 model does not have a hole in the base tray for the gas cylinder housing. Assembly diagrams are representative at some stages.

INSTALL CASTORS

- Place the trolley bottom shelf on the cardboard work surface with the bottom side of shelf facing up. Install the four (4) castors onto the castor seats as shown.

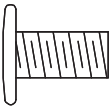

Phillips flat-head screw $\frac{1}{4}$ " x $\frac{1}{2}$ "
Qty: 16

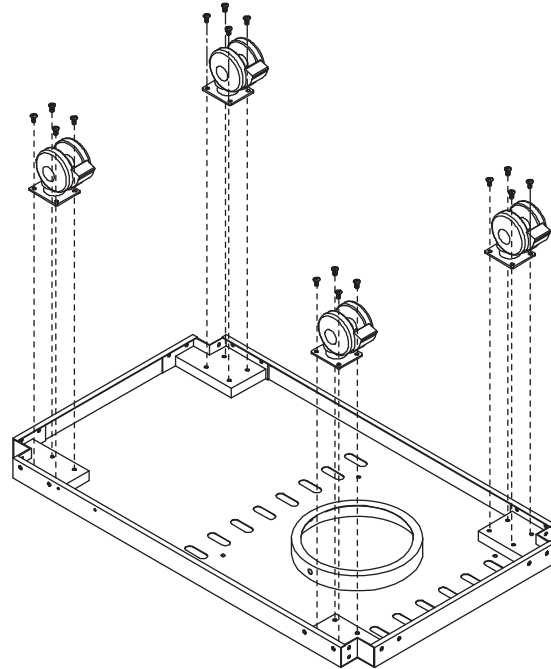

INSTALL TROLLEY LEGS WITH SIDE PANELS

- Install the left and right trolley legs with side panel (parts are labelled 'L' or 'R') to trolley bottom shelf.

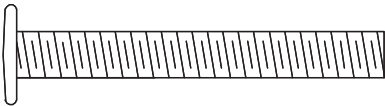

Phillips flat-head screw $\frac{1}{4}$ " x 2"
Qty: 8

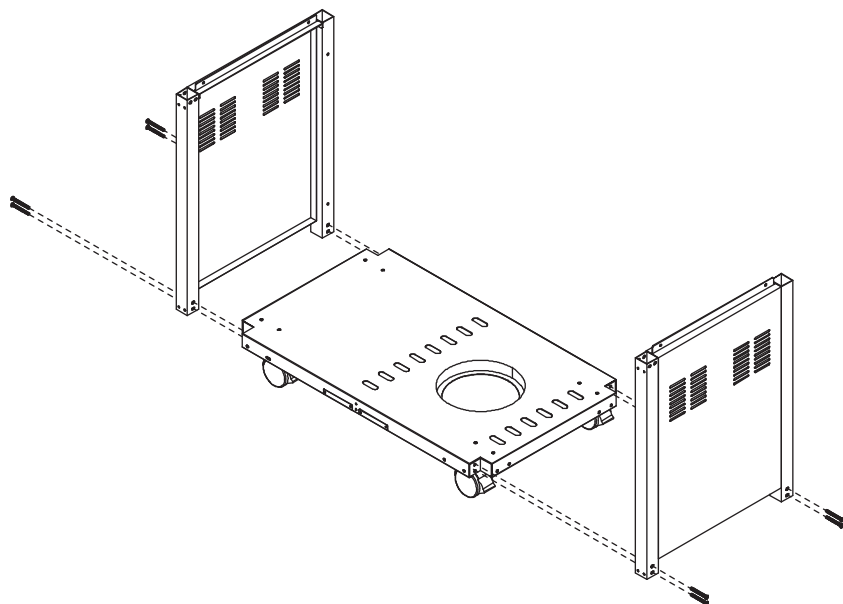

**INSTALL GAS CYLINDER PULL-OUT TRAY
(Professional 529 model)**

Install the cylinder pull-out tray to trolley bottom shelf.

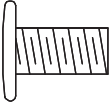

Phillips flat-head screw 1/4" x 1/2"
Qty: 4

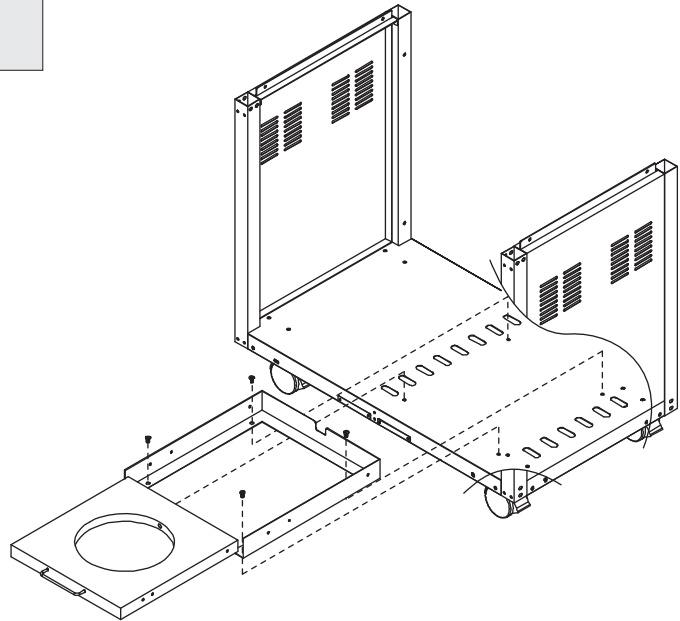
**INSTALL TROLLEY REAR PANEL**

- Install the trolley rear panel between rear trolley legs as shown.

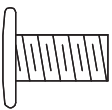

Phillips flat-head screw 1/4" x 1/2"
Qty: 4

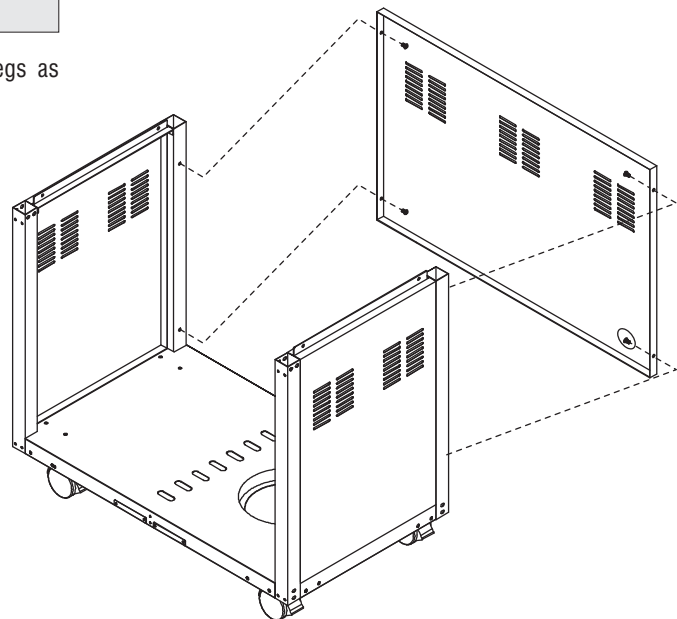

INSTALL LEFT PARTITION PANEL
(Not applicable to Premium 326 and 326X models)

- Install the left partition panel to left trolleyside panel and trolley rear panel.
- Install the left partition panel bracket between partition panel and trolley bottom shelf.

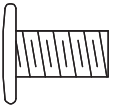

Phillips flat-head screw 1/4" x 1/2"
Qty: 7

NOTE: For Premium 529 model, four (4) screws to assemble partition panel to the trolley panels are stainless steel.

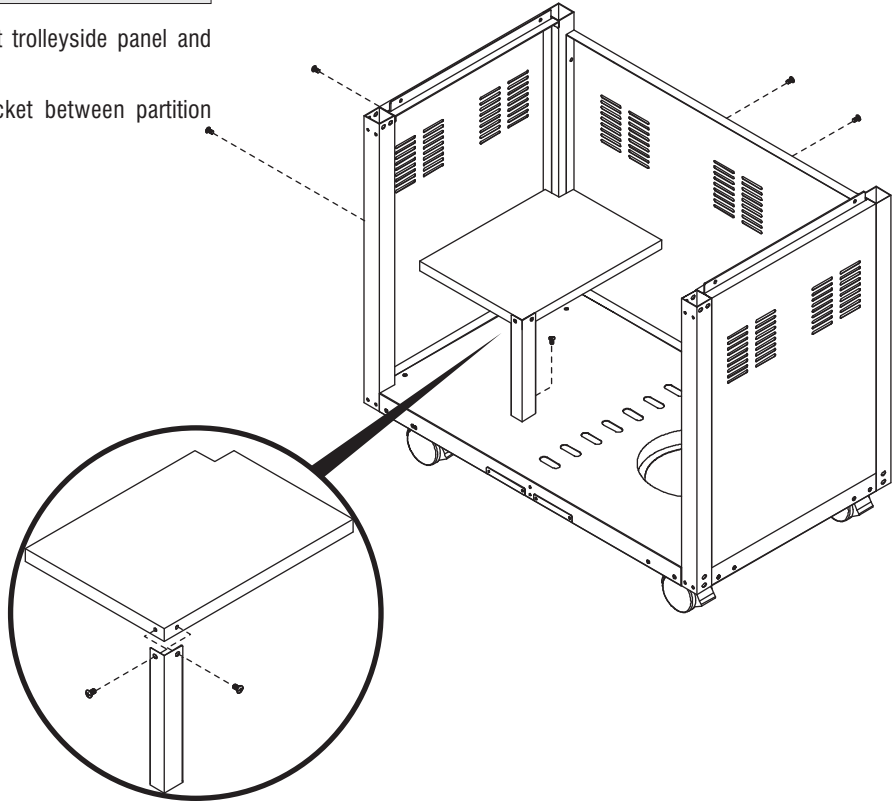

INSTALL TROLLEY BRACKET

- Install the trolley bracket in the up position (*part is labelled 'UP' to ensure proper assembly*) between front trolley legs as shown.

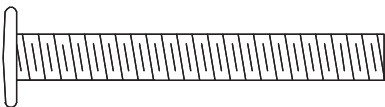

Phillips flat-head screw 1/4" x 2"
Qty: 4

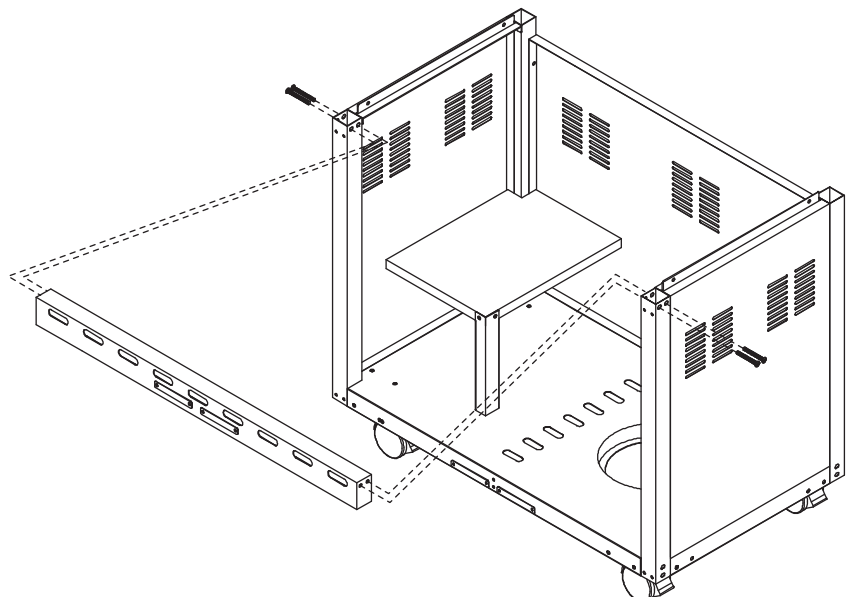

INSTALL DOORS

- Install the door handle to right door.
- Install the right bottom door hinge bracket to right trolley leg.
- Insert right door bottom post into right bottom door hinge bracket.
- Hold the right door and install the right top door hinge bracket to right trolley leg.
- Repeat for left door.
- Install the door guide plate to trolley bottom shelf.

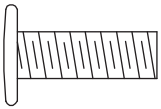
*Door handles*

Phillips flat-head screw 1/4" x 3/4"

Qty: 4

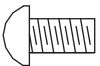
*Door hinges, guide plate*

Phillips-head screw 3/16" x 3/8"

Qty: 10

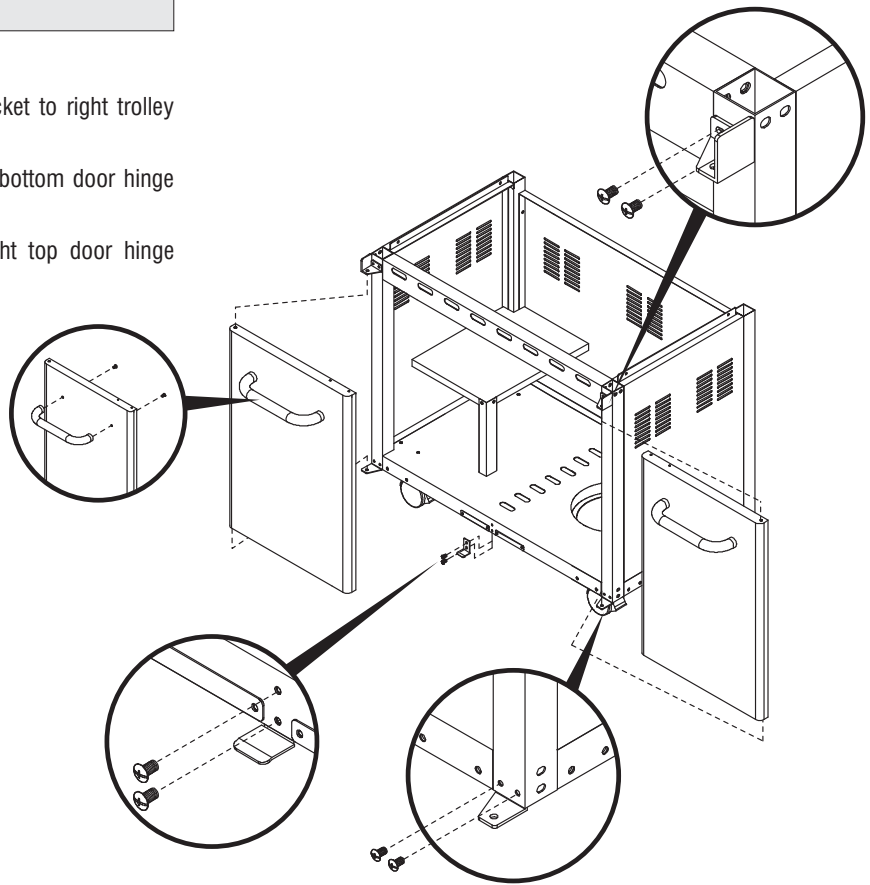
**INSTALL BARBECUE HEAD**

- Remove cooking components from barbecue head. With an assistant, lift and position barbecue head on the trolley.
- Tighten securely using screws.
- Attach the lighting stick to the left body panel.

*Lighting stick to barbecue body*

Phillips-head screw M4 x 8 mm

Qty: 1

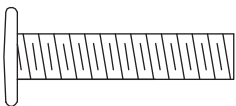
*Barbecue head to trolley*

Phillips flat-head screw 1/4" x 1 3/16"

Qty: 4

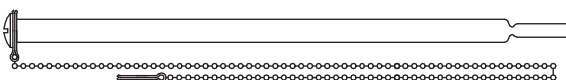
*Lighting stick*

Qty: 1

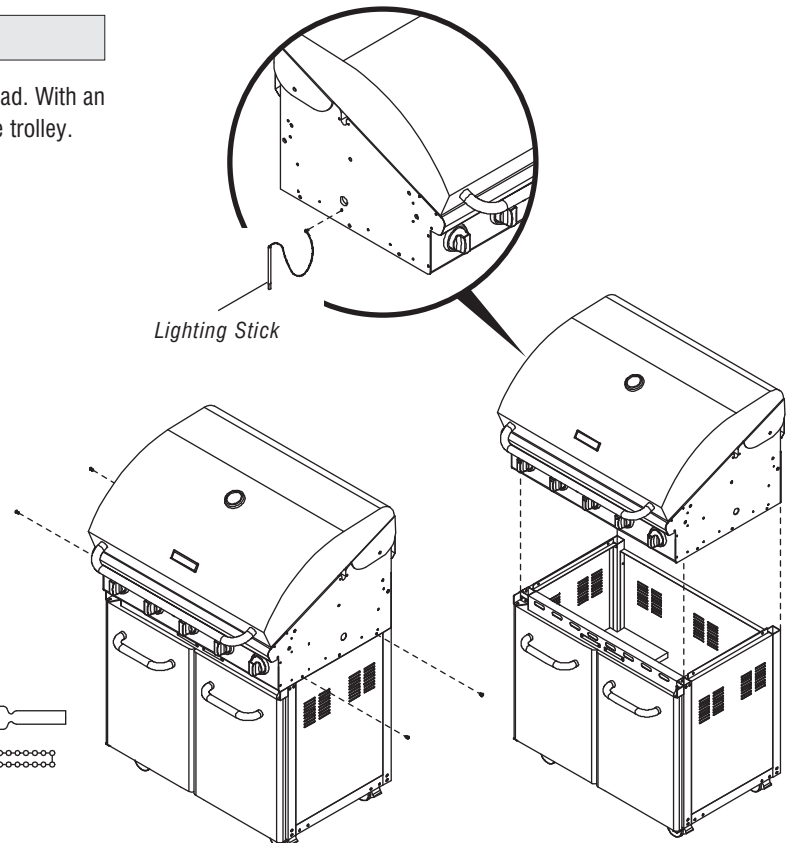

**INSTALL SIDE SHELF AND
SIDE BURNER FRAME**
(Premium 326X model has two side shelves)

- Remove screws from the tool holder. Slide the four (4) tool hooks onto the tool holder with the hooks facing the left side shelf. Attach tool holder to side shelf using these screws.
- Align the two (2) holes on front and rear body panels and three (3) holes on left body panel with the threaded holes on left side shelf. Insert the three (3) screws from the inside of the barbecue body and tighten securely.
- Align the two (2) holes on under side of left side shelf with the threaded holes on left body panel. Insert the two (2) screws and tighten securely.
- Repeat for right side burner frame (*right side shelf*).

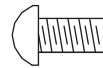

Tool holder to side shelf
Phillips-head screw
M5 x 8 mm

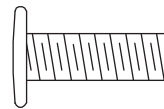

Side shelves / side burner to
barbecue head
Phillips flat-head screw
1/4" x 3/4"
Qty: 10

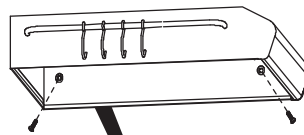
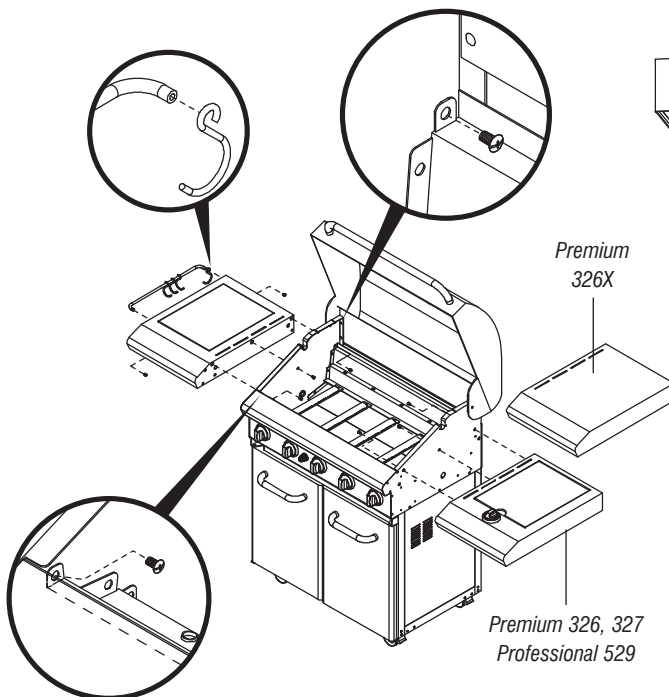

Inner side view of
left side shelf

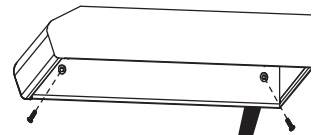

Inner side view of
right side burner
frame

NOTE: For Premium 326X model the side shelves may also be installed to the Premium Range and Premium Sink / Workstation modules. Refer to the appropriate instructions supplied with the modules.

CONNECT SIDE BURNER GAS VALVE

Premium 327 model, Professional 329 model

NOTE: Remove plastic protection sleeve from male fitting before connecting side burner hose.

- Position hose socket over valve plug. See diagram A.
- Pull and hold back socket sleeve.
- Push socket to right until it firmly snaps into place over plug. See diagram B.
- Push sleeve to right until it fully snaps into place. See diagram C.
- Give hose a tug to left to insure connection is secure.

WARNING: Failure to securely connect hose socket to valve plug may result in gas leaks which can cause fire or explosion.

Premium 326 model

Using a spanner connect the free end of the factory-fitted gas hose to the side burner to the manifold inlet. Refer to page 4 for 'Leak Test Procedure'.

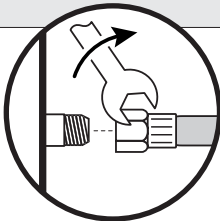

ASSEMBLE AND INSTALL GREASE DRAINING TRAY

- Remove plastic shipping bands attaching regulator to burner.
- Place the heat shield into grease draining tray making sure to fit the heat shield tabs into the slots in the base of the tray.
- From the back of the barbecue, slide the assembled tray side tabs over the side rails underneath the barbecue head.
- Install grease receptacle under the grease draining tray from the front of barbecue.

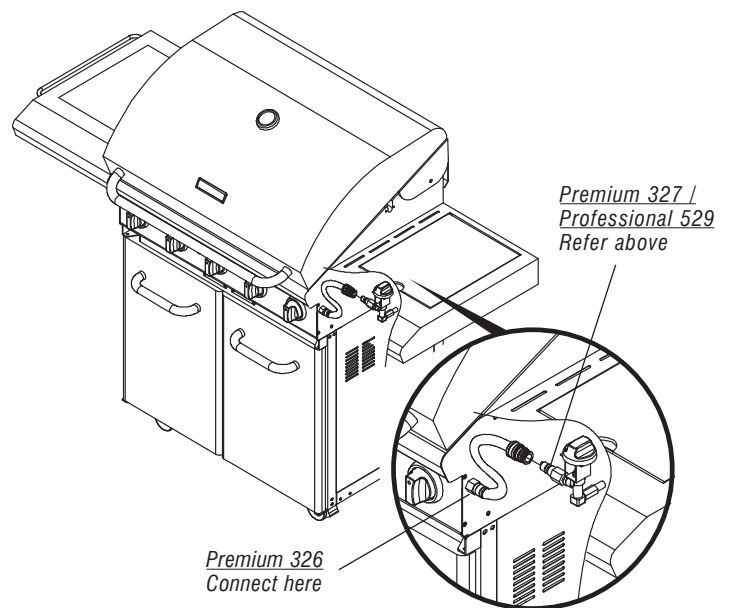
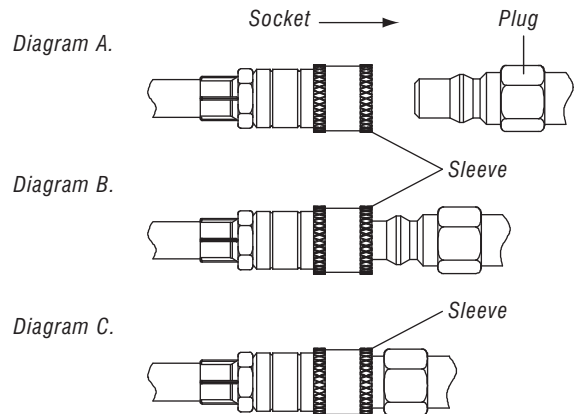
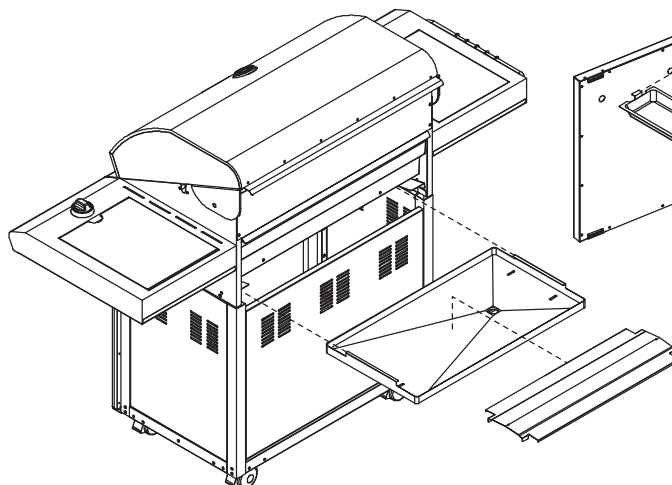

INSTALL SIDE SHELVES
- Professional 584 model

- Remove screws from the tool holder. Slide the four (4) tool hooks onto the tool holder with the hooks facing the left side shelf. Attach tool holder to side shelf using these screws.
- Align the two (2) holes on front and rear body panels and three (3) holes on left body panel with the threaded holes on left side shelf. Insert three (3) screws from the inside of the barbecue body, and tighten securely.
- Align the two (2) holes on under side of left side shelf with the threaded holes on left body panel. Tighten securely using two (2) screws.
- Align the five (5) holes on under side of right side shelf with the threaded holes on right outside body panel. Tighten securely using five (5) screws.

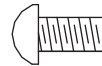

Tool holder to side shelf
 Phillips-head screw
 M5 x 8 mm
 Qty: 2

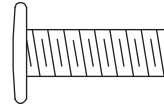

Side shelves / side burner to barbecue head
 Phillips flat-head screw
 1/4" x 3/4"
 Qty: 10

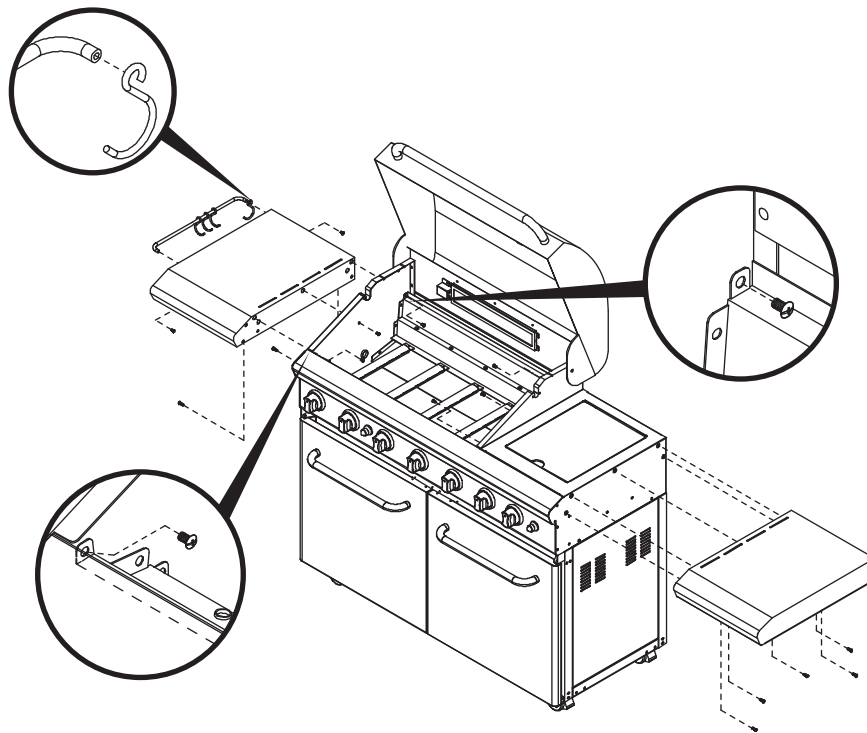

INSTALL IGNITER BATTERIES

- Unscrew igniter cap from control panel.
- Place supplied AA battery into the igniter slot with positive pole facing you.
- Position the cap and spring over the AA battery and tighten onto control panel.

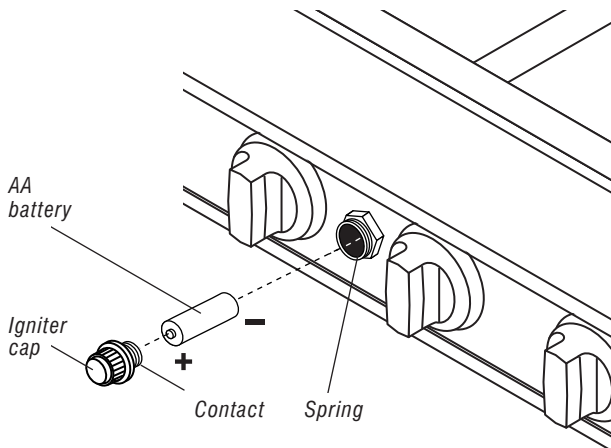

WITH THE ASSISTANCE OF ANOTHER PERSON, PERFORM THIS ELECTRODE CHECK BEFORE PROCEEDING

This test will ensure that the spark electrode tips are properly positioned so your barbecue lights easily and properly.

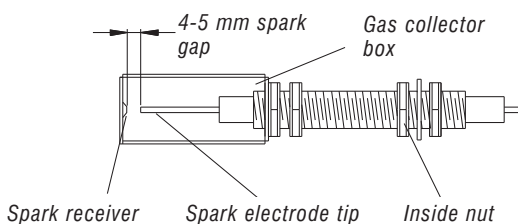

Ensure the gas source is turned off – or is disconnected and all burner control knobs are set to 'OFF' – and open the lids / side shelves.

Have your assistant stand behind to the right of the barbecue and look toward the front of the barbecue. Never put your face inside the barbecue.

Press the igniter cap or turn 'IGN'. You should hear a 'clicking' sound. Your assistant should see a blue spark within each gas collector box. If a spark is present the electrode tips are properly positioned.

If no spark is seen, the spark gap needs to be adjusted as follows:

- Using an adjustable spanner, loosen the inside nut until the gas collector box can be turned upward. If the gap between the spark electrode tip and receiver is more than 4 - 5 mm use long nose pliers to gently squeeze the gas collector box to narrow gap. Return the gas collector box to its original position, secure the inside nut and try the electrode check again.

If no 'clicking' sound is heard:

- AA battery may be installed backwards.
- Electronic wires may be loose. Remove the AA battery and inspect the igniter junction box found behind the control panel and reconnect any loose wires.



- **CHECK PERFORMANCE OF BURNERS PRIOR TO INSTALLING BARBECUE PLATE COMPONENTRY. Refer pages 24, 25 for lighting instructions**
- **DO NOT SMOKE WHEN ATTEMPTING TO IGNITE BARBECUE**
- **NEVER USE VOLCANIC ROCK, HEAT BEADS OR OTHER MATERIAL**
- **ALWAYS USE PROTECTIVE GLOVES WHEN HANDLING HOT COMPONENTS.**

SIDE BURNER ELECTRODE CHECK

- Open side burner lid. Remove plastic shipping band from burner and pot support.
- Push and turn side burner control knob to 'HI' or 'IGN'. Look for spark between tip of electrode and burner.
- If you don't see a spark from side burner electrode, adjust gap between electrode and burner surface to 4 - 5 mm.

INSTALL COOKING COMPONENTS

- Place the flame tamer on lower ledge above burners and under the grill plates.
- Place grill plates and hot plates on body ledge.
- Place the secondary cooking / warming rack into the slots on barbecue body side panels.



THIS APPLIANCE IS NOT DESIGNED FOR THE ENTIRE COOKING SURFACE TO BE COVERED WITH SOLID PLATES. A HAZARDOUS SITUATION MAY BE CREATED WHEREBY BURNERS MAY BEGIN TO BURN TOXIC GASES, OR EVEN GO OUT.

NOTE: For models 326, 326X, 327, 329 and 584 it is possible to use a maximum of two hot plates.

Premium 321S, 323, 325 models

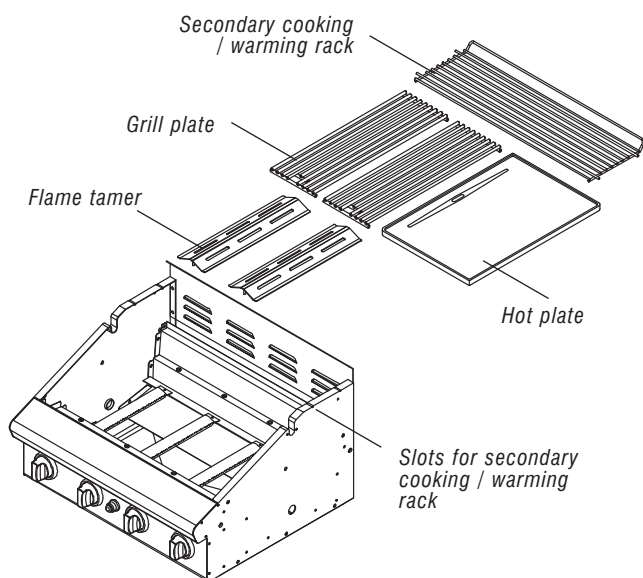

Professional 584 model

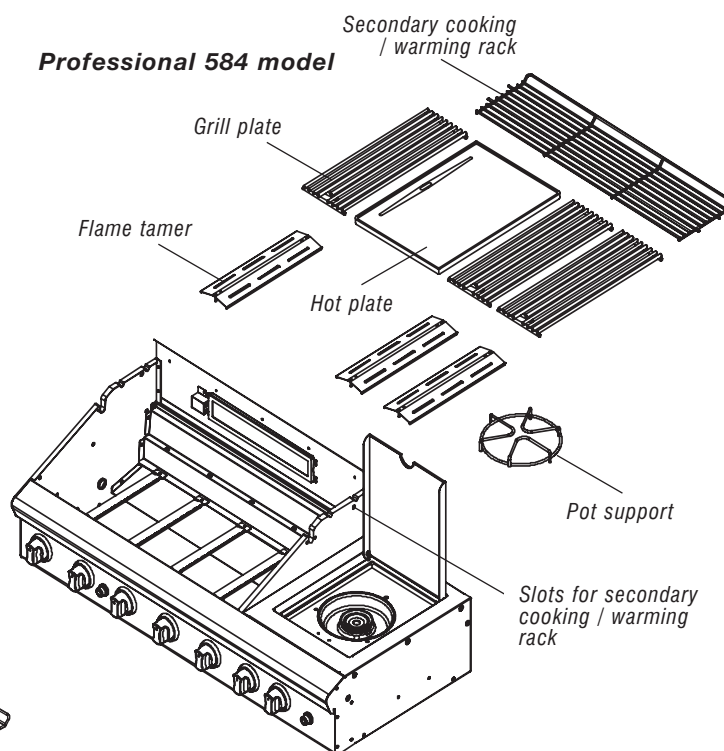

Premium 326, 326X, 327 and Professional 529 models

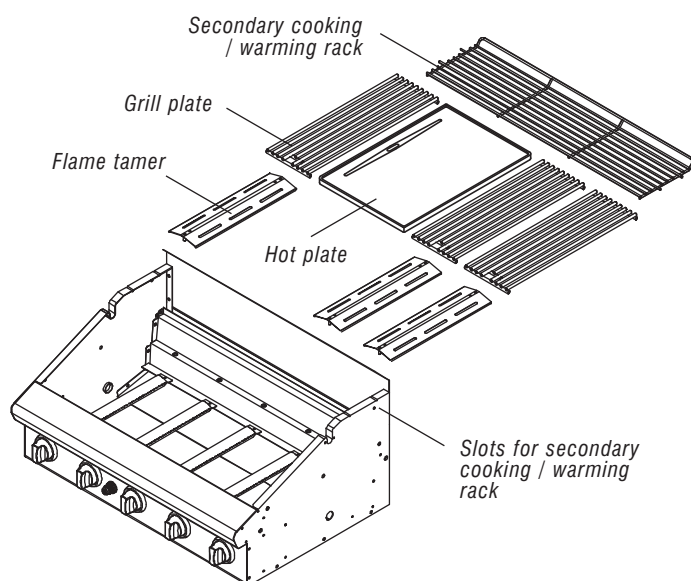

FINAL ASSEMBLY STEP

When you have finished assembling your barbecue be sure that all screws are tightened for safe operation of your barbecue.

IMPORTANT: Wash all stainless steel surfaces with mild detergent and warm water to remove any processing oils. Rinse with clean cold water then dry. Do not use any abrasive cleaners or cloths that may scratch the surface.

NOW YOUR BARBECUE IS READY TO USE

Before first use:

1. Please read 'Safety', 'Lighting' and 'Operating' instructions carefully.
2. Check and ensure the gas cylinder is full.
3. Ensure all connections are securely tightened. Check for gas leaks. Refer to page 4.

At the beginning of each barbecue season:

1. Check gas valve orifices, burner tubes and burner ports for any obstructions. eg. spiders, webs, insects.



- CONTENTS OF GREASE DRAINING TRAY AND GREASE RECEPTACLE MAY BE VERY HOT DURING COOKING
- ALLOW TO COOL COMPLETELY BEFORE DISPOSING OF THE CONTENTS
- AFTER CONTINUOUS USE, FAT AND/OR COOKING JUICES MAY BUILD UP. TO AVOID ANY FLARE-UPS, IT IS RECOMMENDED THAT THE GREASE TRAY AND RECEPTACLE BE EMPTIED REGULARLY
- GREASE / FAT FIRES ARE NOT COVERED BY WARRANTY.



- HOOD AND LIDS MUST BE IN THE OPEN POSITION FOR LIGHTING
- DO NOT SMOKE AT ANY TIME WHEN ATTEMPTING TO IGNITE BARBECUE
- CAUTION: DO NOT MOVE TROLLEY WHILE BARBECUE IS IN OPERATION
- NEVER LEAN OVER THE BARBECUE COOKING AREA WHILE LIGHTING THE APPLIANCE
- KEEP YOUR FACE AND BODY AT A SAFE DISTANCE (AT LEAST 450 mm) FROM THE MANUAL LIGHTING HOLE OR BURNERS
- CAUTION: DO NOT LEAVE THE BARBECUE UNATTENDED WHEN BURNER/S IS ALIGHT.

CONNECTING TO, AND DISCONNECTING FROM GAS SOURCE

Familiarise yourself with the general information and safety guidelines located at the front of this booklet. Check to see that gas cylinder is filled and that end of each burner tube is properly located over each valve orifice. Set burner controls to 'OFF' position.

ENSURING BURNER CONTROLS ARE OFF

IMPORTANT: Before connecting and disconnecting barbecue to gas source, ensure burner controls are in 'OFF' position.

NOTE: The 'OFF' position on the control panel is identified by either a small black dot / a short vertical black line / or the word 'OFF'.

When the marking, or the word 'OFF' printed on the control knob, aligns with the printed marking on the control panel, then the burner is in the fully off position.

CAUTION: When the appliance is not in use, the gas must be turned off at the gas cylinder.



TEST FOR LEAKS WITH A LIQUID DETERGENT SOLUTION, NEVER WITH AN OPEN FLAME (Refer to page 4)



- DISCONNECT AND REMOVE GAS CYLINDER WHEN MANOEUVRING THE BARBECUE OVER UNEVEN SURFACES OR CARRYING UP AND DOWN STAIRS
- IF THIS INFORMATION IS NOT FOLLOWED EXACTLY, A FIRE CAUSING DEATH OR SERIOUS INJURY MAY OCCUR!
- DO NOT STORE A SPARE GAS CYLINDER UNDER OR NEAR THIS APPLIANCE
- THIS BARBECUE IS ONLY TO BE USED OUTDOORS.

CONNECTING TO GAS SOURCE

1. Screw the wing bolt and special nut to trolley bottom shelf or gas cylinder pull-out tray.

NOTE: The special nut may be omitted for gas cylinders with larger bases.

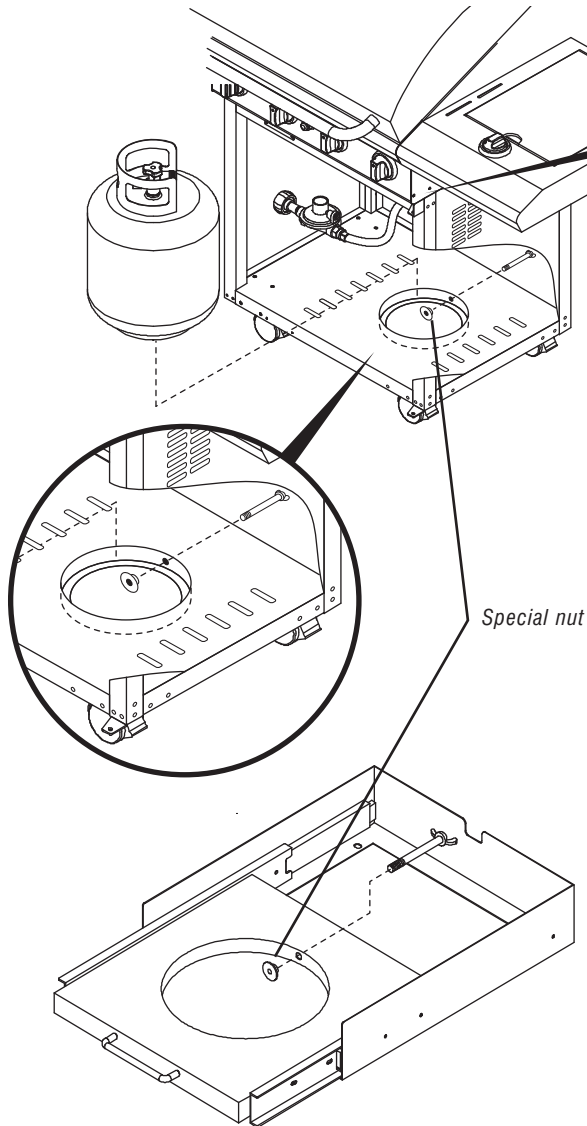

2. Secure the gas hose to the trolley bracket front with hook supplied.

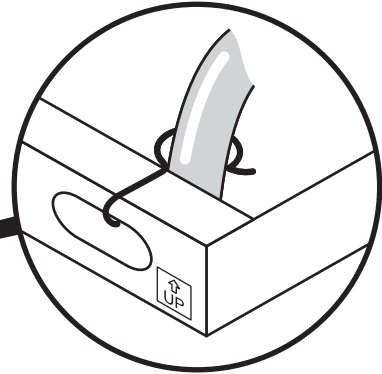

3. Place the gas cylinder on the ground in front of the barbecue or on the gas cylinder pull-out tray (extended position).

4. Attach cylinder connection device of regulator and hose assembly to cylinder valve outlet.

Tighten firmly.

5. Open the gas cylinder valve 1/4 to 1/2 open to allow gas to flow.

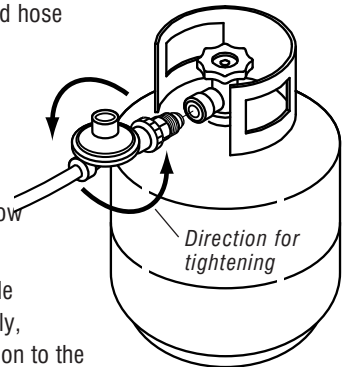

6. Leak test all accessible connections thoroughly, including the connection to the gas cylinder, using a liquid detergent water solution prior to lighting the barbecue. Refer to 'Safety' information, pages 3 - 5.
7. If a leak is found, turn gas cylinder valve off and do not use barbecue until repairs or replacement can be made.
8. Install the gas cylinder into the trolley so that the cylinder valve faces to the front.
9. Secure the gas cylinder with the wing bolt.

DISCONNECTING FROM GAS SOURCE

1. Turn the burner control 'OFF'.
2. Turn the gas cylinder valve off fully.
3. Detach the regulator assembly from gas cylinder valve. Protect the connection end of the regulator from damage.

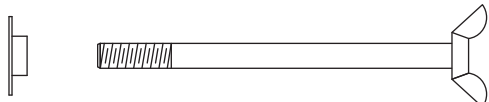
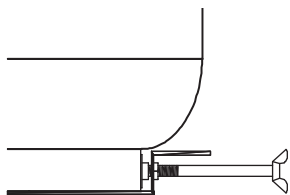

Special nut 1/4"
Qty: 1

Wing bolt 1/4" x 6 11/16"
Qty: 1



LOUVRES ON BARBECUE MUST REMAIN UNOBSTRUCTED TO ALLOW FOR COMBUSTION AIR.

ACCESS MUST BE PROVIDED TO SHUT-OFF VALVE.



CAUTION: DO NOT LEAVE THE BARBECUE UNATTENDED WHEN BURNER/S IS ALIGHT.



ANY OF THE FOLLOWING SIGNS MAY INDICATE THAT THE APPLIANCE IS NOT OPERATING PROPERLY AND MAY NEED SERVICING:

- **EXCESSIVE YELLOW FLAME**
- **IRREGULAR SIZE OF FLAME ACROSS BURNER**
- **'POPPING' OF FLAME**
- **SOOTING**
- **ABNORMAL NOISE(S)**
- **HISSING SOUND**

NOTE: Before requesting service, please refer to page 28 'If Barbecue Fails to Operate'



CAUTION: IF BURNERS GO OUT DURING OPERATION, CLOSE GAS SUPPLY AT SOURCE, AND TURN ALL BURNER CONTROL KNOBS OFF.

OPEN HOOD AND WAIT 5 MINUTES BEFORE RE-ATTEMPTING TO LIGHT (ENSURE ACCUMULATED GAS FUMES HAVE CLEARED).

CAUTION: SHOULD A GREASE FIRE OCCUR, ATTEMPT TO CLOSE GAS SUPPLY AT SOURCE, TURN OFF ALL BURNERS AND REMOVE FOOD IF POSSIBLE.

KEEP THE VENTILATION OPENINGS OF THE CYLINDER ENCLOSURE FREE AND CLEAR FROM DEBRIS.



THE SIDE BURNER IS DESIGNED FOR USE WITH A WOK UP TO 360 mm DIAMETER, AND COOKING PAN OF UP TO 200 mm DIAMETER.

USE OF VERY LARGE POTS MAY RESULT IN DISCOLOURATION OF THE SURFACE FINISH, OR CAUSE POOR COMBUSTION.



• **FAILURE TO REPLACE A FAULTY HOSE, SECURE GAS SUPPLY CONNECTIONS OR TO OPEN THE HOOD BEFORE PROCEEDING TO THE LIGHTING PROCEDURES COULD RESULT IN A FIRE OR EXPLOSION THAT COULD CAUSE SERIOUS BODILY INJURY, DEATH, OR PROPERTY DAMAGE**

• **NEVER LEAN OVER THE BARBECUE COOKING AREA WHILE LIGHTING YOUR GAS BARBECUE. KEEP YOUR FACE AND BODY A SAFE DISTANCE (AT LEAST 450 mm) FROM THE LIGHTING HOLE OR BURNERS WHEN LIGHTING YOUR BARBECUE BY MATCH.**

PRE-OPERATING PROCEDURE

BURN-OFF

Before cooking on your barbecue for the first time, burn-off any residual oils or foreign matter from the cooking plates.

ENSURE THE HOOD IS OPEN, and operate at 'HI' setting for approximately 15 minutes. Allow to cool then wash grill plates/hot plate thoroughly with soap suds and scrubbing brush. Rinse thoroughly and wipe clean with a cloth.

PREHEATING

It is necessary to preheat the barbecue before cooking. Operate the burners under the cooking surface to be used at 'HI' for approximately 10 minutes before cooking. Hooded barbecues should be pre-heated with the hood down.

COOKING TEMPERATURES – Main burners

'HI' setting – Use this setting only for warm up, for searing steaks and chops, and for burning food residue from the plates after the cooking is over. Rarely, if ever, do you use the 'HI' setting for extended cooking.

'MED' setting (*mid-way between 'HI' and 'LOW'*). Use this setting for most grilling, and for cooking hamburgers and vegetables.

'LOW' setting – Use this setting when cooking very lean cuts such as fish.

Actual cooking surface temperatures vary with outside temperature and the wind conditions.

LIGHTING PROCEDURE

- Premium 321S, 323, 325, 326, 326X,
Professional 529

MAIN BURNER

1. Before each use, check all hoses for cracks, nicks, cuts, burns or abrasions. If a hose is damaged in any way, do not use your barbecue before replacing the hose with an authorised part from the 'Parts List'. Also make sure all gas supply connections are securely tightened.
2. Familiarise yourself with the 'Safety', pages 3-5, and 'Maintenance', pages 29-31, in this manual. Do not smoke while lighting barbecue or checking gas supply connections.
3. Ensure the gas cylinder is filled.
4. Open the barbecue hood.
5. Set control knobs to 'OFF' and open the LP gas cylinder valve to 1/4 - 1/2 open.



6. Push and turn the required control knob to 'HI'.

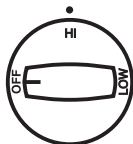

7. Immediately press the electronic igniter to light the burner.

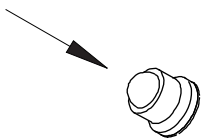

9. If ignition does not occur in 15 seconds, turn the burner control knob(s) and gas source off and conduct a leak test of ALL gas connections and gas source. If no leaks are detected, wait 5 minutes for any gas to clear and repeat the lighting procedure.
10. Once one burner is lit, the adjacent burner can be lit by turning its control knob to 'HI'.

SIDE BURNER

Lid must be open before lighting. For easy ignition, push the burner control in fully. Slowly rotate the burner control anti-clockwise through 90 degrees (approx. 3 - 4 seconds). Turn the burner control until a click is heard, this will trigger the piezo, producing a spark at the burner.

The 3 - 4 second duration should provide enough gas to light the burner. If the burner does not light, immediately return the burner control to the 'OFF' position and repeat the process.

Turn burner control to 'HI' following lighting procedure until flame appears on the burner. If for some reason the igniter fails to produce a spark at the electrode tip, the burner can be lit using a match.

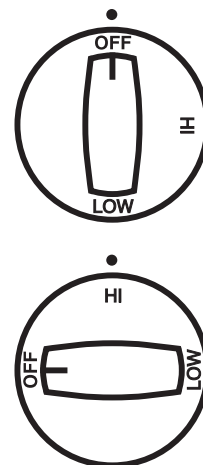
**MANUAL LIGHTING**

To light your gas barbecue by match, insert a match into the lighting stick and follow steps 1 through 6 of the barbecue lighting instructions. Then, light the match and place lighting stick through the lighting hole on the left side of the barbecue, as shown below. Turn the nearest control knob to the 'HI' setting to release gas. The burner should light immediately.

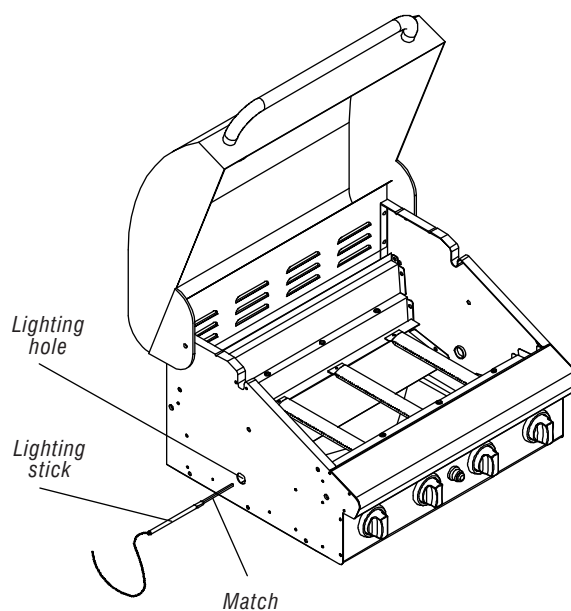

LIGHTING PROCEDURE – Professional 584 model

MAIN BURNER

1. Before each use, check all hoses for cracks, nicks, cuts, burns or abrasions. If a hose is damaged in any way, do not use your barbecue before replacing the hose with an authorised part from the 'Parts List'. Also make sure all gas supply connections are securely tightened.
2. Familiarise yourself with the 'Safety' pages 3 - 5 and 'Maintenance' pages 27 - 29 instructions in this manual. Do not smoke while lighting barbecue or checking gas supply connections.
3. Be sure the gas cylinder is filled or the natural gas line is attached to the gas source.
4. Open the barbecue hood.
5. Set control knobs to 'OFF' and open the LP gas cylinder valve to 1/4 to 1/2 open. For natural gas open the shut-off valve at source.

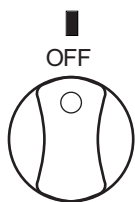

Open
LP gas
cylinder

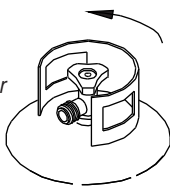

6. Push and turn the required control knob to 'IGN'. Push the control knob in to automatically ignite the burner.

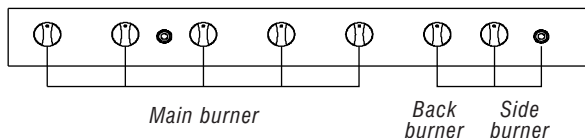
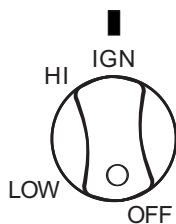

7. If ignition does not occur in 15 seconds, turn the burner control knob(s) and gas source off and conduct a leak test of ALL gas connections and gas sources. If no leaks are detected, wait five (5) minutes for any gas to clear and repeat the lighting procedure.
8. Once one burner is lit, the adjacent burner can be lit by turning its control knob to 'HI'.

BACK BURNER

1. Follow steps 1 through 6 of the 'Barbecue Lighting' instructions.
2. Push and turn the control knob to 'IGN'. Push the control knob in to automatically ignite the burner. Once the burner is lit, turn the knob back to 'ON', keep pressing the knob and holding it for at least 10 seconds before releasing.
3. If ignition does not occur in fifteen (15) seconds, turn the control knob(s) and gas source off and conduct a leak test. If no leaks are detected, wait five (5) minutes for any gas to clear and repeat the lighting procedure.

Back burner knob

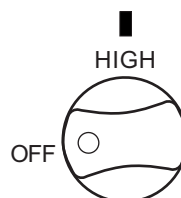

Side burner knob

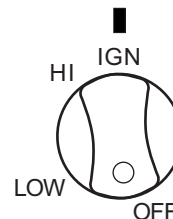

SIDE BURNER

1. Follow steps 1 through 6 of the 'Barbecue Lighting' instructions.
2. Open side burner lid.
3. Push and turn the control knob to 'IGN'. Push the control knob in to automatically ignite the burner. Once the burner is lit, turn the knob back to 'HI'.
4. If ignition does not occur in fifteen (15) seconds, turn the burner control knob(s) and gas source off and conduct a leak test as explained in the 'Use and Care' section of this manual. If no leaks are detected, wait five (5) minutes for any gas to clear and repeat the lighting procedure.

MANUAL LIGHTING

To light your main burner by match, follow steps 1 through 6 of the barbecue lighting instructions. Then, light the match and place it over the top opening of the lighting tube. Push and turn the nearest control knob to the 'HI' setting to release gas. The burner should light immediately.

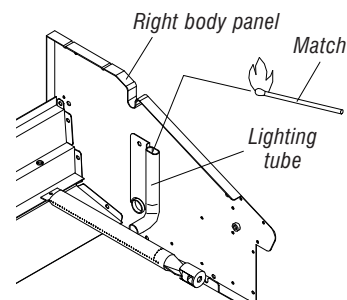

COOKING WITH THE HOOD DOWN

Cooking with the hood in the closed position helps to cook food more quickly than in conventional barbecues with a simple lid. The hood (*when closed*) helps to retain the heat more evenly and conserves energy.

IMPORTANT: *Never use any burner or combination of burners on 'HI' for extended periods when cooking with the hood down.*

High direct heat when the hood is down may result in burnt food, or damage to painted surfaces.

When roasting in your barbecue, food should be positioned over the centre burners either on a roasting rack with the cooking pan underneath, or directly in the cooking pan, or placed in a disposable aluminium foil dish on top of a flame tamer. Although all burners may be used, it is advisable not to use the burners directly under the food being cooked as this may result in burnt and spoiled food. Remove other grill plate and hot plate not being used.

The heat from the selected burners circulates gently throughout the barbecue, cooking the meat or poultry without any direct flame touching it. This method greatly reduces flare-ups when cooking extra fatty cuts, because there is no direct flame to ignite the fats and juices that drip during cooking. Regulate the lit burners between 'LOW' and 'MED'. Do not exceed 250°C.

If the temperature exceeds 250°C with burners set at 'LOW' turn some off to reduce the cooking temperature. Operating the barbecue at high temperatures may cause damage to components and surface finishes.

COOKING WITH THE HOOD OPEN

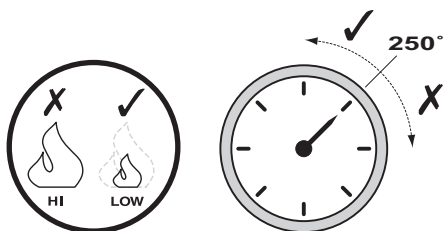
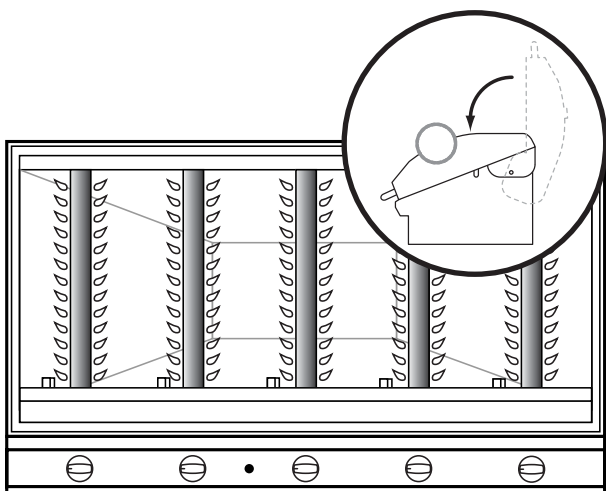
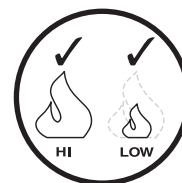
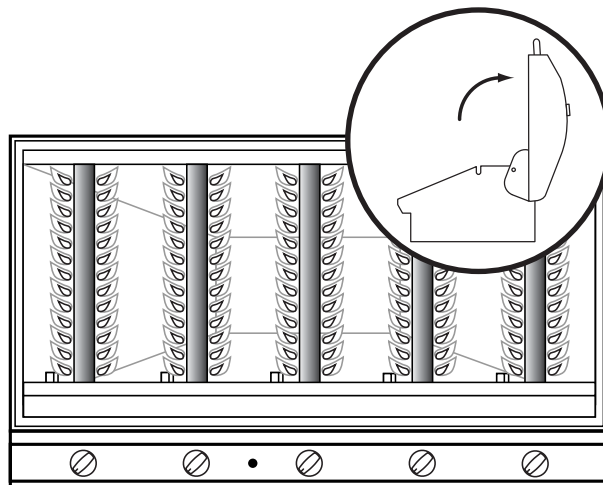

ROTISSERIE

NOTE: The following information is relevant whether rotisserie cooking with a back burner or using the indirect method – refer 'Cooking With The Hood Down' on page 26.

When cooking using the back burner, extra heat can be achieved by using the main burners. It is recommended to use only the outside burners on 'LOW' setting. Do not exceed 250°C cooking temperature.

Rotisserie is available as an optional extra from your place of purchase.

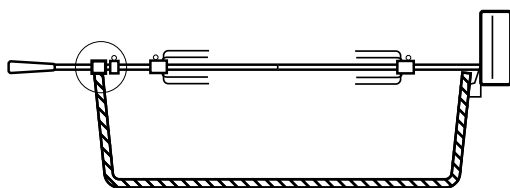

SAFETY POINTS

- Do not operate damaged rotisserie.
- Do not use rotisserie in poor weather conditions.
- Avoid contact with hot surfaces.
- Always load rotisserie to barbecue before switching motor on.
- Always turn rotisserie 'OFF' before removing from barbecue.
- Do not leave rotisserie on barbecue when not in use.

LOADING THE SPIT RODS

- Assemble rotisserie rod as shown.
- Centre food on the spit rod.
- Use butcher string to secure loose portions.

ROTISSERIE COOKING

- Rotisserie cooking produces foods that are moist, flavoursome and appealing. The rotating food self bastes. Although the rotisserie is best for larger pieces of meat or poultry, most cuts can be used if prepared properly.
- The balancing of the food requires the most attention in rotisserie cooking. The rotisserie must turn evenly otherwise the stopping and starting action will cause the food to cook unevenly and possibly burn the heavier side. Refer to the diagram below.

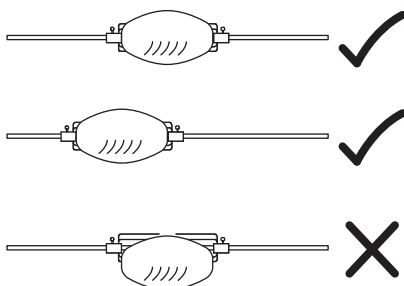

- The easiest foods to balance are those of uniform shape and texture. To test if the food is balanced correctly when secured, place the ends of the rotisserie skewer loosely in the palm of your hands. Give the spit a quarter turn and if there is no tendency to roll and it is stable give it another quarter turn. It should rest without turning in each of these positions.

It can then be attached to the barbecue.

- When using poultry, truss the bird tightly so that wings and drumsticks are close to the body of the bird. The cavity of the bird can be stuffed prior to this, if you wish. Pull the neck skin down and using a small skewer fix to the back of the bird. Push the rotisserie skewer through lengthwise, catching the bird in the fork of the wishbone. Centre the meat and tighten the holding forks. Test the balance as described above.
- A rolled piece of meat only requires the rotisserie skewer to be inserted through the centre of the length of meat, then secured and balanced using the forks.
- For meats which are un-boned, it is best to secure the rotisserie skewer diagonally through the meaty sections. If protruding bones or wings brown too quickly, cover with pieces of foil.

SETTING UP THE BARBECUE

- Remove all the cooking plates from the barbecue and position the flame tamer centrally. Place either an oven proof cooking pan or disposable aluminium foil dish on top of the flame tamer under the food being cooked so that it catch any drips from the food above. The drippings can be used to make gravies and other sauces to accompany the cooked meat.
- Once the barbecue has been set up, pre-heat the barbecue according to the manufacturer instructions. Close the hood when you start to cook.
- For foods with little fat you may wish to cook them directly over lit burners to give a charred effect. This should only be done towards the end of the cooking for no longer than the time required to give the desired visual effect. Do not attempt this with fatty foods as this will cause flare-ups and excessive smoke.

COOKING TIMES

- This will vary according to the type and weight of food you are cooking. However as a guide the cooking times on a rotisserie are similar to conventional oven cooking.

IF THE BARBECUE FAILS TO LIGHT

1. Turn gas off at source and turn burner control knobs to 'OFF'. Wait at least five (5) minutes for gas to clear, then retry.
2. If your barbecue still fails to light, check gas supply and connections.
3. Repeat lighting procedure. If your barbecue still fails to operate, turn the gas off at source, turn the control knobs to 'OFF', then check the following:
 - **Misalignment of burner tubes over orifices**
Correction: Reposition burner tubes over orifices.
 - **Obstruction in gas line**
Correction: Remove fuel line from barbecue. Do not smoke! Open gas supply for one second to clear any obstruction from fuel line. Close off gas supply at source and reconnect fuel line to barbecue.
 - **Plugged orifice**
Correction: Remove burners from barbecue by pulling cotter pin (beneath burner) using long nose pliers. Carefully lift each burner up and away from gas valve orifice. Remove the orifice from gas valve and gently clear any obstruction with a fine wire. Then reinstall all orifices, burners, cotter pins and cooking components.

If an obstruction is suspected in gas valves or manifold, contact your place of purchase or manufacture.
 - **Obstruction in burner tubes**
Correction: Follow the burner tube cleaning procedure on page 31 of this operator's manual.
 - **Misalignment of igniter on burner**
Correction: Check for proper position of the electrode tip as shown on page 19. The gap between the spark electrode tip and spark receiver should be approximately 4 - 5 mm. Adjust if necessary. With the gas supply closed and all control knobs set to 'OFF' press the electronic igniter cap and check for the presence of a spark at the electrode.
 - **Disconnected electronic wires**
Correction: Inspect the igniter junction box found behind the control panel. Connect loose electronic wires to junction box and try to light the barbecue.
 - **Weak AA battery**
Correction: Unscrew the igniter cap and replace the battery.



- **SHOULD A FLASHBACK FIRE OCCUR IN OR AROUND THE BURNER TUBES, FOLLOW THE INSTRUCTIONS BELOW. FAILURE TO COMPLY WITH THESE INSTRUCTIONS COULD RESULT IN A FIRE OR EXPLOSION THAT COULD CAUSE SERIOUS BODILY INJURY, DEATH, OR PROPERTY DAMAGE.**
- **SHUT OFF GAS SUPPLY TO THE GAS BARBECUE.**
- **TURN THE CONTROL KNOBS TO 'OFF' POSITION.**
- **OPEN THE BARBECUE LID. PUT OUT ANY FLAME WITH A FIRE EXTINGUISHER.**
- **ONCE THE BARBECUE HAS COOLED DOWN, CLEAN THE BURNER TUBES AND BURNERS ACCORDING TO THE CLEANING INSTRUCTIONS IN THIS OPERATOR'S MANUAL.**



DO NOT USE OVEN CLEANER TO CLEAN THE BARBECUE.

SOME PROPRIETARY BARBECUE CLEANERS MAY AFFECT / DAMAGE SOME OF THE SURFACE COATINGS USED ON THE APPLIANCE.

READ THE CLEANER INSTRUCTIONS CAREFULLY.

IT IS RECOMMENDED TO TEST IN AN INCONSPICUOUS PLACE FIRST.

GENERALLY WE RECOMMEND ONLY WARM SOAPY WATER FOR CLEANING THE APPLIANCE.



IN COASTAL AREAS, FREQUENT CLEANING AND THE USE OF A COVER IS RECOMMENDED TO PROLONG THE LIFE OF THE APPLIANCE. SALTY AIR WILL ADVERSELY AFFECT EXPOSED PARTS.

CLEANING AND MAINTENANCE

Proper care and maintenance will keep your barbecue in top operating condition and prolong its life. Follow these cleaning procedures on a timely basis and your barbecue will stay clean and operate with minimum effort.

CAUTION: Be sure your barbecue is off and cool before cleaning.

CLEANING THE COOKING PLATES

Before initial use, and periodically, wash your cooking plates in a mild soap and warm water solution. You can use a wash cloth or vegetable brush to clean your cooking plates.

It is recommended the cooking plates be coated with a thin layer of cooking oil on a regular basis to prevent rusting. Slight rusting can be removed with a scrubbing brush before use.

CLEANING THE FLAME TAMERS

Periodically you should wash the flame tamer in a soap and warm water solution. Use a vegetable brush to remove stubborn burnt-on cooking residue. Dry the flame tamers thoroughly before you re-install them into the barbecue.

CLEANING THE GREASE TRAY AND RECEPTACLE

To reduce the chance of fire, the grease draining tray and grease receptacle should be visually inspected before each barbecue use. Remove any grease and wash grease tray and receptacle with a mild soap and warm water solution.

NOTE: Grease / fat fires are not covered by warranty.

CLEANING EXTERIOR SURFACES

Before initial use, and periodically thereafter, we suggest you wash your barbecue using a mild soap and warm water solution. You can use a wash cloth or sponge for this process. Do not use a stiff wire or brass brush. These will scratch stainless steel and chip painted surfaces (*varies by model*) during the cleaning process.

CARE FOR STAINLESS STEEL

The stainless steel over time will be affected by 'tea staining' (*the brown discolouration of some stainless steel*).

Tea staining can be reduced by washing the surface with mild detergent and warm water. This should then be followed by rinsing with clean cold water. We recommend the surface then be wiped dry with a clean cloth.

STORAGE

We recommend that you minimise the barbecue's exposure to the elements. High moisture content in the air (*rain, mist, salt spray etc.*) can affect metal components and lead to material breakdown. If left in an area subjected to high moisture content, we strongly recommend that you observe the cleaning procedure on a regular basis and cover the appliance whilst not in use (*covers are available as an optional extra*). Material breakdown from high moisture conditions can be avoided if the appliance is well protected from the weather and regular cleaning is carried out.

ANNUAL CLEANING OF THE BARBECUE INTERIOR

Burning-off excess food after every cookout will keep it ready for instant use. However, at least every 3 months you must give the entire barbecue a thorough cleaning to minimise your risk of grease fire and keep the barbecue in top shape. *Follow these steps:*

1. Turn all burner valves to the full 'OFF' position.
2. Turn the LP gas cylinder valve to the full 'OFF' position.
3. Disconnect the regulator from the gas cylinder. Inspect the hose with regulator assembly for cracking, cuts or any other damage, and replace as necessary. *Refer to the separate Parts List.*
4. Remove and clean the flame tamers, cooking plates and barbecue burners.
5. Cover each gas valve orifice with aluminum foil.
6. Brush the inside and bottom of the barbecue with a fibre pad or nylon brush and wash with a mild soap and warm water solution. Rinse thoroughly and let dry.
7. Remove aluminum foil from orifices and check each orifice for obstruction.
8. Check each spark electrode, adjusting as needed. The space between the spark electrode tip and spark receiver should be approximately 4 - 5 mm.
9. Replace the burners and adjust the gas collector box. The edge of the collector box should be overlapping the burner port.
10. Reconnect the gas source and observe the burner flame for correct operation.
11. Replace flame tamers and cooking plates.



- **BEWARE OF SPIDERS. BURNER TUBES SHOULD BE INSPECTED AND CLEANED PERIODICALLY.**



- **SPIDERS AND SMALL INSECTS CAN OCCASIONALLY SPIN WEBS OR MAKE NESTS IN THE BURNER TUBES. THESE WEBS CAN LEAD TO A GAS FLOW OBSTRUCTION WHICH COULD RESULT IN A FIRE IN AND AROUND THE BURNER TUBES**
- **THIS TYPE OF FIRE IS KNOWN AS 'FLASH-BACK' AND CAN CAUSE SERIOUS DAMAGE TO YOUR BARBECUE AND CREATE AN UNSAFE OPERATING CONDITION FOR THE USER**
- **ALTHOUGH AN OBSTRUCTED BURNER TUBE IS NOT THE ONLY CAUSE OF 'FLASH-BACK' IT IS THE MOST COMMON CAUSE AND FREQUENT INSPECTION AND CLEANING OF THE BURNER TUBES IS NECESSARY.**



- **KEEP BARBECUE AREA CLEAR AND FREE FROM COMBUSTIBLE MATERIALS, GASOLINE AND OTHER FLAMMABLE VAPOURS AND LIQUIDS**
- **DO NOT OBSTRUCT THE FLOW OF AIR FOR COMBUSTION AND VENTILATION.**
- **KEEP THE VENTILATION OPENINGS OF THE CYLINDER ENCLOSURE CABINET FREE AND CLEAR OF DEBRIS**
- **VISUALLY CHECK BURNER FLAMES OCCASIONALLY TO ENSURE PROPER FLAME PATTERN AS SHOWN BELOW**
- **FAILURE TO COMPLY WITH THESE INSTRUCTIONS MAY RESULT IN A HAZARDOUS SITUATION WHICH, IF NOT AVOIDED, MAY RESULT IN INJURY.**



Magnified view of burner flame through lighting hole.

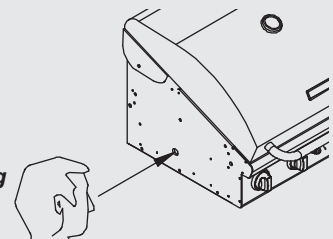

CLEANING THE BURNER TUBES AND BURNER PORTS

To reduce the chance of FLASHBACK FIRE you must clean the burner tubes as follows at least once a month in summer and fall or whenever spiders are active in your area, and if your barbecue has not been used for an extended period of time.

1. Turn all burner valves to the full 'OFF' position.
2. Turn the LP gas cylinder valve to the full 'OFF' position.
3. Detach the LP gas regulator assembly from your gas barbecue.
4. Remove the cooking plates, flame tamer plates and grease trays from your barbecue.
5. Remove the screw from the rear of each burner using a Phillips-head screwdriver.
6. Carefully lift each burner up and away from the gas valve orifice.
7. Check and clean burner/venturi tubes for insects and insect nests. A clogged tube can lead to a fire beneath the barbecue.
8. Refer to diagram 1 and perform one of these three cleaning methods:

METHOD 1: Bend a stiff wire or wire coat hanger into a small hook as shown and run the hook through the burner tube and inside the burner several times to remove debris.



METHOD 2: Use a bottle brush with a flexible handle and run the brush through the burner tube and inside the burner several times to remove any debris.

METHOD 3: Use an air hose to force air through each burner tube. The forced air should pass debris or obstructions through the burner and out the ports.

Regardless of which burner cleaning procedure you use, we recommend you also complete the following steps to help prolong burner life.

1. Use a fibre pad or nylon brush to clean the entire outer surface of each burner until free of food residue and dirt.
2. Clean any clogged ports with a stiff wire, such as an open paper clip.
3. Inspect each burner for damage (*cracks or holes*) and if such damage is found, order and install a new burner. After installation, check to ensure that the gas valve orifices are correctly placed inside the ends of the burner tubes. Also check the position of your spark electrode.



FOR SAFE OPERATION ENSURE THE GAS VALVE ASSEMBLY ORIFICE IS INSIDE THE BURNER TUBE BEFORE USING YOUR BARBECUE. See diagram. IF THE ORIFICE IS NOT INSIDE THE BURNER TUBE, LIGHTING THE BURNER MAY CAUSE EXPLOSION AND / OR FIRE RESULTING IN SERIOUS BODILY INJURY AND / OR PROPERTY DAMAGE.

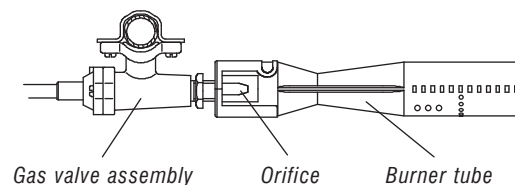
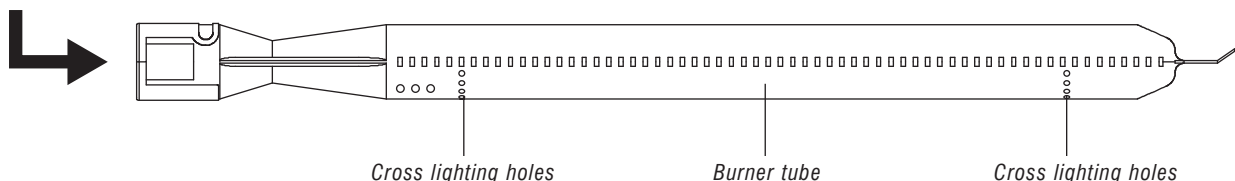

Diagram 1.

To clean burner tube, insert hook as indicated by the arrow.



BURNER IS TO BE INSTALLED WITH THE CROSS LIGHTING HOLES UNDERNEATH.

PRIVACY POLICY

Focus Lifestyle Products Pty Ltd may collect personal information about a consumer of its products in the course of receiving or responding to a warranty claim. Such information is only collected to enable the resolution of the warranty claim to the consumer's satisfaction, and is not disclosed to other organisations except service agents or sometimes the applicable retailer.

Focus Lifestyle Products has a Privacy Policy (*available on request*), which encompasses compliance with the Privacy Act 1988 (Cth). Importantly, individual consumers generally have a right to access information held about them.

Manufactured by
Grand Hall Enterprises Ltd China
for
Focus Lifestyle Products Pty Ltd

ABN 93 160 136 977

223 - 225 Governor Road, Braeside,
Victoria, Australia 3195

P.O. Box 532 Mordialloc,
Victoria, Australia 3195

enquiry@focuslifestyle.com.au

Tel: (03) 8586 2200 or FreeCall: 1800 680 405

Fax: (03) 9587 7965

All specifications are subject to change
without notice.