

# Covered Cooker Barbecue

*Operating and assembly instructions*

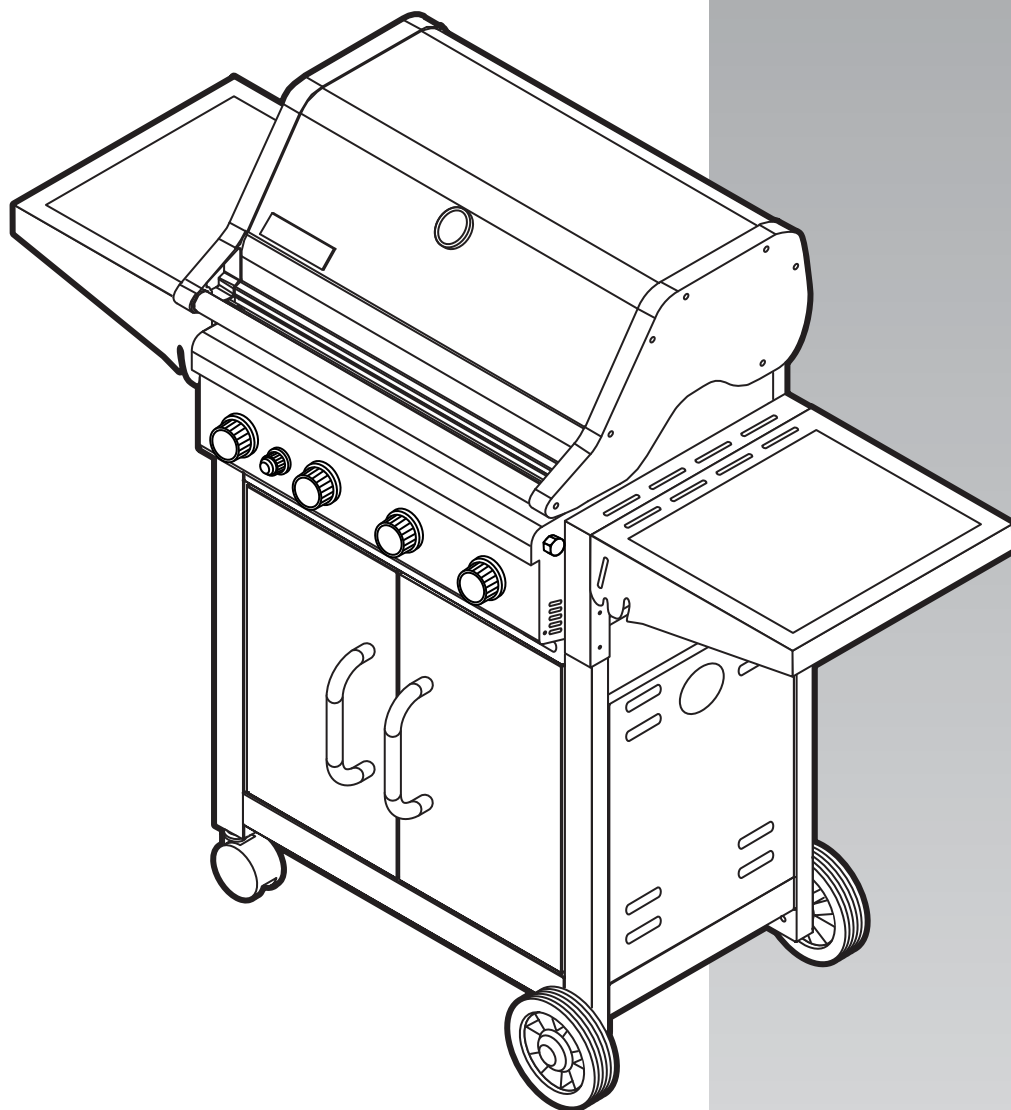

## **FOR YOUR SAFETY.**

### ***IF YOU SMELL GAS:***

1. Shut off gas to the appliance, if possible.
2. Extinguish any open flame.
3. Open hood.
4. If odour continues, immediately call your gas supplier or fire department.

## **FOR YOUR SAFETY.**

1. Do not store or use petrol or other flammable vapours and liquids in the vicinity of this or any other appliance.
2. A gas cylinder not connected for use must not be stored in the vicinity of this or any other appliance.

*These instructions are a guide to assembling and using the **Premium 322** barbecue.*

*Please read carefully, and retain for future reference.*

*Only to be used outdoors.  
Illustration may vary from barbecue contained in carton.*

## TABLE OF CONTENTS

General Information	2
Safety	3-4
Outdoor Areas	5
Pre-Assembly	6
Assembly – <i>General</i>	7-14
Operation	15-16
Fault Finding	17
Maintenance	18-20
Parts List	22-23

## FOR CUSTOMER REFERENCE

*(Record and file in a safe place)*

Purchased from \_\_\_\_\_

Date purchased \_\_\_\_\_

Serial No. \_\_\_\_\_

**NOTE: Sales docket must be kept as proof of purchase date.**

Barbecues for use with bottled gas are labelled 'Universal LPG' or 'Propane'. Barbecues for use with natural gas are labelled 'Natural Gas' and must be installed by an authorised person. Check the gas type sticker attached to the barbecue. Check that the label matches the gas type to be used.

Your barbecue is preset at the factory to operate on bottled gas only, unless specified otherwise.



- **FAILURE TO COMPLY WITH THESE INSTRUCTIONS COULD RESULT IN A FIRE OR EXPLOSION WHICH COULD CAUSE SERIOUS BODILY INJURY, DEATH OR PROPERTY DAMAGE**
- **ACCESSIBLE PARTS MAY BE VERY HOT**
- **KEEP YOUNG CHILDREN AWAY**
- **ANY MODIFICATION OF THIS APPLIANCE MAY BE DANGEROUS**
- **DO NOT MOVE THIS APPLIANCE DURING USE**
- **TURN OFF THE GAS SUPPLY AT THE GAS CYLINDER AFTER USE**
- **READ THE INSTRUCTIONS BEFORE USING THE APPLIANCE**
- **PARTS SEALED BY THE MANUFACTURER MUST NOT BE ALTERED IN ANY WAY**
- **THIS BARBECUE IS ONLY TO BE USED OUTDOORS.**

## GAS INSTALLATION CODES

This appliance is certified to AS 4557 by the Australian Gas Association. Refer data label on the barbecue for certificate number.

Barbecues must be used in accordance with the installation requirements of your local gas supply authority, and the appropriate installation standard AS5601.

## CLEARANCES

The following minimum clearances from combustible materials must be maintained when barbecue is in use:

top – 1000 mm, rear – 450 mm, sides – 250 mm.

Openings at the rear and sides of the appliance provide air for combustion and must not be obstructed.

## HOSE AND REGULATOR SAFETY



**NEVER OPERATE THIS BARBECUE WITHOUT A REGULATOR.**

The regulator and hose assembly supplied with the barbecue are suitable for use with bottled gas.

This regulator is adjusted to have an outlet pressure of 2.75 kPa for connection to a gas cylinder only. The regulator and hose assembly supplied with the appliance must be used. Replacement regulator and hose assemblies must be those specified by the appliance manufacturer.

When connecting the hose and regulator assembly to the gas cylinder, take care to avoid unnecessary twisting of the flexible hose. Also, take care to avoid a loose connection with the gas cylinder. After the assembly has been secured, turn on the gas and check for leaks by brushing a soap and water solution over all visible and accessible gas line connections. Include checking those connections which were made by your supplier. The presence of bubbles will indicate a gas escape. **DO NOT TEST FOR GAS ESCAPES WITH AN OPEN FLAME.** If you are unable to correct the leak by tightening the connections, turn off the gas and contact your place of purchase immediately.

Always ensure the appliance is kept away from flammable materials and the gas cylinder clear of any heat source. When changing over from an empty gas cylinder to a full one, make sure this procedure is carried out in a flame free atmosphere.

Inspect the gas hose assembly when exchanging the gas cylinder, or at least once a year, whichever is more frequent. If the 'O-Ring' or PVC hose is cracked, cut, abraded or damaged in any way, the appliance must not be operated. The complete assembly must be replaced if damaged and when statutory conditions require it. Contact your place of purchase if uncertain.

## OVERALL DIMENSIONS

Height

- hood closed 1185 mm, hood open 1405 mm

Width (*including trolley*)

- 4 burner 1385 mm

Depth

- hood closed 530 mm, hood open 630 mm

## SPECIFICATIONS

Appliance specifications can be found on the data label attached to the side panel of the barbecue body.



**READ CAREFULLY BEFORE ASSEMBLING AND OPERATING YOUR BARBECUE.**



**FOR YOUR SAFETY:**

- **DO NOT STORE OR USE PETROL OR OTHER FLAMMABLE VAPOURS AND LIQUIDS IN THE VICINITY OF THIS OR ANY OTHER APPLIANCE**
- **DO NOT STORE EMPTY OR FULL SPARE GAS CYLINDERS UNDER OR NEAR THIS OR ANY OTHER APPLIANCE**
- **KEEP THE GAS HOSE AWAY FROM HOT SURFACES. PROTECT GAS HOSE FROM DRIPPING GREASE. AVOID UNNECESSARY TWISTING OF HOSE. VISUALLY INSPECT HOSE PRIOR TO EACH USE FOR CUTS, CRACKS, EXCESSIVE WEAR OR OTHER DAMAGE. REPLACE HOSE, IF NECESSARY**
- **NEVER TEST FOR GAS LEAKS WITH A LIT MATCH OR OPEN FLAME**
- **NEVER LIGHT BARBECUE WITH LID ON OR HOOD CLOSED**
- **NEVER LEAN OVER COOKING SURFACE WHILE LIGHTING BARBECUE**
- **USE GOOD QUALITY INSULATED OVEN MITTS WHEN OPERATING BARBECUE**
- **NEVER ALTER OR MODIFY THE REGULATOR OR GAS SUPPLY ASSEMBLY**
- **THIS BARBECUE MUST NOT BE USED INDOORS.**

### LOCATION OF YOUR BARBECUE

*DO NOT use your barbecue in garages, porches, breezeways, sheds or other enclosed areas. Your barbecue is to be used **OUTDOORS ONLY**. Refer to page 5. The barbecue is not intended to be installed in or used on recreational vehicles and/or boats and should not be placed under any surface that will burn. Do not obstruct the flow of combustion and ventilation air around the barbecue housing while in use.*

### SERVICING



**ANY OF THE FOLLOWING SIGNS MAY INDICATE THAT THE APPLIANCE IS NOT OPERATING PROPERLY AND MAY NEED SERVICING:**

- **EXCESSIVE YELLOW FLAME**
- **IRREGULAR SIZE OF FLAME ACROSS BURNER**
- **'POPPING' OF FLAME**
- **SOOTING**
- **ABNORMAL NOISE(S)**
- **HISSING SOUND**

**NOTE:** Before requesting service, please refer to page 19 'Fault Finding'.

### PROTECT CHILDREN

Keep children away from barbecue during use and until barbecue has cooled after you are finished. Do not allow children to operate barbecue or to swing on hood handle.

### CHECKING FOR GAS LEAKS

**NEVER TEST FOR LEAKS WITH A FLAME.**

Prior to first use, and at the beginning of each new season (or, if using bottled gas, whenever gas cylinder is changed), you must check for gas leaks. Follow these steps:

1. Make soap solution by mixing one part liquid detergent and four parts water.
2. Turn burner control(s) to 'OFF', then turn on gas at source.
3. Apply the soap solution to all visible and accessible gas connections including the gas cylinder. Bubbles will appear in the soap solution if connections are not properly sealed. Tighten or rectify as necessary. Refer to page 4 for further details.
4. If you have a gas leak you cannot rectify, turn off the gas at the source. Contact the manufacturer for assistance. Refer to back cover.

### GAS CYLINDER USE & SAFETY

This is a low pressure barbecue and must only be used with the hose and regulator supplied.

Your barbecue is designed for use with a 9 kg gas cylinder. Ensure gas cylinder conforms to Australian Standard AS2469 and is less than 10 years old.

**DO NOT CONNECT YOUR BARBECUE TO A GAS CYLINDER LESS THAN OR EXCEEDING THIS CAPACITY.**



**NEVER CONNECT AN UNREGULATED GAS CYLINDER TO YOUR BARBECUE.**

The gas cylinder should be filled by a reputable gas dealer, or exchanged at a reputable gas cylinder exchange outlet. Gas cylinders should be visually inspected and re-qualified periodically.

Always keep gas cylinder in an upright position. Always close the cylinder valve when the barbecue is not in use.

Do not subject the gas cylinder to excessive heat.



- **NEVER STORE YOUR GAS CYLINDER INDOORS**
- **FOR STORAGE AND CYLINDER EXCHANGE, DISCONNECT HOSE AT THE CYLINDER ONLY. DO NOT DISCONNECT HOSE FROM THE APPLIANCE.**

If you store your barbecue indoors, ALWAYS disconnect and remove gas cylinder FIRST, and store gas cylinder safely outside. Gas cylinders must be stored outdoors in a well ventilated area out of reach of children, and must not be stored in a building, garage or any other enclosed area.



**DANGER – IF YOU SMELL OR HEAR THE HISS OF ESCAPING GAS FROM THE GAS CYLINDER:**

- **KEEP CLEAR OF THE GAS CYLINDER**
- **TURN ALL CONTROLS ON THE BARBECUE TO 'OFF'**
- **EXTINGUISH ANY OPEN FLAME**
- **REMOVE LID OR OPEN HOOD**
- **IF ODOUR CONTINUES, IMMEDIATELY CALL YOUR GAS SUPPLIER OR FIRE DEPARTMENT.**



**ALWAYS CHECK FOR GAS LEAKS  
EACH TIME YOU USE YOUR BARBECUE.**

You should follow this procedure after any of the following:

- Not having used the barbecue for an extended period of time,
- Initial assembly of barbecue,
- Any disconnection and reconnection of hose assembly,
- Changing gas cylinder,
- Upon re-connecting gas cylinder after it has been disconnected for storage.

#### CHECKING FOR GAS LEAKS



**NEVER CHECK FOR LEAKS WITH  
A FLAME.**

1. Make liquid detergent solution by mixing one (1) part liquid detergent and four (4) parts water.

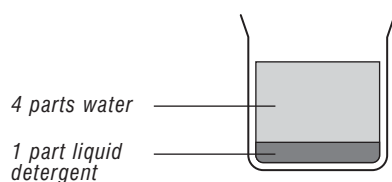

2. Turn burner control knob(s) to 'OFF', then turn on gas at source.

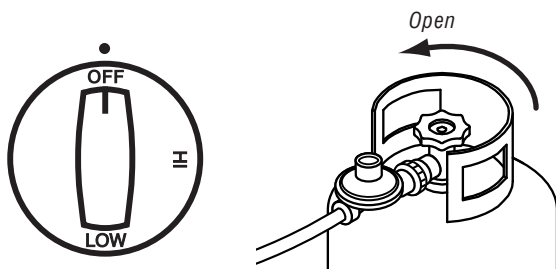

3. Although the gas hoses are factory fitted and checked for leaks, it is advisable to recheck in case the connections have been disturbed during shipment or assembly.

Apply the liquid detergent solution to all visible and accessible gas connections, including the connection to the gas cylinder. Bubbles will appear in the liquid detergent solution if connections are not properly sealed. Tighten or rectify as necessary.

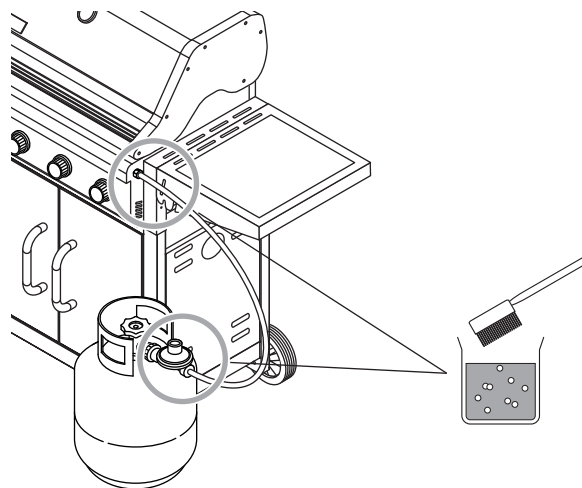

**IF YOU HAVE A GAS LEAK YOU  
CANNOT RECTIFY, TURN OFF THE GAS  
AT THE SOURCE. CONTACT THE  
MANUFACTURER.**



**THIS APPLIANCE SHALL ONLY BE USED IN AN ABOVE GROUND OPEN AIR SITUATION WITH NATURAL VENTILATION, WITHOUT STAGNANT AREAS, WHERE GAS LEAKAGE AND PRODUCTS OF COMBUSTION ARE RAPIDLY DISPERSED BY WIND AND NATURAL CONVECTION.**

**ANY ENCLOSURE IN WHICH THE APPLIANCE IS USED SHALL COMPLY WITH ONE OF THE FOLLOWING:**

- AN ENCLOSURE WITH WALLS ON ALL SIDES, BUT AT LEAST ONE PERMANENT OPENING AT GROUND LEVEL AND NO OVERHEAD COVER
  - WITHIN A PARTIAL ENCLOSURE THAT INCLUDES AN OVERHEAD COVER AND NO MORE THAN TWO WALLS
  - WITHIN A PARTIAL ENCLOSURE THAT INCLUDES AN OVERHEAD COVER AND MORE THAN TWO WALLS, THE FOLLOWING SHALL APPLY:
    - (i) AT LEAST 25% OF THE TOTAL WALL AREA IS COMPLETELY OPEN: AND
    - (ii) AT LEAST 30% OF THE REMAINING WALL AREA IS OPEN AND UNRESTRICTED
  - IN THE CASE OF BALCONIES, AT LEAST 20% OF THE TOTAL OF THE SIDE, BACK AND FRONT WALL AREAS SHALL BE AND REMAIN OPEN AND UNRESTRICTED
  - DO NOT USE YOUR BARBECUE IN GARAGES, PORCHES, BREEZEWAYS, SHEDS OR OTHER ENCLOSED AREAS.
- YOUR BARBECUE IS TO BE USED OUTDOORS ONLY. Refer below**
- THE BARBECUE IS NOT INTENDED TO BE INSTALLED IN OR USED ON RECREATIONAL VEHICLES AND/OR BOATS AND SHOULD NOT BE PLACED ADJACENT TO OR UNDER ANY SURFACE THAT WILL BURN
  - DO NOT OBSTRUCT THE FLOW OF COMBUSTION AND VENTILATION AIR AROUND THE BARBECUE HOUSING WHILST IN USE.

The following diagrams are examples of outdoor areas. These same principles apply to canopy or shaded cloth areas.

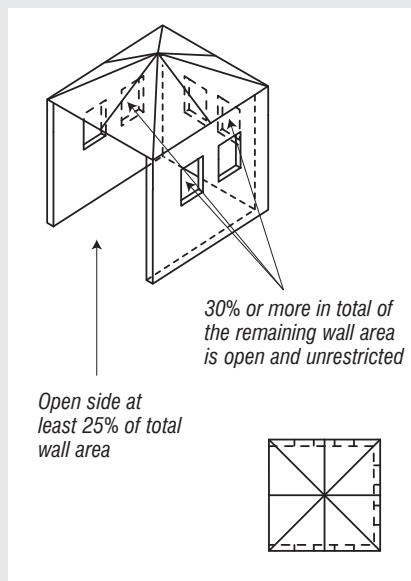
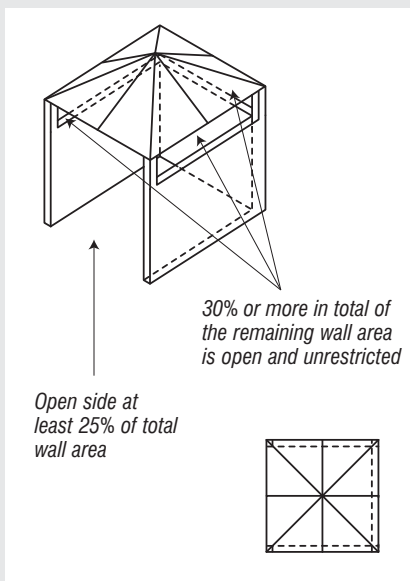
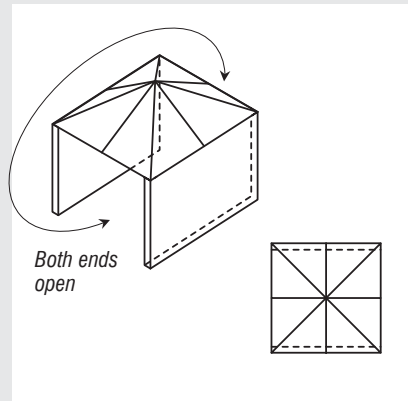
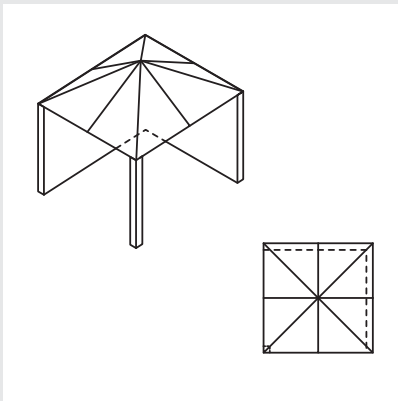
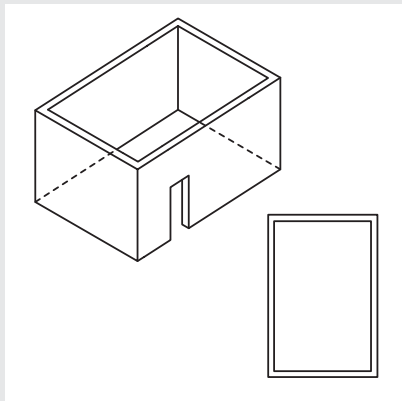

**GENERAL**

While it is possible for one person to assemble the barbecue, we recommend asking for the assistance of another person when manoeuvring some of the larger or heavier pieces.

**ASSEMBLY TIPS**

1. Flatten cardboard packaging and use this as a protective work surface to assemble upon.
2. Some protective coating may need to be removed from components prior to assembly.
3. Do not tighten screws and nuts until trolley is fully assembled, unless specified.
4. Pre-screwing of connection points for securing the side shelves will assist in securing shelves smoothly.

**CHECK BARBECUE FOR ANY DAMAGE**

Before attempting to assemble your barbecue, check that all the necessary parts have been included using the parts list opposite. Inspect barbecue and trolley parts as you proceed.

Contact your place of purchase for assistance regarding replacement of any damaged or missing parts. Supplier contact details are on the back cover of the instruction manual.

Do not assemble or operate a barbecue that appears damaged.

Check that the barbecue supplied is correct for the gas type being used. There is a label on the side panel of the barbecue above the gas connection. Barbecues for use with gas cylinders are labelled '*Universal LPG*' or '*Propane*'. Barbecues for use with natural gas are labelled '*Natural Gas*'.

**TOOLS YOU WILL NEED**

Standard Phillips-head screwdriver.  
Adjustable spanner (*open end shifter*).

**CARTON CONTENTS****BARBECUE COMPONENTS:**

- 1 Barbecue body.
- 1 Grease draining tray.
- 1 Grease receptacle.
- 2 Flame tamer.
- 1 Hot plate & 1 slotted grill plate.
- 2 Trolley legs – *LH castor*.
- 2 Trolley legs – *RH wheel*.
- 1 Trolley base tray.
- 2 Castor wheels.
- 1 Gas cylinder hook.
- 2 6" wheels with hubcaps.
- 1 Trolley rear panel.
- 1 Trolley side panel – *RH*.
- 1 Trolley side panel – *LH*.
- 1 Gas cylinder housing.
- 1 Gas cylinder bracket.
- 1 Gas cylinder strap.
- 1 Trolley door bracket.
- 2 Doors.
- 2 Door handles.
- 2 Door stop plate.
- 2 Side shelf – *LH / RH foldable*.
- 1 Hardware pack.

### 1 INSTALL TROLLEY LEGS

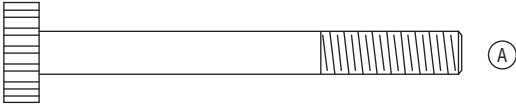

Pattern-head screw, part threaded  $\frac{1}{4}$ " x  $2\frac{3}{4}$ "  
Qty: 4

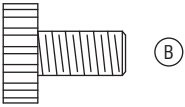

Pattern-head screw  $\frac{1}{4}$ " x  $\frac{1}{2}$ "  
Qty: 4

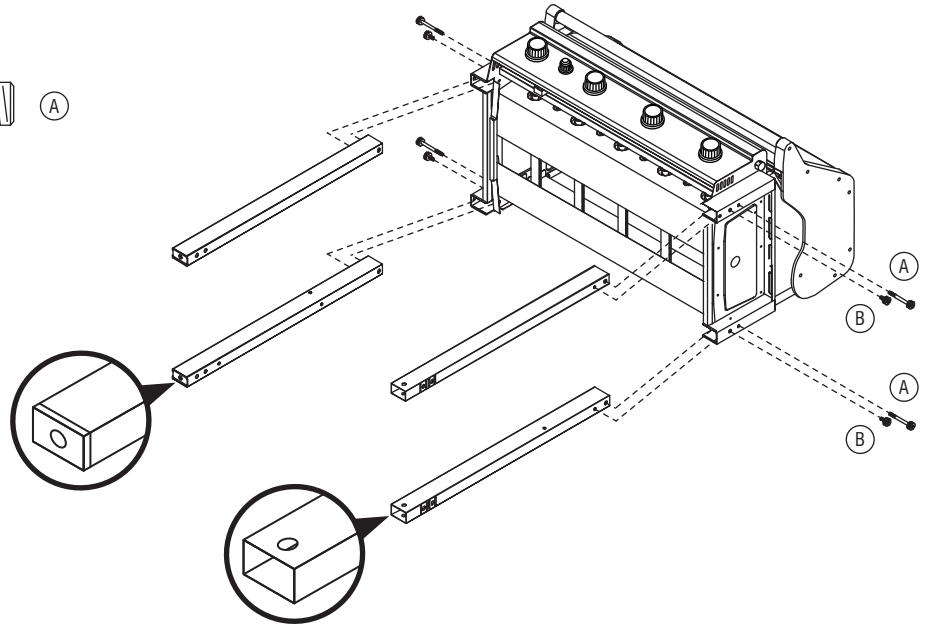

### 2 INSTALL TROLLEY BASE TRAY

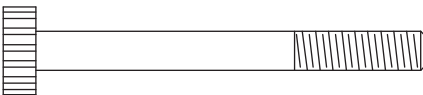

Pattern-head screw, part threaded  $\frac{1}{4}$ " x  $2\frac{3}{4}$ "  
Qty: 8

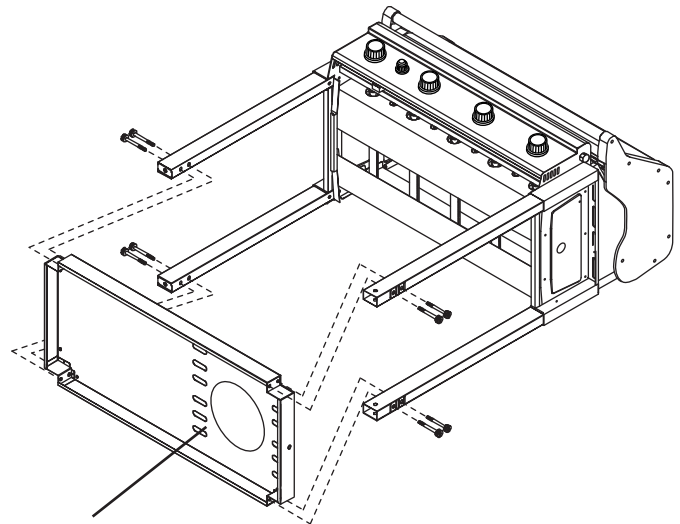

*Note: Gas cylinder housing hole to right side*

### 3 INSTALL WHEELS

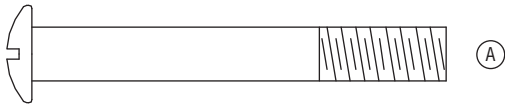

Wheel bolt  $\frac{3}{8}$ " x  $3\frac{3}{8}$ "  
Qty: 2

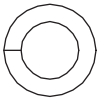

(B) Spring washer  $\frac{3}{8}$ "  
Qty: 2



(C) Lock nut  $\frac{3}{8}$ "  
Qty: 2

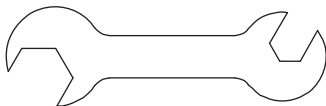

Customised spanner

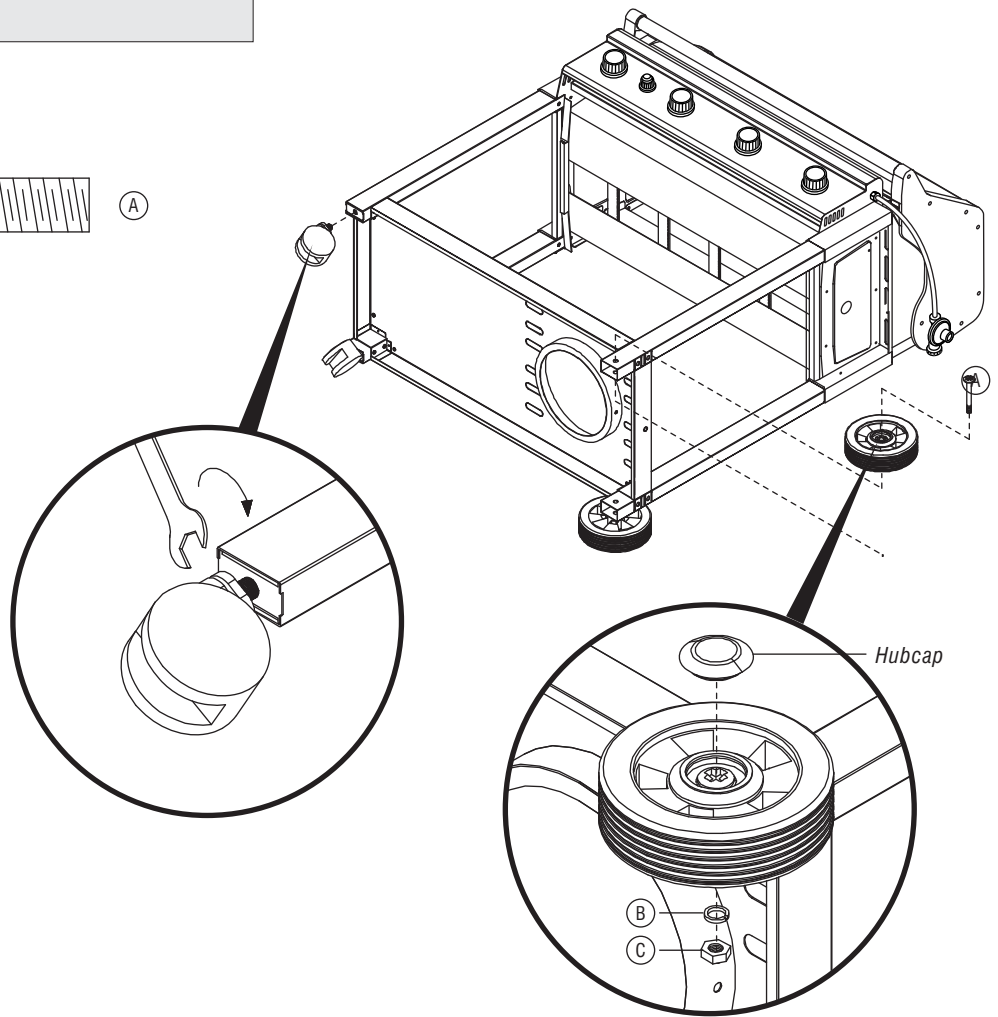

### 4 INSTALL TROLLEY REAR PANEL

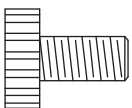

Pattern-head screw  $\frac{1}{4}$ " x  $\frac{1}{2}$ "  
Qty: 4

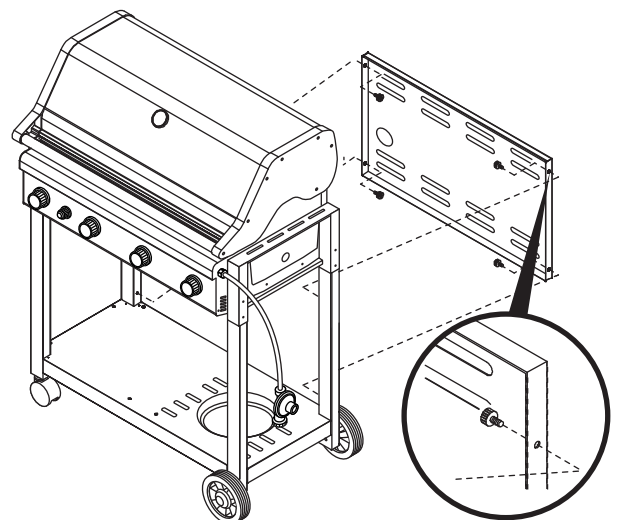

**5 INSTALL GAS CYLINDER BRACKET AND TROLLEY SIDE PANELS**

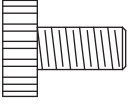

Pattern-head screw  $1/4" \times 1/2"$   
Qty: 8

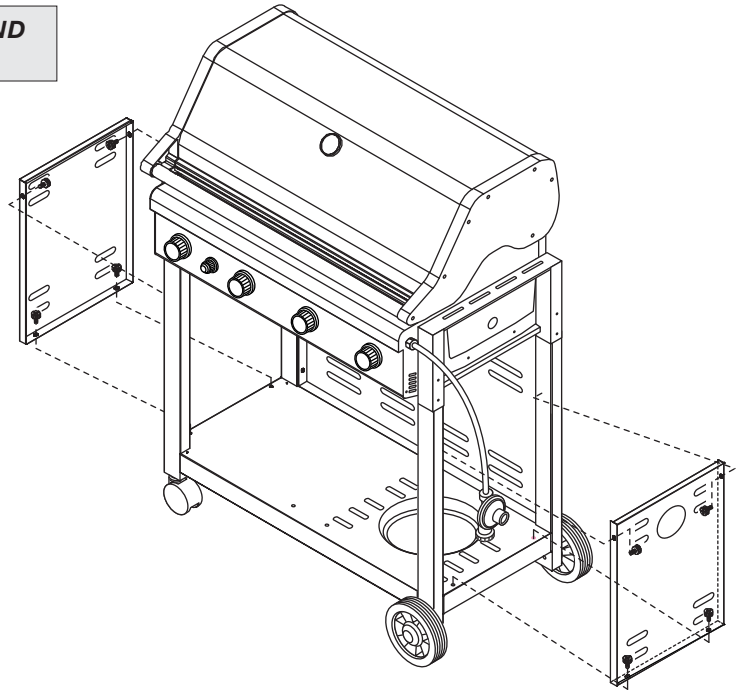

**6 INSTALL DOOR BRACKET, DOOR STOP AND DOOR MAGNET**

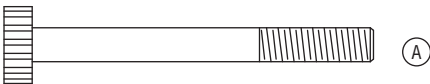

Pattern-head screw, part threaded  $1/4" \times 23/4"$   
Qty: 2



Pattern-head screw  $1/4" \times 1/2"$   
Qty: 6



Magnetic door stop  
Qty: 2

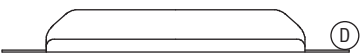

Door stop plate  
Qty: 1 Scale: 1:2

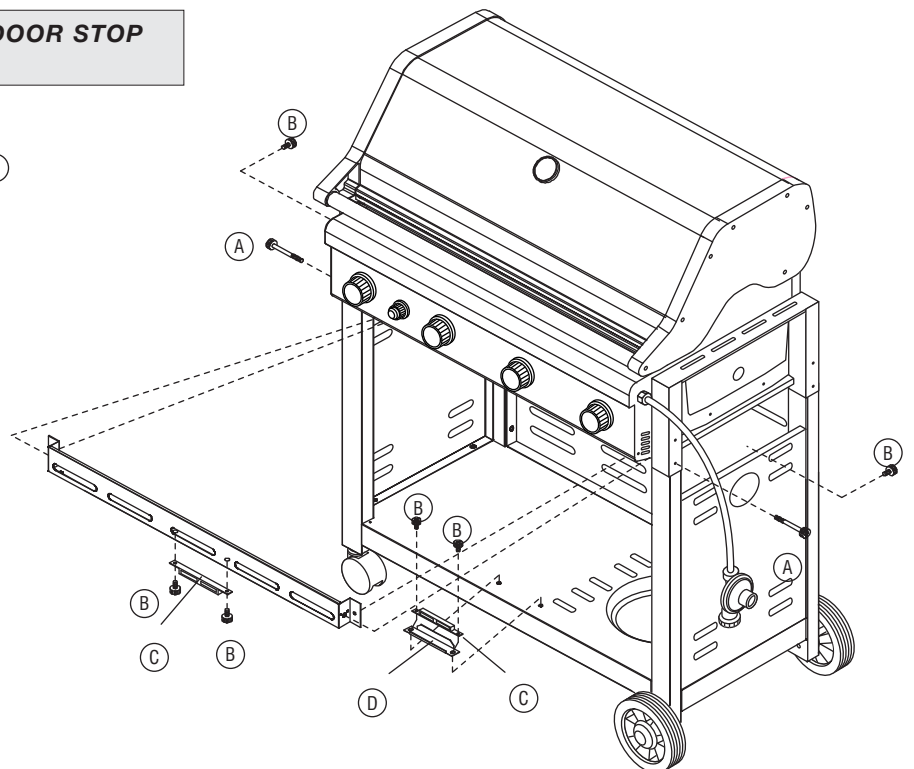

**NOTE: THE 'DOOR STOP PLATE' MOUNTS UNDERNEATH THE 'MAGNETIC DOOR STOP'.**

**7 INSTALL DOOR HANDLES**

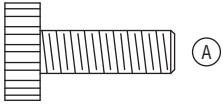

1/4" x 3/4" Pattern-head screw  
Qty: 4

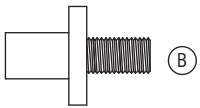

1/4" x 3/8" Door hinge pin  
Qty: 2

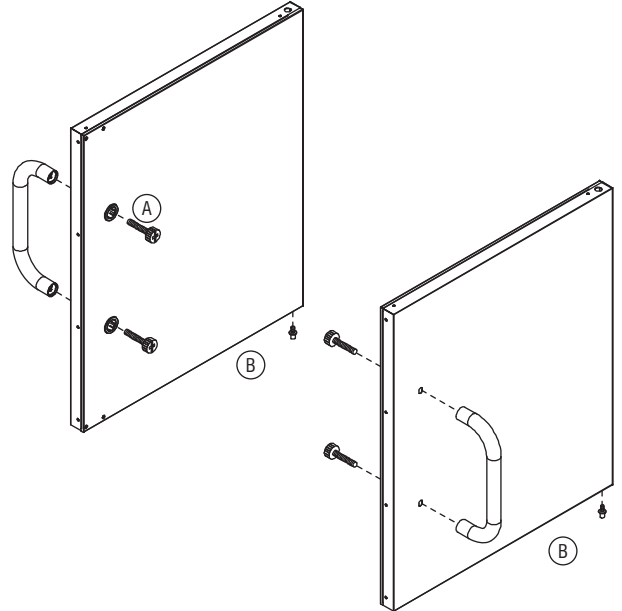

**8 INSTALL DOOR TO TROLLEY BRACKET**

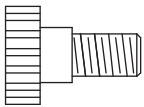

1/4" x 5/8" Pattern-head screw – part threaded  
Qty: 2

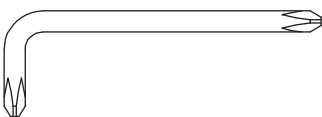

L-screwdriver

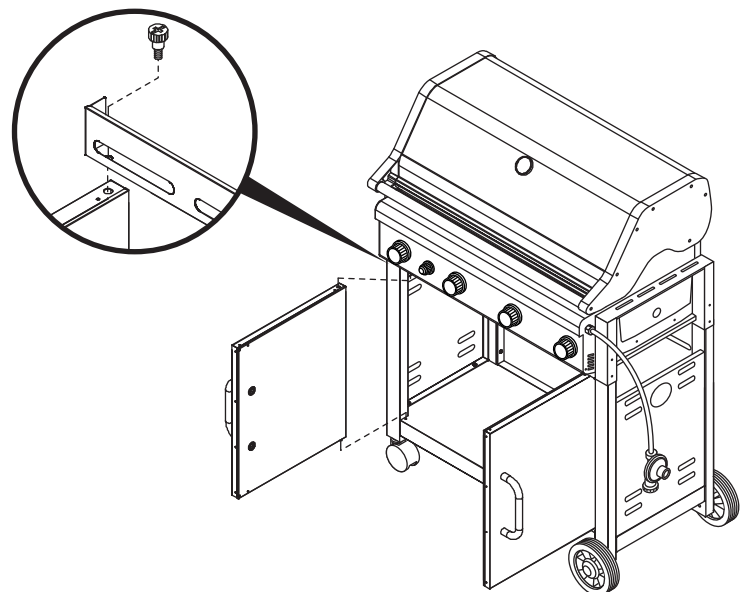

### 9 INSTALL GREASE DRAINING TRAY AND GREASE RECEPTACLE

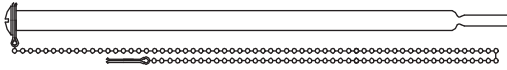

Lighting stick  
Qty: 1

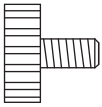

M4 x 8 mm Pattern-head screw  
Qty: 1

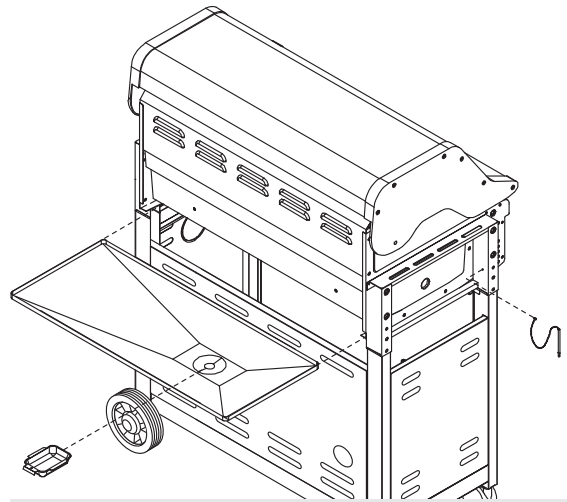

- **CONTENTS OF GREASE DRAINING TRAY AND GREASE RECEPTACLE MAY BE VERY HOT DURING COOKING**
- **ALLOW TO COOL COMPLETELY BEFORE DISPOSING OF THE CONTENTS**
- **AFTER CONTINUOUS USE, FAT AND/OR COOKING JUICES MAY BUILD UP. TO AVOID ANY FLARE-UPS, IT IS RECOMMENDED THAT THE GREASE TRAY AND RECEPTACLE BE EMPTIED REGULARLY.**

### 10 INSTALL SIDE SHELF / SIDE BURNER

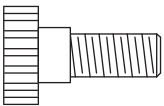

1/4" x 1/2" Phillips-head screw, part thread  
Qty: 8

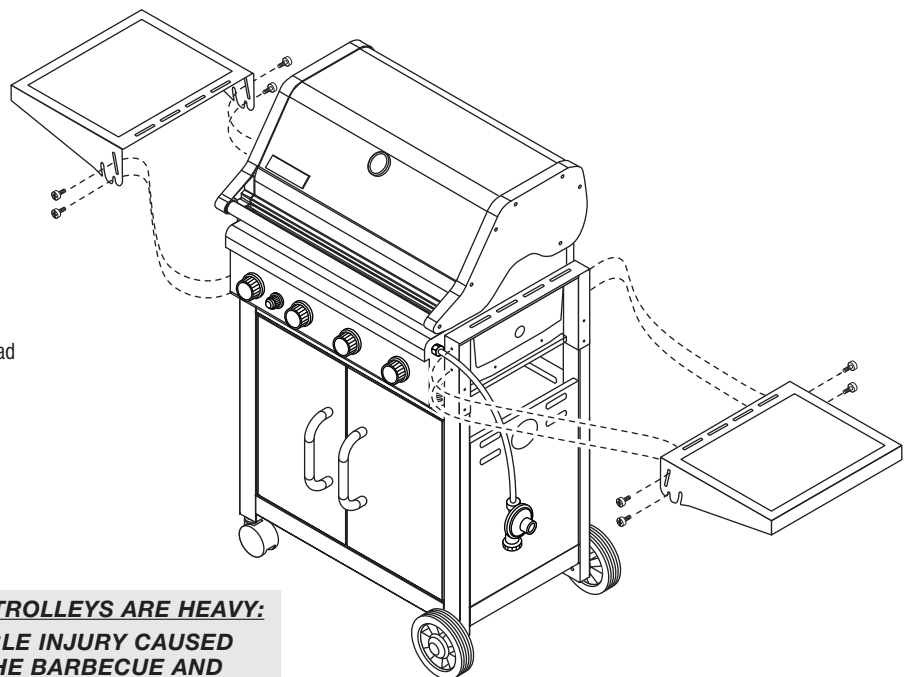

**BARBECUES ON TROLLEYS ARE HEAVY: TO AVOID POSSIBLE INJURY CAUSED WHEN MOVING THE BARBECUE AND TROLLEY, THE BARBECUE SHOULD BE PUSHED FORWARD, AND NOT PULLED FROM BEHIND.**

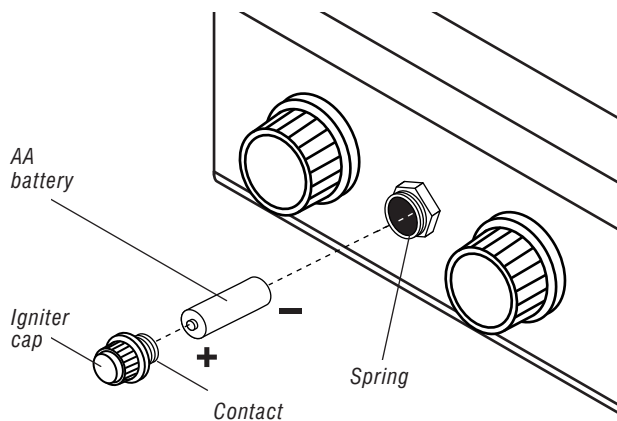
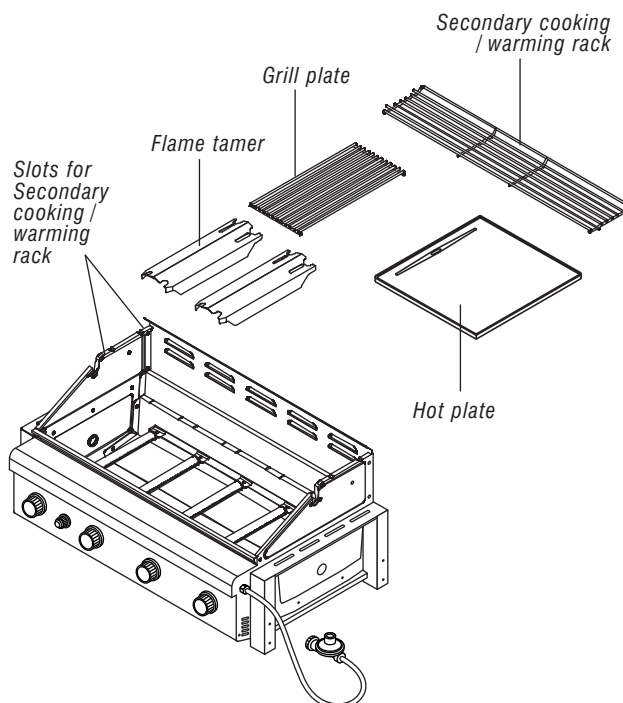
**IGNITION BATTERY****COOKING COMPONENT INSTALLATION****FLAME TAMERS**

- The flame tamer is designed to reduce flaring. The plates fit onto the ledge at the front and rear of the barbecue body. Depending on the model you have purchased, position as indicated above.
- Do not install flame tamer directly under the hot plate. For this barbecue model, the central flame tamer will position partially under the hot plate.



**DO NOT COVER ENTIRE COOKING SURFACE WITH SOLID PLATES, AS THIS WILL RESULT IN POOR COOKING PERFORMANCE, OR THE BURNERS MAY GO OUT, CREATING A HAZARDOUS SITUATION.**



**IMPORTANT: BEFORE USING THIS BARBECUE ENSURE THAT ALL PROTECTIVE FILM HAS BEEN REMOVED THEN CLEAN ALL SURFACES WITH A HOT DETERGENT SOLUTION TO REMOVE TRACES OF ADHESIVE OR MACHINE OILS. STAINLESS STEEL SURFACES MAY BE CLEANED WITH A 'COMMERCIAL STAINLESS STEEL CLEANER'.**



**NOTE: ALL GAS CONNECTIONS ARE FACTORY SUPPLIED. ENSURE CONNECTIONS HAVE NOT BEEN DISTURBED DURING SHIPMENT OR ASSEMBLY BY PERFORMING THE LEAK TEST DESCRIBED ON PAGE 3.**

### NATURAL GAS INSTALLATION

This barbecue is also certified for use on natural gas. Contact the manufacturer for advice in relation to using your barbecue on natural gas. *Refer back cover.*

Barbecues for use on natural gas must be installed by an authorised person.

### ENSURING BURNER CONTROLS ARE OFF

**IMPORTANT:** Before connecting and disconnecting barbecue to gas source, ensure burner controls are in 'OFF' position.

**NOTE:** The 'OFF' position on the control panel is identified by either a small black dot / a short vertical black line / or the word 'OFF'.

When the marking, or the word 'OFF' printed on the control knob, aligns with the printed marking on the control panel, then the burner is in the fully off position.

**CAUTION:** When the appliance is not in use, the gas must be turned off at the gas cylinder.

Familiarise yourself with the general information and safety guidelines located at the front of this booklet. Check to see that gas cylinder is filled and that end of each burner tube is properly located over each valve orifice. Set burner controls to 'OFF' position.

### CONNECTING TO, AND DISCONNECTING FROM GAS SOURCE



**TEST FOR LEAKS WITH A SOAP SOLUTION, NEVER WITH AN OPEN FLAME (Refer pages 3 and 4).**

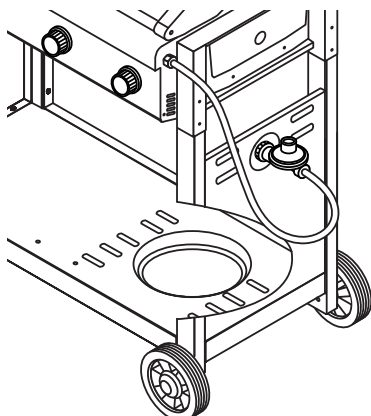

### CONNECTING TO GAS SOURCE

1. Place gas cylinder into cylinder housing, facing the gas valve to front right corner.
2. Attach cylinder connection device of regulator and hose assembly to cylinder valve outlet. **Tighten firmly.**
3. Open the gas cylinder valve fully to allow gas to flow.
4. Leak test all accessible connections thoroughly using a soapy water solution prior to lighting the barbecue. *Refer to Safety information, pages 3 and 4.*
5. If a leak is found, turn gas cylinder valve off and do not use barbecue until repairs or replacement can be made.

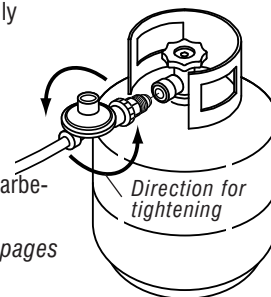

### DISCONNECTING FROM GAS SOURCE

1. Turn the burner control 'OFF'.
2. Turn the gas cylinder valve off fully.
3. Detach the regulator assembly from gas cylinder valve.



- **DISCONNECT AND REMOVE GAS CYLINDER WHEN MANOEUVRING THE BARBECUE OVER UNEVEN SURFACES OR CARRYING UP AND DOWN STAIRS**
- **IF THIS INFORMATION IS NOT FOLLOWED EXACTLY, A FIRE CAUSING DEATH OR SERIOUS INJURY MAY OCCUR!**
- **DO NOT STORE A SPARE GAS CYLINDER UNDER OR NEAR THIS APPLIANCE**
- **THIS BARBECUE IS ONLY TO BE USED OUTDOORS.**

**WITH THE ASSISTANCE OF ANOTHER PERSON, PERFORM THIS ELECTRODE CHECK BEFORE PROCEEDING.**

This test will ensure that the spark electrode tips are properly positioned so your barbecue lights easily and properly.

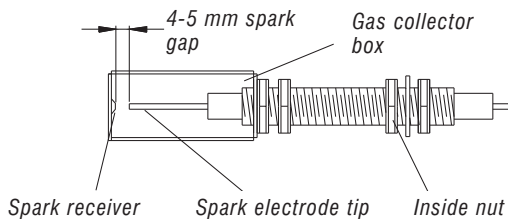

Ensure the gas source is turned off – or is disconnected and all burner control knobs are set to 'OFF' – and open the lids / side shelves.

Have your assistant stand behind to the right of the barbecue and look toward the front of the barbecue. Never put your face inside the barbecue.

Press the push button ignition. You should hear a 'clicking' sound. Your assistant should see a blue spark within each gas collector box. If a spark is present the electrode tips are properly positioned.

**If no spark is seen, the spark gap needs to be adjusted as follows:**

- Using an adjustable spanner, loosen the inside nut until the gas collector box can be turned upward. If the gap between the spark electrode tip and receiver is more than 4 - 5 mm use long nose pliers to gently squeeze the gas collector box to narrow gap. Return the gas collector box to its original position, secure the inside nut and try the electrode check again.



- **CHECK PERFORMANCE OF BURNERS PRIOR TO INSTALLING BARBECUE PLATE COMPONENTRY. Refer page 16 for lighting instructions**
- **DO NOT SMOKE WHEN ATTEMPTING TO IGNITE BARBECUE**
- **NEVER USE VOLCANIC ROCK, HEAT BEADS OR OTHER MATERIAL TO COVER THE BURNERS. USE ONLY COMPONENTS SUPPLIED IN THE CARTON**
- **ALWAYS USE PROTECTIVE GLOVES WHEN HANDLING HOT COMPONENTS.**

**TEMPERATURE GAUGE**

The temperature gauge is used as a guide to cooking temperatures when cooking with the hood closed. When an opening is provided in the hood, this allows for the installation of the temperature gauge. *Install as shown in the diagram, if not factory fitted.*

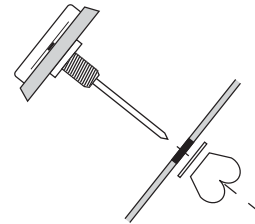

**NOW YOUR BARBECUE IS READY TO USE**

Before first use and at the beginning of each barbecue season:

1. Please read *Safety, Lighting and Operating instructions* carefully.
2. Check gas valve orifices, burner tubes and burner ports for any obstructions. *eg. spiders, webs, insects.*
3. Check and ensure the gas cylinder is full.
4. **Ensure all connections are securely tightened. Check for gas leaks. See pages 3 and 4.**

### LIGHTING PROCEDURES



- **THE HOOD MUST BE IN THE OPEN POSITION FOR LIGHTING**
- **DO NOT SMOKE AT ALL TIMES WHEN ATTEMPTING TO IGNITE BARBECUE**
- **CAUTION: DO NOT MOVE TROLLEY WHILE BARBECUE IS IN OPERATION.**



**CAUTION: DO NOT LEAVE THE BARBECUE UNATTENDED WHEN BURNER/S IS ALIGHT.**

1. Always remove lid or open hood before lighting.
2. Set burner controls to 'OFF' and open the gas supply cylinder valve. Wait 30 seconds before attempting to light.

**NOTE: Upon first assembly the gas lines and burners will be full of air. In order for the burners to light properly the lines must fill with gas. It may require several attempts at lighting the burners before you are successful.**

3. Turn burner control 1 or 2 or side burner to the 'HI' position. Press the piezo ignition button until the flame appears on the burner. Cross light to other main burners in sequence from the lit burner.

(Plates, flame tamers removed to illustrate lighting procedure).

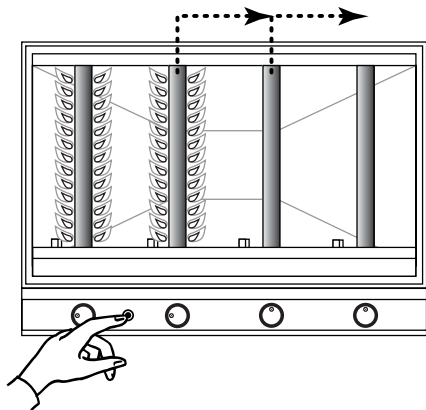

**NOTE: If any burners fail to light after several attempts, turn off gas supply at source.**

Wait until burners cool and inspect for obstructions to gas flow. See also Safety instructions (page 3).

### OPERATING PROCEDURE

#### Burn-off:

Before cooking on your barbecue for the first time, burn-off any residual oils or foreign matter from the cooking plates. **ENSURE THE LID IS REMOVED OR THE HOOD OPEN**, and operate at 'HI' setting for approximately 15 minutes. Allow to cool then wash grill / plate / pan thoroughly with soap suds and scrubbing brush. Rinse thoroughly and wipe clean with a cloth. Your grill / plate / pan is ready to use.

#### Preheating:

It is necessary to preheat the barbecue before cooking. Operate the burner at 'HI' for approximately 10 minutes before cooking. Hooded barbecues should be pre-heated with the hood down.

After the pre-heat period, open the hood and turn off or adjust burners as required.

### COOKING TEMPERATURES

'HI' setting – Use this setting only for warm up, for searing steaks and chops, and for burning food residue from the grill plates after the cooking is over. Rarely, if ever, do you use the 'HI' setting for extended cooking.

'MEDIUM' setting (mid-way between 'HI' and 'LOW'). Use this setting for most grilling, and for cooking hamburgers and vegetables.

'LOW' setting – Use this setting when cooking very lean cuts such as fish.

Actual cooking surface temperatures vary with outside temperature and the wind conditions.

### MANUAL LIGHTING

If for some reason, igniters fail to produce a spark at the electrode, barbecue can be lit carefully with a match.

Insert lit match or long-necked butane lighter through lighting hole located on left side of barbecue body, after turning the left burner control to the 'HI' position.

Sequentially light the remaining burners from left to right.

### LIGHT BARBECUE WITH MATCH

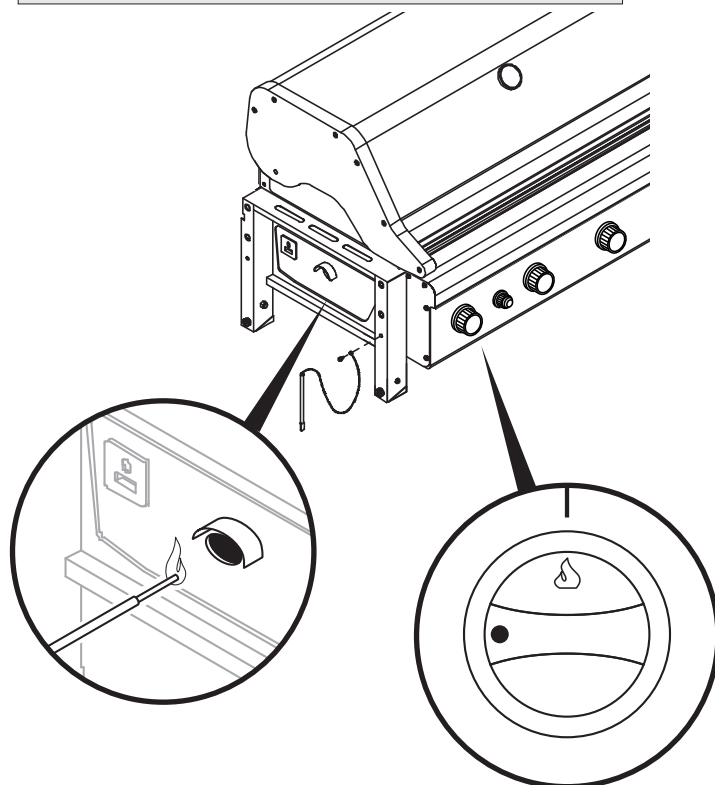

### FLARE-UPS

The fats and juices that drip from the meat may cause flare-ups. Since flare-ups impart the distinctive taste and colour for food cooked over an open flame, they should be expected and encouraged within reason. Nevertheless, uncontrolled flaring can result in a ruined meal.

### COOKING WITH THE HOOD DOWN

Cooking with the hood in the closed position helps to cook food more quickly than in conventional barbecues with a simple lid. The hood (when closed) helps to retain the heat more evenly and conserves energy.

**IMPORTANT:** Never use any burner or combination of burners on 'HI' for extended periods when cooking with the hood down.

High direct heat when the hood is down may result in burnt food, or damage to painted surfaces.

When roasting in your barbecue, food should be positioned over the centre burners either on a roasting rack with the cooking pan underneath, or directly in the cooking pan, or placed in a disposable aluminium foil dish on top of a flame tamer. Remove other grill plate and hot plate not being used, and ignite burners 1, 2 & 4.

The heat from the selected burners circulates gently throughout the barbecue, cooking the meat or poultry without any direct flame touching it. This method greatly reduces flare-ups when cooking extra fatty cuts, because there is no direct flame to ignite the fats and juices that drip during cooking.

### PRE-HEATING

With the hood open, ignite the burners as indicated. Once ignition is established, close the hood. Leave the burners on 'HI' for 10 minutes or until the temperature reaches a suitable level for cooking. Modulate the required temperature by turning the left and right burners progressively to 'LOW'.

### COOKING WITH HOOD DOWN

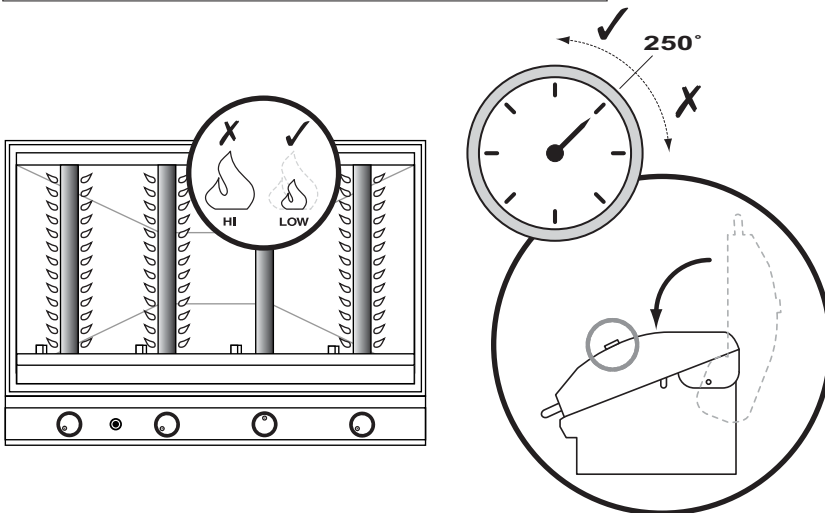



- **SHOULD A FLASHBACK FIRE OCCUR IN OR AROUND THE BURNER TUBES, FOLLOW THE INSTRUCTIONS BELOW. FAILURE TO COMPLY WITH THESE INSTRUCTIONS COULD RESULT IN A FIRE OR EXPLOSION THAT COULD CAUSE SERIOUS BODILY INJURY, DEATH, OR PROPERTY DAMAGE**
- **SHUT OFF GAS SUPPLY TO THE GAS BARBECUE.**
- **TURN THE CONTROL KNOBS TO OFF POSITION**
- **OPEN THE BARBECUE LID. PUT OUT ANY FLAME WITH A FIRE EXTINGUISHER**
- **ONCE THE BARBECUE HAS COOLED DOWN, CLEAN THE BURNER TUBES AND BURNERS ACCORDING TO THE CLEANING INSTRUCTIONS IN THIS OPERATOR'S MANUAL.**

**CAUTION:** If burners go out during operation, close gas supply at source, and turn all gas valves off. Open hood and wait 5 minutes before re-attempting to light (this allows accumulated gas fumes to clear).

**CAUTION:** Should grease fire occur, close gas supply at source, turn off all burners and remove food until fire is out.

**KEEP THE VENTILATION OPENINGS OF THE CYLINDER ENCLOSURE FREE AND CLEAR FROM DEBRIS.**

#### **IF THE BARBECUE FAILS TO LIGHT**

1. Turn gas off at source and turn burner control knobs to 'OFF'. Wait at least five (5) minutes for gas to clear, then retry.
2. If your barbecue still fails to light, check gas supply and connections.
3. Repeat lighting procedure. If your barbecue still fails to operate, turn the gas off at source, turn the control knobs to 'OFF', then check the following:
  - **Misalignment of burner tubes over orifices**  
*Correction:* Reposition burner tubes over orifices.
  - **Obstruction in gas line**  
*Correction:* Remove fuel line from barbecue. Do not smoke! Open gas supply for one second to clear any obstruction from fuel line. Close off gas supply at source and reconnect fuel line to barbecue.
  - **Plugged orifice**  
*Correction:* Remove burners from barbecue by removing the screw attaching the burner to the support rail. Carefully lift each burner up and away from gas valve orifice. Remove the orifice from gas valve and gently clear any obstruction with a fine wire. Then reinstall all orifices, burners, cotter pins and cooking components.  
  
If an obstruction is suspected in gas valves or manifold, contact your place of purchase or manufacture.
  - **Obstruction in burner tubes**  
*Correction:* Follow the burner tube cleaning procedure on page 20 of this operator's manual.
  - **Misalignment of igniter on burner**  
*Correction:* Check for proper position of the electrode tip as shown on page 14. The gap between the spark electrode tip and spark receiver should be approximately 4 - 5 mm. Adjust if necessary. With the gas supply closed and all control knobs set to 'OFF' press the electronic igniter cap and check for the presence of a spark at the electrode.
  - **Disconnected electronic wires**  
*Correction:* Inspect the igniter junction box found behind the control panel. Connect loose electronic wires to junction box and try to light the barbecue.
  - **Weak AA battery**  
*Correction:* Unscrew the igniter cap and replace the battery. Refer page 123.



**DO NOT USE OVEN CLEANER TO CLEAN THE BARBECUE.**

**SOME PROPRIETARY BARBECUE CLEANERS MAY AFFECT / DAMAGE SOME OF THE SURFACE COATINGS USED ON THE APPLIANCE. READ THE CLEANER INSTRUCTIONS CAREFULLY.**

**IT IS RECOMMENDED TO TEST IN AN INCONSPICUOUS PLACE FIRST. GENERALLY WE RECOMMEND ONLY WARM SOAPY WATER FOR CLEANING THE APPLIANCE.**



**FAILURE TO READ AND FOLLOW THE 'USE AND CARE INSTRUCTIONS' COULD RESULT IN A FIRE OR EXPLOSION THAT COULD CAUSE SERIOUS BODILY INJURY, DEATH OR PROPERTY DAMAGE.**



**IN COASTAL AREAS, FREQUENT CLEANING AND THE USE OF A COVER IS RECOMMENDED TO PROLONG THE LIFE OF THE APPLIANCE. SALTY AIR WILL ADVERSELY AFFECT EXPOSED PARTS.**

### CLEANING AND MAINTENANCE

Proper care and maintenance will keep your barbecue in top operating condition and prolong its life. Follow these cleaning procedures on a timely basis and your barbecue will stay clean and operate with minimum effort.

**CAUTION: Be sure your barbecue is off and cool before cleaning.**

### CLEANING THE COOKING PLATES

Before initial use, and periodically, wash your cooking plates in a mild soap and warm water solution. You can use a wash cloth or vegetable brush to clean your cooking plates.

It is recommended the cooking plates be coated with a thin layer of cooking oil on a regular basis to prevent rusting. Slight rusting can be removed with a scrubbing brush before use.

### CLEANING THE FLAME TAMERS

Periodically you should wash the flame tamer in a soap and warm water solution. Use a vegetable brush to remove stubborn burnt-on cooking residue. Dry the flame tamers thoroughly before you re-install them into the barbecue.

### CLEANING THE GREASE TRAY AND RECEPTACLE

To reduce the chance of fire, the grease draining tray and grease receptacle should be visually inspected before each barbecue use. Remove any grease and wash grease tray and receptacle with a mild soap and warm water solution.

### CLEANING EXTERIOR SURFACES

Before initial use, and periodically thereafter, we suggest you wash your barbecue using a mild soap and warm water solution. You can use a wash cloth or sponge for this process. Do not use a stiff wire or brass brush. These will scratch stainless steel and chip painted surfaces (*varies by model*) during the cleaning process.

### CARE FOR STAINLESS STEEL SURFACE

The stainless steel over time will be affected by 'tea staining' (*the brown discolouration of some stainless steel*).

Tea staining can be reduced by washing the surface with mild detergent and warm water. This should then be followed by rinsing with clean cold water. We recommend the surface then be wiped dry with a clean cloth.

## STORAGE

We recommend that you minimise the barbecue's exposure to the elements. High moisture content in the air (*rain, mist, salt spray etc.*) can affect metal components and lead to material breakdown. If left in an area subjected to high moisture content, we strongly recommend that you observe the cleaning procedure on a regular basis and cover the appliance whilst not in use (*covers are available as an optional extra*). Material breakdown from high moisture conditions can be avoided if the appliance is well protected from the weather and regular cleaning is carried out.

## ANNUAL CLEANING OF THE BARBECUE INTERIOR

Burning-off excess food after every cookout will keep it ready for instant use. However, at least every 3 months you must give the entire barbecue a thorough cleaning to minimise your risk of grease fire and keep the barbecue in top shape. *Follow these steps:*

1. Turn all burner valves to the full 'OFF' position.
2. Turn the LP gas cylinder valve to the full 'OFF' position.
3. Disconnect the regulator from the gas cylinder. Inspect the hose with regulator assembly for cracking, cuts or any other damage, and replace as necessary. *Refer to the Parts List in this operator's manual, pages 24 - 27.*
4. Remove and clean the flame tamers, cooking plates and barbecue burners.
5. Cover each gas valve orifice with aluminum foil.
6. Brush the inside and bottom of the barbecue with a fibre pad or nylon brush and wash with a mild soap and warm water solution. Rinse thoroughly and let dry.
7. Remove aluminum foil from orifices and check each orifice for obstruction.
8. Check each spark electrode, adjusting as needed. The space between the spark electrode tip and spark receiver should be approximately 4 - 5 mm.
9. Replace the burners and adjust the gas collector box. The edge of the collector box should be overlapping the burner port.
10. Reconnect the gas source and observe the burner flame for correct operation.
11. Replace flame tamers and cooking plates.



- **BEWARE OF SPIDERS. BURNER TUBES SHOULD BE INSPECTED AND CLEANED PERIODICALLY.**



- **SPIDERS AND SMALL INSECTS CAN OCCASIONALLY SPIN WEBS OR MAKE NESTS IN THE BURNER TUBES. THESE WEBS CAN LEAD TO A GAS FLOW OBSTRUCTION WHICH COULD RESULT IN A FIRE IN AND AROUND THE BURNER TUBES**
- **THIS TYPE OF FIRE IS KNOWN AS 'FLASH-BACK' AND CAN CAUSE SERIOUS DAMAGE TO YOUR BARBECUE AND CREATE AN UNSAFE OPERATING CONDITION FOR THE USER**
- **ALTHOUGH AN OBSTRUCTED BURNER TUBE IS NOT THE ONLY CAUSE OF 'FLASH-BACK' IT IS THE MOST COMMON CAUSE AND FREQUENT INSPECTION AND CLEANING OF THE BURNER TUBES IS NECESSARY.**



- **KEEP BARBECUE AREA CLEAR AND FREE FROM COMBUSTIBLE MATERIALS, GASOLINE AND OTHER FLAMMABLE VAPOURS AND LIQUIDS**
- **DO NOT OBSTRUCT THE FLOW OF AIR FOR COMBUSTION AND VENTILATION**
- **KEEP THE VENTILATION OPENINGS OF THE CYLINDER ENCLOSURE CABINET FREE AND CLEAR OF DEBRIS**
- **VISUALLY CHECK BURNER FLAMES OCCASIONALLY TO ENSURE PROPER FLAME PATTERN AS SHOWN BELOW**
- **FAILURE TO COMPLY WITH THESE INSTRUCTIONS MAY RESULT IN A HAZARDOUS SITUATION WHICH, IF NOT AVOIDED, MAY RESULT IN INJURY.**

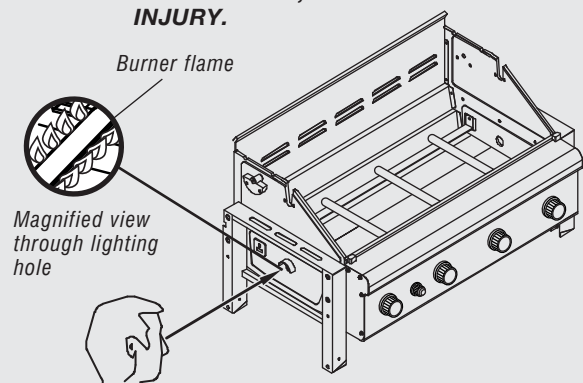

### CLEANING THE BURNER TUBES AND BURNER PORTS

To reduce the chance of FLASHBACK FIRE you must clean the burner tubes as follows at least once a month in summer and fall or whenever spiders are active in your area, and if your barbecue has not been used for an extended period of time.

**NOTE:** An intense yellow flame is generally a sign that the burner needs cleaning.

1. Turn all burner valves to the full 'OFF' position.
2. Turn the LP gas cylinder valve to the full 'OFF' position.
3. Detach the LP gas regulator assembly from your gas barbecue.
4. Remove the cooking plates, flame tamer plates and grease trays from your barbecue.
5. Remove the screw from the rear of each burner using a Phillips-head screwdriver.
6. Carefully lift each burner up and away from the gas valve orifice.
7. Check and clean burner / venturi tubes for insects and insect nests. A clogged tube can lead to a fire beneath the barbecue.
8. Refer to diagram 1 and perform one of these three cleaning methods:

**METHOD 1:** Bend a stiff wire or wire coat hanger into a small hook as shown and run the hook through the burner tube and inside the burner several times to remove debris.



Diagram 1

To clean burner tube, insert hook as indicated by the arrow.

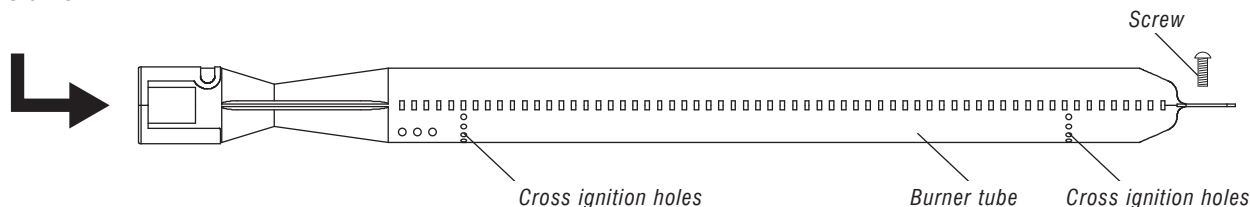

**METHOD 2:** Use a bottle brush with a flexible handle and run the brush through the burner tube and inside the burner several times to remove any debris.

**METHOD 3:** Use an air hose to force air through each burner tube. The forced air should pass debris or obstructions through the burner and out the ports.

Regardless of which burner cleaning procedure you use, we recommend you also complete the following steps to help prolong burner life.

1. Use a fibre pad or nylon brush to clean the entire outer surface of each burner until free of food residue and dirt.
2. Clean any clogged ports with a stiff wire, such as an open paper clip.
3. Inspect each burner for damage (*cracks or holes*) and if such damage is found, order and install a new burner. After installation, check to ensure that the gas valve orifices are correctly placed inside the ends of the burner tubes. Also check the position of your spark electrode.



**FOR SAFE OPERATION ENSURE THE GAS VALVE ASSEMBLY ORIFICE IS INSIDE THE BURNER TUBE BEFORE USING YOUR BARBECUE. See diagram. IF THE ORIFICE IS NOT INSIDE THE BURNER TUBE, LIGHTING THE BURNER MAY CAUSE EXPLOSION AND / OR FIRE RESULTING IN SERIOUS BODILY INJURY AND / OR PROPERTY DAMAGE.**



**BURNER IS TO BE INSTALLED WITH THE CROSS IGNITION HOLES UNDERNEATH.**

***THIS PAGE HAS BEEN LEFT INTENTIONALLY BLANK***

**PARTS LIST**

<b>Ref</b>	<b>Description</b>	<b>Part No.</b>	<b>Qty</b>	<b>Ref</b>	<b>Description</b>	<b>Part No.</b>	<b>Qty</b>
1	Hood plate	P00146049B	1	24d	Manifold tube	P05005182A	1
2	Hood side panel – <i>right</i>	P0010607DJ	1	25	Grease draining tray	P02717147B	1
3	Hood side panel – <i>left</i>	P0010506DJ	1	26	Control knob – <i>main burner</i>	P034194230	4
5	Hood handle	P00205072B	1	27	Grease receptacle	P02701087B	1
6	Hood handle heat-insulating spacer	P06801001A	2	28	Side shelf – <i>left / right</i>	P01101002C	2
7	Protective pad	P05518003I	2	37	Bowl support bracket – <i>left / right</i>	P01306022D	1
8	Temperature gauge	P00601174B	1	39	Door bracket	P03305025D	1
9	Name plate	P00407006S	1	40	Trolley leg – <i>left-front castor side</i>	P00910008C	1
10	Cooking rack / secondary	P01504001E	1	41	Trolley leg – <i>left-back castor side</i>	P00911010C	1
11a	Grill plate	P01602008F	1	42	Trolley leg – <i>right-front wheel side</i>	P00912008C	1
11b	Hot plate	P05702001F	1	43	Trolley leg – <i>right-back wheel side</i>	P00913012C	1
12	Flame tamer	P01705019F	2	44	Trolley bottom shelf – <i>with cylinder hole</i>	P01002050D	1
13	Burner– main	P02008018A	4	45	Trolley side panel – <i>left</i>	P07605009K	1
14	Burner bracket	P02213003B	1	46	Trolley side panel – <i>right</i>	P07606009K	1
15	Cross lighter	P026260014	2	47	Trolley rear panel	P07702046B	1
16	Gas collector with electrode	P026080054	1	48	Castor – 3" <i>with brake</i>	P05106004A	2
17	Electronic wire set	P02615084A	1	49	Wheel	P05101001A	2
18	Electronic igniter – 2 <i>port</i>	P02502172C	1	50	Wheel hub cap	P05122001A	2
19	Bowl panel – <i>right</i>	P00721324A	1	51	Door	P04301025P	2
20	Bowl panel – <i>left</i>	P00720304A	1	52	Door trim plate	P07510012B	2
21	Bowl panel – <i>front</i>	P0073826GA	1	53	Door magnet	P05318022B	2
22	Bowl panel – <i>rear</i>	P0072547GA	1	54	Door spacer	P06801016G	4
23	Control panel – with screen print	P02906181A	1	55	Door handle	P00203009B	2
24	Gas valve manifold assembly	Y0060359	1	57	Lighting stick	P05313023B	1
24a	Gas valve – <i>main, without jet</i>	P03234003A	4	58	Door stop plate	P05523003G	1
24b	Gas jet – <i>main</i>	P06519054A	4	59	Regulator	P03603020A	1
24c	Heat shield	P03006116B	1		Hardware pack	P06003101A	1

**PARTS DIAGRAM**

This diagram is provided to assist you identify parts if replacement is necessary. Contact your place of purchase or the manufacturer to enquire about parts, availability and or service.

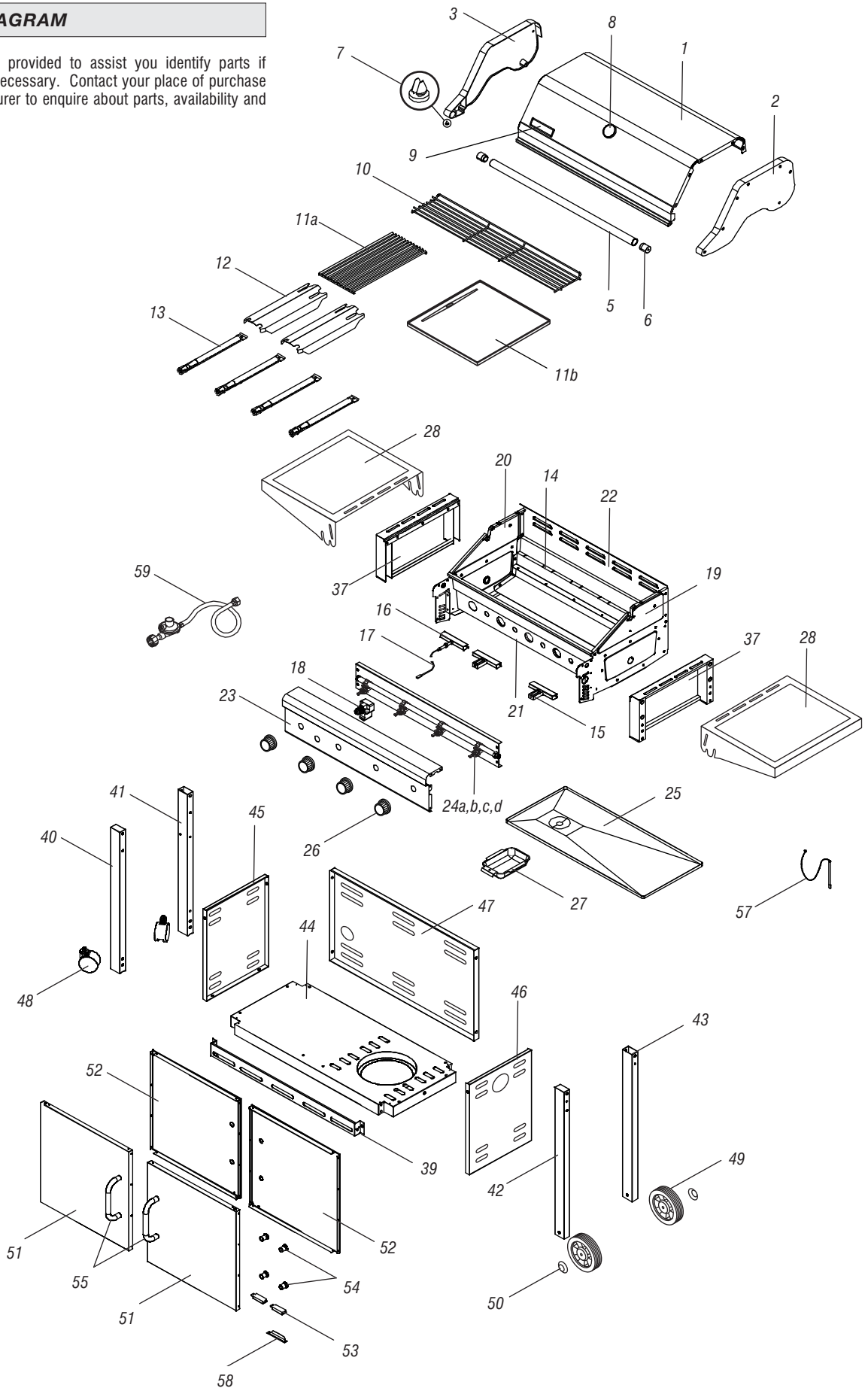

## **PRIVACY POLICY**

Focus Lifestyle Products Pty Ltd may collect personal information about a consumer of its products in the course of receiving or responding to a warranty claim. Such information is only collected to enable the resolution of the warranty claim to the consumer's satisfaction, and is not disclosed to other organisations except service agents or sometimes the applicable retailer.

Focus Lifestyle Products has a Privacy Policy (*which is available on request*), which encompasses compliance with the Privacy Act 1988 (Cth). Importantly, individual consumers generally have a right to access information held about them.

Manufactured by  
Grand Hall Enterprises Ltd China  
for  
Focus Lifestyle Products Pty Ltd

ABN 93 160 136 977

223 - 225 Governor Road, Braeside,  
Victoria, Australia 3195

P.O. Box 532 Mordialloc,  
Victoria, Australia 3195  
[enquiry@focuslifestyle.com.au](mailto:enquiry@focuslifestyle.com.au)  
Tel: 1800 680 405  
Fax: (03) 9587 7965

All specifications are subject to change  
without notice.