

This Owner's Manual is provided and hosted by [Appliance Factory Parts](#).

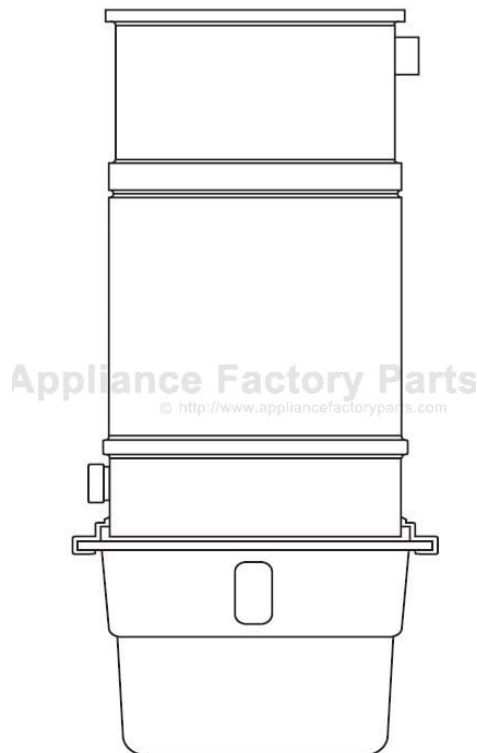

Beam BM1393 Owner's Manual

[Shop genuine replacement parts for Beam BM1393](#)



[Find Your Beam Vacuum Cleaner Parts - Select From 10 Models](#)

----- Manual continues below -----

Beam Central Vacuum System Installation Guide

TOOLS NEEDED FOR INSTALLATION

Drywall saw (optional)

Electrical tape/duct tape/cable ties

Electric drill—1/2" (1.3cm) with right-angle head if possible

Flashlight

Forstner wood-boring bit—2-1/4" (5.7cm)

Hammer

Hole saw or cutter—2-1/4" (5.7cm)

Masonry bit—2-1/4" (5.7cm) (optional)

Metal coat hangers

Pencil

Pipe/tubing cutter or hacksaw and miter box

Safety goggles

Screwdrivers (Phillips and flat blade)

Steel tape measure

Stud finder

Utility/razor knife

Wire stripper/cutter

Wood chisel

30' (9.15m) piece of cord or string

HELPFUL HINTS FOR INSTALLATION

Use a tubing cutter for cleaner cuts.

Use 2-1/4" wood boring bit similar to a Forstner bit.

Rent a right-angle drill if you do not have one.

LOOK FOR OTHER HELPFUL HINTS INSIDE THIS MANUAL.

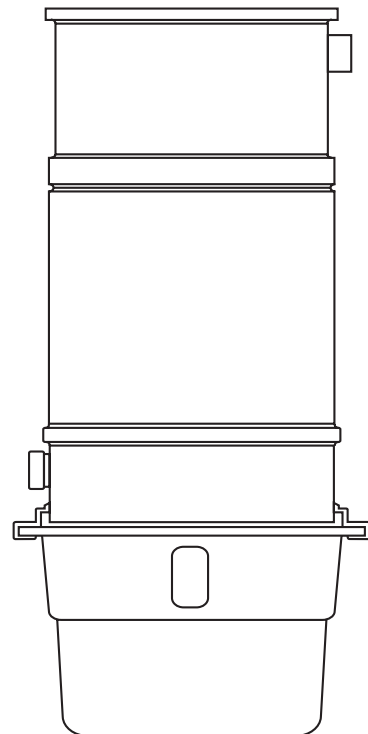

BEAM

CENTRAL VACUUM SYSTEMS

Cleaner, healthier living. Built in.

Index

Typical installations	2
Components of system	3
Seven Step Installation	
Step #1: Choose your system	3
Step #2: Plan number of inlets	4
Step #3: Plan placement of inlets	4
Step #4: Plan tubing installation	5
Step #5: Install inlet valves	
Existing home	5
New construction	8
Step #6: Install tubing	9
Step #7: Install power unit	10
Safety warnings	12

Typical Central Vacuum System Installations

Ranch-style bungalow

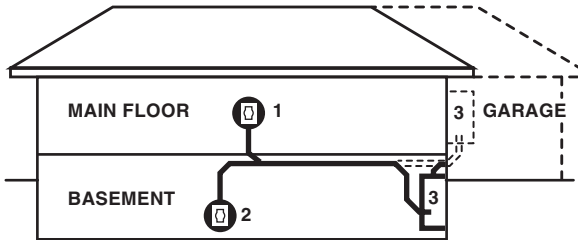

Single story on slab/crawlspace

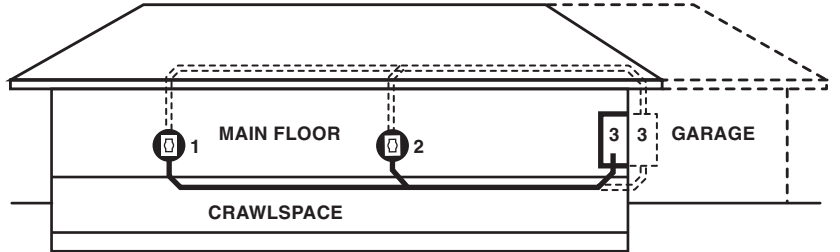

4-level split

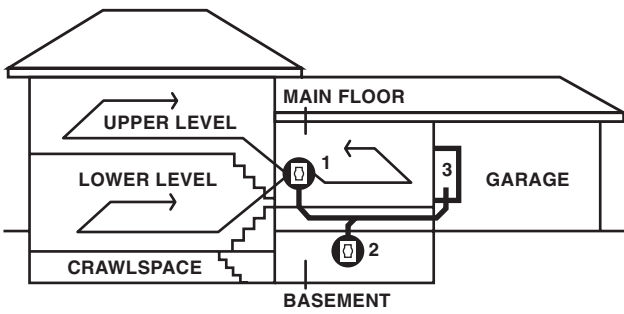

Large 4-level split

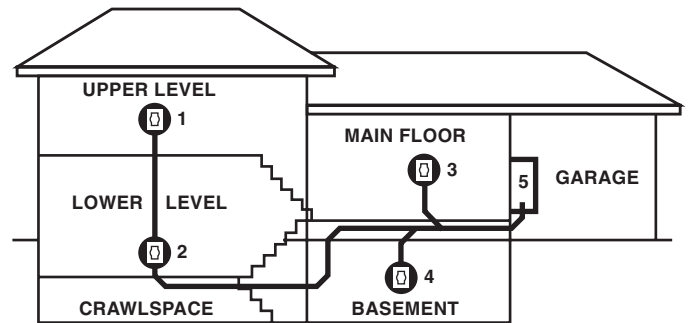

Two-story

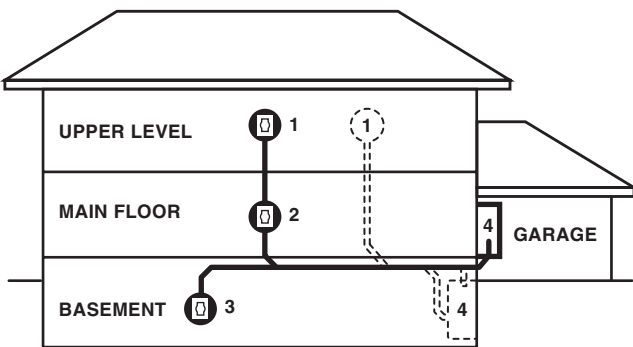

Large 3-level split

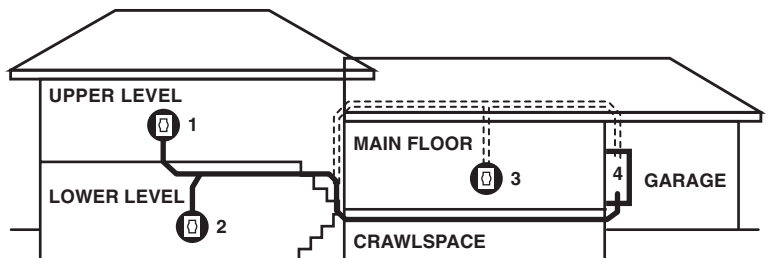

Seven Step Installation

Congratulations on the purchase of your new central vacuum system. It will make cleaning your home easier and improve indoor air quality. The system typically can be installed in virtually any home with no costly alterations and very little mess. This guide will show how to install your central vacuum system in your home in just seven steps.

Before you begin installation, read this guide. Also review local building codes so your installation complies with them.

Components of a central vacuum system installation.

The Power Unit/Dust Collection Receptacle is usually mounted in the garage, basement, utility or storage room to remove dust and allergens from living areas.

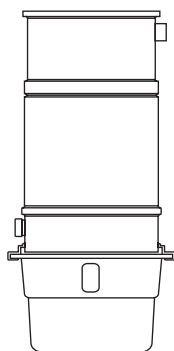

Tubing & Fittings: Dust and dirt are carried through tubing from “inlet valves” to the power unit. **Note: ASTM tubing and fittings are specifically designed for your central vacuum system. Other types of tubing, like plumbing pipe, are different sizes and will not fit.**

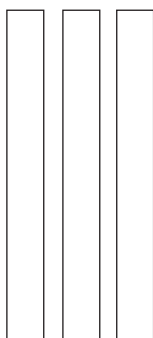

Inlet valves: Installed in the wall or floor, each inlet valve connects the powerhead and flexible cleaning hose to the tubing in your home.

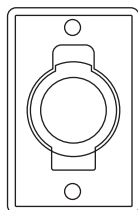

Installation Step 1: Choose your system.

You’ve already completed step number one...you’ve purchased your powerful new system. Next, inventory the component parts that arrived with your central vacuum system kit and assemble the tools you will need. **(See front cover.)**

Inventory all the parts.

Lay out the parts so you know you have them all and what each is called. A three-inlet valve system typically includes:

- 80' low-voltage wire**
- 3 mounting brackets**
- 6 nail guards**
- 3 plaster guards**
- 1-1/4 pint solvent sealer**
- 6 45 degree elbows**
- 9 90 degree sweep elbows**
- 2 90 degree sweep tees**
- 6 stop couplers**
- 3 90 degree dual elbows**
- 6 hanger clamps**
- 6 wire nuts**
- 3 floor mounting adapters**

*Inlet covers sold separately

Installation Step 2: Decide how many inlets you will need.

To make sure your central vacuum system reaches every room throughout the house, you must first determine the number of inlets you will need and where to place them. One inlet valve can serve 700-800 square feet (63-72 sq m). Use only interior walls if possible, so you won't have to deal with insulation typically found in exterior walls.

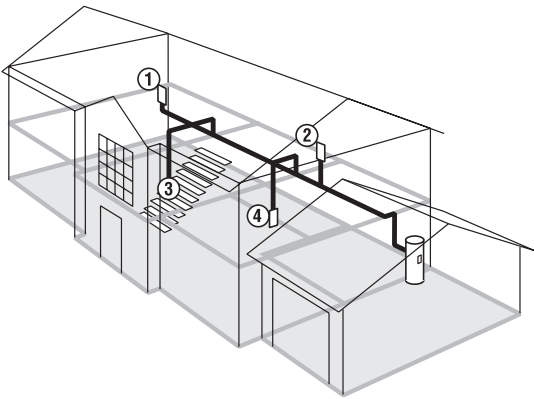

Installation Step 3: Decide where to place inlets.

Good locations are centrally located in hallways or closet walls and/or doorways. Do not place inlets behind doors or furniture.

Existing home: The inlet valve must be within 6 feet (1.83m) of an electrical outlet to provide power to the powerhead. A switch on the handle sends a signal through “low-voltage” (24 volt) wiring to turn the power unit on and off.

New construction: If your home is under construction, you should consider using “electrified” inlet valves. Electrified valves have low-voltage and household wiring connections built in, so there's no need for a nearby electrical outlet. Inlet valves should be installed before drywall is hung. Installation must be coordinated with an electrician to hook up the electrical line after the tubing has been installed (electrified valves sold separately).

Choosing the right spot for the inlet valve.

Use a stud finder, or sound out the wall, to make sure the site for the inlet valve is between the studs and that the space is open behind the wall board. Also check the other side of the wall to make sure it's clear of obstructions such as utilities and outlets. **Caution: Do not install an inlet behind a door or in a wall that has a pocket door.** Then have a helper hold the end of the hose at the proposed site for the inlet valve and take the other end and walk around the room(s). If you have no helper, use a piece of cord or string that is 30 feet (9.15m) long—the length of the hose. You want to be able to reach everywhere from floor to ceiling even with furniture in the way. You may have to choose a different location or add another inlet to cover the entire floor. Remember, one inlet usually lets you cover about 700-800 square feet (63-72 sq m). Repeat this on each floor of your home.

What about installing inlet valves upstairs?

Because there are finished walls above and below the second-floor sole plate, installing inlet valves upstairs can take a little more ingenuity. There are several options: Place an inlet outside a closet wall and then run the tubing through the wall and through the inside of the closet and down (**see Fig. 03, Page 07**).

Another option is to run the tubing up into the attic then across and down to the inlet. Yet another solution is to install the upstairs inlet valve directly into the floor. **Note: Although plastic inlet valves are acceptable as long as they're installed next to the wall where no one will step on them, metal floor inlets provide added durability. Hint: Do not install floor inlets where furniture will be.**

To run tubing through a closet, mount the inlet outside the closet and run tubing into the closet and down through the closet floor.



Deciding where to mount the power unit.

To be sure that dust and dirt are effectively removed from living areas in your home, mount the power unit in your attached garage. If you do not have an attached garage, the basement, utility room, storage room or mud room is the best alternative location. Find a spot that is close to an electrical source, yet with plenty of room for air to circulate on either side of the unit. You'll need a dedicated 15- or 20-amp circuit. Check the owner's manual.

Installation Step 4: Plan the tubing installation.

Before you install tubing to carry dust and dirt to the power unit, plan your route. Run the tubing beneath the sub-floor whenever possible because it makes tubing easier to work with and creates the shortest path between the inlet valves and the power unit. If the tubing has to run next to a water heater or chimney flue—for your safety and to comply with building codes—use metal central vacuum system tubing for that section. **Hint: A local central vacuum system dealer may provide metal tubing.** If the tubing runs through an unheated attic or other unprotected environment, wrap it with insulation to prevent condensation and the possibility of clogging.

Installation Step 5: Install the inlet valves.

Existing home inlet valve installation.

Directly beneath the proposed inlet site, use a flat-bladed screwdriver to wedge the molding aside. Then, take a wire coat hanger and snip a long straight piece from it. Insert the wire into the chuck of your drill and then holding the drill vertically beneath the intended inlet site, slowly drill down into the floor alongside the baseboard or where the wall and floor intersect. Release the wire from the drill chuck and leave it in the pilot hole to serve as a locator. Then go to the basement and look for the wire protruding from the ceiling.

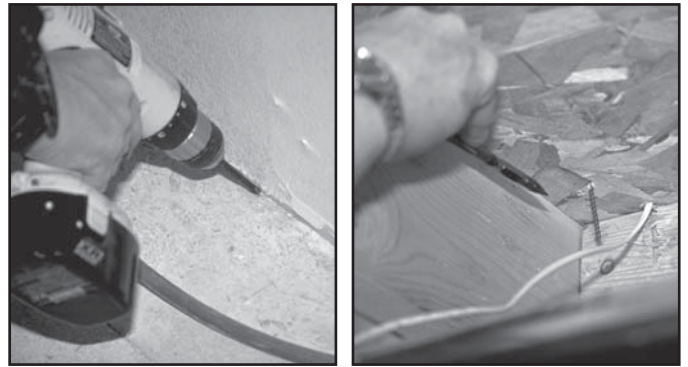

Now you can see where the inlet valve is going to be above you. Measure from the wire to find the center of the sole plate and wall cavity. **Note: You may want to drill a 3/4" (1.9cm) diameter inspection hole to avoid cutting into the bottom of a stud or other inner-wall obstructions.** Then using a flashlight and/or probe, inspect the interior of the wall to be sure there are no obstructions. If there are obstructions, you may have to move the inlet site. If there are no obstructions, drill a 2-1/4" diameter hole (5.7cm) in the bottom of the hollow wall through the sole plate. Make sure to cut in between the walls. The tubing is 2" (5.08cm) in diameter, so the hole will give you room to manipulate the tubing. Again, check for obstructions using a flashlight and a length of tubing. If there are no obstructions, go back upstairs and mark the inlet location on the wall. To do that, at the electrical outlet adjacent to the inlet site, measure up from the floor to the center of the outlet. At the proposed inlet site measure up from the floor the same distance. This will be the center of your inlet valve. If you prefer, you may locate the inlet at a more convenient height. Some homeowners prefer the inlet at fingertip height, about 30" (76.2cm) above the floor.

Installing an inlet valve.

Take a wall mounting bracket, cut or snap off the new construction flange and dispose of it. In new construction, nail the tab to the stud. (See New Construction inlet valve installation.) Use a level to make sure the mounting bracket is level. Then trace the outline of the mounting bracket onto the wall. Take a utility knife and score the lines. Then use the utility knife or a drywall saw to cut a hole through the drywall. **Hint: A drywall saw makes the job easier.**

Attach a 90 degree dual elbow fitting to the flange on the back of the mounting bracket. **Note: The ends of the fitting are different depths to accommodate walls of different widths.** Apply glue around the outside of the mounting bracket flange and twist the 90 degree elbow fitting into place. Make sure the open end faces the direction it will meet the tubing—usually straight down. **Note: If tubing has to run from the attic, the opening of the 90 degree fitting will face upward.** **Caution: Never apply glue to the inside of fittings or tubing.** Apply glue only to the outside of the tubing. This will prevent glue from creating obstructions which could clog your system.

Run about 6" (15.24cm) of low-volt wire through the guide hole in the mounting bracket. Split the wire into two strands and strip 1" of insulation from each strand. Wrap the strands in a clockwise direction around the screws on the back of the inlet valve. Tighten the screws.

Now attach a weight to the end of the low-voltage wire and drop it down to the basement or crawlspace.

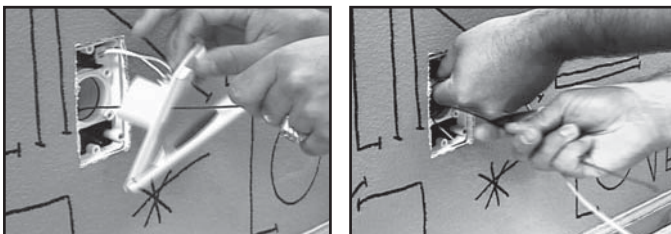

Have a length of wire coat hanger ready with one end bent into a hook. Insert the mounting bracket into the wall hole...first down...then up...centering it. Take

the hanger and insert the hooked end of the hanger into the 90 degree elbow to hold the bracket in place. Then, slide the inlet valve along the wire hanger into the mounting bracket. Screw the valve into place. Remove the wire hook. **Caution: Inlet kits come with a long and a short screw, so be sure to use the short screw in the hole facing the elbow since the long screw could puncture it.** Be sure to mount the inlet valve so the lid pulls down to open. Then apply glue to an adequate length of tubing and aim it upward through the hole in the sole plate and into the 90 degree fitting on the back of the mounting bracket. (See Installation Step #6 for information on installing tubing.)

Need more space?

If you cannot locate a hollow wall, or the space between your walls isn't wide enough, there are two alternatives: One is to run the tubing through a concealed area such as the inside of a closet; then run the tubing downward. Another alternative is to use a floor mounted inlet.

Closet wall installation.

Often the only practical solution is to install your system with the tubing going through a wall into a closet, then down through the closet floor. To use this method, select a suitable inlet valve location outside a closet—exercising the same precautions as for normal wall installation.

Then, using a length of coat hanger, drill a hole through both walls (**Fig. 01**). Hold the wire perfectly horizontal so the interior and exterior holes line up with one another. Check for inner wall obstructions by bending a short length of coat hanger wire at a right angle and twirl the right angle piece inside the wall. If there are no obstructions, drill a 2-1/4" (5.7cm) hole horizontally through both walls.

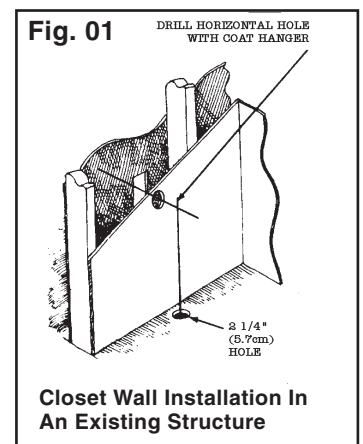

Enlarge the hole in the exterior wall to accommodate the inlet valve assembly (valve and mounting bracket). (As described above in “Installing an inlet valve.”) Inside the closet, drill a pilot hole through the floor beneath the opening in the wall or at a convenient spot nearby to check for obstructions. If there are no obstructions, cut a 2-1/4" (5.7cm) hole through the floor. Run low-voltage wire through the hole in floor, and through the wall to exterior of closet.

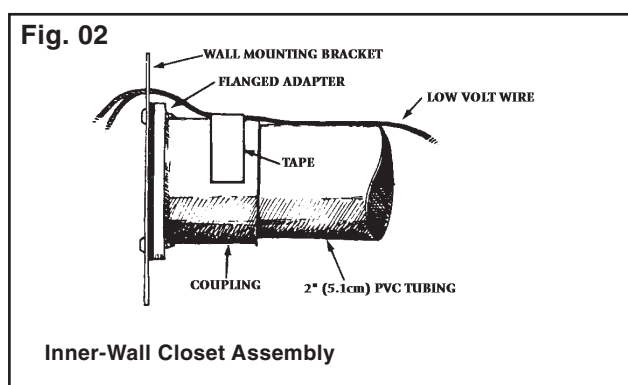

Pass low-voltage wire through the wire guide hole in the inner wall closet assembly (Fig. 02) and tape or cable tie low-voltage wire to this assembly immediately behind the bracket. Attach wires to low-voltage terminals on the back of the inlet valve. Place the inner wall assembly lengthwise through the wall opening and arrange the assembly so the bracket is flush with the inside surface of the wall. Screw the inlet valve to the wall (Fig. 03).

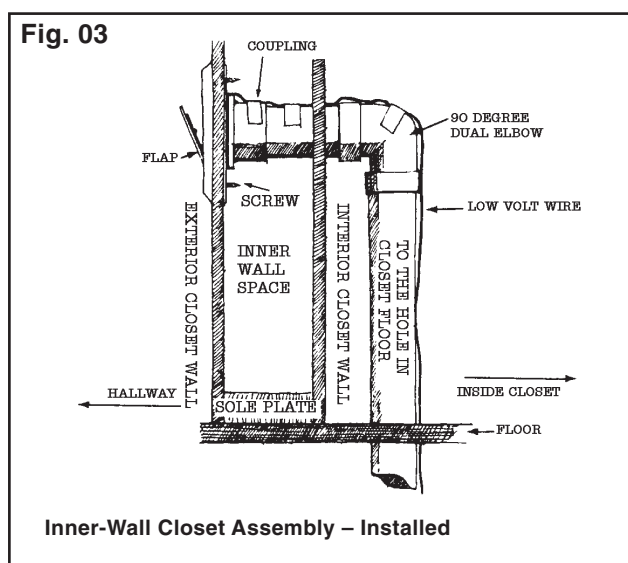

Floor valve installation.

To install a floor inlet valve, drill a pilot hole with a wire coat hanger and check the location as previously described. When you are sure that the proposed location will not be blocked by a joist or other obstruction, cut a hole in the carpet slightly larger than your 2-1/4" (5.7cm) drill bit. Drill a 2-1/4" (5.7cm) hole in the floor. Enlarge the opening to accommodate the low-volt connections. Assemble an adapter reducer bushing and attach the low-volt wire to the inlet valve. Drop the low-volt wire to the basement. Screw the valve to the floor. Repeat until all inlets are installed.

Multi-story homes.

Multi-story homes usually require one or more inlets on each level. Instead of trying to line up inlet valves from one level to the next, run a separate line of tubing from the upstairs inlet valve to a branch line or to the main trunk line (Fig. 04).

Fig. 04

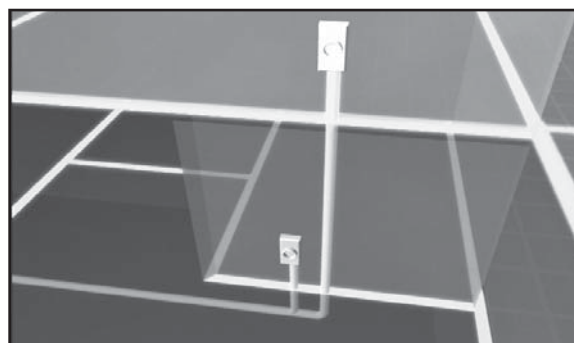

In a two-story home, upstairs beneath the site you've selected for the inlet valve cut a hole just large enough to allow you to reach the second-floor sole plate. **Hint: Cut the hole low in the wall for easier drilling through the sole plate.** Cut a 2-1/4" (5.7cm) hole in the sole plate. Install the inlet valve just as before. Then, from the basement, insert a length of tubing long enough to reach through the hole in the second floor sole plate to the site for the inlet valve. You may have to join several lengths of tubing. Measure and pre-cut these pieces and test-fit them before gluing. When you do apply glue, work quickly to prevent the glue at the top end of the tubing from drying out before it reaches the fitting at the inlet valve.

Remember: Apply glue only to the outside of the tubing.
Hint: When upstairs, remember to aim the elbow downward. Other ways to reach the upstairs in your home are through the interiors of closets or pantries, beneath a staircase, or with floor inlets. If the inlet valve will be serviced from the attic, shorter pieces of tubing joined by couplings may be required because of overhead space restrictions. Again, measure and test fit. When gluing, work quickly to prevent the glue from drying before the tubing reaches the inlet valve.

Installing an automatic sweep inlet.

An automatic sweep inlet — an automatic dustpan — a very popular option for the kitchen, mudroom and bath. Here are some pointers for installation. First, determine the best place to install the sweep inlet — usually beneath a cabinet — and remove any shoe molding. Drill a pilot hole using a length of wire coat hanger and find the wire in the ceiling below. Drill up through the floor beneath the cabinet to check for obstructions and make sure you can connect the tubing to the main line. If there are no obstructions, enlarge the hole in the floor beneath the cabinet and check the clearances.



VacPan



Cut hole 6-3/4" x 1-3/4"
 (17.15cm x 4.45cm)

VacuSweep



Cut hole 6-5/8" x 2-3/8"
 (16.83cm x 6.04cm)

Now, return to the kitchen/mudroom/bath to measure and saw the rectangular hole for the sweep inlet and fasten the inlet into place. In the basement, attach the tubing and string the low-voltage wire just as you would for any inlet. **Hint: See sweep inlet manual for details.**

New construction inlet valve installation.

Select a site for the inlet valve and drill a pilot hole through the floor. Go below to check that the tubing path is clear of present, or future, obstructions such as floor joists, heating ducts, plumbing, wires, etc. At the inlet valve location, drill a 2-1/4" (5.7cm) diameter hole through the sole plate. The hole should be 2" (5.1cm) from the side of the stud and centered between the front and back edges of the sole plate (**Fig. 05**).

Fig. 05

CENTERLINE OF TUBING OPENING IN WALL
 ADAPTER IS 2" (5.1cm) FROM FRONT OF SOLE PLATE
 AND 2" (5.1cm) FROM SIDE OF STUD

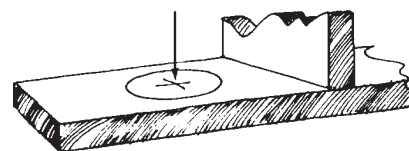

Glue a length of tubing into a stud-mounting bracket assembly. Cut a length of low-voltage wiring, bring approximately 6" (15.24cm) through top wire guide hole in stud bracket assembly and double it back into elbow hole. Tape wire to tubing at assembly elbow and again close to end, and tuck remaining wire into bottom of tubing. Screw plaster guard onto face of assembly (**Fig. 06**).

Fig. 06

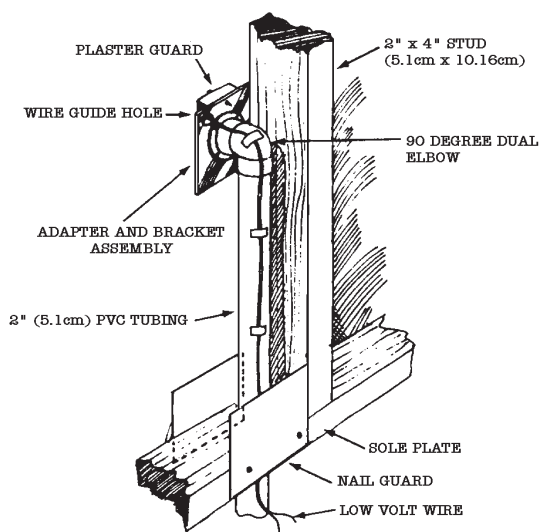

Stud-Mounting Bracket Assembly (New Construction)

Drop bottom of tubing through 2-1/4" (5.7cm) hole and nail stud-mounting bracket assembly to stud. Make sure the center of the inlet hole is at the correct height above floor level and the tubing extends below the sub-flooring. To prevent a nail or screw from penetrating the vacuum tubing, install nail guards on the sole or top plates adjacent to the tubing. See "Installation Step Six: Install the tubing" and complete tubing installation as much as possible. After the walls are finished and painted, plaster guards can be removed and inlet valves installed. The tubing system may be completed at that time and the power unit installed.

Installation Step 6: Install the tubing.

(Existing Home or New Construction)

Beginning at the inlet farthest from the power unit, temporarily fasten tubing for the main trunk line into position. **Hint: Loop string or low-voltage wire to create a hanger strap from a nail or overhead pipe, etc., to cradle the tubing — holding it in position while you work.**

Push a length of tubing up into bottom of the elbow on the inlet valve assembly. Piece together sections of tubing without glue at first to make sure things fit properly. Mark the connections so you can re-assemble them the same way. Remember, the tubing enters the fitting approximately 3/4" (1.9cm). Measure, cut, and de-burr tubing, and, using a 90 degree sweep elbow, slip-fit the vertical tubing line to the main horizontal line. To avoid potential clogging problems when installing tubing and fittings:

- Make straight cuts on tubing (pipe/tubing cutter works well).
- Remove burrs from ends of tubing.
- Be sure tubing fits against the shoulder of the fitting with no gaps.
- Glue only the outside edge of the tubing before assembly into fittings.

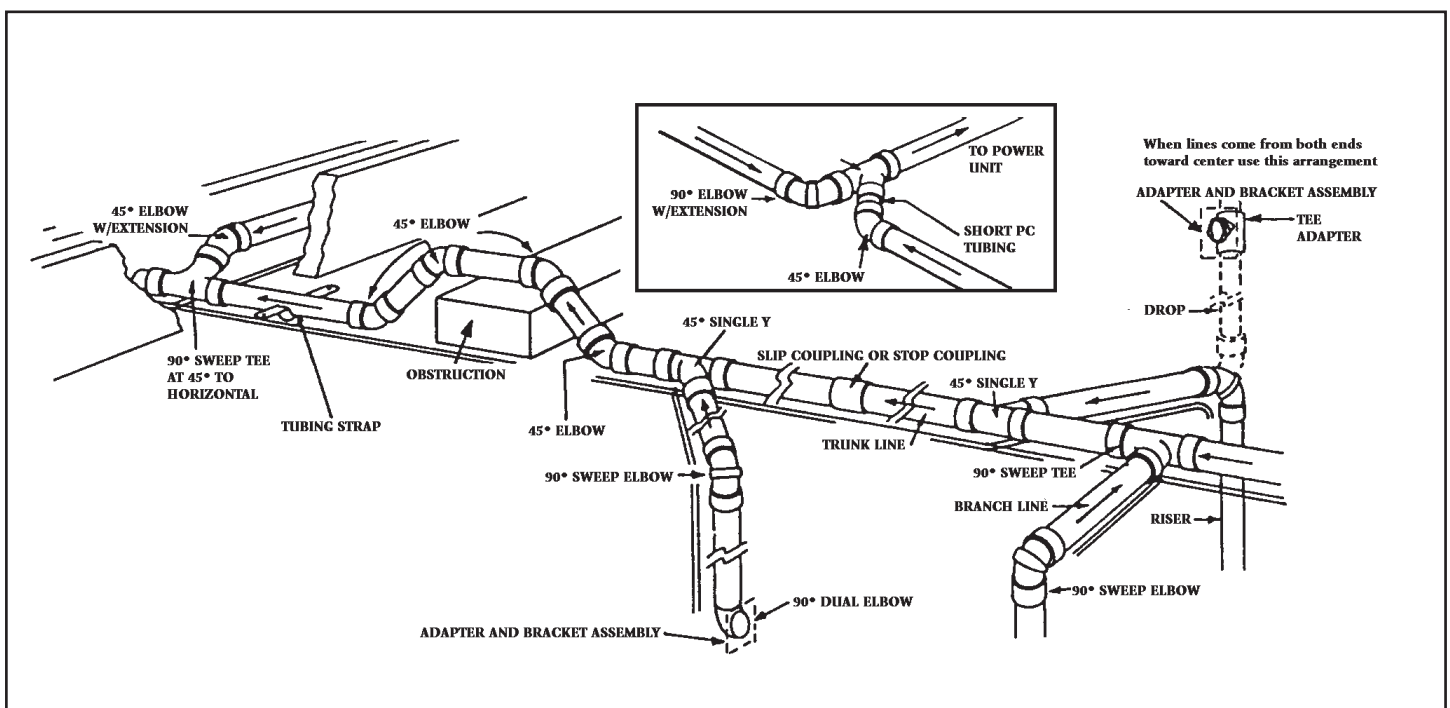

Connect tubing from additional inlet valves to the main trunk line using 90 degree sweep tee elbow fittings. **(Fig. 07)** and use clamps to hold the sections in place. Be sure to install the sweep tee fittings so the sweep is toward the power unit **(Fig. 08)**. Always run branch lines from the sides or top of the main trunk line, never out of the bottom because this will create a trap for dirt to fall into.



Hint: Create clamps from extra tubing to hold low-voltage wire in place.

Masonry or concrete walls.

If you have to run tubing through masonry or concrete walls, rent a hammer drill and/or masonry hole saw. Run the tubing through and patch the hole once you're up and running. Before drilling, check local building codes for special firewall penetration regulations. The code also should tell you if steel tubing is required.

Installation Step 7: Install the power unit.

Attach the power unit to the wall with the bottom screws of the mounting bracket located 48" (1.2m) above the floor to allow easy removal of the dirt canister. For proper motor cooling, there must be at least 12" (30.48cm) between the unit and the ceiling. Do not install the power unit where the ambient temperature regularly exceeds 120 degrees Fahrenheit (48.9 degrees C).

If mounting on plaster, wall board or panel walls, be sure mounting bolts enter studs. If mounting on a block or concrete wall, drill the holes with a masonry bit and insert plastic or lead anchors. As an alternative to mounting on concrete walls, suspend 2" x 4" (5.1cm x 10.16cm) studs or plywood from overhead.

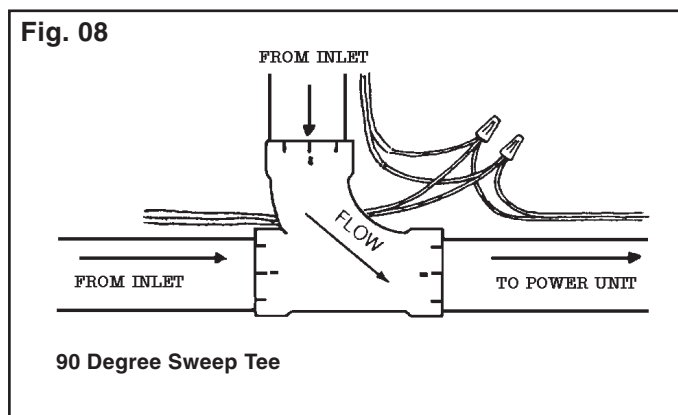
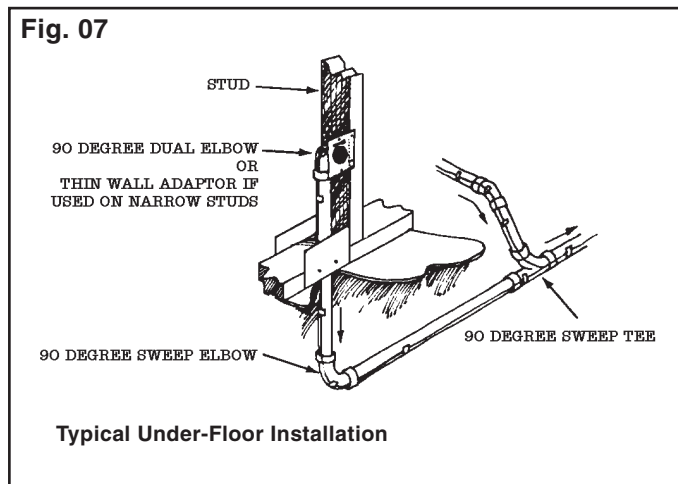

String the low-voltage wire along as you assemble the tubing. Join or splice low-volt wires with wire connectors at each junction or branch in the tubing. To make sure the polarity is right, always attach wires of the same color to each other — typically copper-to-copper and silver-to-silver. Proceed until the tubing system is complete.

To attach the low-voltage wires, strip the wire and crimp the strands into the two “slip-on” terminals provided. Attach the terminals and plug the power unit into the dedicated electrical outlet. The sentry light should come on. Flip the switch and the power unit should come to life. Attach the remaining section of tubing to the power unit with connector/s and clamp/s provided. **Caution: Do not glue the connection because you may need to disconnect the system at a future date.** For added installation convenience, some power units may have inlet connections on either side. If your system came with a muffler, clamp it to the exhaust port.

NOTE: Unit may be exhausted to exterior. Use the same tubing and fittings. If vented, the exhaust air should not be vented into a wall, ceiling or concealed space of a building. Venting over 10 feet (3m) is not recommended.

Power unit electrical wiring.

Check local codes but use not less than #14-3 wire. Plug power unit cord into appropriate 120/220/230/240V — 50/60 cycle electrical outlet. Be sure line voltage is sufficient to handle a 15- or 20-amp load. See your owner’s guide.

Check your installation to make sure it works properly.

All that’s left to do is check the quality of your installation. First, check to see if you have a closed system; with no hose or handle attached, and all inlet valves closed, there should be little or no air coming through the exhaust on the power unit when it is turned on. Second, with the system still running, walk through your home. If you hear whistling or hissing, you may have forgotten to glue a connection. Check basement and attic areas, too. Third, have a helper plug the hose into each of the inlet valves to be sure you can turn the power on. Turn off the switch on the hose handle and the unit should turn off.

That’s it! You’ve just installed your own central vacuum system.

You’ve just made cleaning easier... while improving the air quality in your home. Congratulations!

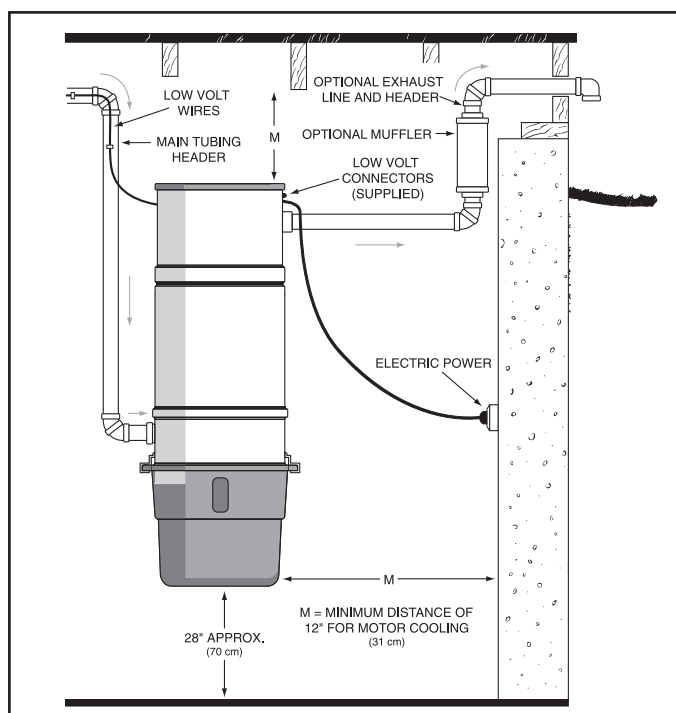

WARNING: ELECTRIC SHOCK COULD OCCUR IF USED ON WET SURFACES.

GROUNDING INSTRUCTIONS

This appliance must be grounded. If it should malfunction or break down, grounding provides a path of least resistance for electric current to reduce the risk of electric shock. This appliance is equipped with a cord that has an equipment-grounding conductor and grounding plug. The plug must be plugged into an appropriate outlet that is properly installed and grounded in accordance with all local codes and ordinances.

WARNING

Improper connection of the equipment-grounding conductor can result in a risk of electric shock. Check with a qualified electrician or service person if you are in doubt as to whether the outlet is properly grounded. Do not modify the plug provided with the appliance—if it will not fit the outlet, have a proper outlet installed by a qualified electrician. This appliance is for use on a nominal 120-volt circuit and has a ground plug that looks like the plug illustrated in **(Fig. 09)** for North American units. For 220/230/240 volt units, consult your local building code/electrician. Make sure that the appliance is connected to an outlet that has the same configuration as the plug. No adapter should be used with this appliance. Check power unit On/Off switch and all inlet valves for operation. This power unit is intended for household and commercial use.

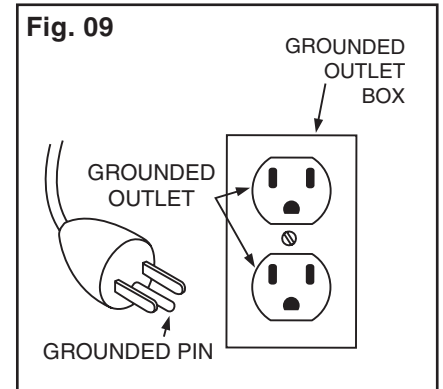

Read all instructions before using this vacuum.

NOTE: Your central vacuum system is listed and approved by the appropriate agencies for dry pick-up only. Please see your rating plate for details. To reduce the risk of electric shock, DO NOT USE outdoors or on wet surfaces.

IMPORTANT SAFETY INSTRUCTIONS

When using electrical appliances, basic safety precautions should always be followed, including the following:

DANGER: Always unplug power unit from the electrical outlet before servicing and cleaning.

WARNING: To reduce the risk of burns, fire, electric shock or injury to persons:

1. Keep cord away from heated surfaces.
2. Do not allow to be used as a toy. Close supervision is necessary when this vacuum is used by or near children.
3. Use this vacuum only for its intended use as described in the operating and maintenance manual. (Use of attachments not recommended by the manufacturer may cause fire, electric shock or injury.)
4. Never operate this vacuum if it has a damaged cord or plug, if it is not working properly or if it has been dropped or damaged. Return to service center or have service person examine and repair.
5. Do not pull or carry this power unit by supply cord, use cord as a handle, close a door on cord or pull cord around sharp edges or corners.
6. Never disconnect plug by pulling on cord. To disconnect from outlet, grasp the plug, not the cord.
7. Do not put any object into openings. Do not use with any opening blocked; keep free of dust, lint, hair and anything that may reduce air flow.
8. Keep hair, face, fingers and loose clothing away from any openings.
9. Do not pick up cigarettes, live hot ashes, matches or similar materials.
10. Never operate vacuum without dust bag and/or filter in place.
11. To disconnect, turn all controls to the OFF position; then remove plug from outlet.
12. Never handle plug, cord or power unit with wet hands.
13. Electric shock could occur if used on wet surfaces.
14. Use extra care when cleaning on stairs.
15. Do not use to pick up flammable or combustible liquids such as gasoline or use in areas where they may be present.
16. For a grounded appliance: Connect to a properly grounded outlet only. See grounding instructions.

SAVE THESE INSTRUCTIONS

Beam Industries | **www.beamvac.com** | **1-800-369-2326**

Technical support is available at **1-866-831-2303** Monday–Friday 8:00am–4:30pm cst.

BEAM
CENTRAL VACUUM SYSTEMS

Cleaner, healthier living. Built in.

©2005 Electrolux Home Care Products Ltd., #075020.3-2005