

This Owner's Manual is provided and hosted by [Appliance Factory Parts](#).

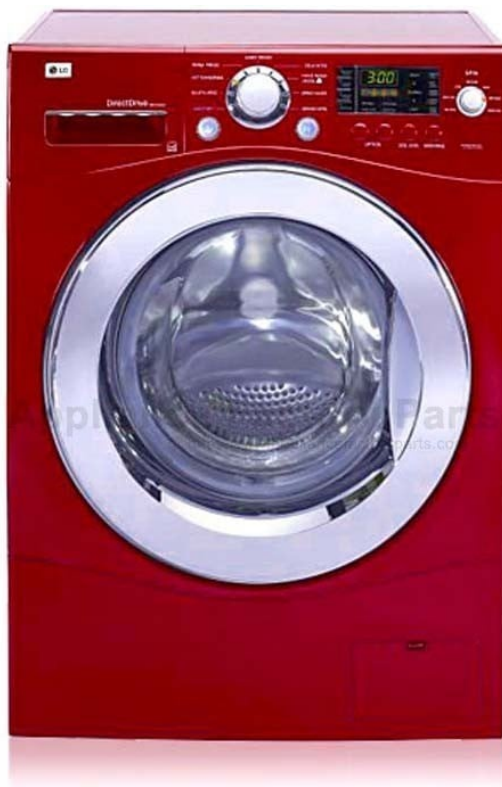

LG WM1355HR Owner's Manual

[Shop genuine replacement parts for LG WM1355HR](#)



[Find Your LG Washer Parts - Select From 393 Models](#)

----- Manual continues below -----



WASHING MACHINE SERVICE MANUAL

CAUTION

READ THIS MANUAL CAREFULLY TO DIAGNOSE TROUBLES
CORRECTLY BEFORE OFFERING SERVICE.

MODEL : WM1355HR / WM1355HW

CONTENTS

1. SPECIFICATION.....	3
2. FEATURES & TECHNICAL EXPLANATION	4
3. PARTS IDENTIFICATION	6
4. INSTALLATION.....	7
5. OPERATION.....	10
6. WIRING DIAGRAM / PROGRAM CHART	12
7. TROUBLE SHOOTING.....	13
7-1.BEFORE SVC CHECKING.....	13
7-2.QC TEST MODE.....	13
7-3.HOW TO KNOW THE WATER LEVEL FREQUENCY.....	13
7-4.HOW TO KNOW TO TEMPERATURE OF EACH THERMISTOR AT OPERATING CONDITION.....	13
7-5.ERROR DISPLAY	14
8. ERROR DIAGNOSIS AND CHECK LIST	16
8-1. DIAGNOSIS AND ANSWER FOR ABNORMAL OPERATION.....	16
8-2. FAULT DIAGNOSIS AND TROUBLE SHOOTING	19
9. DISASSEMBLY INSTRUCTIONS	25
10. EXPLODED VIEW AND PARTS LIST	33
10-1. THE EXPLODED VIEW OF CABINET ASSEMBLY	33
10-2. THE EXPLODED VIEW OF CONTROL PANEL AND DISPENSER ASSEMBLY	34
10-3. THE EXPLODED VIEW OF DRUM AND TUB ASSEMBLY	35

1. SPECIFICATION

ITEM		WM1355HR / WM1355HW
POWER SUPPLY		120V~, 60Hz
PRODUCT WEIGHT		72 kg
ELECTRICITY CONSUMPTION	WASHING	140W
	SPIN	440W
	DRAIN MOTOR	40W
	WASH HEATER	2000W
REVOLUTION SPEED	WASH	50rpm
	SPIN	No Spin/400/600/800/1000/1200/1400
OPERATION WATER PRESSURE		0.3–10kgf/cm ² (30–1000kPa)
CONTROL TYPE		Electronic
WASH CAPACITY		Refer to the Rating Label
DIMENSION		600mm(W)x640mm(D)x850mm(H)
WASH PROGRAM		Cotton, Cotton Quick, Synthetic, Delicate, Wool, Hand Wash, Quick30, Baby Care
RINSE		Normal, Rinse ⁺ , Rinse ⁺⁺ , Rinse+Hold, Normal+Hold
DOOR SWITCH TYPE		Bi-Metal type
WATER LEVEL		10 steps (by sensor)
RESERVATION		From 3 hours to 19 hours
SENSING OF THE LAUNDRY AMOUNT		Adapted
FUZZY LOGIC		Adapted
DISPLAY OF THE REMAINING TIME		Adapted
ERROR DIAGNOSIS		10 items
POWER AUTO OFF		Adapted
CHILD LOCK		Adapted
AUTO RESTART		Adapted
TIME SAVE		Adapted

2. FEATURES & TECHNICAL EXPLANATION

2-1.FEATURES



- **Direct Drive System**

The advanced Brushless DC motor directly drives the drum without belt and pulley.



- **Water Circulation**

Spray detergent solution and water over the load over continu. Clothes are soaked more quickly and thoroughly during wash cycle. The detergent suds can be removed more easily by the water shower during rinse cycle. The water circulation system uses both water and detergent more efficiently.



- **Built-in Heater**

Internal heater automatically heats the water to the best temperature on selected cycles.



- **Child Lock**

The Child lock prevents children from pressing any button to change the settings during operation.



- **More economical by Intelligent Wash System**

Intelligent Wash System detects the amount of load and water temperature, and then determines the optimum water level and washing time to minimize energy and water consumption.



- **Low noise speed control system**

By sensing the amount of load and balance, it evenly distributes load to minimize the spinning noise level.



- **Safety device (Aqua lock)**

Aqua lock System is designed for detecting water leak during operation to prevent water from spilling on the floor.



- **Automatic Wash Load Detection**

Automatically detects the load and optimizes the washing time.

2-2.DETERMINE WASHING TIME BY FUZZY LOGIC

To get the best washing performance optimal time is determined by sensing of water temperature, selected washing temperature and laundry amount.

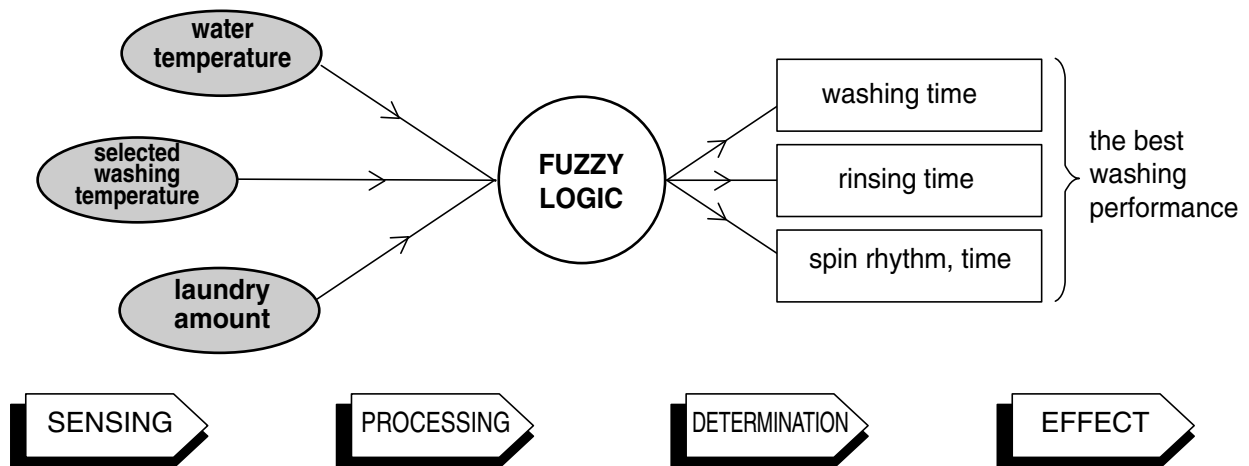

2-3.WATER LEVEL CONTROL

- This model adopts a pressure sensor which can sense the water level in the tub.
- Water supply is stopped when the water level to the preset level, then washing program proceeds.
- Spinning does not proceed until the water in the tub reduces to a certain level.

2-4.THE DOOR CAN NOT BE OPENED

- While program is operating.
- While **Door Lock** light turns on.

3. PARTS IDENTIFICATION

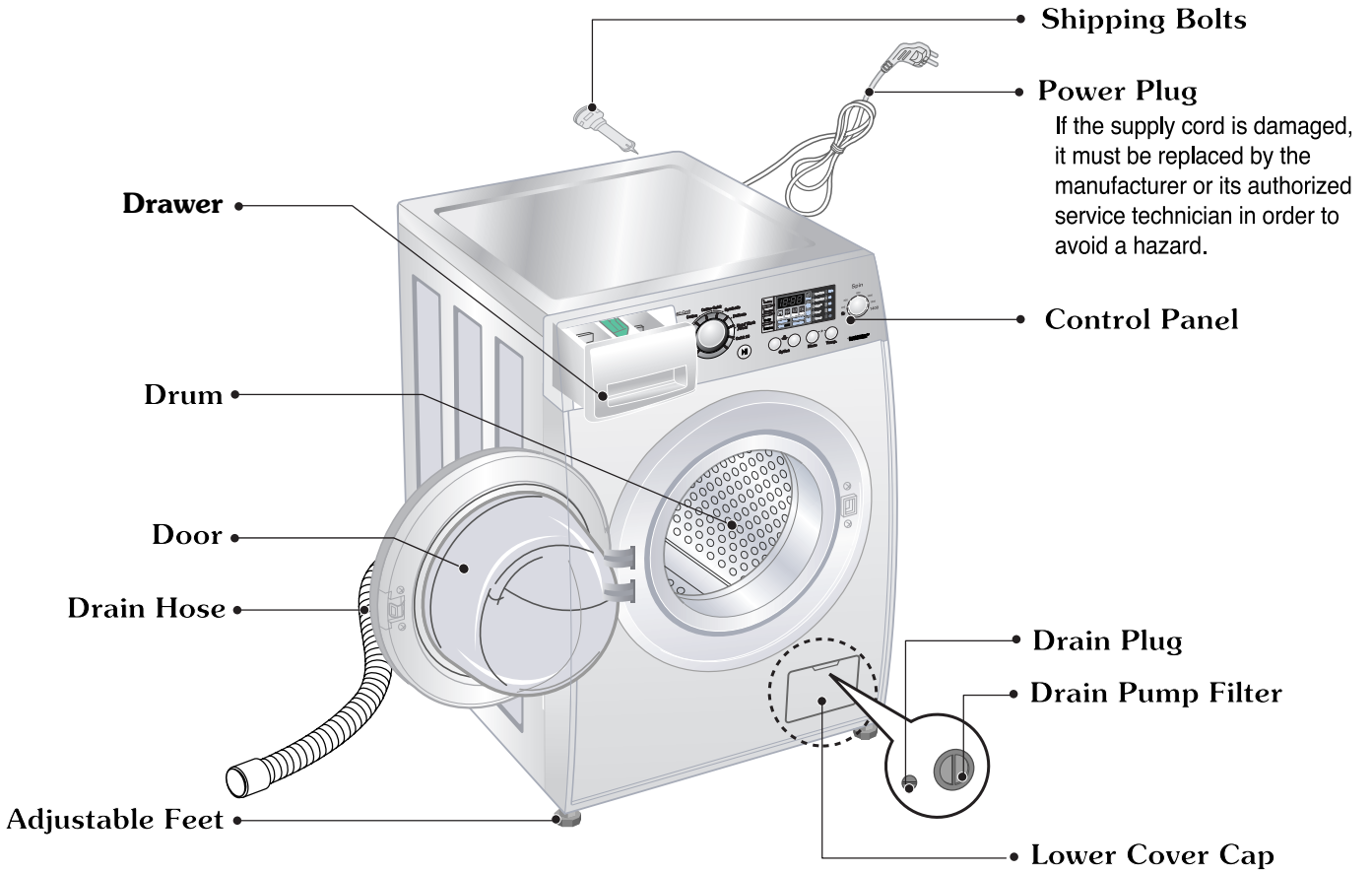

ACCESSORIES

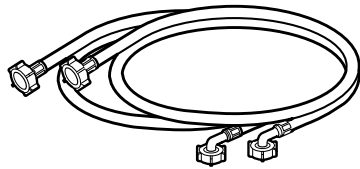

Inlet hose(1EA) ※ Option : Hot/Cold(2EA)

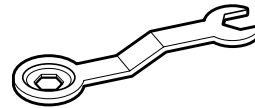



Spanner

4. INSTALLATION

- ① Before servicing ask the customer what the trouble is.
- ② Check the adjustment(power supply is 220-240V~, remove the transit bolts....)
- ③ Check the troubles referring to the trouble shooting.
- ④ Decide service steps referring to disassembly instructions.
- ⑤ And then, service and repair.
- ⑥ After servicing, operate the appliance to see whether it works O·K or NOT.

■ STANDARD INSTALLATION

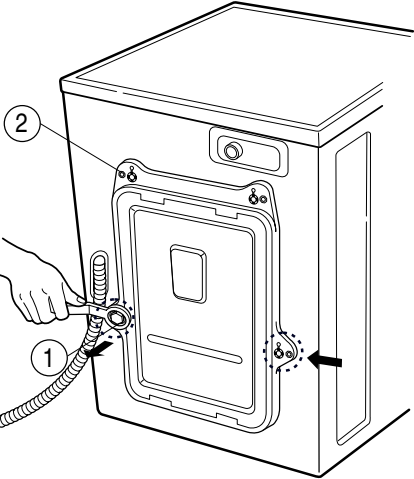
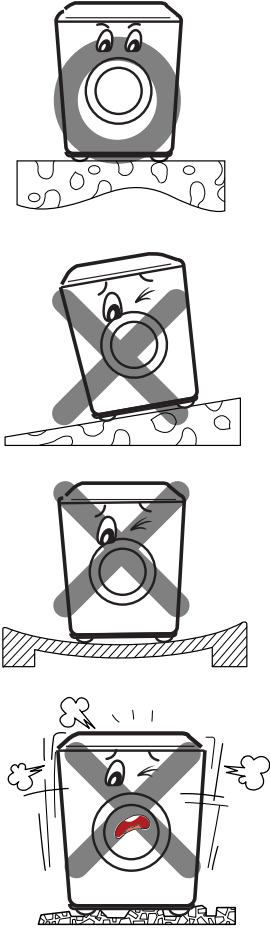
The appliance should be installed as follows.

REMOVE THE TRANSIT BOLTS	INSTALL THE APPLIANCE ON FLAT AND FIRM SURFACE	ADJUST THE HORIZONTAL
<ul style="list-style-type: none"> • Remove the transit bolts (4EA:①)with supplied spanner. • Keep the transit bolts and spanner for future use. • Insert the provided 4 caps into the hole 		<ul style="list-style-type: none"> • Turn the leveling feet to set the appliance horizontally.  <ul style="list-style-type: none"> • The appliance goes up by rotating the feet clockwise. • The appliance come down by rotating the feet counter clockwise.

■ HOW TO CONNECT INLET HOSE

- Check that the rubber packing is inside of the valve connector.
- Connect the inlet hose firmly to prevent leak.



■ CONNECT DRAIN HOSE

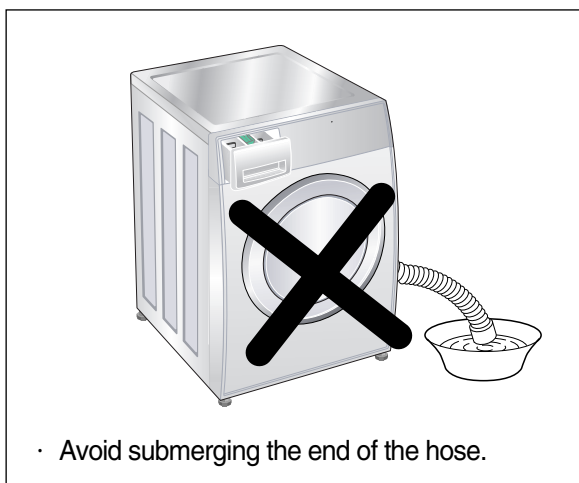
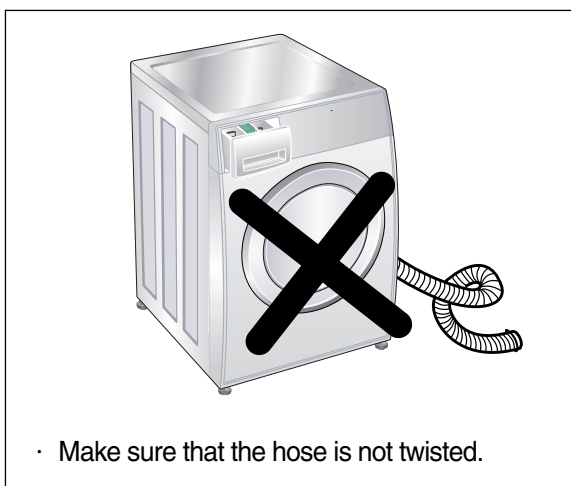

※ The drain hose should be placed under 100cm from the floor.

■ CONNECT POWER PLUG

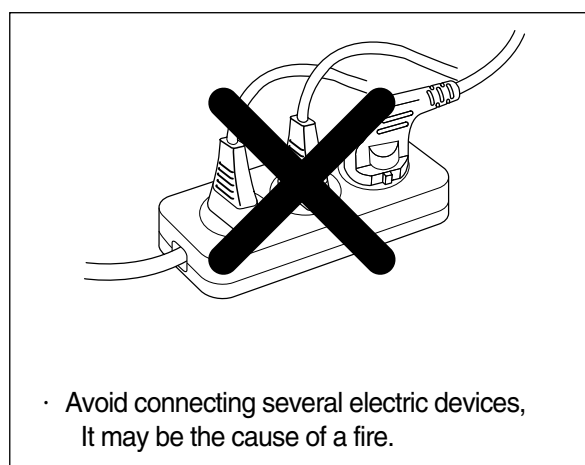
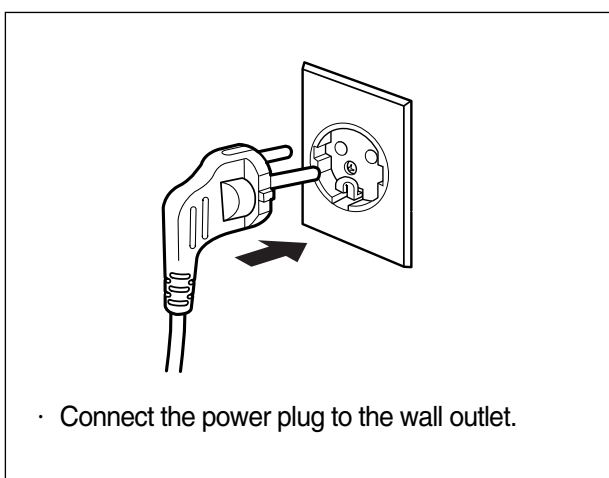

7 TEST OPERATION

1 Preparation for washing.

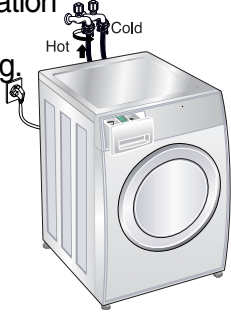

- Connect the power plug to the outlet.
- Connect the inlet hose.

2 Press the POWER button.



3 Press the Start/Pause button.



- In case of Coloreds program.

6 Check the water heating.



- Press the Rinse+Medic Rinse button simultaneously and the present temperature will be displayed.

5 Check automatic reverse turn.



- Check if the drum rotates clockwise and counterclockwise.

4 Check the water supply.

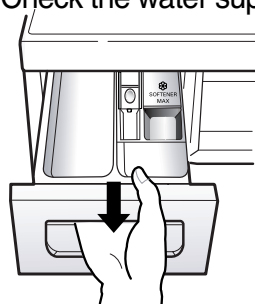

- Check if water is supplied through the detergent dispenser.

7 Check drain and spin

- Turn off Wash and Rinse after pressing the Start/Pause button and start the machine again.
- Check drain and spin.

8 Power off and open the door



- Power off and then power on.
- Check if the door can be opened after 3 minutes.

9 Water removal

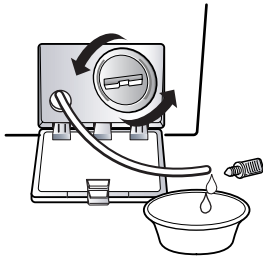

- If SVC is needed during check, remove the remaining water by pulling out the hose cap.

5. OPERATION

Cycle Selector

- Rotate the **Cycle selector knob** to select the cycle designed for different types of fabric and soil levels.

Additional programs

- Time Delay : Allows the start of any cycle to be delayed for 3~19 hours.
- Favorite : Favorite program allows you to store a customized operation for next use.
- Intensive : If the laundry is heavily soiled “Intensive” option is effective.
- Medic Rinse : For high effectiveness or more purity in rinse operation you can choose Medic Rinse option. Medic Rinse is default in Baby Care program.

Power

- Use this button to turn the power **On/Off**.



Start/Pause

- Use this button to Start/ Stop the washer.

Option Button

- Pre Wash : If the laundry is heavily soiled, “Pre Wash” Cotton is recommended.
- Soak : Use this mode to wash normal clothes or thick and heavy clothes which are excessively dirty.
- Crease Care : If you want to prevent crease, select Crease Care button.
- Rinse + Spin : Use this option to rinse and then spin.

6. WIRING DIAGRAM / PROGRAM CHART

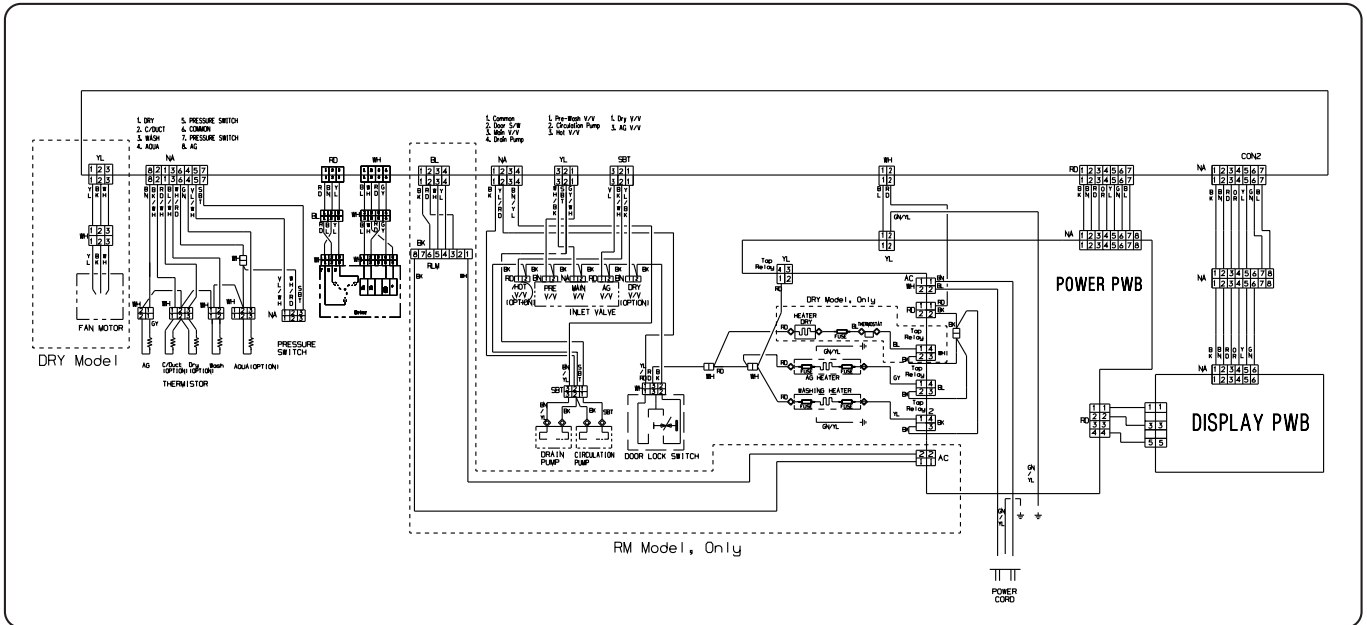

PRGRAM CHART

* Water Supply : W-S

* Intermittent Spin : I-S

* Disentangle : D-T

CYCLE STEP COURSE TIME (SEC.)	Wash				Rinse												Spin			A U T O O F F E N D 29	**Approx Working Time (Minute)								
	Pre		Main		1		2		3		Extra & Stain(4-6)		Spin																
	W / S	Wash	Drain	I / S	W / S	Heat	Wash	Drain	I / S	W / S	Rinse	Drain	I / S	W / S	Rinse	Drain	Spin	D / T											
1	2	3	4	5	6	8	9	10	11	12	13	14	15	16	17	18	19	20	21	22	23	24	25	26	27	28	29		
60		(-)	60	180	120		(-)	60	180	120	180	60	180	120	180	60	180	120	180	60	180	120	180	60	480	180	20	20	
Cotton		8																											1:51
Synthetic		8																											1:34
Cotton Quick		8																											1:31
Delicate																													1:7
Hand Wash		8																											56
Wool																													56
Quick 30																													30
Rinse+Spin																													20
Baby Care		8																											2:27
Wash		8																											68
Spin																													15

- * Basic Cycle
- * Optional Cycle
- * Pre-Setting Time : Water Supply - 120 sec.
Drain - 60 sec.

- * Wash time is in minutes.
- ** The total working time will vary with the load size, water temperature and ambient temperature.

7. TROUBLE SHOOTING

7-1.BEFORE SVC CHECKING

- Be careful of electric shock or disconnecting the parts while trouble shooting.
- Voltage of each terminal in 220-240V~ and DC while applying an electric current.

7-2.QC TEST MODE.

- ① Pressing Option(Left) and Rinse button simultaneously.
- ② Press the Power (Ⓢ) button, while the above condition.
- ③ Press the Start/Pause button as follows.

Number of times the Start/Pause button is pressed	Check Point	Display Status
None	Turns on all lamps and locks the door.	
1 time	Tumble clockwise.	rpm (42~50)
2 times	Low speed Spin.	rpm (55~65)
3 times	High speed Spin.	rpm (125~155)
4 times	Inlet valve for prewash turns on.	Water level frequency (25~65)
5 times	Inlet valve for main wash turns on.	Water level frequency (25~65)
6 times	Inlet valve for hot water turns on.	Water level frequency (25~65)
7 times	Inlet valve for bleach turns on.	Water level frequency (25~65)
8 times	Tumble counterclockwise.	rpm (42~50)
9 times	Heater turns on for 3 sec.	Water temperature
10 times	Circulation pump turns on.	Water level frequency (25~65)
11 times	Drain pump turns on.	Water level frequency (25~65)
12 times	Off	-

7-4.HOW TO KNOW THE WATER LEVEL FREQUENCY

- * Press the Intensive and Option(Left) button simultaneously.

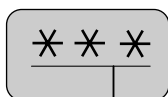











The digits means water level frequency (10⁻¹ kHz)

ex) 241 : Water level frequency = 241×10^{-1} kHz
 =24.1kHz

7-5.ERROR DISPLAY.





- If you press the Start/Pause button in error condition, any error except 'PE' will disappear and the machine will change into pause status.
- In case of 『PE』, 『LE』, if the error is not resolved within 20 sec., and in case of other errors, if the error is not resolved within 4 min., power will be turned off automatically and the error only will be blinked. But in case of 『FE』, power will not be turned off.





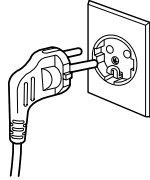
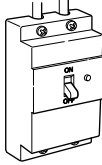

	ERROR	SYMPTOM	CAUSE
1	WATER INLET ERROR		<ul style="list-style-type: none"> • Not reached to the water level(246)within 8 minutes after water supplied or not reached to the preset water level within 25 minutes.
2	DRAIN ERROR		<ul style="list-style-type: none"> • Not fully drained within 10 minutes.
3	OVERFLOW ERROR		<ul style="list-style-type: none"> • Water is over flowing(over 8 level). ※ If "FE" is displayed, drain pump operates to drain water automatically.
4	SENSOR PRESSURE S/W ERROR		<ul style="list-style-type: none"> • The sensor pressure switch is out of order.
5	DOOR OPEN ERROR		<ul style="list-style-type: none"> • In case of operating the reservation function or the other function with door opened. Close the door, then the error display is resolved. • The door switch is out of order.
6	IMBALANCE ERROR		<ul style="list-style-type: none"> • The appliance is tilted. • Laundry is gathered to one side.
7	HEATING ERROR		<ul style="list-style-type: none"> • The THERMISTOR is out of order.

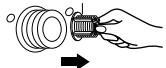
	ERROR	SYMPTOM	CAUSE
8	LOCKED MOTOR ERROR		<ul style="list-style-type: none"> • The connector in the LEAD WIRE ASSEMBLY is not connected to the connector of STATOR ASSEMBLY <ul style="list-style-type: none"> ☞ Reconnect or repair the connector • The hall sensor is out of order/defective. <ul style="list-style-type: none"> ☞ Replace the STATOR ASSEMBLY
9			<ul style="list-style-type: none"> • Water leaks
10	POWER FAILURE		<ul style="list-style-type: none"> • The washer experienced a power failure

8. ERROR DIAGNOSIS AND CHECK LIST

8-1. DIAGNOSIS AND ANSWER FOR ABNORMAL OPERATION

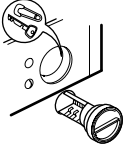
SYMPTOM	GUIDE FOR SERVICE CALL
<p>NO POWER</p>	<div style="display: flex; justify-content: space-between;"> <div style="width: 65%;"> <p>Is the power plug connected firmly to 220-240V~ outlet?</p> <p style="text-align: center;">YES</p> <p>Power failure? or Breaker opened?</p> <p style="text-align: center;">NO</p> <p style="text-align: center;">Visit to check</p> </div> <div style="width: 30%; text-align: center;">   </div> </div>
<p>WATER INLET TROUBLE</p> <div style="text-align: center; margin-top: 10px;">  </div>	<div style="display: flex; justify-content: space-between;"> <div style="width: 65%;"> <p>Is " IE " displayed?</p> <p style="text-align: center;">YES</p> <p>Is the tap opened?</p> <p style="text-align: center;">YES</p> <p>Is the tap frozen?</p> <p style="text-align: center;">NO</p> <p>Is the water supply shut-off?</p> <p style="text-align: center;">NO</p> <p>Is filter in the inlet valve clogged with foreign material?</p> <p style="text-align: center;">NO</p> <p style="text-align: center;">Visit to check</p> </div> <div style="width: 30%; text-align: center;">    <div style="margin-top: 20px; border: 1px solid black; padding: 5px;"> <p>Clean the filter of inlet valve</p>  </div> </div> </div>

SYMPTOM	GUIDE FOR SERVICE CALL
<ul style="list-style-type: none"> • DOOR DOES NOT OPEN • ERROR DISPLAYED ON THE PROGRAM 	<div style="display: flex; justify-content: space-between; align-items: center;"> <div style="width: 60%;"> <p>Started with door opened?</p> <p style="text-align: center;">NO</p> <p style="text-align: center;">Visit to check</p> <p style="text-align: center;"><Check if the door switch is O-K.></p> </div> <div style="width: 35%; text-align: right;"> <p>YES</p>  <p>Close the door</p>  </div> </div>
<ul style="list-style-type: none"> • DRAIN TROUBLE 	<div style="display: flex; justify-content: space-between; align-items: center;"> <div style="width: 60%;"> <p>Is " dE " displayed?</p> <p style="text-align: center;">YES</p> <p>Is the debris filter clogged with foreign material such as pin, coin and etc.?</p> <p style="text-align: center;">NO</p> <p>Is the drain hose frozen with water, kinked or crushed?</p> <p style="text-align: center;">NO</p> <p style="text-align: center;">Visit to check</p> </div> <div style="width: 35%; text-align: right;">  <p>YES</p> <p>Clean up the filter.</p>   </div> </div>
<ul style="list-style-type: none"> • POWER FAILURE 	<p style="text-align: center;">Restart the cycle</p>

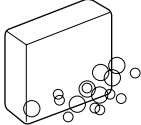
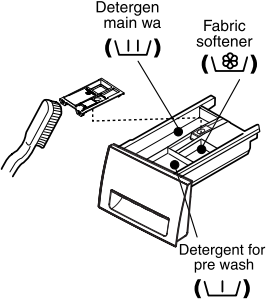
SYMPTOM	GUIDE FOR SERVICE CALL
<p>◦ Suds overflow from the appliance. (In this condition, wash and spin do not operate normally)</p>	<div style="display: flex; justify-content: space-between;"> <div style="width: 65%;"> <p>Is low-sudsing detergent for the drum washing machine used?</p> <p style="text-align: center;">YES</p> <p>Is the proper amount of detergent used as recommended?</p> <p style="text-align: center;">YES</p> <p>Recommend to reduce the using amount of detergent.</p> <ul style="list-style-type: none"> * This appliance has the automatic suds sensing function which operates under much suds condition for good rinse and preventing overflow. * When much suds are sensed, suds removing function such as drain, water input and pause will operate without rotating the drum. </div> <div style="width: 30%; text-align: center;">  <p>LOW-SUDSING</p> </div> </div>
<p>◦ No effect of softener</p>	<div style="display: flex; justify-content: space-between;"> <div style="width: 65%;"> <p>Is softener put in the correct compartment of the drawer?</p> <p style="text-align: center;">YES</p> <p>Is the drawer closed during wash?</p> <p style="text-align: center;">YES</p> <p>Is the softener cap clogged?</p> <p style="text-align: center;">YES</p> <p>Explain how to use softener</p> <p>< Clean the compartment for softener ></p> </div> <div style="width: 30%; text-align: center;">  </div> </div>
<div style="display: flex; flex-direction: column; gap: 10px;"> <div style="display: flex; gap: 10px;"> <div style="border: 1px solid black; padding: 2px 5px;">FE</div> <div style="border: 1px solid black; padding: 2px 5px;">FE</div> </div> <div style="display: flex; gap: 10px;"> <div style="border: 1px solid black; padding: 2px 5px;">FE</div> <div style="border: 1px solid black; padding: 2px 5px;">LE</div> </div> <div style="border: 1px solid black; padding: 2px 5px;">LE</div> </div>	<p style="text-align: center; border: 1px solid black; border-radius: 15px; padding: 10px;">Visit to check</p>

8-2.FAULT DIAGNOSIS AND TROUBLE SHOOTING

CAUTION

1. Be careful of electric shock or disconnecting the parts while trouble shooting.
2. First of all, check the connection of each part terminal with wiring diagram.
3. If you replace the PWB ASSEMBLY, Put in the connectors correctly.

NO POWER

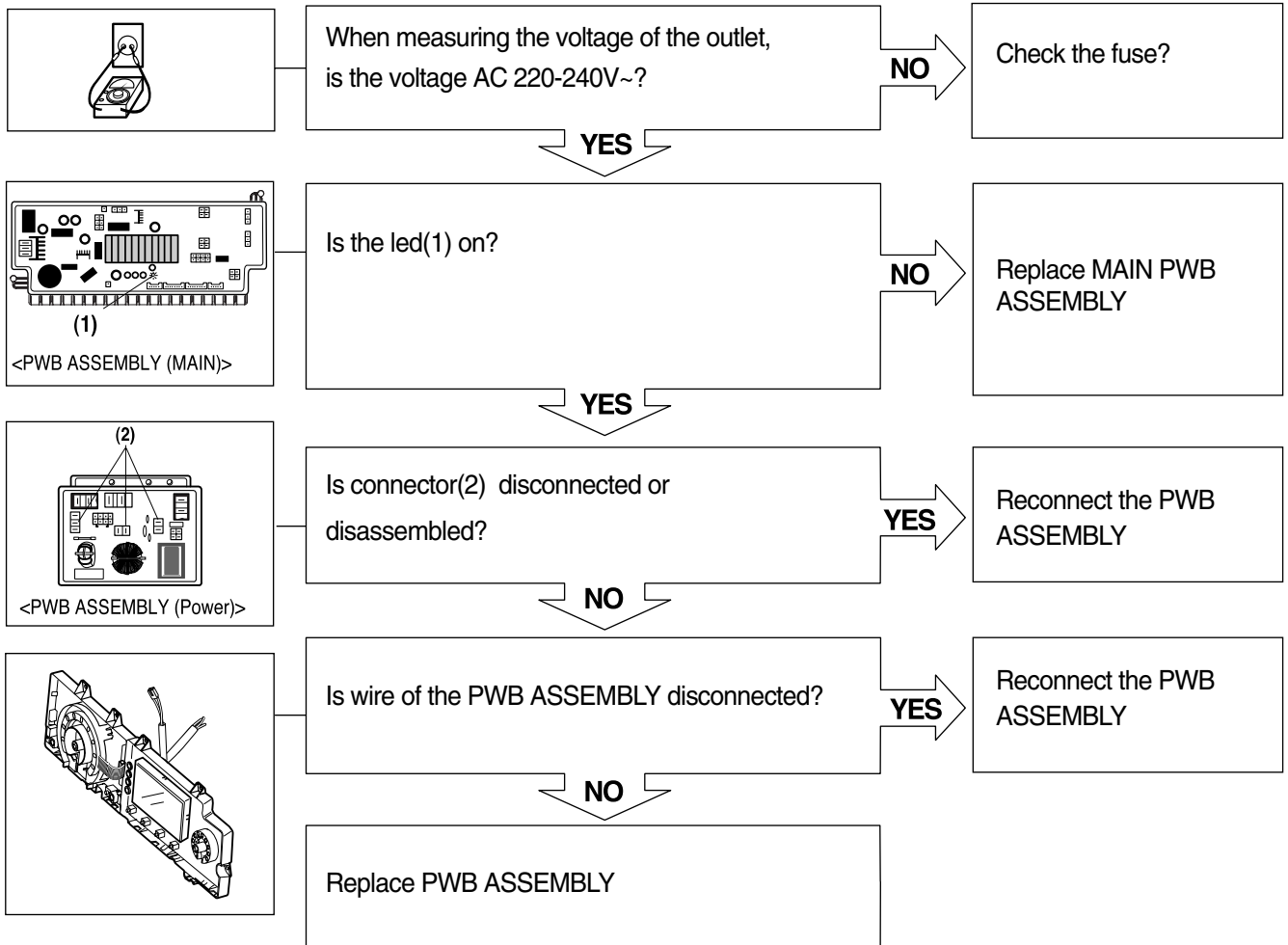

NO WATER SUPPLY

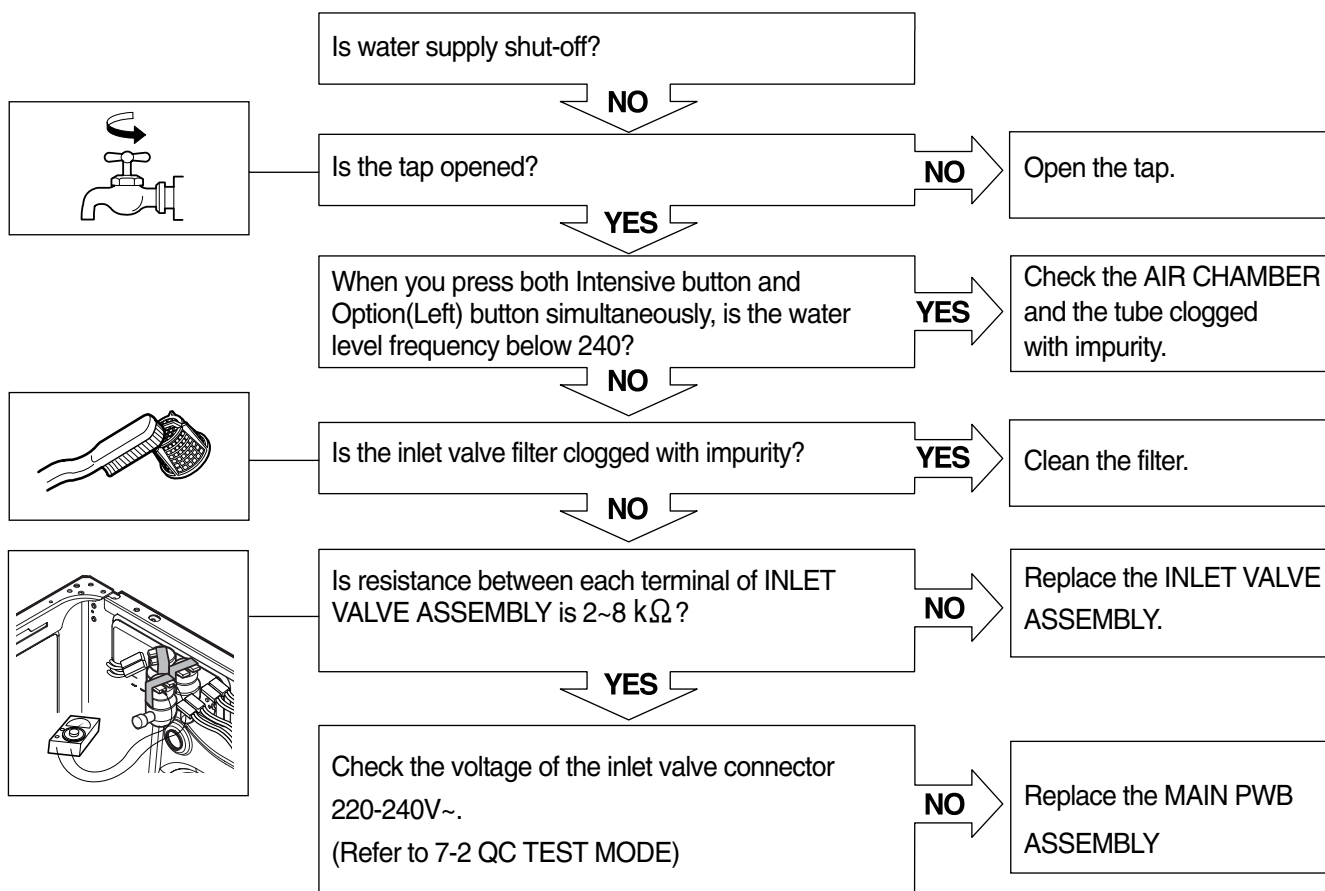

DETERGENT DOES NOT FLOW IN

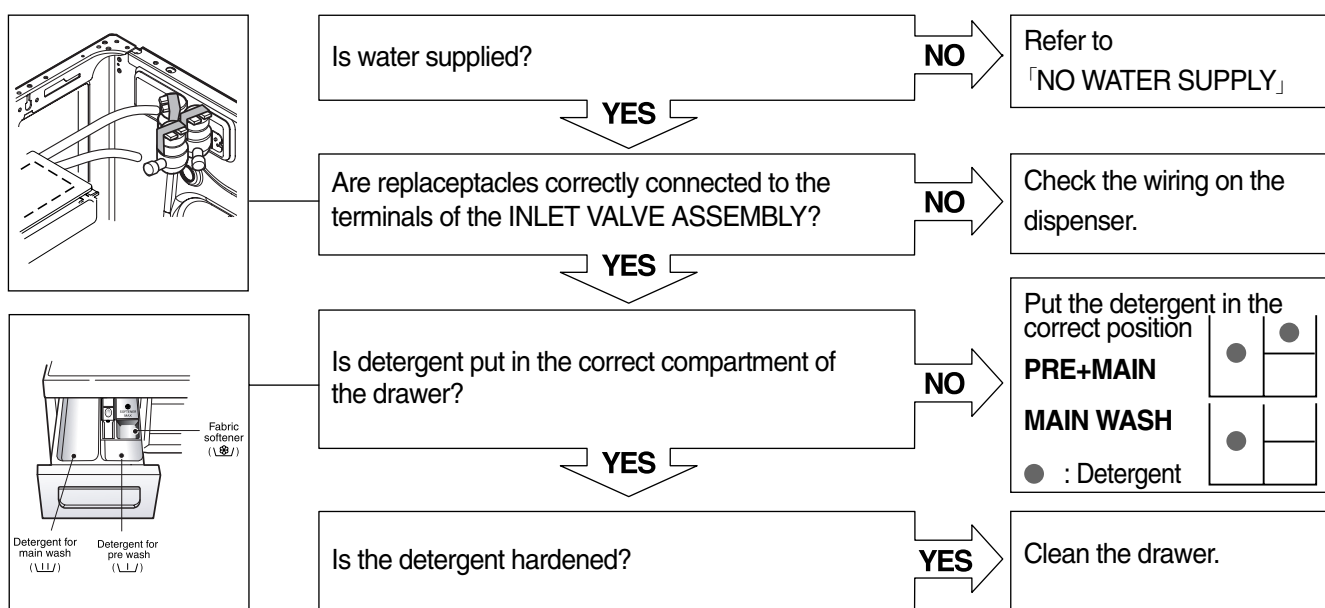

SOFTENER DOES NOT FLOW IN

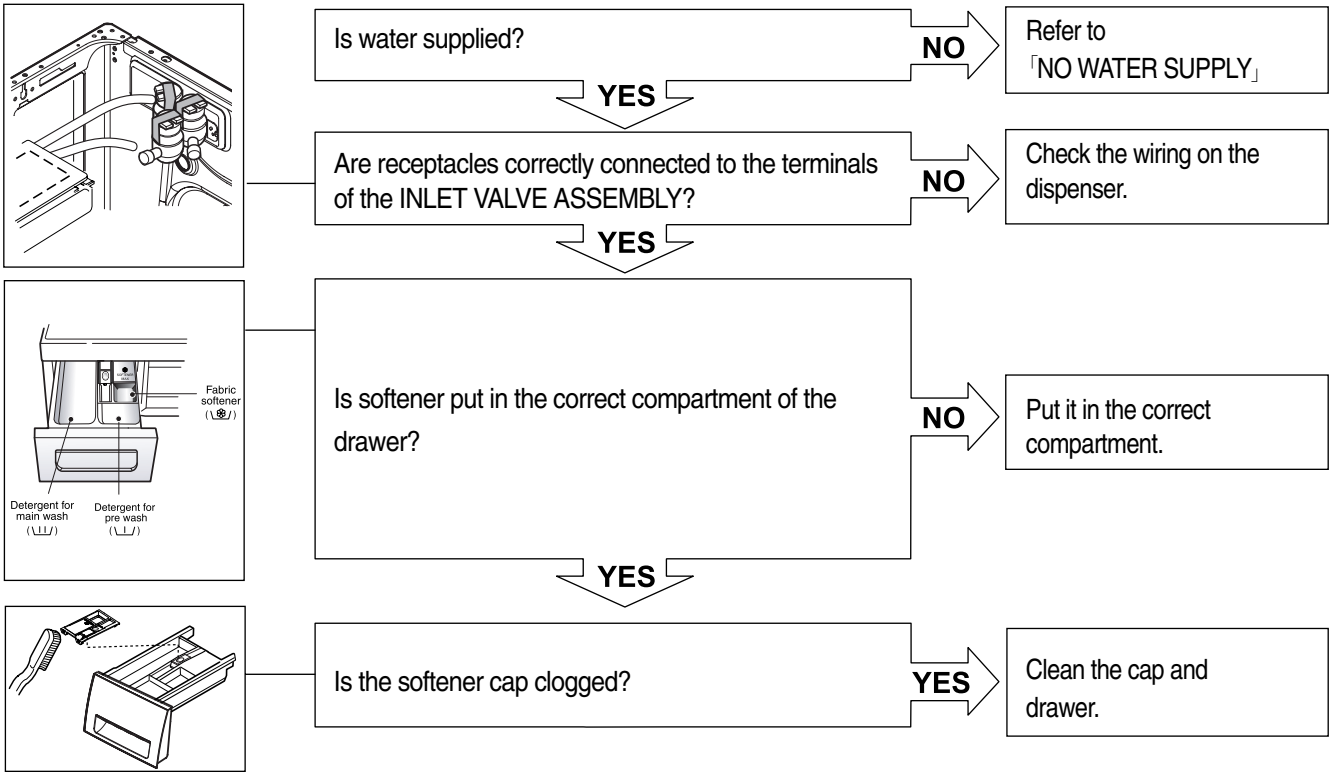

ABNORMAL SOUND

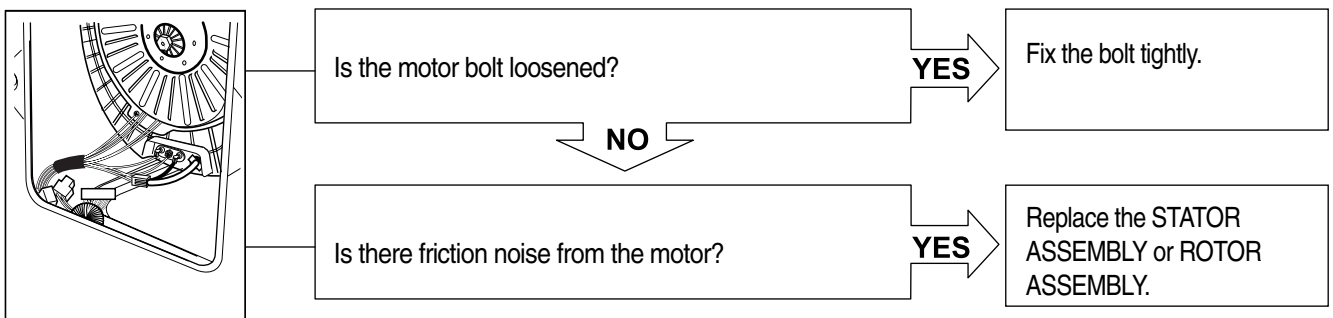

HEATING WITHOUT WATER

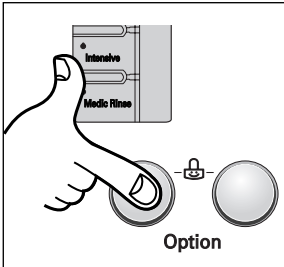

When pressing Intensive and Option(Left) at the same time after draining, is the water level frequency 248 ~ 262 or more?
When pressing Rinse and Temp. buttons at the same time while wash, is the water level frequency between 230 - 243?

NO

Replace the S.PRESSURE SWITCH ASSEMBLY

YES

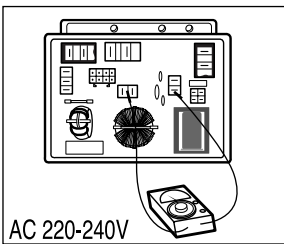

Checking voltage between two pins (Connector RD ① & YL ②) as press the POWER button is the voltage 220-240V~?

YES

Replace the POWER PWB ASSEMBLY

DRAIN MALFUNCTIONING

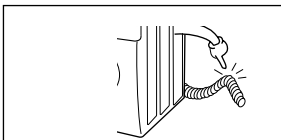

Is the drain hose twisted or frozen?

YES

Repair the DRAIN HOSE ASSEMBLY.

NO

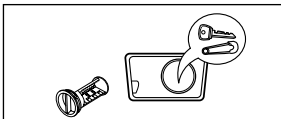

Is the impeller of the drain pump clogged?

YES

Remove foreign material.

NO

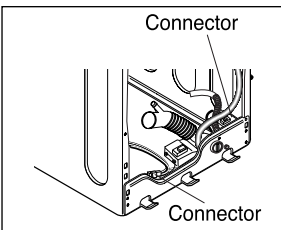

Is the connector disconnected, disassembled?

YES

Reconnect or repair the connector

NO

Is the coil of the drain pump cut-off?
(resistance of coil is 80~150 Ω)

YES

Repair the DRAIN PUMP ASSEMBLY.

NO

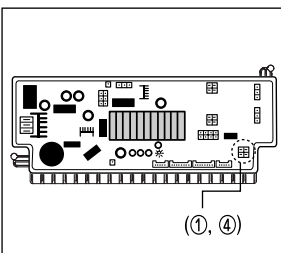

When checking voltage between connectors (①, ④) on spinning, is the voltage 220-240V~ as the figure?

NO

Repair the MAIN PWB ASSEMBLY.

WASH HEATER TROUBLE

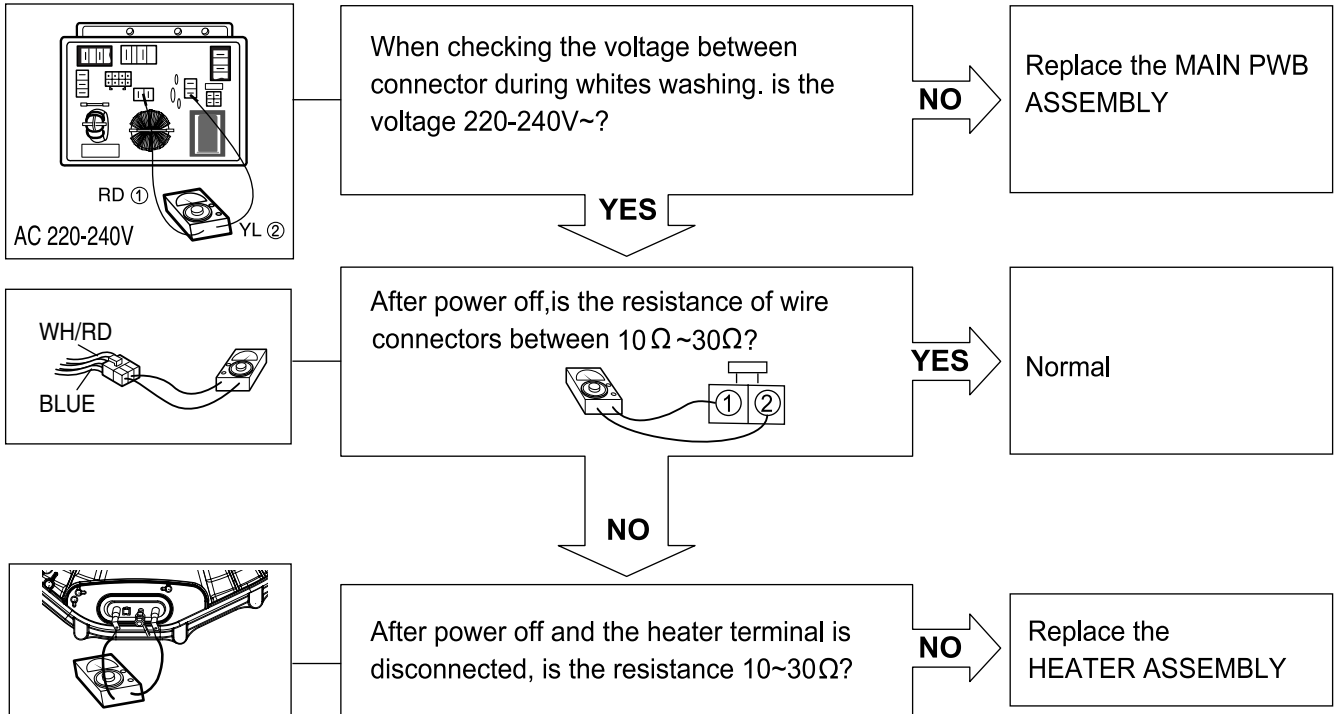

HEATING CONTINUOUSLY ABOVE THE SETTING WATER TEMPERATURE

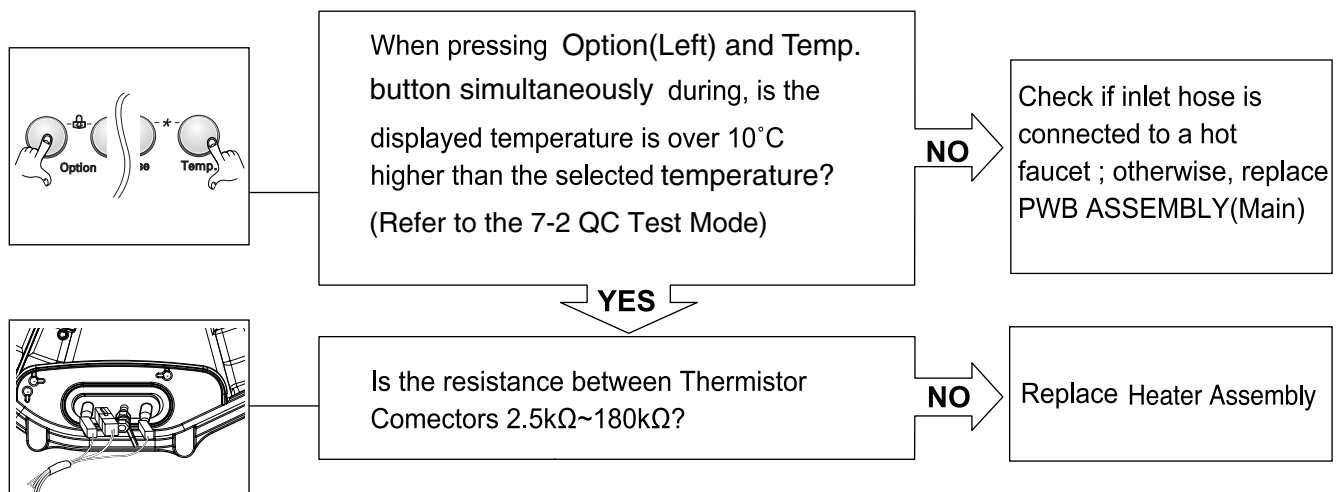

SPIN TROUBLE

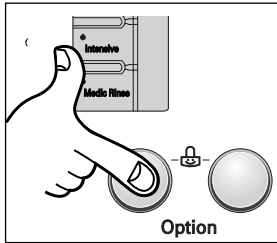

Check on the spinning, is the frequency of the water level 248 or more. The frequency can be checked by pressing the Intensive and Option(Left) buttons at the same time on the program.

NO

Check the S.PRESSURE SWITCH ASSEMBLY or HOSE (Pressure). If the problem is on the S.PRESSURE SWITCH ASSEMBLY or the HOSE, replace the S.PRESSURE SWITCH ASSEMBLY or the HOSE.

YES

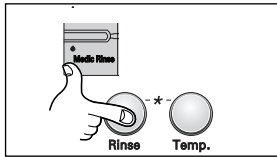

When pressing Rinse, Medic Rinse and POWER buttons at the same time after power off, press the Start/Pause button 1 times, is the drum low speed spin?

YES

Normal

NO

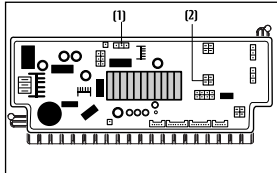

Is it disconnected, or disassembled?
[Red:3pin(1), GY:4pin(2)]

YES

Correct the connector.

NO

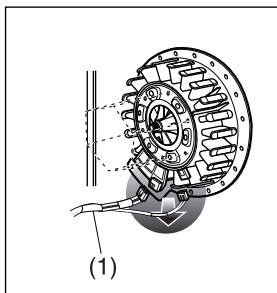

Check the motor connector, is the resistance of the terminal same as the figure?

MOTOR TERMINAL (1)



Resistance of terminal:

①~② / ②~③ / ③~① : About 5Ω~15Ω

NO

Replace the STATOR ASSEMBLY

YES

Replace the MAIN PWB ASSEMBLY

DRAIN TROUBLE

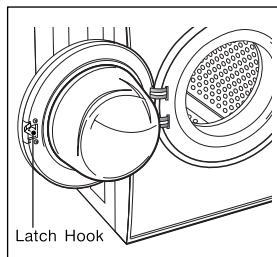

Does the spring of Latch Hook actuate?

NO

Replace Door Assembly.

YES

Is there clicking sound once or twice when the **START/PAUSE** button is pressed to start the cycle?

NO

Check the DOOR SWITCH ASSEMBLY Connector and MAIN PWB ASSEMBLY [Black(1), Brown/Yellow(2)].

YES

Is DOOR SWITCH ASSEMBLY broken?

YES

Replace the DOOR SWITCH ASSEMBLY.

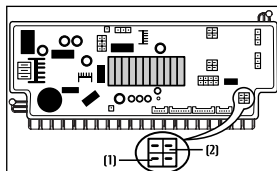

9. DISASSEMBLY INSTRUCTIONS

* Disassemble and repair the parts after pulling out power cord from the outlet.

CONTROL PANEL

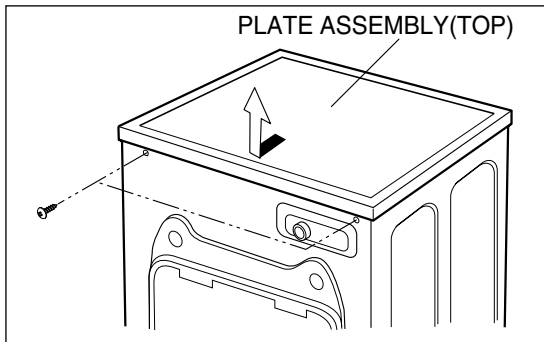

- ① Unscrew the screws on the top plate.
- ② The plate assembly(Top) is pulled back and then upward to arrow direction.
- ③ The cover(Inner) is disassembled.

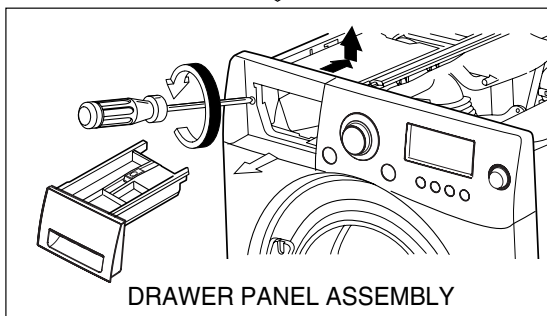

- ① Pull out the drawer and unscrew 2 screws.
- ② Lift the side the Control Panel Assembly and pull it out

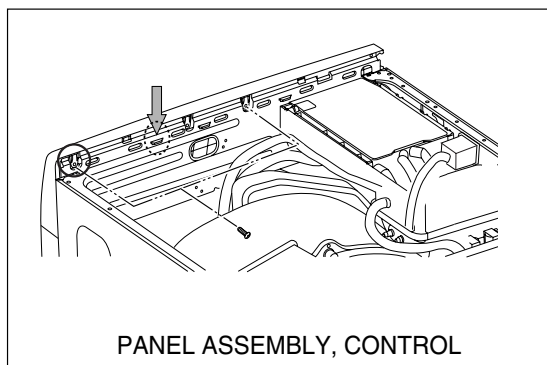

- ① Two screws is unscrewed.
- ② Push out PANEL ASSEMBLY,CONTROL after Push the hook below.

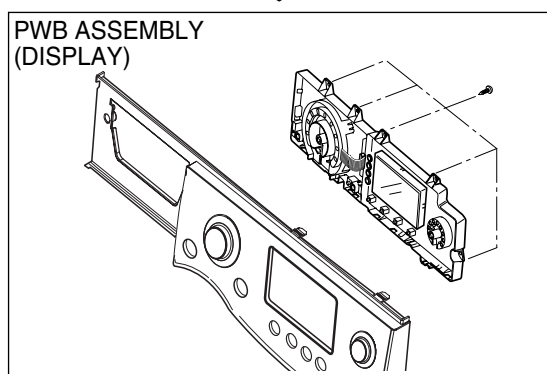

- ① The PWB assembly(Display) is disconnected.
- ② When 7 screws are unscrewed on the PWB insulator and the PWB assembly(Display) is disassembled from the PWB insulator.

PWB ASSEMBLY(MAIN)

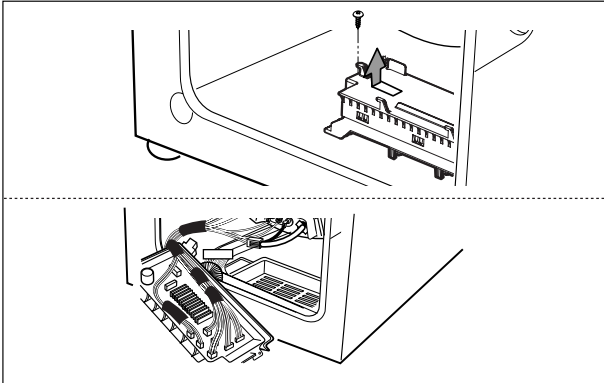

- ① The back cover is removed.
- ② One screw is unscrewed.
- ③ Pull the PWB assembly(Main) to arrow direction
- ④ Two screws is unscrewed.
- ⑤ The cover of PWB assembly(Main) is removed.
- ⑥ Disconnect connector from the wiring.

PWB ASSEMBLY(POWER)

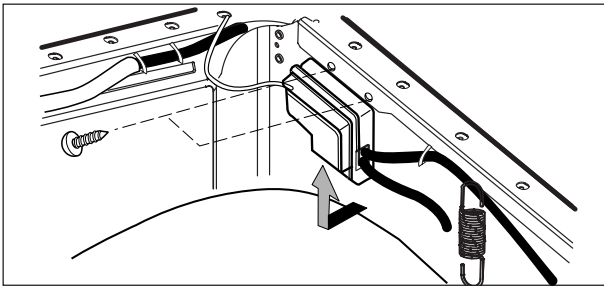

- ① The plate assembly(Top) disassembled.
- ② The cover of PWB assembly(Power) is removed.
(Push the hook bellow.)
- ④ Disconnect connector from the PWB.
- ⑤ Two screw is unscrewed.

DISPENSER ASSEMBLY

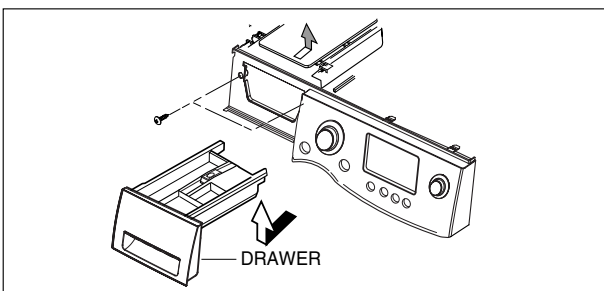

- ① The plate assembly(Top) are disassembled.
- ② Pull the drawer to arrow direction.
- ③ Two screws are unscrewed.

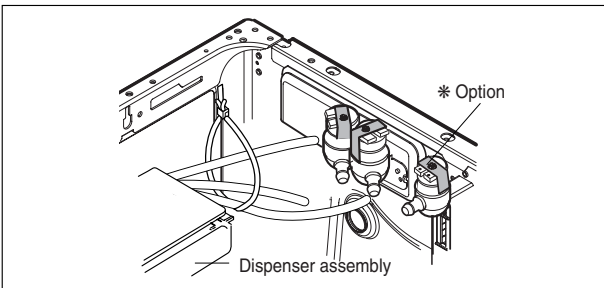

- ① The hose clamps and the hose are disassembled.
- ② The ventilation bellows are disassembled on the tub.

INLET VALVE

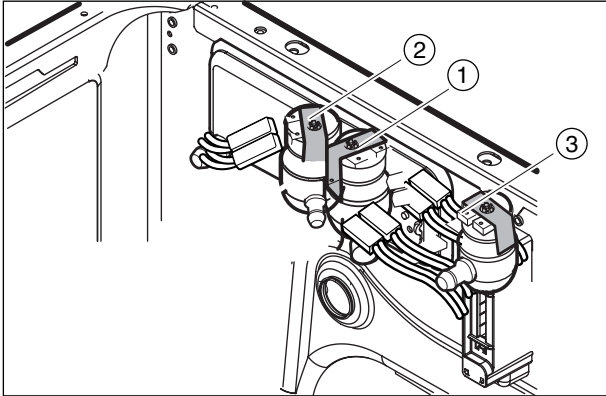

- ① Disconnect the wiring connector.
- ② Remove the valve by two screws of the valve holder.

* When reconnecting the connector

VALVE ① (PRE-WASH)	WHITE/BLACK-BLACK
VALVE ② (NORMAL-WASH)	GRAY/BLACK
VALVE ③ (HOT)	BLACK/WHITE

DOOR

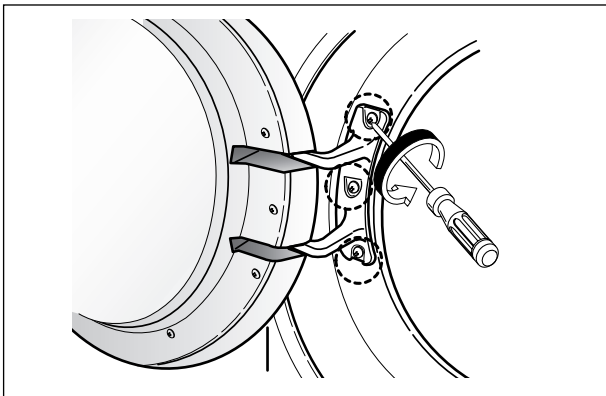

- ① Open the door completely.
- ② Remove the three screws from the hinge.

* When removing the Door Assembly, it is necessary to hold the Bracket that is inner of the Cabinet Cover.

Removing method of remained water

Pull it out from hose.

* First, prepare a bucket to put in the remained water.

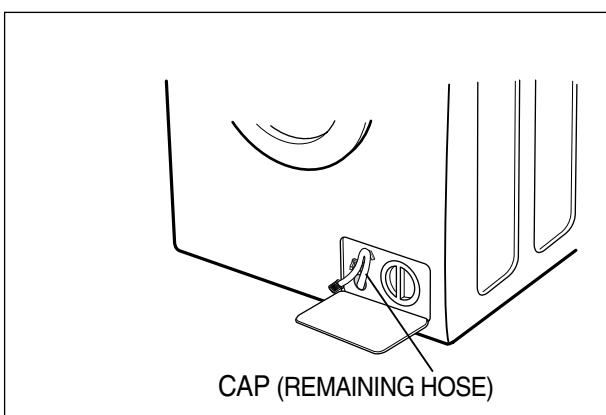

CABINET COVER

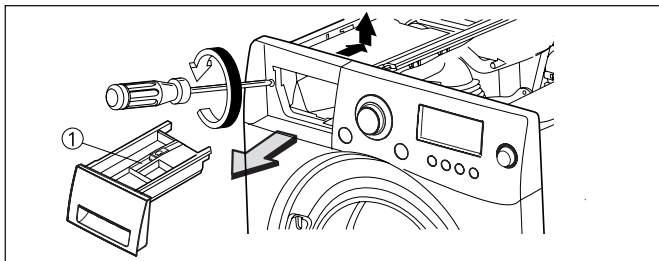

- ① The plate assembly(Top) is disassembled.
- ② Pull out the drawer and unscrew 2 screws.
- ③ Lift the side the Control Panel Assembly and pull it out

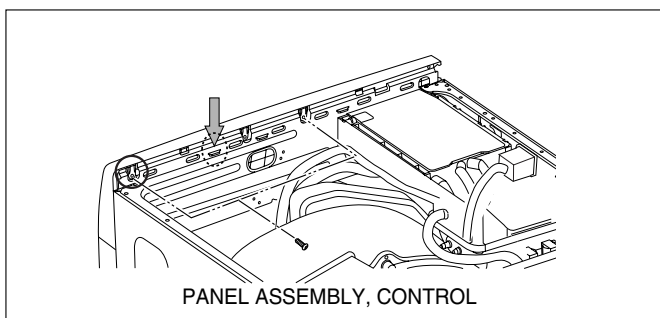

- ① Two screws is unscrewed.
- ② Push out PANEL ASSEMBLY,CONTROL after Push the hook(①, ②) below.

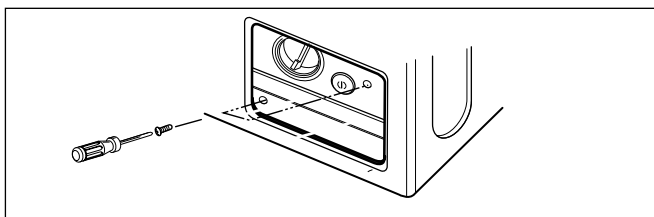

- ③ Unscrew the screws from the lower cover.

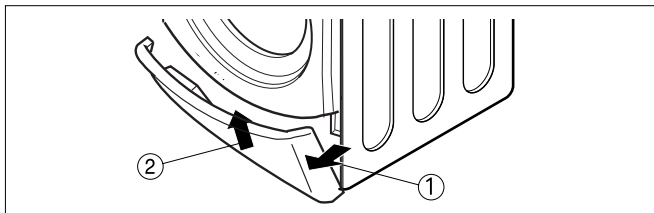

- ② The cabinet cover clamp is removed by special jig for service and the gasket is released.

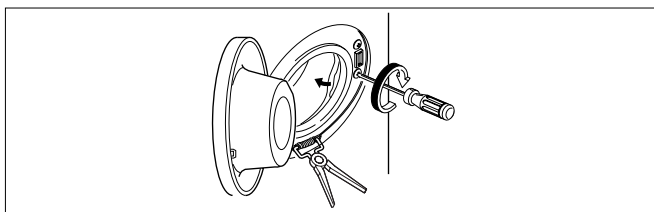

- ③ Two screws are unscrewed.

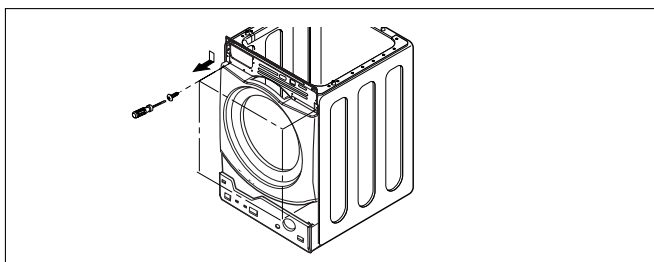

- ④ Unscrew all the screws on the upper and lower sides of the CABINET COVER.

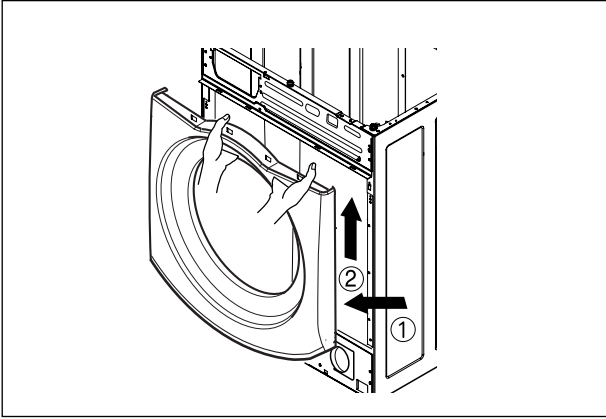

① Lift and separate the cabinet cover.

※ **NOTE:** When assembling the CABINET COVER, connect the Door S/W connector.

SWITCH ASSY, DOOR LOCK

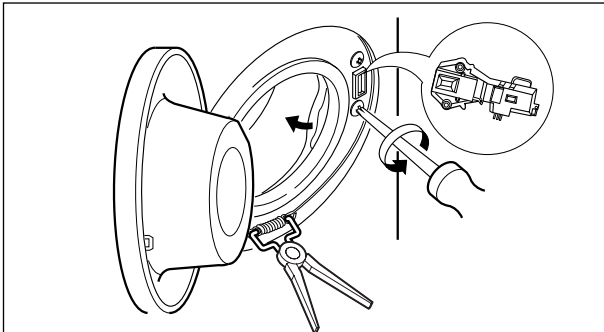

① The cabinet cover clamp is removed and the gasket is released.

② Two screws are unscrewed.

③ The Door Lock S/W is disconnected from the wiring connector and the strap.

ROTOR ASSEMBLY, STATOR ASSEMBLY, FRICTION DAMPER

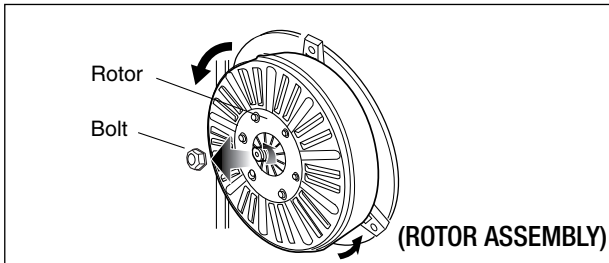

- ① Remove the back cover.
- ② After loosening the bolt, Rotor, pull out the rotor.

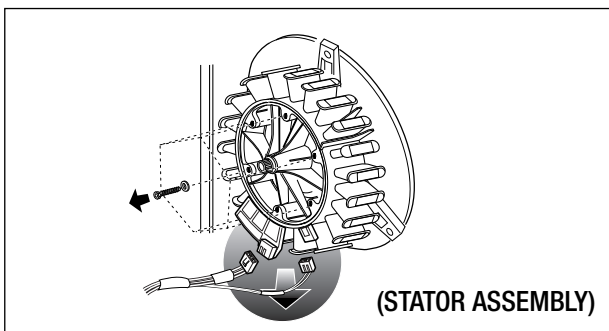

- ① Remove the 6 bolt from the stator.
- ② Disconnect the 2 connectors.

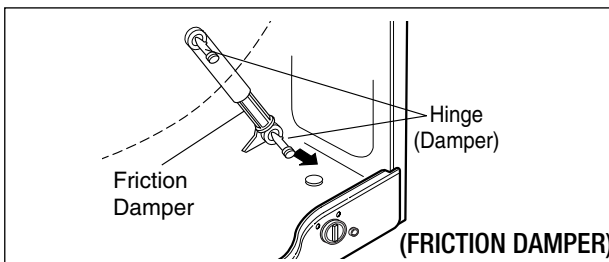

- ① Remove the hinges (Damper) at the Tub.
- ② The Hinge(Damper) at the base is pulled off pressing on the snaps at the sharp end.
- ③ The hinge at the base is pulled off.
(To arrow direction)

PUMP

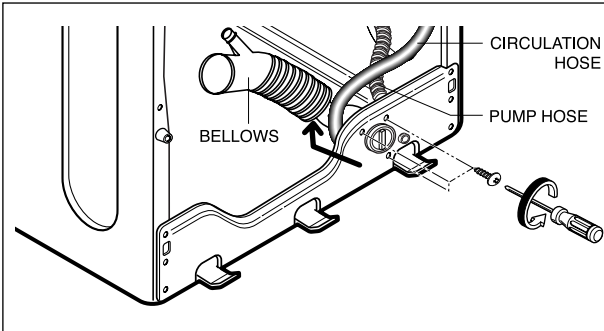

- ① Remove pump outlet hose.
- ② Remove tub pump bellows.
- ③ Remove cap(Remaining Hose).
- ④ Disconnect the wiring.
- ⑤ Three screws are unscrewed from the cabinet.
- ⑥ Remove the pump to arrow direction.

HEATER

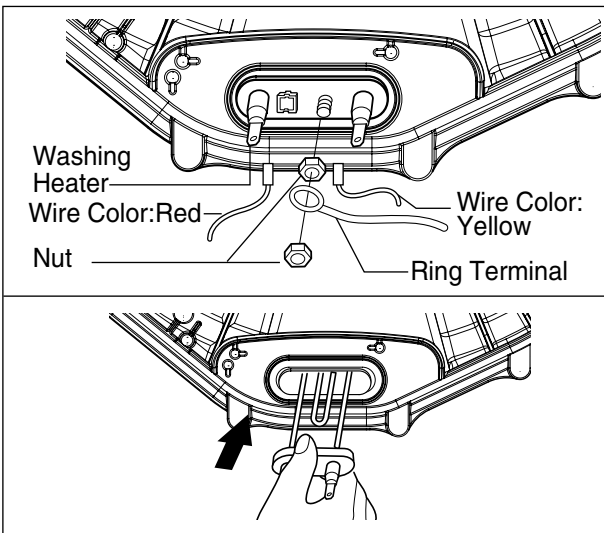

- ① Loosen the nut.
- ② Remove washing heater by pulling out.

CAUTION

When assembling the washing heater, insert the heater to heater clip on the bottom of tub and check the position of wire color.

WHEN FOREIGN OBJECT STUCK BETWEEN DRUM AND TUB

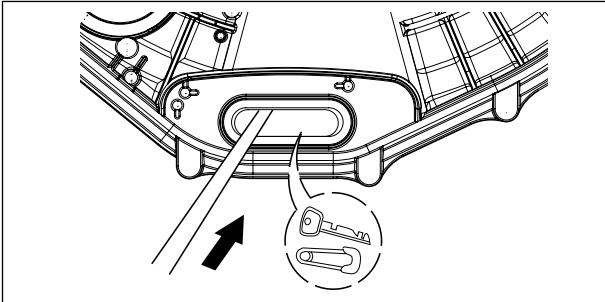

- ① Remove washing heater.
- ② Remove the foreign object(wire,coin,etc) by inserting long bar in the hole.

SWITCH ASSEMBLY, SAFETY

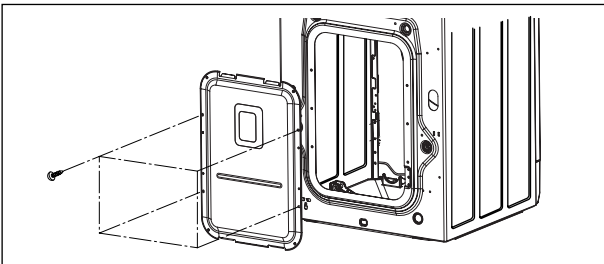

Unscrew 4 screws from the back cover.

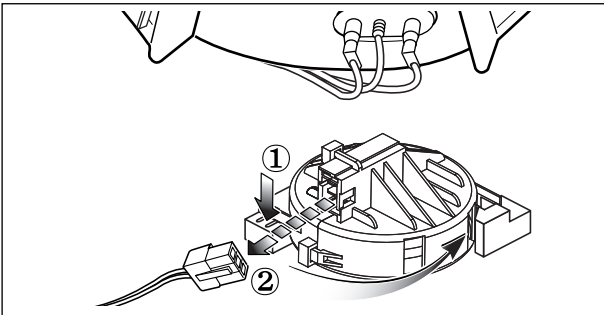

Disconnect the wiring connector.
First, Press hook and turn the safety switch
assembly switch assembly safety.

10. EXPLODED VIEW AND PART LIST

10-1. THE PART LIST OF CABINET ASSEMBLY

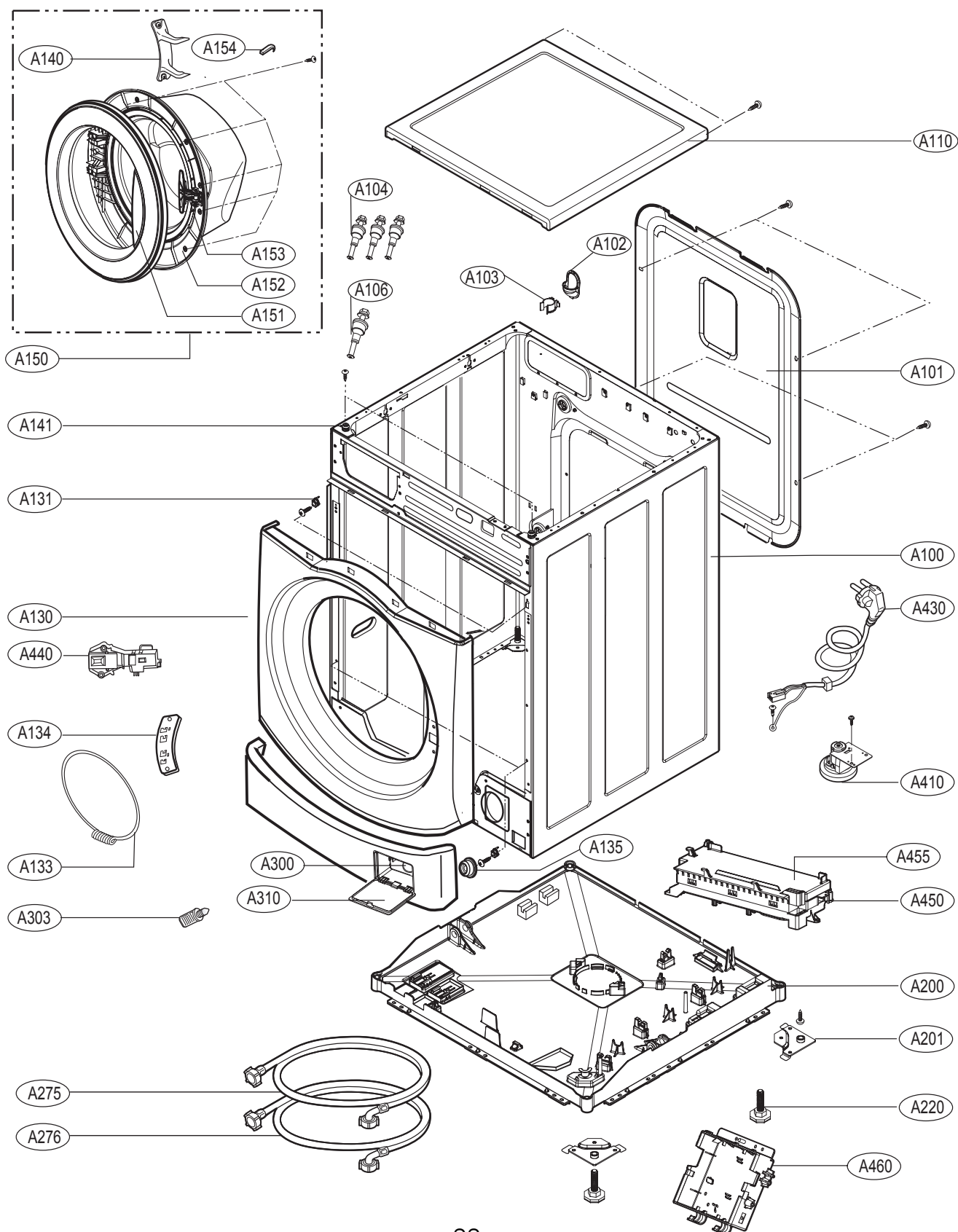

10-2 THE EXPLODED VIEW OF CONTROL PANEL & DISPENSER ASSEMBLY

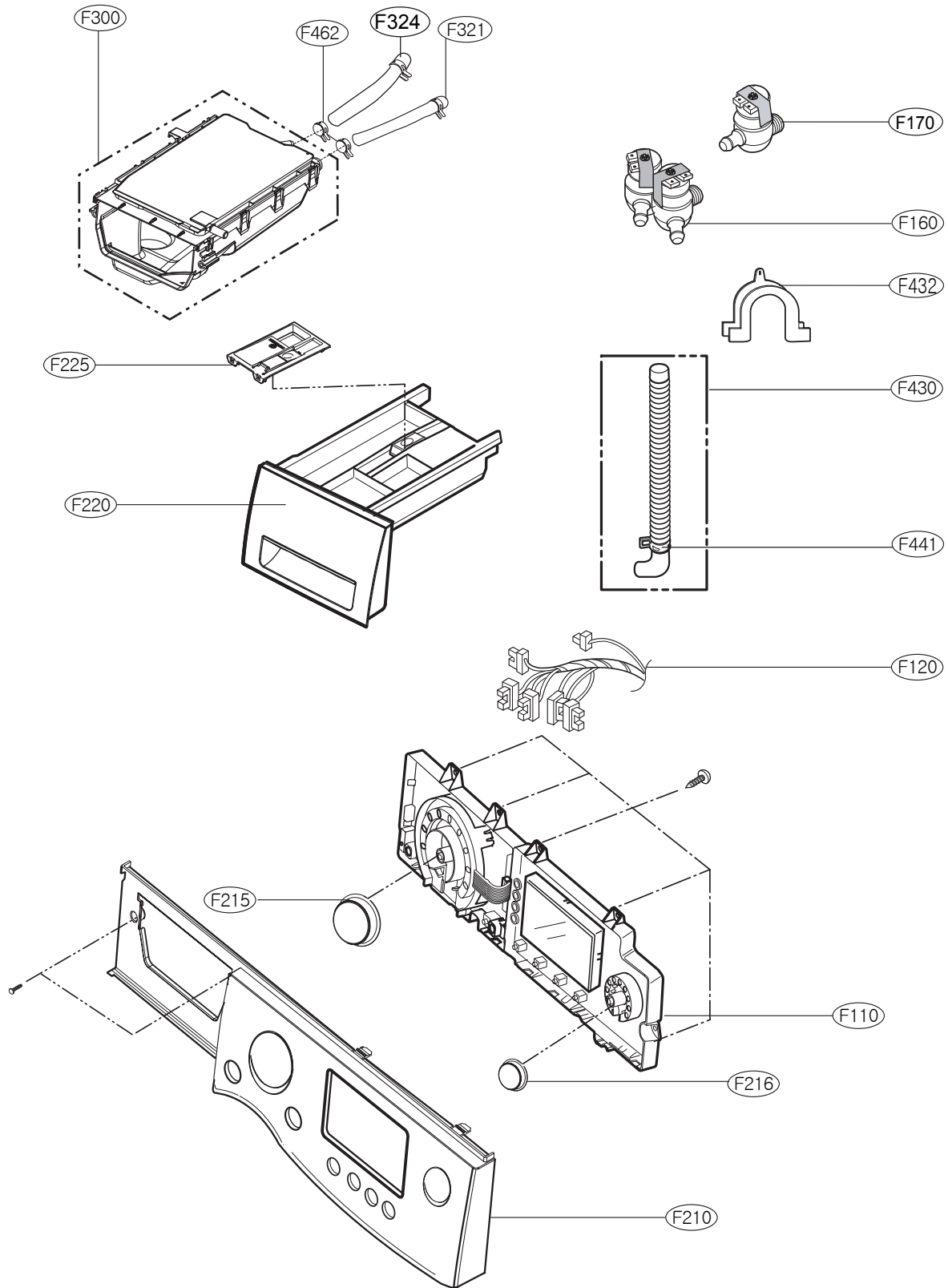

10-3 THE EXPLODED VIEW OF DRUM & TUB ASSEMBLY

