

This Owner's Manual is provided and hosted by [Appliance Factory Parts](#).



# LG WM3455HW Owner's Manual

[Shop genuine replacement parts for LG WM3455HW](#)



[Find Your LG Washer Parts - Select From 393 Models](#)

----- Manual continues below -----



website : <http://biz.lgservice.com>  
e-mail : <http://LGEservice.com/techsup.html>

# WASHING MACHINE SERVICE MANUAL

## CAUTION

READ THIS MANUAL CAREFULLY TO DIAGNOSE TROUBLES  
CORRECTLY BEFORE OFFERING SERVICE.

MODEL : WD-1409RD(1~9)/WDP1103RD(1~9)/WM3455



P/No.: MFL30574764

---

# CONTENTS

1. SPECIFICATIONS .....	3
2. FEATURES & TECHNICAL EXPLANATION .....	4
3. PARTS IDENTIFICATION .....	6
4. INSTALLATION .....	7
5. OPERATION .....	12
6. WIRING DIAGRAM / PCB LAYOUT / PROGRAM CHART .....	14
7. TROUBLESHOOTING .....	18
7-1. BEFORE PREFORMING SERVICE .....	18
7-2. LOAD TEST MODE .....	18
7-3. HOW TO KNOW THE WATER LEVEL FREQUENCY .....	19
7-4. HOW TO KNOW TO TEMPERATURE OF EACH THERMISTOR AT OPERATING CONDITION ..	19
7-5. ERROR DISPLAY .....	20
7-6. TROUBLESHOOTING WITH ERROR .....	21
• IE (Water Inlet Error) .....	21
• UE (Unbalanced Error) .....	22
• OE (Water Outlet Error) .....	23
• FE (Flow over Error) .....	25
• PE (Pressure Sensor S/W Error) .....	26
• DE (Door open Error) .....	27
• tE (Thermistor (Heating) Error) .....	28
• LE (Motor Lock Error) .....	29
• DHE (Dry Heater Error) .....	31
• Dry Heater Trouble .....	32
• Dry Fan Motor Trouble .....	33
8. TROUBLESHOOTING ELSE .....	34
• No Power .....	34
• Vibration & Noise in spin .....	35
• Detergent & Softener does not flow in .....	36
• Water Leak .....	37
9. DISASSEMBLY INSTRUCTIONS .....	39
10. EXPLODED VIEW .....	47

# 1. SPECIFICATION

ITEM		WD-1409RD(1~9)/WDP1103RD(1~9)
POWER SUPPLY		127V~, 60Hz
PRODUCT WEIGHT		72kg
ELECTRICITY CONSUMPTION	WASHING	140W
	SPIN	440W
	DRAIN MOTOR	30W
	STEAM HEATER	1100W
	WASH HEATER	2000W
	DRY HEATER	1500W
REVOLUTION SPEED	WASH	50rpm
	SPIN	No Spin/400/800/1000/1400
OPERATION WATER PRESSURE		1.0-8bar (100-800kPa)
CONTROL TYPE		Electronic
WASH & DRY CAPACITY		Refer to the Rating Label
DIMENSION		600mm(W)x640mm(D)x850mm(H)
WASH PROGRAM		Cotton, Cotton Quick, Synthetic, Delicate, Quick30, Duvet, Baby Care
RINSE		Rinse+Spin, Rinse <sup>+</sup> , Normal+H
DOOR SWITCH TYPE		Bi-Metal type
WATER LEVEL		10 steps (by sensor)
RESERVATION		From 3 hours to 19 hours
SENSING OF THE LAUNDRY AMOUNT		Adapted
FUZZY LOGIC		Adapted
DISPLAY OF THE REMAINING TIME		Adapted
ERROR DIAGNOSIS		10 items
POWER AUTO OFF		Adapted
CHILD LOCK		Adapted
AUTO RESTART		Adapted
TIME SAVE		Adapted

# 2. FEATURES & TECHNICAL EXPLANATION

---

## 2-1. FEATURES



- **Direct Drive System**

The advanced Brushless DC motor directly drives the drum without belt and pulley.



- **Water Circulation**

Spray detergent solution and water over the load over continu.

Clothes are soaked more quickly and thoroughly during wash cycle.

The detergent suds can be removed more easily by the water shower during rinse cycle.

The water circulation system uses both water and detergent more efficiently.



- **Built-in Heater**

Internal heater automatically heats the water to the best temperature on selected cycles.



- **Child Lock**

The Child lock prevents children from pressing any button to change the settings during operation.



- **More economical by Intelligent Wash System**

Intelligent Wash System detects the amount of load and water temperature, and then determines the optimum water level and washing time to minimize energy and water consumption.



- **Low noise speed control system**

By sensing the amount of load and balance, it evenly distributes load to minimize the spinning noise level.



- **Automatic Wash Load Detection**

Automatically detects the load and optimizes the washing time.

---

## 2-2. DETERMINE WASHING TIME BY FUZZY LOGIC

To get the best washing performance optimal time is determined by sensing of water temperature, selected washing temperature and laundry amount.

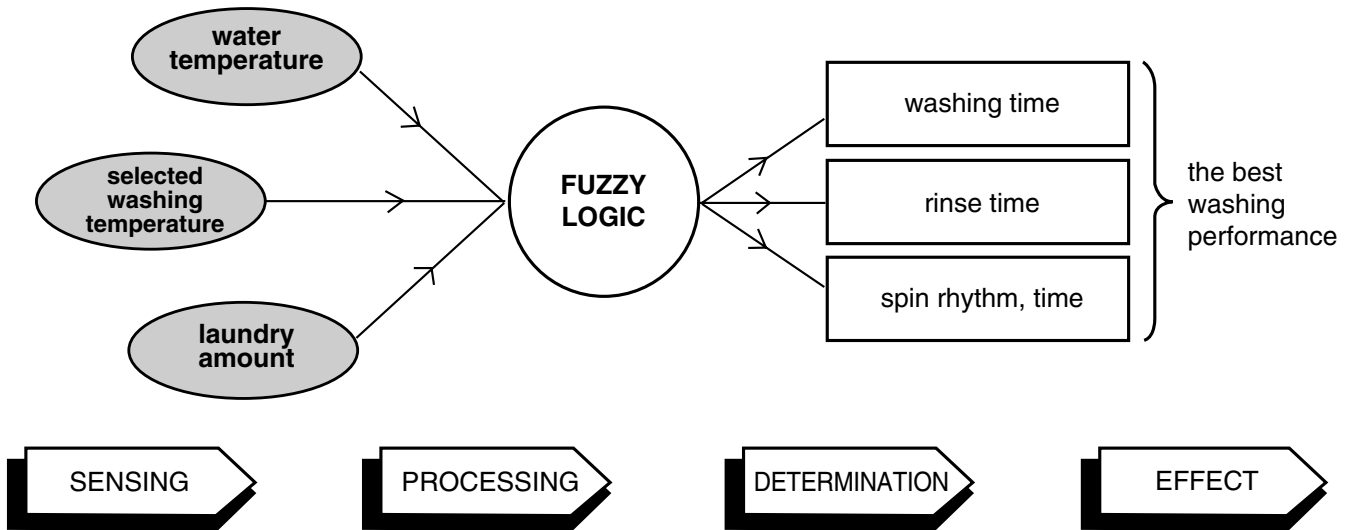

## 2-3. WATER LEVEL CONTROL

- This model adopts a pressure sensor which can sense the water level in the tub.
- Water supply is stopped when the water level to the preset level, then washing program proceeds.
- Spinning does not proceed until the water in the tub reduces to a certain level.

## 2-4. THE DOOR CAN NOT BE OPENED

- While program is operating.
- While **Door Lock** light turns on.

# 3. PARTS IDENTIFICATION

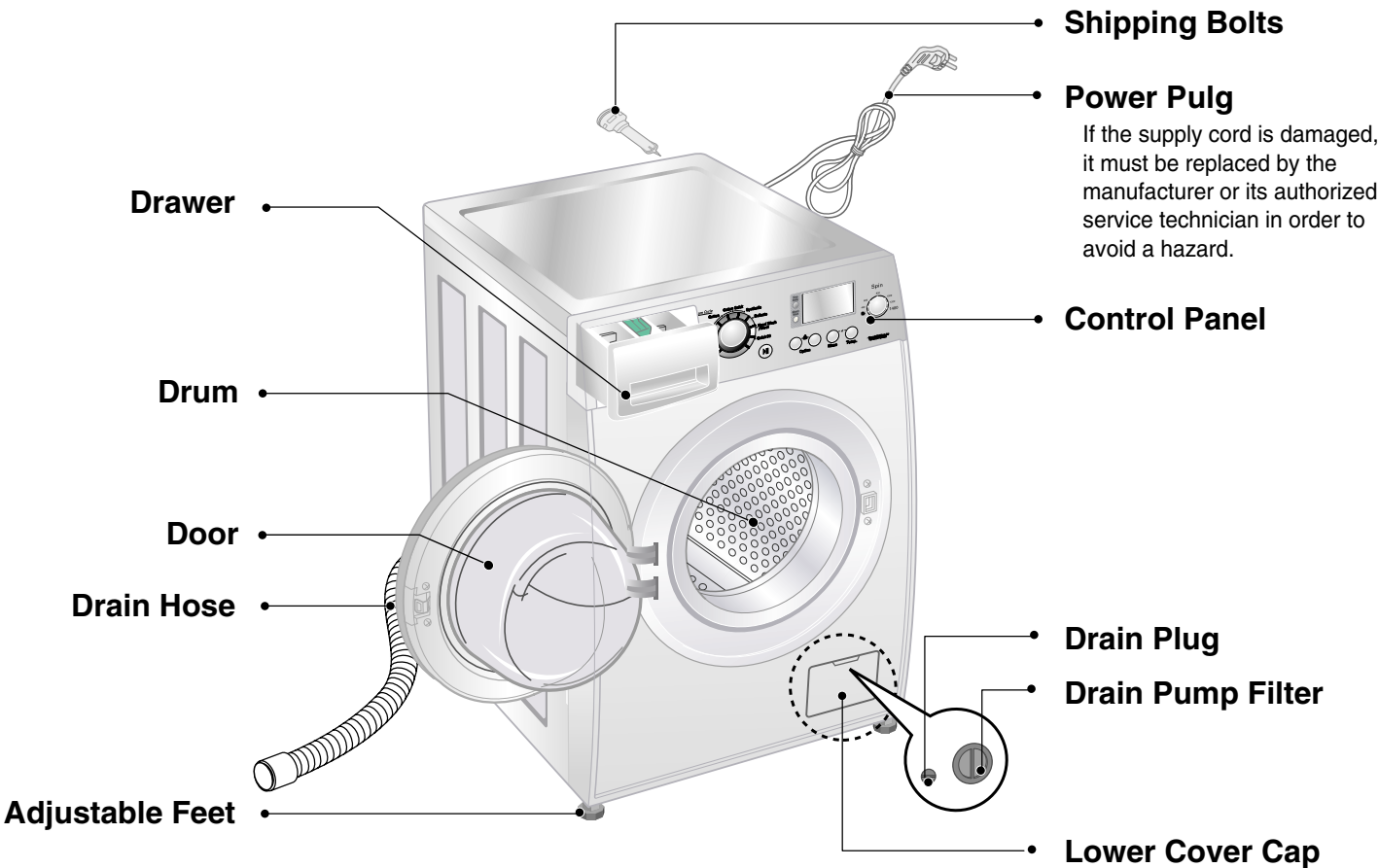

## ■ ACCESSORIES



# 4. INSTALLATION

## ■ INSTALLATION

The appliance should be installed as follows.

### 1 Check the conditions of installation area.

#### 1. Check level ground.

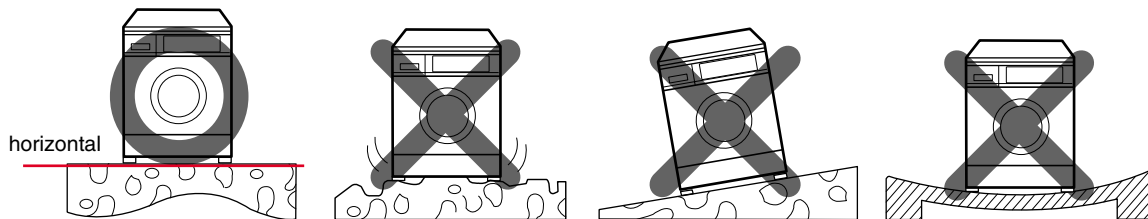

On raised foundations or upper level homes, the **vibrations** can be caused by the type of flooring. It may be **necessary to move the machine** to a different area in the home or have the floor reinforced to properly support the operation of the unit.

#### 2. Check humidity or any foreign objects under the feet.

Clean the floor, and there should not be any foreign objects under the feet. If the unit has foreign objects underneath the feet, this will prevent the unit from being leveled properly and will cause **vibrations** and **slipping**.

**Remove any foreign objects**, if any from underneath the machine and level unit properly.

See below for examples of foreign objects.



**Purchased stopper**



**Capet**



**Paper**



**Laminated paper**

### 2 Open the box and check appliance condition.

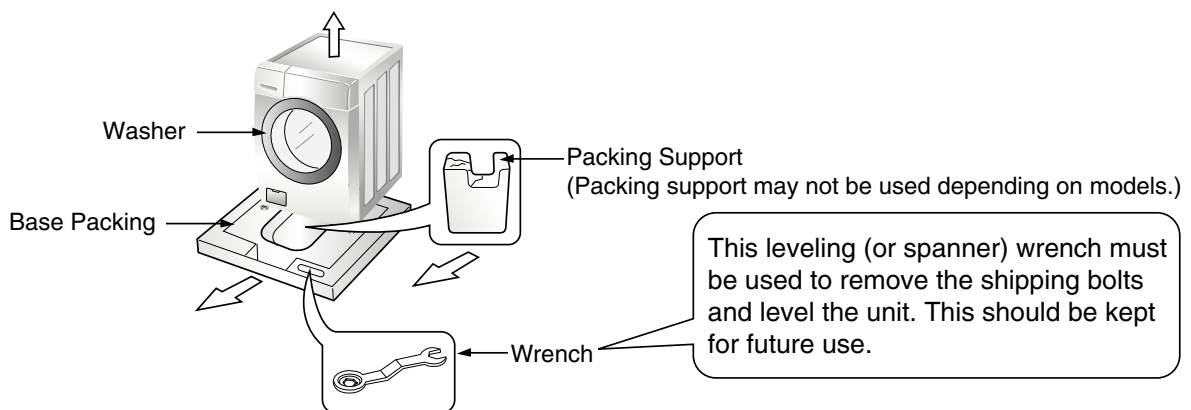

### 3 Use spanner to remove transit bolts.



X 4 EA

Transit bolts

※ Without removal of transit bolts  
▶ **Spin noise** and **shaking**.

### 4 Confirm the distance between the appliance and the wall.

More than 2cm

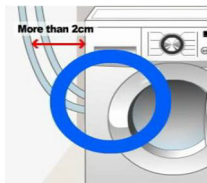

※ If the distance is less than 2cm,  
the water supply hose will  
**kink** or **fold**.



### 5 The tap connection and hose connection must be parallel.

#### 1. Normal Tap without thread & screw type inlet hose.

1. Unscrew the fixing screw to attach the tap.

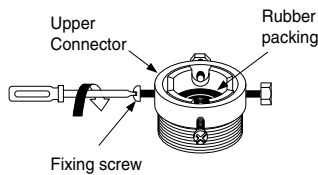

2. Push the connector up till the rubber packing is in tight contact with the tap. Then tighten the 4 screws.

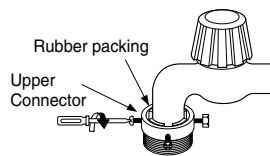

3. Push the water supply hose vertically upwards so that the rubber packing within in the hose can adhere completely to the tap and then tighten it by screwing it to the right.

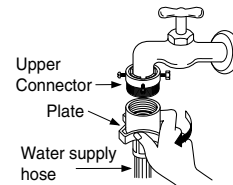

#### 2. Normal Tap without thread & one touch type inlet hose (Single inlet models)

1. Untighten the upper connector screw.

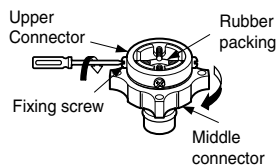

• In case the diameter of the tap is large remove the guide plate.

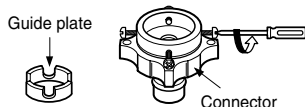

2. Push the upper connector up till the rubber packing is in tight contact with the tap. Then tighten the 4 screws.

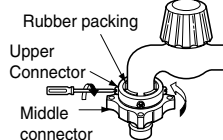

• Turn the middle connector not to have water leaked.  
• Make sure that the rubber seal is inside the hose connector.

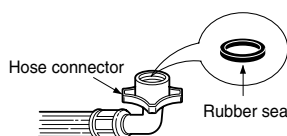

3. Connect the water supply hose to the middle connector, pushing the plate down.

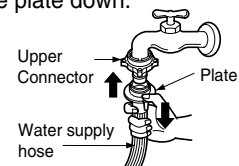

• To separate the water supply hose from the middle connector shut off the tap. Then pull the inlet hose down, pushing the plate down.

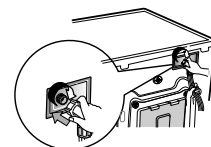

• Make sure that there are no kinks in the hose and that it is not crushed.

## 6 Connect Drain Hose.

If the drain hose is not installed properly, the unit will not drain properly.

This allows water to back flow into the unit which can cause odors.

Refer to Owner Manual for proper drain hose installation.

The odor could also be coming from the home's drain to which the drain hose is attached.

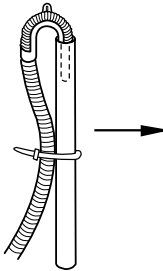
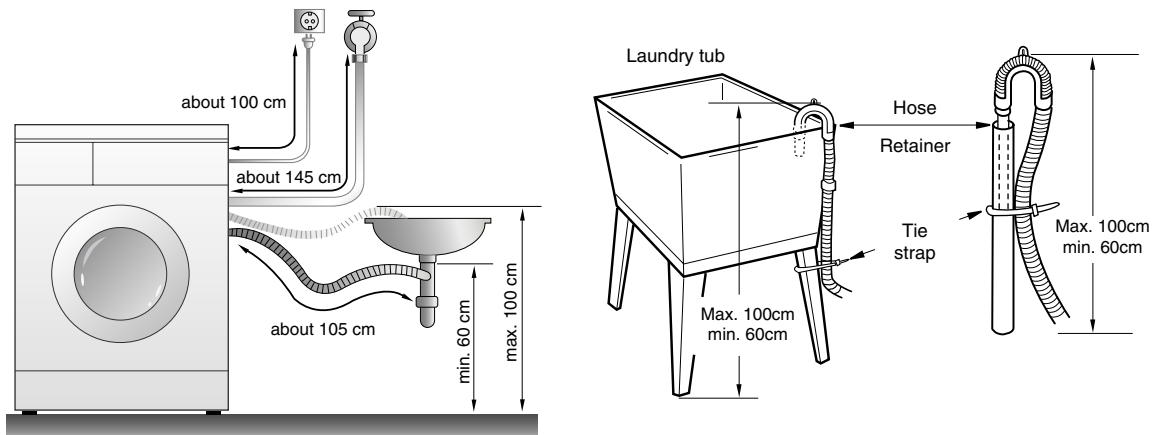

In this type of drain hose installation, the odor could be coming from the standpipe.

This odor can come up the drain hose and into the unit.

Pour a cup or two of bleach or vinegar down the home drain

and let it sit for 24 hours before running another cycle.

This will help eliminate odor from the home drain.

If a cycle is started too soon after doing this, it will not help the issue.

## 7 Connect power plug.

Connect the power plug to the wall outlet.

Avoid connecting several electric devices, it may be the cause of a fire.

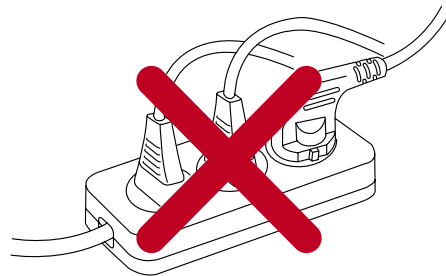
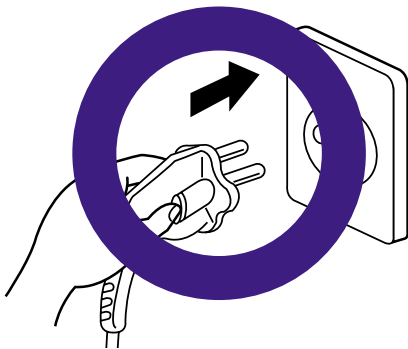

## 8 Check the horizontality with a level (Gage).

### 1 Step

If washing machine legs are loose or not screwed, then **screw up** with the spanner wrench. Using the level, level the washing machine from front to back and side to side.

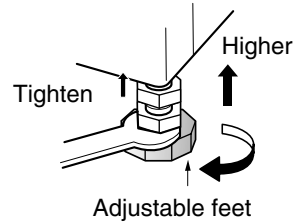
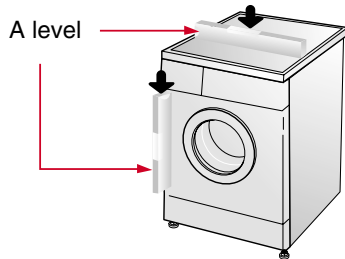

### 2 Step

Using the spanner wrench to adjust leg for **horizontality** and try for **Diagonal test**.

#### Diagonal test



#### ※ How to perform a diagonal test:

Place your right hand on the back, right corner and your left hand on the front, left corner of the unit, then attempt to rock the unit from corner to corner. Then, move your right hand to the front, right side and your left hand to the back, left corner and attempt to rock the unit from corner to corner. If the unit is level, it will not rock. However, if the unit is not level, it will rock. If the unit rocks, it will be necessary to adjust the leveling feet of the unit. Adjust the foot under the hand that is on the front of the machine.

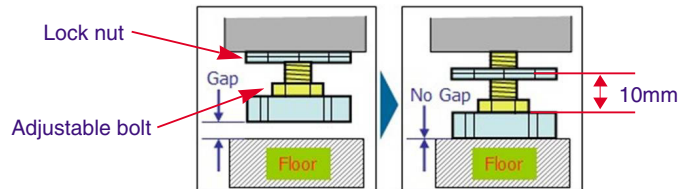
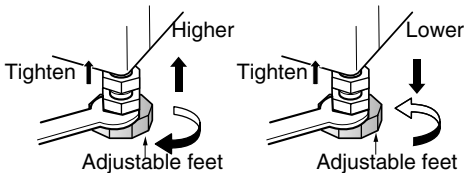

Lower the foot until there is no gap between floor and foot.

And only use **adjustment rubber** when difference at the leg adjustment is more than **10mm**.

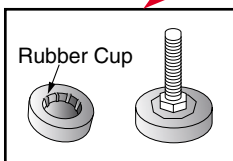

### 3 Step

Perform a Rinse and Spin with some clothing in the machine.

To do this, put 2~3kg of clothing in the unit, power on the unit, press the Rinse and Spin button, and then start. When the unit reaches the spin cycle, watch for vibrations.

If the unit is vibrating, make small adjustments to the leg until they subside. (Try 2Step again)

### 4 Step

**Tighten** the lock nut against the base of the machine to **lock** the **position leg**.

Tighten the lock nut

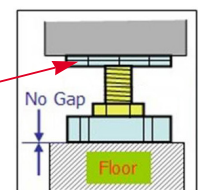

## 9 Test operation

### 1 Preparation for washing.

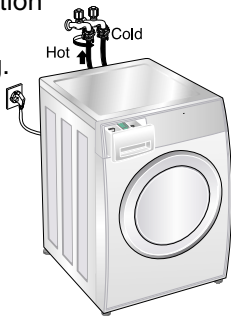

- Connect the power plug to the outlet.
- Connect the inlet hose.

### 2 Press the power button.



### 3 Press the START/PAUSE button.

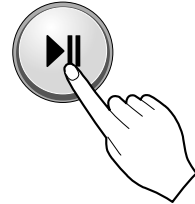

- In case of Coloreds® program.

### 6 Check the water heating.



- Press the Option(Left) + Temp. button simultaneously and the present temperature will be displayed. Page 13

### 5 Check automatic reverse turn.



- Check if the drum rotates clockwise and counterclockwise.

### 4 Check the water supply.

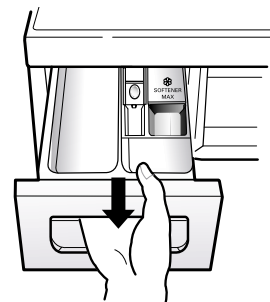

- Check if water is supplied through the detergent dispenser.

### 7 Check drain and spin.

- Turn off Wash and Rinse after pressing the Start/Pause button and start the machine again.
- Check drain and spin.

### 8 Power off and open the door.



- Power off and then power on.
- Check if the door can be opened after 3 minutes.

### 9 Water removal.

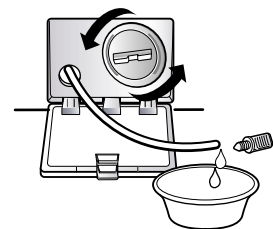

- If SVC is needed during check, remove the remaining water by pulling out the hose cap.

# 5. OPERATION

## Cycle Selector

- Rotate the **Cycle selector knob** to select the cycle designed for different types of fabric and soil levels.

## Additional programs

- Time Delay : Allows the start of any cycle to be delayed for 3~19 hours.
- Favorite : Favorite program allows you to store a customized operation for next use.
- Intensive : If the laundry is heavily soiled “Intensive” option is effective.
- Medic Rinse : For high effectiveness or more purity in rinse operation you can choose Medic Rinse option. Medic Rinse is default in Baby Care program.

## Power

- Use this button to turn the power **On/Off**.

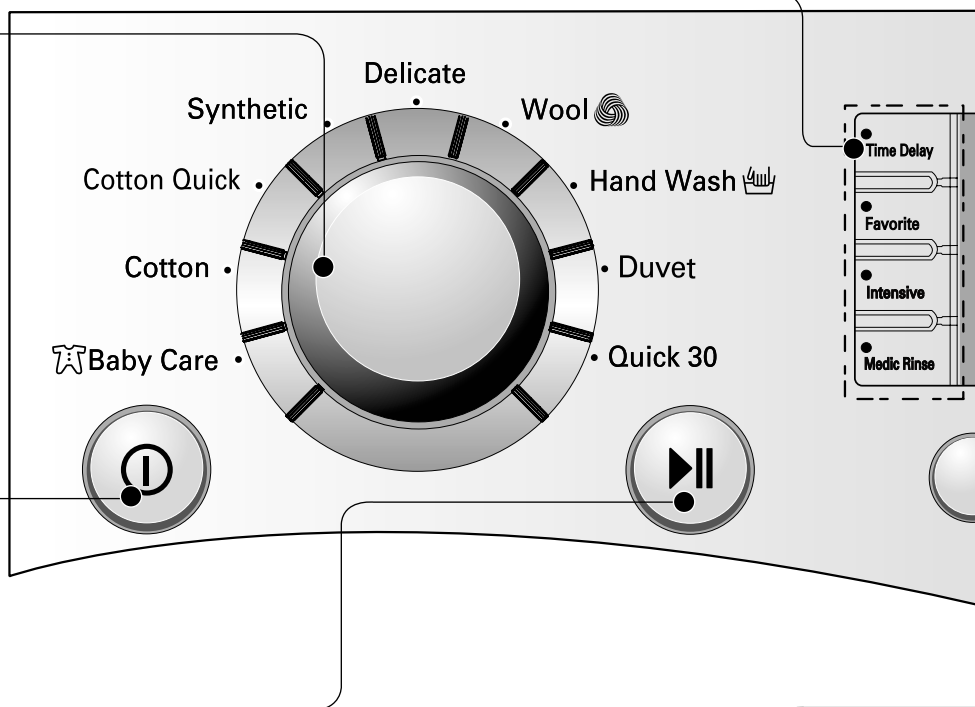

## Start/Pause

- Use this button to Start/ Stop the washer.

## Option Button

- Pre Wash : If the laundry is heavily soiled, “Pre Wash” Cotton is recommended.
- Rinse+ : Used to additional rinse, which may assist in removing traces of detergent residue.
- Normal+Hold : If you desire to leave fabrics in the machine without spinning after rinse to prevent wrinkling, you may select Normal+Hold by pressing the Option button.
- Rinse + Spin : Use this option to rinse and then spin.

### Dry Selector knob

- Dry programs selected by rotating dry knob.
- [Lower Temp. - Iron Dry - Cupboard Dry - Eco Dry - Time(30,60,120)] can be selected.

### Tub Clean

- Tub Clean course can be set by pressing and holding Intensive and Pre Wash button simultaneously.
- Tub Clean is special cycle to clean the inside of the washer.

### Spin,Temp. Button

- To change the spin speed, Press the Spin button to cycle through available options.
- Select a water temperature based on the type of load you are washing.

### Beep on/off

- The Beep on/off function can be set by pressing and holding the Option and Spin button simultaneously.



### Child Lock

- Use this option to prevent unwanted use of the washer. Press and hold 2 Option buttons for 3 seconds to lock/unlock control.
- When Child lock is set, CHILD LOCK lights and all buttons are disabled except the Power (Ⓟ) button. You can lock the washer while it is operating.

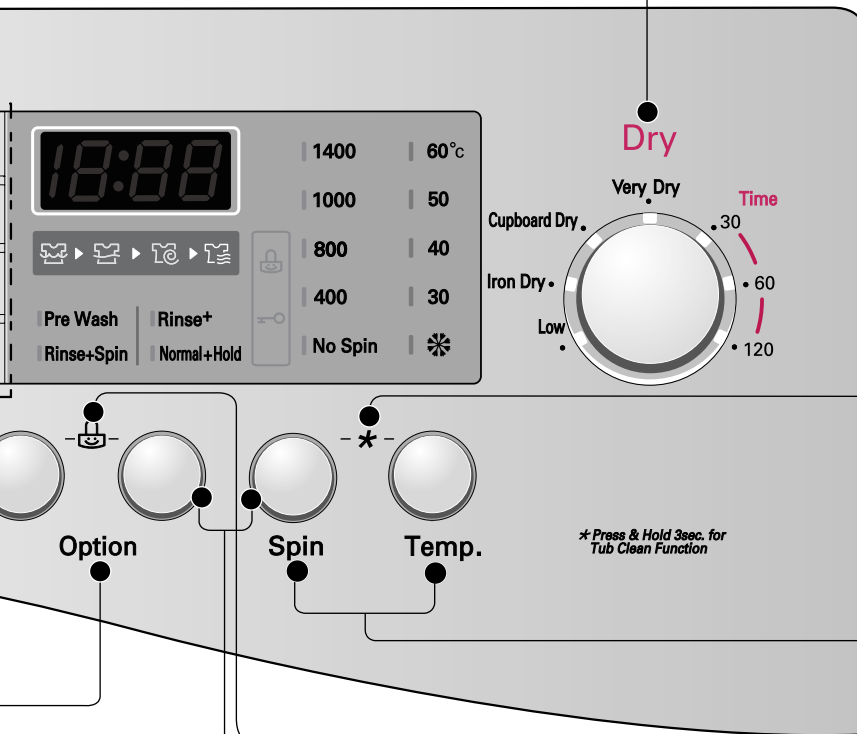

# 6. WIRING DIAGRAM / PCB LAYOUT / PROGRAM CHART

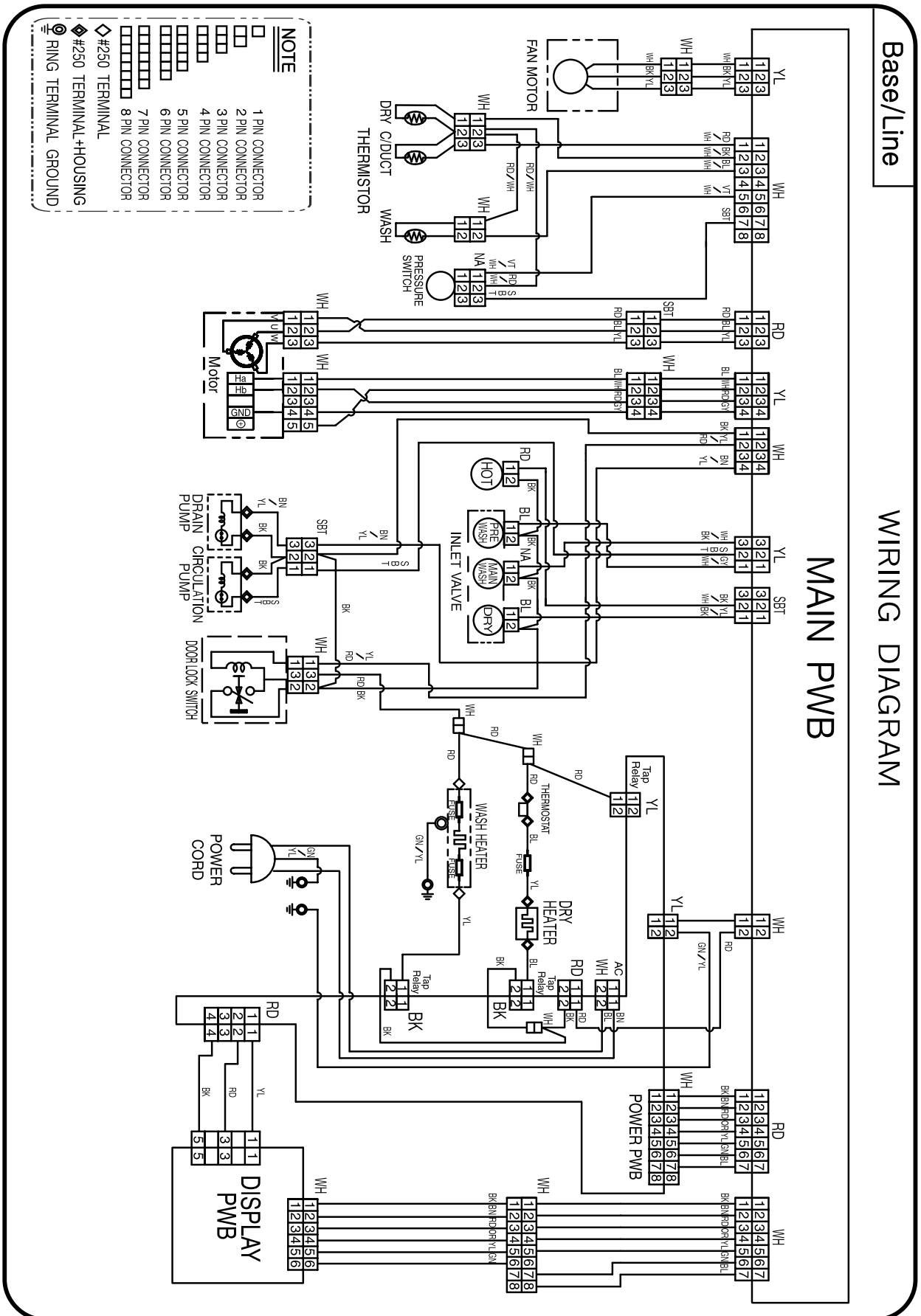

**NOTE**

- 1 PIN CONNECTOR
- 2 PIN CONNECTOR
- 3 PIN CONNECTOR
- 4 PIN CONNECTOR
- 5 PIN CONNECTOR
- 6 PIN CONNECTOR
- 7 PIN CONNECTOR
- 8 PIN CONNECTOR
- ◇ #250 TERMINAL
- ◇ #250 TERMINAL+HOUSING
- ⊕ RING TERMINAL GROUND

## ■ PCB Layout (Main)

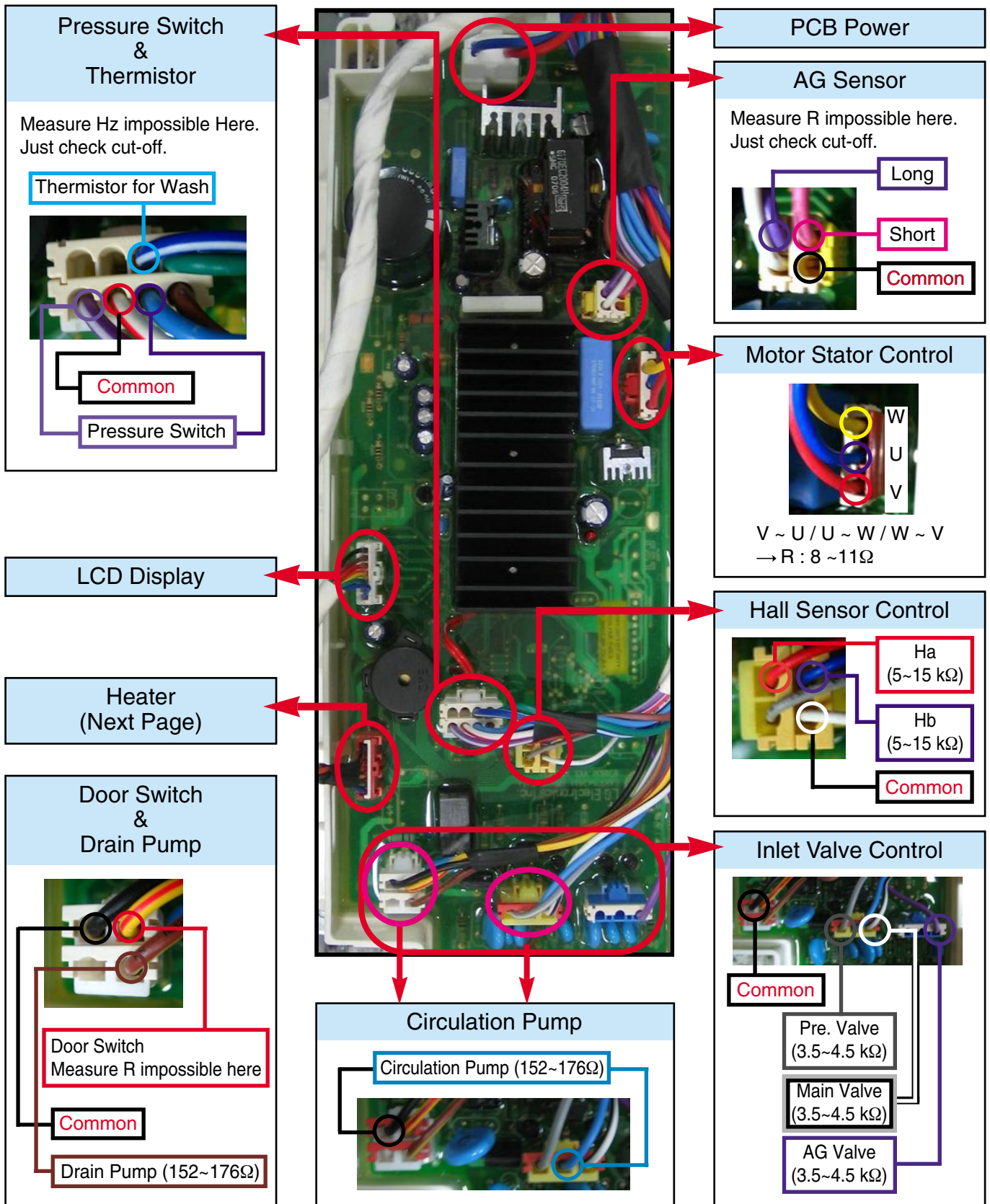

## ■ PCB Layout (Power)

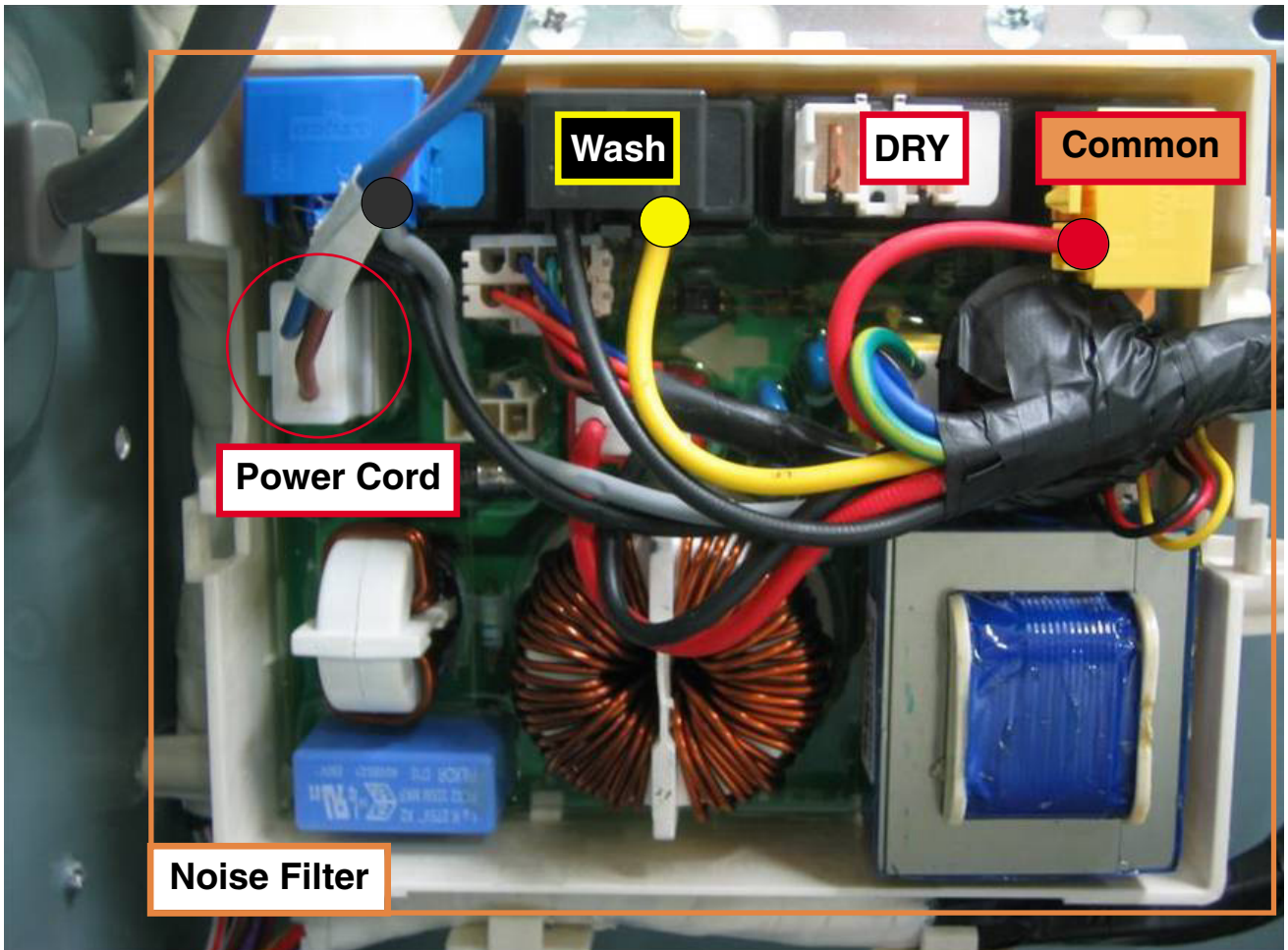

**Wash** Resistance : 24.5 ~ 28.5  $\Omega$

**DRY** Only For Dry Combo



# 7. TROUBLESHOOTING

## 7-1. BEFORE SVC CHECKING

- ① Before servicing ask the customer what the trouble is.
- ② Check the adjustments. (Power supply : 240V~, Removal of transit bolts etc..)
- ③ Check the troubles referring to the troubleshooting.
- ④ Decide service steps referring to disassembly instructions.
- ⑤ Then, service and repair.
- ⑥ After servicing, operate the appliance to see whether it works OK or NOT.

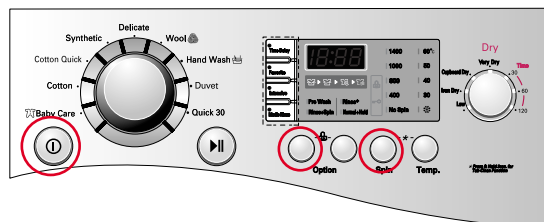

## 7-2. LOAD TEST MODE

- ① Press and Hold 'Option (Left)' & 'Rinse' buttons and then press 'Power' button.
- ② The washer must be empty and the controls must be in the off state.
- ③ Press Power with above two buttons pressed and then buzzer will sound.
- ④ Press the Start/Pause button repeatedly to cycle through the test modes

Number of times the Start/Pause button is pressed	Check Point	Display Status
None	Turns on all lamps and locks the door.	<b>QC TEST MODE</b>
1 time	Tumble clockwise.	rpm (42~50)
2 times	Low speed Spin.	rpm (55~65)
3 times	High speed Spin.	rpm (125~155)
4 times	Inlet valve for prewash turns on.	Water level frequency (25~65)
5 times	Inlet valve for main wash turns on.	Water level frequency (25~65)
6 times	Inlet valve for hot water turns on.	Water level frequency (25~65)
7 times	Inlet valve for bleach turns on.	Water level frequency (25~65)
8 times	Tumble counterclockwise.	rpm (42~50)
9 times	Heater turns on for 3 sec.	Water temperature
10 times	Circulation pump turns on.	Water level frequency (25~65)
11 times	Drain pump turns on.	Water level frequency (25~65)
12 times	Dry Fan / Dry Heater turn on.	Dry Fan 6min. / Dry Heater 5min.
13 times	Off	-

## 7-3. HOW TO CHECK THE WATER LEVEL FREQUENCY

※ Press the **Intensive** and **Option(Left)** button simultaneously.

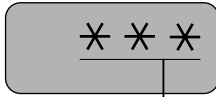

The digits means water level frequency. ( $10^{-1}$  kHz)  
 ex) 241 : Water level frequency =  $241 \times 10^{-1}$  kHz  
 24.1 kHz

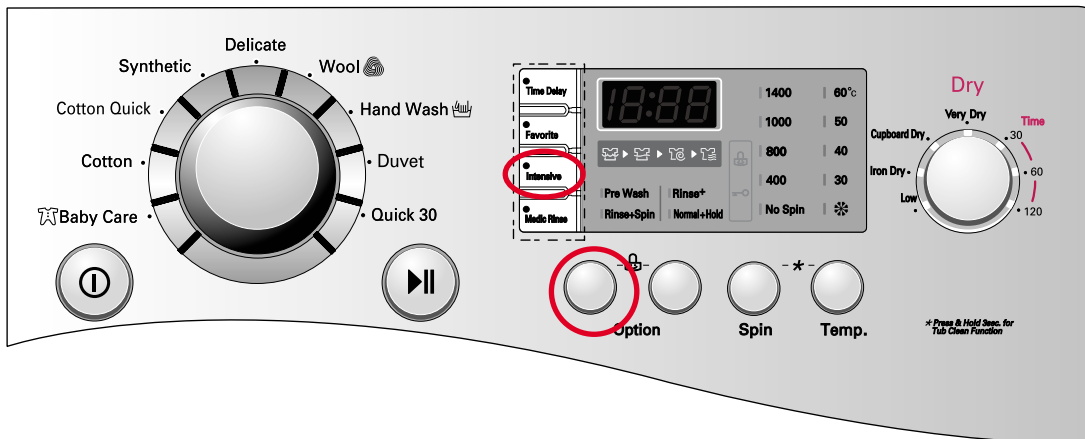

## 7-4. HOW TO KNOW TO TEMPERATURE OF EACH THERMISTOR AT OPERATING CONDITION.

※ Press the **Temp.** and **Option(Left)** button simultaneously.

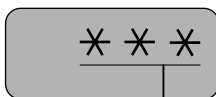

Thermistor in tub temperature.

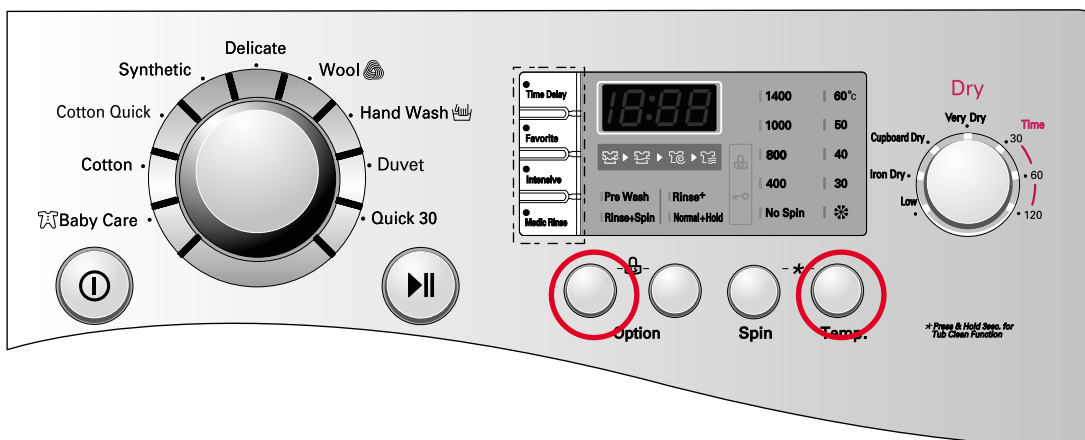

## 7-5. ERROR DISPLAY

- If you press the Start/Pause button in error condition, any error except 『PE』 will disappear and the machine will change into the pause status.
- In case of 『PE』, 『LE』, if the error is not resolved within 20 sec., and in case of other errors, if the error is not resolved within 4 min., power will be turned off automatically and the error only will be blinked. But in the case of 『FE』, power will not be turned off.

	ERROR	SYMPTOM	CAUSE
1	WATER INLET ERROR		<ul style="list-style-type: none"> <li>• Not reached to the water level(246) within 8 minutes after water supplied or not reached to the preset water level within 25 minutes. <a href="#">☞ Page 21</a></li> </ul>
2	WATER OUTLET ERROR		<ul style="list-style-type: none"> <li>• Not fully drained within 10 minutes. <a href="#">☞ Page 23</a></li> </ul>
3	OVERFLOW ERROR		<ul style="list-style-type: none"> <li>• Water is over flowing (over 8 level). ※ If " FE " is displayed, the drain pump operates to drain the water automatically. <a href="#">☞ Page 25</a></li> </ul>
4	PRESSURE SENSOR S/W ERROR		<ul style="list-style-type: none"> <li>• The sensor pressure switch is out of order. <a href="#">☞ Page 26</a></li> </ul>
5	DOOR OPEN ERROR		<ul style="list-style-type: none"> <li>• In case of operating the reservation function or the other function with door opened. Close the door, then the error display is resolved.</li> <li>• The door switch is out of order. <a href="#">☞ Page 27</a></li> </ul>
6	UNBALANCE ERROR		<ul style="list-style-type: none"> <li>• The appliance is tilted.</li> <li>• Laundry is gathered to one side. <a href="#">☞ Page 22</a></li> </ul>
7	THERMISTOR(HEATING) ERROR		<ul style="list-style-type: none"> <li>• The THERMISTOR is out of order. <a href="#">☞ Page 28</a></li> </ul>
8	MOTOR LOCKED ERROR		<ul style="list-style-type: none"> <li>• The connector in the LEAD WIRE ASSEMBLY is not connected to the connector of STATOR ASSEMBLY. <a href="#">☞ Reconnect or repair the connector.</a></li> <li>• The hall sensor is out of order/defective. <a href="#">☞ Replace the STATOR ASSEMBLY</a> <a href="#">☞ Page 29</a></li> </ul>
9	POWER FAILURE		<ul style="list-style-type: none"> <li>• The washer experienced a power failure <a href="#">☞ Page 34</a></li> </ul>
10	DRY HEATER ERROR		<ul style="list-style-type: none"> <li>• The Dry Heater is out of order</li> <li>• The Connector of the Dry Heater is not connected properly to the connector in the Main PWB ASSEMBLY</li> <li>• The Dry fan motor is out of order <a href="#">☞ Page 31</a></li> </ul>

## 7-6. TROUBLESHOOTING WITH ERROR

### Water Inlet Error (IE)

[Note] Environmental safety check list

1. No water tap leakage & freeze.
2. No entanglement of water supply hose.
3. No water shortage.
4. No water supply hose leakage.
5. No the inlet filter clogged.

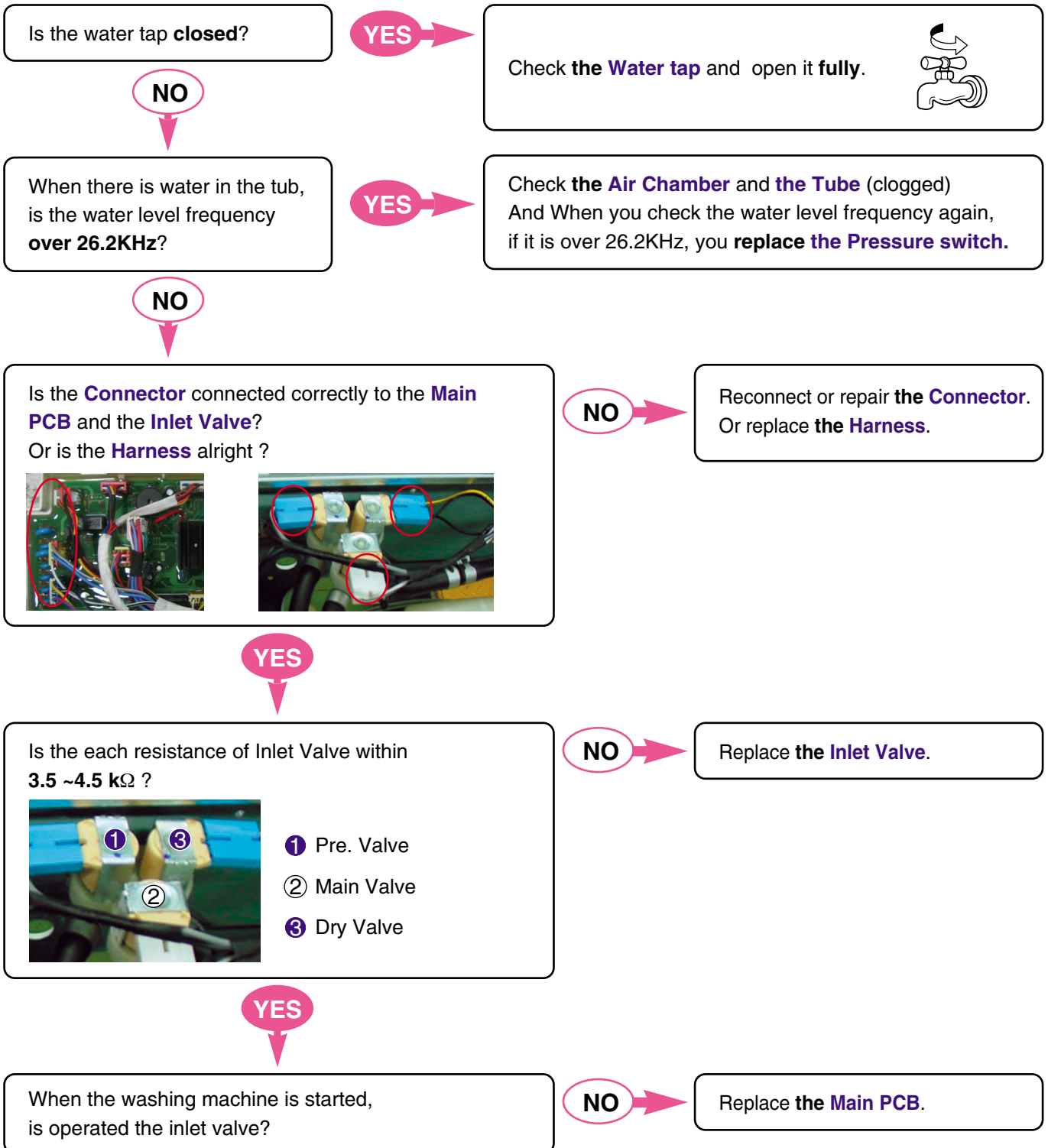

## Unbalanced Error (UE)

Does the load lean toward **one side**, or is the load a **few items**?

YES

The few items of clothing will clump together and their weight will be in one place on the drum, throwing the weight off during spin mode.

**So add some laundry to overcome UE error. And rearrange load to allow proper spinning.**

NO

Is the laundry **mixed**?

YES

Try **rearranging** the laundry in drum  
Or the laundry is **separated** by size, type, and color.



Separate by size,  
type and color



NO

Is the washing machine **installed** at an **angle**?

YES

Adjust the height of washing machine to be kept **horizontally**.  
(Page 7)

## Water Outlet Error (OE)

Is the drain hose kinked ?

YES

Check drain hose for kink and **straighten the Hose.**



Drain Hose



NO

Is the **Pump filter** clogged ?

YES

Check & Clean **Pump Filter.**

This kind of accumulation on the drain filter not only prevents proper drainage, but also will promote bacteria growth and cause odors. This drain filter should be cleaned once a month.

NO

Next Page

### \* How to disassemble and clean pump filter

Open the Cover by coin or finger(only new model)



Drain water by removing the hose cap.



Disassemble the pump filter by turning the filter cap counterclockwise.



Assemble & close cap

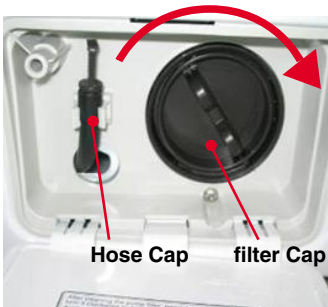

Filter clogged by foreign objects



Clean the filter



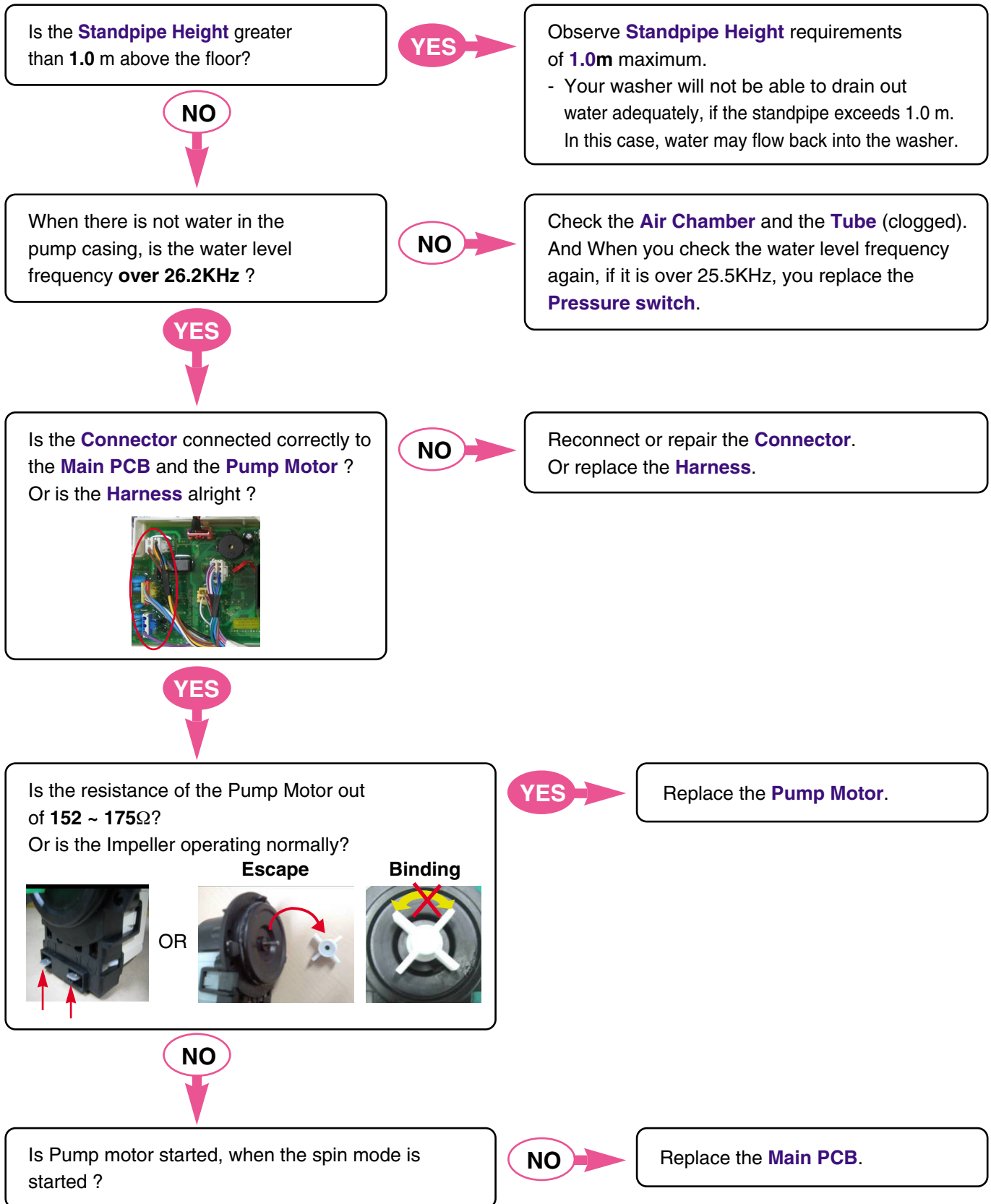

## Over Flow Error (FE)

Is the water coming in drawer **continuously**?



YES

Replace the **Inlet Valve assembly**.

NO

After power off for 10 sec. and power on.

Does the water level over reference line **and** Is **not** the water level frequency 26.2Khz ?

Or does **not** the water level over reference line **and** is the water level frequency 26.2Khz ?

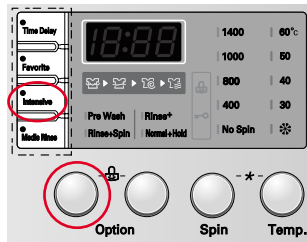

\* Water level frequency

- Press and Hold '**Intensive**' & '**Option(Left)**' simultaneously.

\* \* \*

• The digits means water level frequency. ( $10^{-1}$  kHz)  
ex) 241 : Water level frequency =  $241 \times 10^{-1}$  kHz  
24.1 kHz

YES

Replace the **Main PCB**.

NO

Check the **Air Chamber** and the **Tube** (clogged).

If FE is displayed again,  
then replace the **Pressure Switch**.

If FE is displayed again,  
then replace the **Main PCB**.

## Pressure Sensor S/W Error (PE)

Is the **Connector** connected correctly to the **Main PCB** and the **Pressure Switch** ?  
Or is the **Harness** alright ?

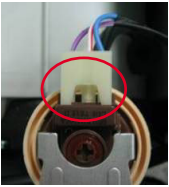
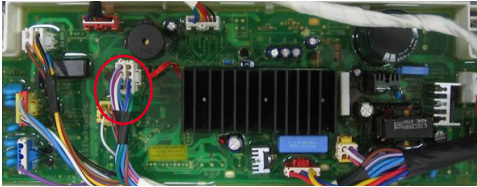

**NO**

Reconnect or repair the **Connector**.  
Or replace the **Harness**.

**YES**

Is the resistance of the **Pressure Switch** out of range?  
[Pin1 ~ Pin3  
→ **21~23Ω**)

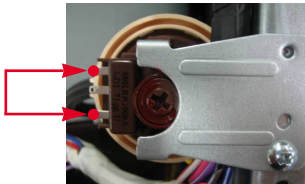

**YES**

Replace the **Pressure Switch**.

**NO**

Is the air chamber and the tube clogged?

**YES**

Check air chamber and remove the foreign material.

**NO**

Replace the **Main PCB**.

## Door Open Error (dE)

Is the door closed?

**NO**

Close the door totally.

**YES**

Is the Door assembly in line with door switch ?

**YES**

Lift up & Close the door.  
If the dE is displayed, Replace the **Door Bracket**.

Scratch by Latch Hook

or

Touching



**NO**

Does the **Spring** of **Latch Hook** actuate?

**NO**

Replace the **Latch Hook**.



**YES**

Is the **Connector** connected correctly to the **Main PCB** and the **Door Switch**?  
Or is the **Harness** alright ?

**NO**

Reconnect or repair the **Connector**.  
Or replace the **Harness**.

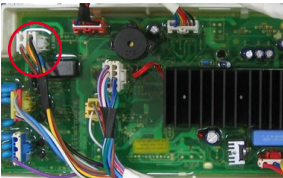

**YES**

Does the **Door Switch** operate as follows?

**NO**

Replace the **Door switch**.

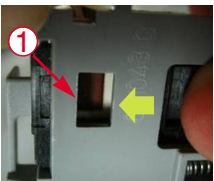

\* Door Locking time : 1~8 sec.  
Check the time between from input the power to parts ① move up, then Door locked.

\* Door Releasing time : 25~100 sec.  
Check the time between from off the power to parts ① move down, then Door released.

## Thermistor (Heating) Error (tE)

Is the **Connector** connected correctly to the **Main PCB** and the **Thermistor** and the **Heater**?  
Or is the **Harness** alright ?

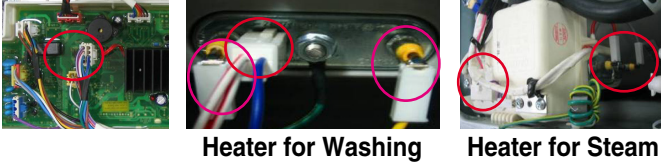

YES

Reconnect or repair the **Connector**.  
Or replace the **Harness**.

NO

Is the resistance of the **Thermistor** out of range **44 ~ 53 K $\Omega$**  at **25°C**? (Page 17)

YES

Replace the **Thermistor**.

NO

Is the resistance of the **Heater** out of range **24.5 ~ 28.5 $\Omega$**  (for Washing) or **42.5 ~ 49.5 $\Omega$**  (for Steam) ?  
(Page 19)

YES

Replace the **Heater**.

NO

Replace the **Main PCB**.

### [Note] Thermistor Spec

S P E C	Temp	Resistance (k $\Omega$ )		
		MIN	STD	MAX
	30 °C	36.35	39.45	42.72
	40 °C	24.20	26.05	27.97
	60 °C	11.43	12.12	12.82
	70 °C	8.088	8.514	8.940
	95 °C	3.544	3.791	4.045
	105 °C	2.617	2.816	3.023

## Motor Locked Error (LE)

[Pre Check]

- Gentle wash cycles, such as Perm Press, Delicates, Hand Wash, and Wool/Silk should only be used for smaller loads. Because these cycles are more gentle in tumbling and spinning, putting too much in the drum can register an issue with the motor. Remove items, reset unit and test with a Rinse/Spin cycle.
- Don't replace the PCB, when the hall sensor is replaced.  
Replace the PCB, when the LE is displayed after replacing the hall sensor.

Press the **Power** button & **Start / Pause** button.

Does the **Drum stop** when the start/pause button is pressed to start the cycle ?  
Or Sometimes does the **Drum rotate weakly** (under 15rpm)?

YES

Is the **Connector** connected correctly to the **Main PCB** and the **Motor**?  
Or is the **Harness** alright ?



NO

Reconnect or repair the **Connector**.  
Or replace the **Harness**.

YES

Disassemble the **Rotor**.  
Are the **Magnet** of rotor **cracked** or **broken**?



YES

Replace the **Rotor**.

NO

Are the resistance of the **Hall Sensor** 5~15kΩ?

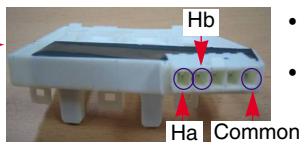

- Ha ~ Common : 5 ~ 15 kΩ
- Hb ~ Common : 5 ~ 15 kΩ

NO

Replace the **Hall Sensor**.  
→ Disassemble **hall sensor** carefully.  
**(Next page)**

YES

Are the resistance same between **Stator** points?

※ V~U / U~W / W~V : 8~11Ω



NO

Replace the **Stator**.

YES

Replace the **Main PCB**.

## 1 Disassemble the Hall Sensor

1) Disassemble the hook of Hall Sensor by (-) driver.



2) Pull up Hall Sensor slowly as shown in picture.



### ☆ Caution

If you disassemble by force, not following the directions, the hooks of stator (red circled) might break up. Hence need change of stator assembly.

**So disassemble cautiously.**

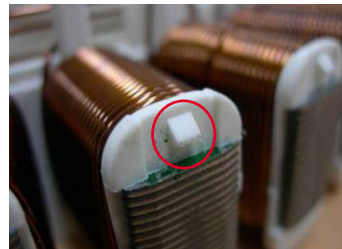

## 2 Assemble the Hall Sensor

1) Adjust the hole of Hall Sensor to the hooks of stator as picture. (red circled)



2) Push down the Hall sensor, and assemble to the hook for sure.



### [Note]

#### Hall Sensor Part No.

• 24" / 25" : 6501KW2001A

• 27" : 6501KW2002A

## Dry Heater Error (dHE)

Is the **Connector** connected correctly to the **Main PCB** and the **Dry Heater** or **Fan Motor**? Or is the **Harness** alright?

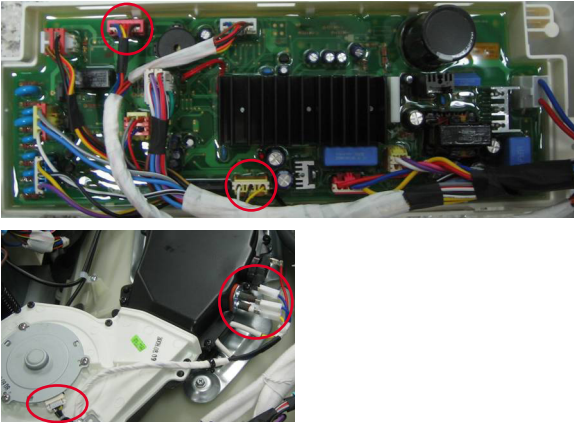

NO

Reconnect or repair the **Connector**.  
Or replace the **Harness**.

YES

Is the resistance of the **Thermistor** out of range **2.5~180KΩ** at **105~0°C**?

NO

Replace the **Thermistor**.

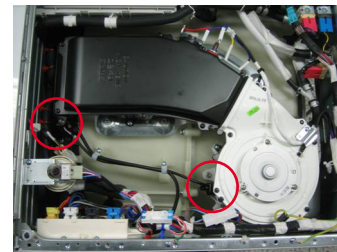

YES

Check for **Dry Heater** trouble.

📖 Page 24

Check for **Dry Fan Motor** trouble.

📖 Page 25

Disassemble the **Cabinet cover** and **Condensing Bellows**.  
Is there any foreign object in **Condensing Bellows**?

YES

Clean the **Bellows**.

NO

Disassemble the **Dry Fan Assy** and **Dry Duct Upper**,  
and clean foreign object in **Duct and Fan**.

## Dry Heater Trouble

After power off, is the resistance of **Dry Heater** out of range **33~37Ω**?

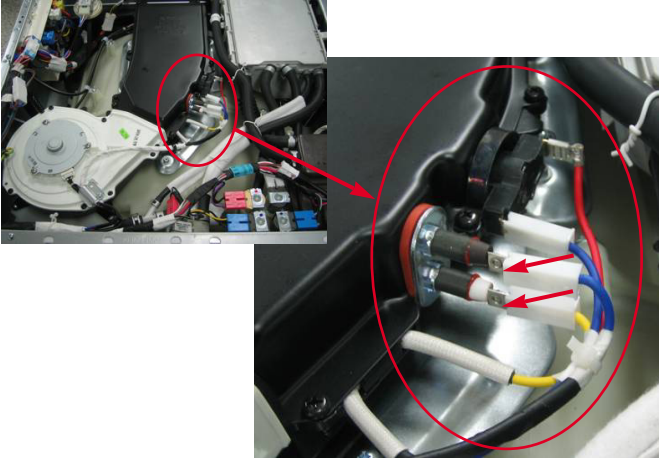

**NO**

Replace the **Dry Heater**.

**YES**

Is **Thermostat** closed ?

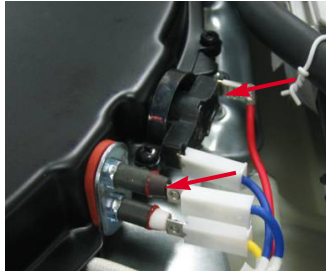

**NO**

Replace the **Thermostat**.

**YES**

When checking voltage between **connectors(1,2)** on drying, is the voltage AC **220-240V** as the figure ?

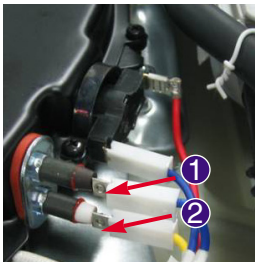

**NO**

Replace the **PWB assembly (main)**.

## Dry Fan Motor Trouble

Is the **Connector** connected correctly to the **Main PCB** and the **Dry Heater** or **Fan Motor** ?  
Or is the **Harness** alright?

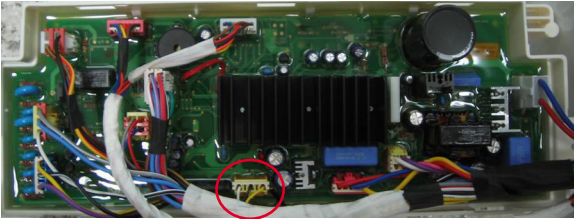

**NO**

Reconnect or repair the **Connector**.  
Or replace the **Harness**.

**YES**

Are the resistance same between **terminal** points?  
※  $V \sim U / U \sim W / W \sim V : 2 \sim 5 \Omega$

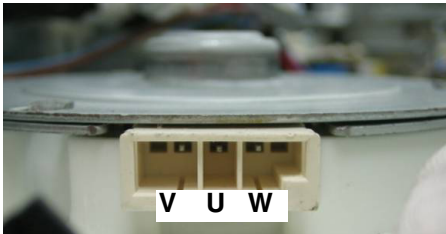

**NO**

Replace the **Dry Fan Motor**.

**YES**

When checking voltage between **connectors(1,2)** on drying, is the voltage DC **20~30V** as the figure ?

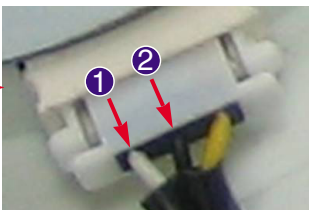

**NO**

Replace the **PWB assembly (main)**.

# 8. TROUBLESHOOTING WITHOUT ERROR CODES

## No Power

Is the Power Plug connected firmly to the power outlet?  
And is the supply voltage 220~240V AC?



**NO** → Reconnect **Power Plug** firmly.  
Check the fuse or reset the circuit breaker.

**YES**

Is Multi-plug socket used ?



**YES** → Don't use **Multi-plug** socket.  
Use **Single Plug** socket for washing machine.

**NO**

Is the **Connector** connected correctly to the **Main PCB** and the **Noise Filter**?  
Or is the **Harness** alright ?



**NO** → Reconnect or repair the **Connector**.  
Or replace the **Harness**.

**YES**

Is **Red LED ON** while power supplied ?



**NO** → Check and replace **Main PCB**.

**YES**

Is the connectors connected Correctly to the Display PCB?

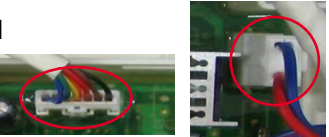

**YES** → Check connectors otherwise.  
Replace **Display PCB**.

## Vibration & Noise In Spin

Have all the **Transit Bolts** and the **Base Packing** been removed?

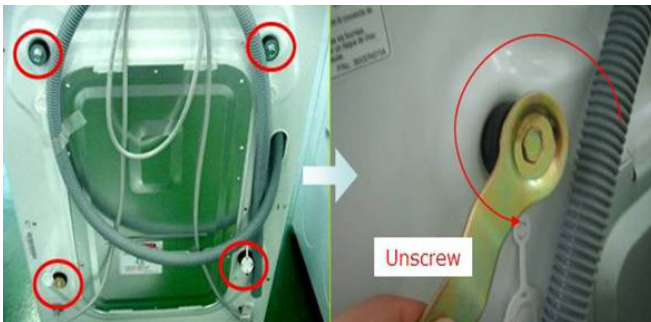
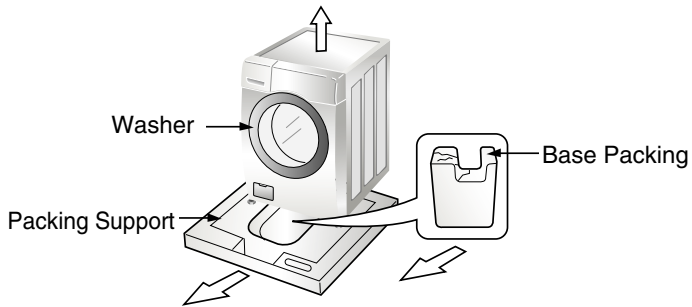

**NO**

Remove the **Transit Bolts** and the **Base Packing**.

**YES**

Refer to **INSTALLATION**. (Page 7)

# Detergent & Softener does not flow in

Is water supplied?

**NO** →

Refer to [Water Inlet Error (IE)]  
☞ (page 21)

**YES** ↓

Is detergent & softener put in the correct compartment of the drawer?

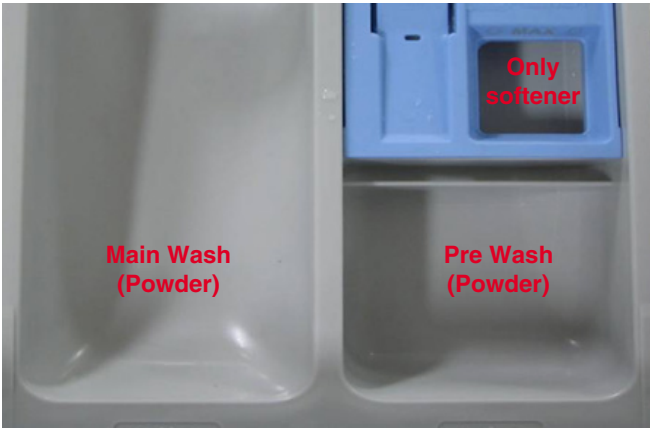

**NO** →

Put it in the **Correct Position**.

**YES** ↓

Is the **Detergent** caked or hardened?

※ Reference (Amount of Detergent & Softener)

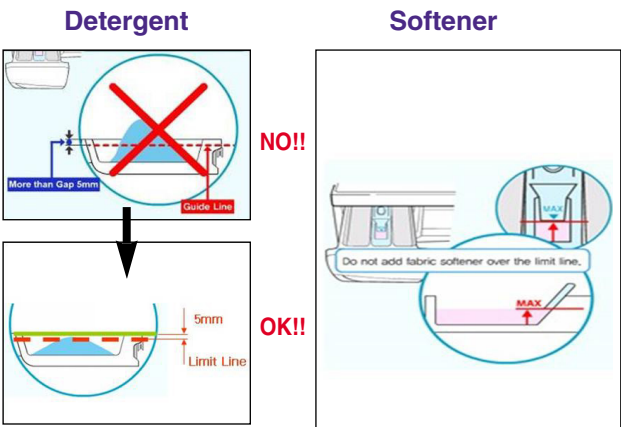

**YES** ↓

Clean the drawer and dispenser. ○ ※ Check point

# Water Leak

## 1. Water Leak from Dispenser

Is the **Dispenser Tray** Damaged or warped?



**YES**

Replace the **Dispenser Tray**.

**NO**

Is detergent & softener put in the correct compartment of the drawer?

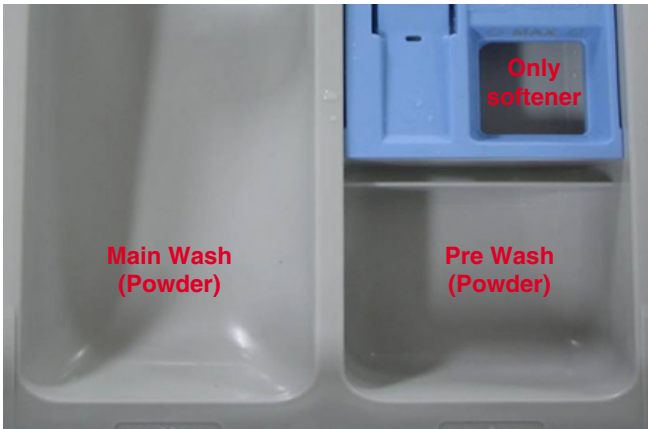

**NO**

Put it in the **Correct Position**.

※ Reference (Amount of Detergent & Softener)

**Detergent**

**Softener**

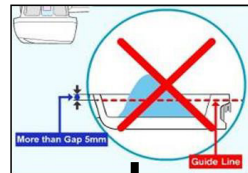

**NO!!**

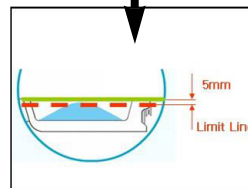

**OK!!**

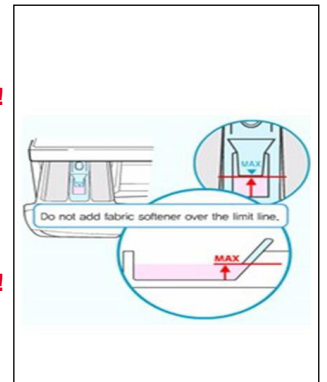

**YES**

Is the **Detergent** caked or hardened?

**YES**

Clean the drawer and dispenser.

○ ※ Check point

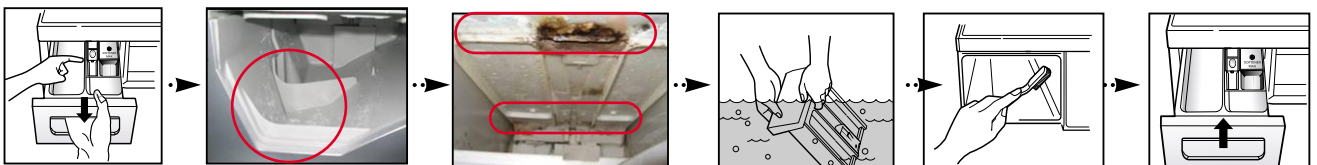

## 2. Water Leak from Dispenser

Are the gasket (seal) and door cleaned regularly?

**NO**

Clean the periphery of **Gasket** and **Door** regularly.



**YES**

Is the door or gasket damaged?

**YES**

Replace the damaged parts.

## 3. Unknown – Water on Floor

Are the inlet hoses loose or cracked/split?

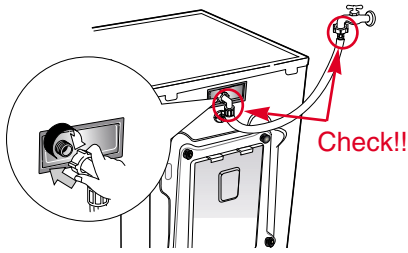

**YES**

Replace the **Inlet Hoses**.

**NO**

Is the washer horizontal ?

**NO**

Adjust the height of washing machine to be kept horizontally. (Page 7)

**YES**

Are the drain filter and manual drain hose open?

**NO**

Turn the filter cap clockwise to close.



# 9. DISASSEMBLY INSTRUCTIONS

\* Disassemble and repair the parts after pulling out power cord from the outlet.

## CONTROL PANEL

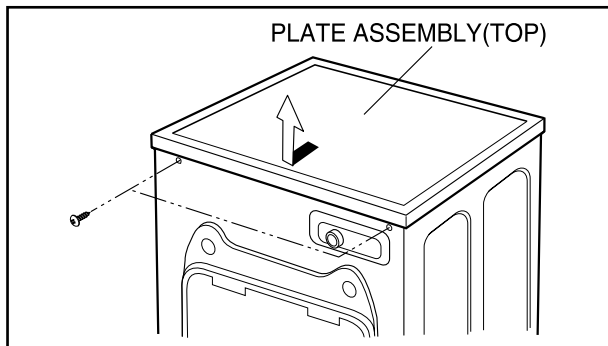

- ① Unscrew the screws on the top plate.
- ② The plate assembly(Top) is pulled back and then upward to arrow direction.
- ③ The cover(Inner) is disassembled.

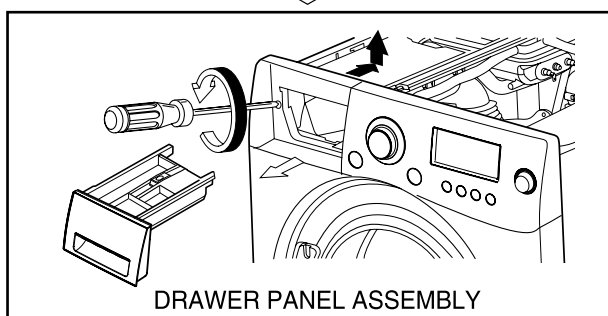

- ① Pull out the drawer and unscrew 2 screws.
- ② Lift the side the Control Panel Assembly and pull it out

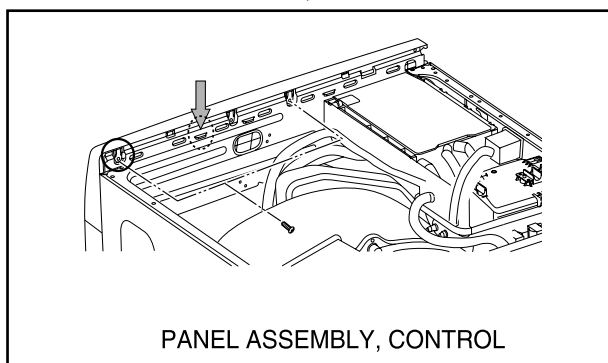

- ① Two screws is unscrewed.
- ② Push out PANEL ASSEMBLY, CONTROL after Push the hook below.

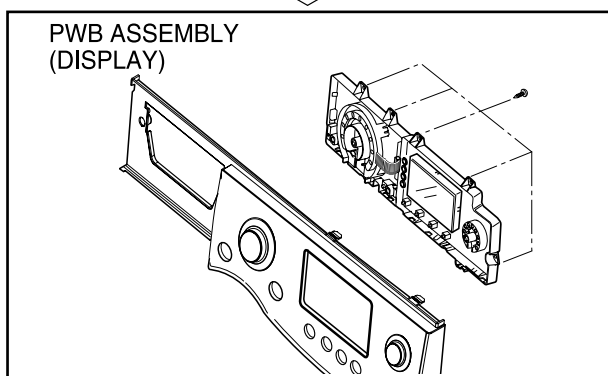

- ① The PWB assembly(Display) is disconnected.
- ② When 7 screws are unscrewed on the PWB insulator and the PWB assembly(Display) is disassembled from the PWB insulator.

## PWB ASSEMBLY(MAIN)

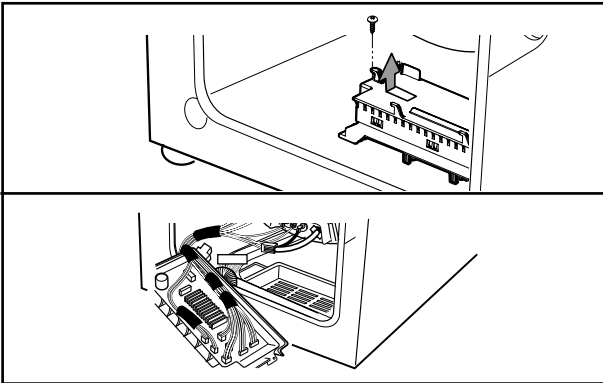

- ① The back cover is removed.
- ② One screw is unscrewed.
- ③ Pull the PWB assembly(Main) to arrow direction
- ④ Two screws is unscrewed.
- ⑤ The cover of PWB assembly(Main) is removed.
- ⑥ Disconnect connector from the wiring.

## PWB ASSEMBLY(POWER)

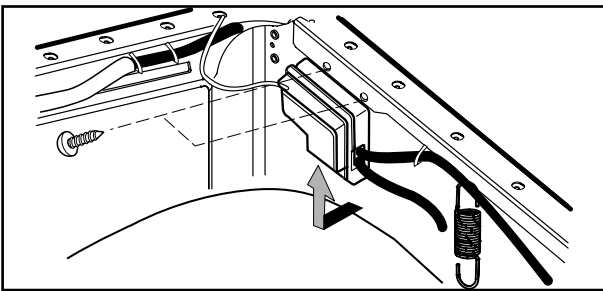

- ① The plate assembly(Top) disassembled.
- ② The cover of PWB assembly(Power) is removed.  
(Push the hook bellow.)
- ④ Disconnect connector from the PWB.
- ⑤ Two screw is unscrewed.

## DISPENSER ASSEMBLY

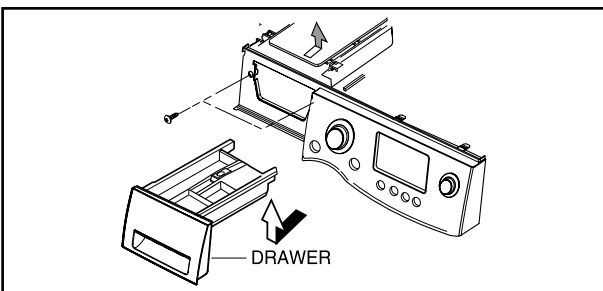

- ① The plate assembly(Top) are disassembled.
- ② Pull the drawer to arrow direction.
- ③ Two screws are unscrewed.

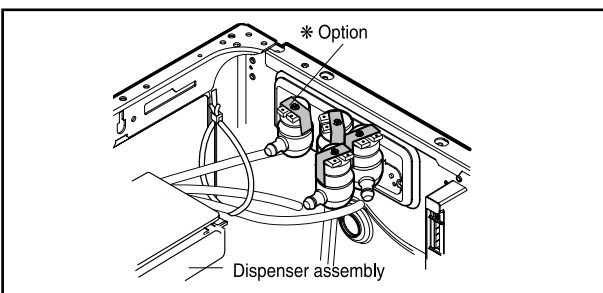

- ① The hose clamps and the hose are disassembled.
- ② The ventilation bellows are disassembled on the tub.

## INLET VALVE

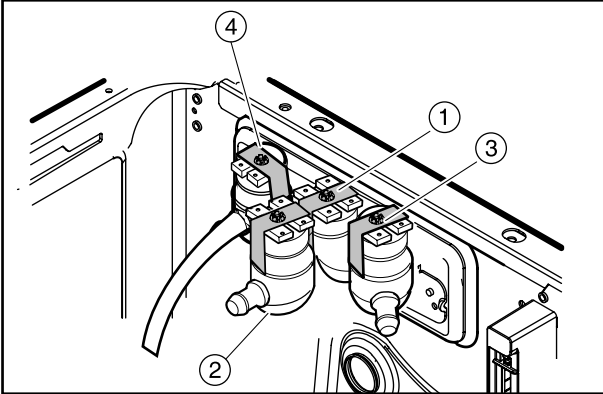

- ① Disconnect the wiring connector.
- ② Remove the valve by two screws of the valve holder.

※ When reconnecting the connector

VALVE ① (PRE)	GY/WH - BK
VALVE ② (MAIN)	WH/BK - BK
VALVE ③ (DRY)	YL/BK - BK
VALVE ④ (HOT)	BK/WH - BK

- Rating : 240V 50Hz
- Resistant : 3.5~4.5kΩ

## DOOR

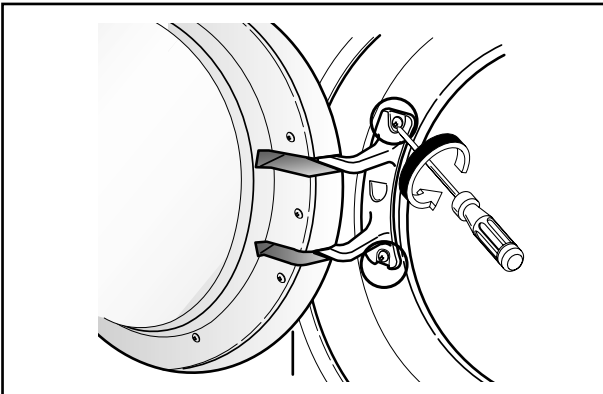

- ① Open the door completely.
- ② Remove the three screws from the hinge.

※ When removing the Door Assembly, it is necessary to hold the Bracket that is inner of the Cabinet Cover.

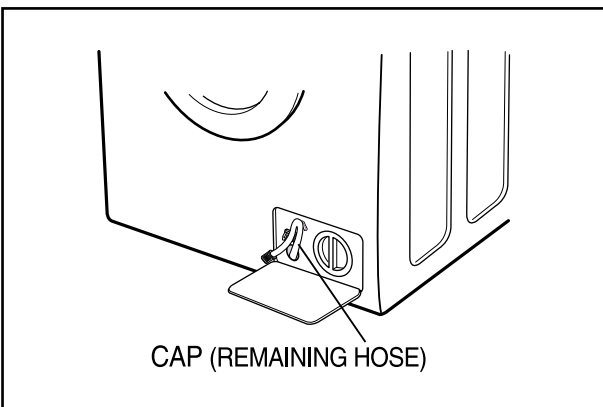

### Removing method of remained water

Pull it out from hose.

※ First, prepare a bucket to put in the remained water.

## CABINET COVER

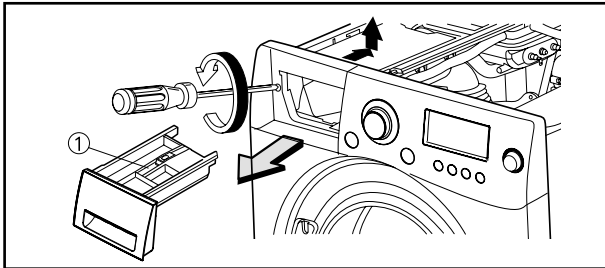

- ① The plate assembly(Top) is disassembled.
- ② Pull out the drawer and unscrew 2 screws.
- ③ Lift the side the Control Panel Assembly and pull it out

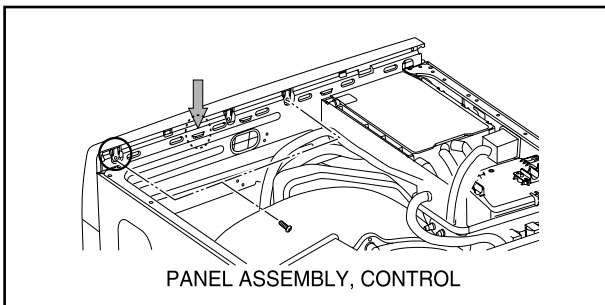

- ① Two screws is unscrewed.
- ② Push out PANEL ASSEMBLY, CONTROL after Push the hook(① , ②) below.

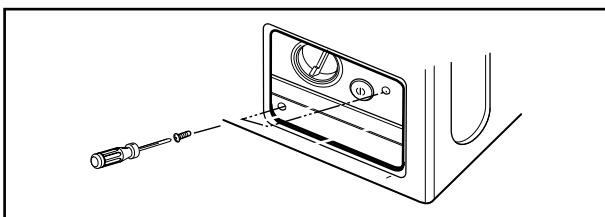

- ③ Unscrew the screws from the lower cover.

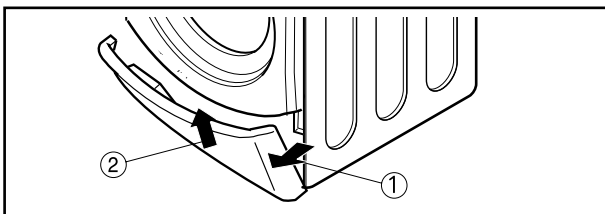

- ② The cabinet cover clamp is removed by special jig for service and the gasket is released.

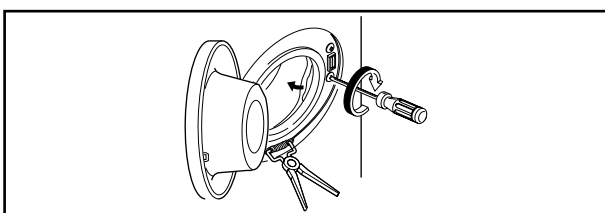

- ③ Two screws are unscrewed.

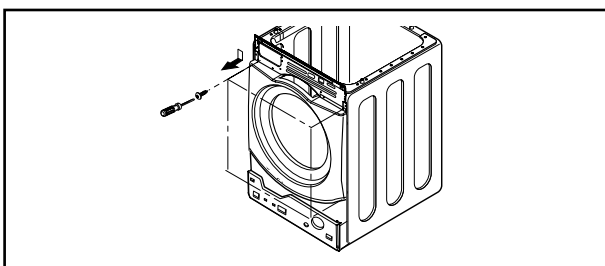

- ④ Unscrew all the screws on the upper and lower sides of the CABINET COVER.

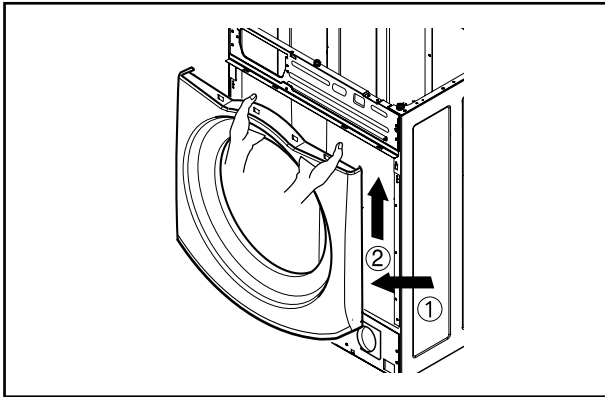

① Lift and separate the cabinet cover.

※ **NOTE:** When assembling the CABINET COVER, connect the Door S/W connector.

### SWITCH ASSY, DOOR LOCK

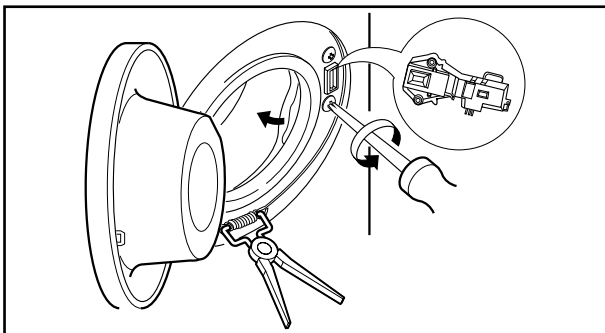

- ① The cabinet cover clamp is removed and the gasket is released.
- ② Two screws are unscrewed.
- ③ The Door Lock S/W is disconnected from the wiring connector and the strap.

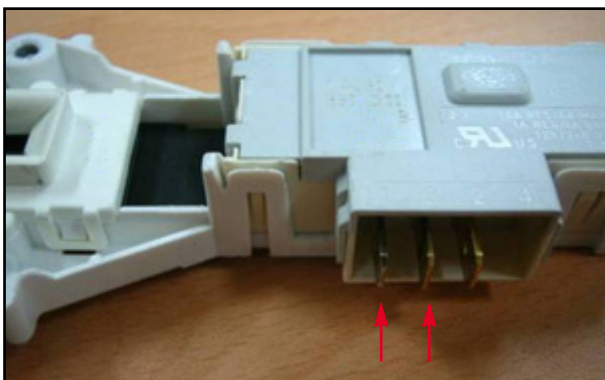

- Just check cut-off.
- Check the operating time.

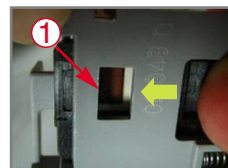

- \* Door Locking time : 1~8 sec.  
Check the time between from input the power to parts ① move up, then Door locked.
- \* Door Releasing time : 25~100 sec.  
Check the time between from off the power to parts ① move down, then Door released.

## ROTOR ASSEMBLY, STATOR ASSEMBLY, FRICTION DAMPER

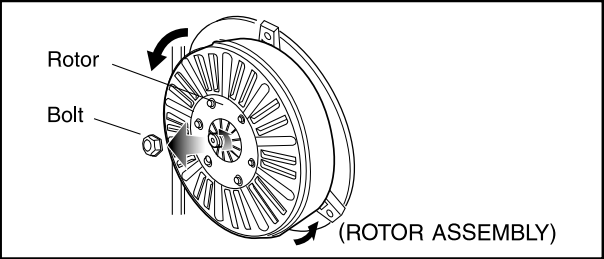

- ① Remove the back cover.
- ② After loosening the bolt, Rotor, pull out the rotor.

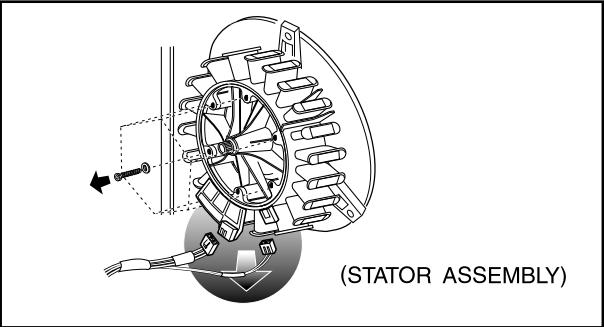

- ① Remove the 6 bolt from the stator.
- ② Disconnect the 2 connectors.

Motor Stator

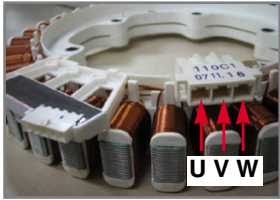

- V ~ U (8~11Ω)
- U ~ W (8~11Ω)
- W ~ V (8~11Ω)

Hall Sensor

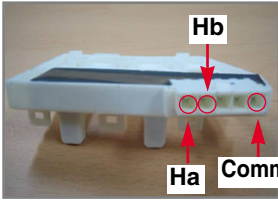

- Common ~ Ha (5~15kΩ)
- Common ~ Hb (5~15kΩ)

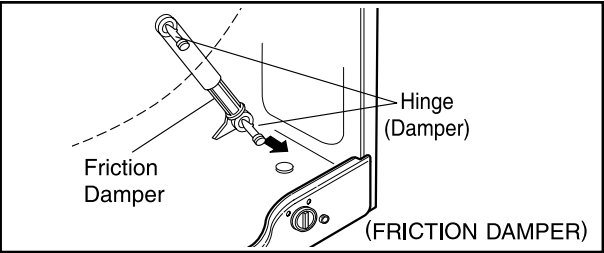

- ① Remove the hinges (Damper) at the Tub.
- ② The Hinge(Damper) at the base is pulled off pressing on the snaps at the sharp end.
- ③ The hinge at the base is pulled off. (To arrow direction)

## PUMP

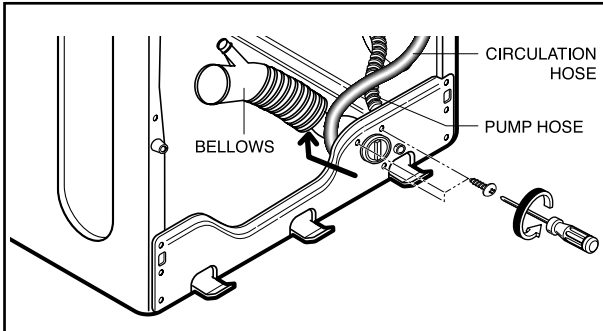

- ① Remove pump outlet hose.
- ② Remove tub pump bellows.
- ③ Remove cap(Remaining Hose).
- ④ Disconnect the wiring.
- ⑤ Three screws are unscrewed from the cabinet.
- ⑥ Remove the pump to arrow direction.

- Rating : 240V 50Hz
- Resistant : 162~176Ω

## HEATER

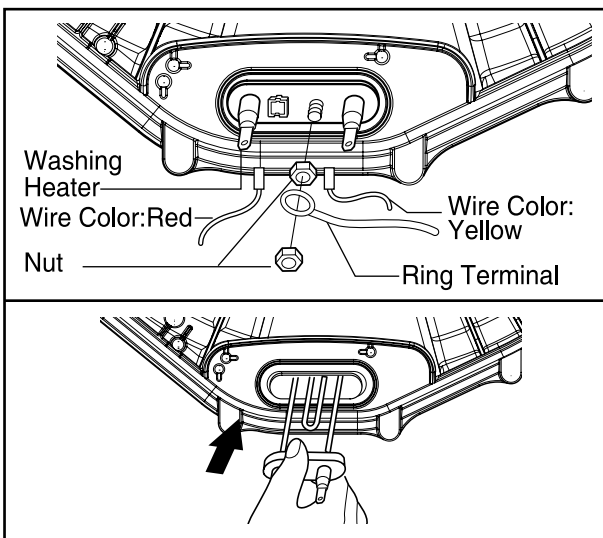

- ① Loosen the nut.
- ② Remove washing heater by pulling out.

- < Heater for Washing >
- Rating : 230V 2000W
  - Resistant : 24.5~28.5Ω

### CAUTION

When assembling the washing heater, insert the heater to heater clip on the bottom of tub and check the position of wire color.

## WHEN FOREIGN OBJECT STUCK BETWEEN DRUM AND TUB

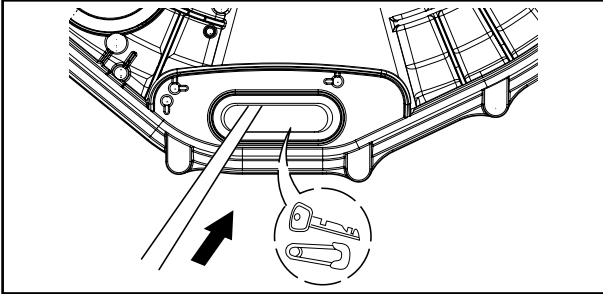

- ① Remove washing heater.
- ② Remove the foreign object(wire,coin,etc) by inserting long bar in the hole.

## SWITCH ASSEMBLY, SAFETY

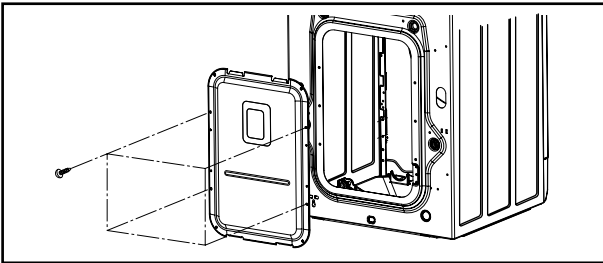

- ① Unscrew 4 screws from the back cover.

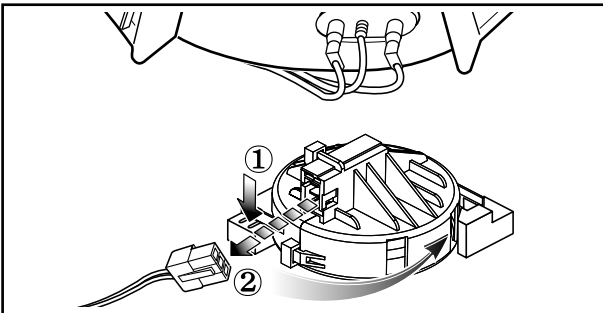

- ② Disconnect the wiring connector.
- ③ First, Press hook and turn the safety switch assembly switch assembly safety.

# 10. EXPLODED VIEW AND PART LIST

## 10-1. THE PART LIST OF CABINET ASSEMBLY

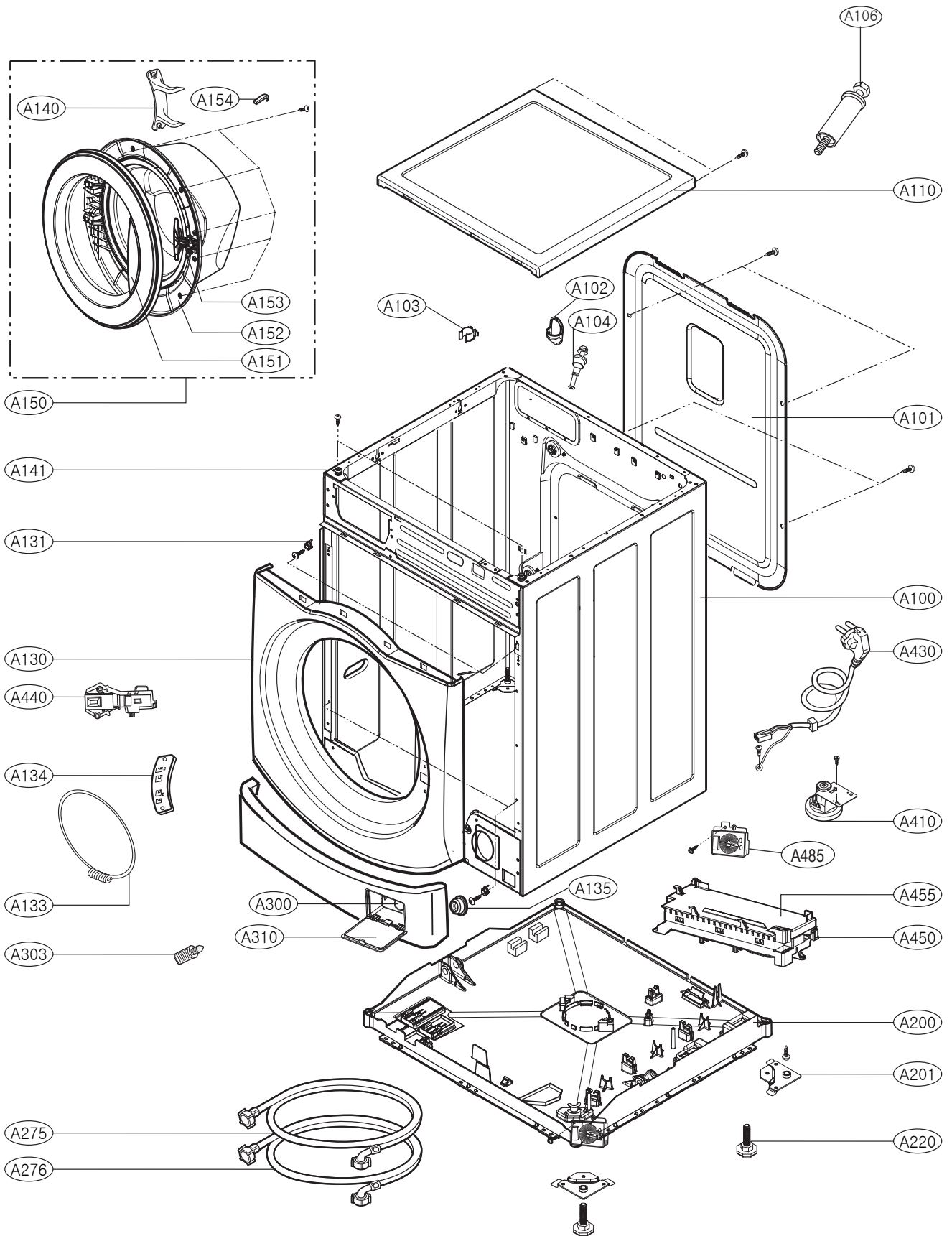

## 10-2. THE EXPLODED VIEW OF CONTROL PANEL & DISPENSER ASSEMBLY

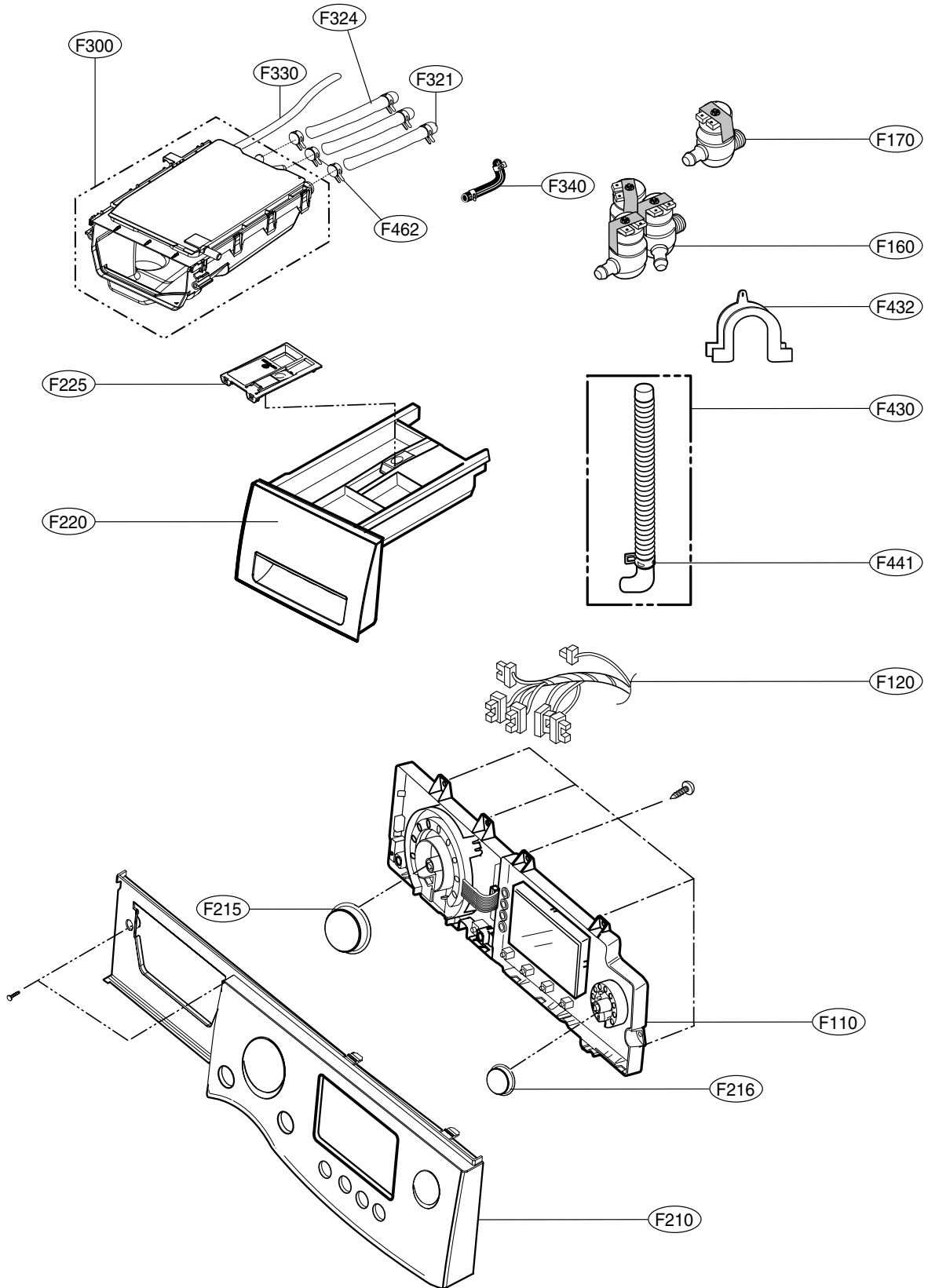

### 10-3. THE EXPLODED VIEW OF DRUM & TUB ASSEMBLY

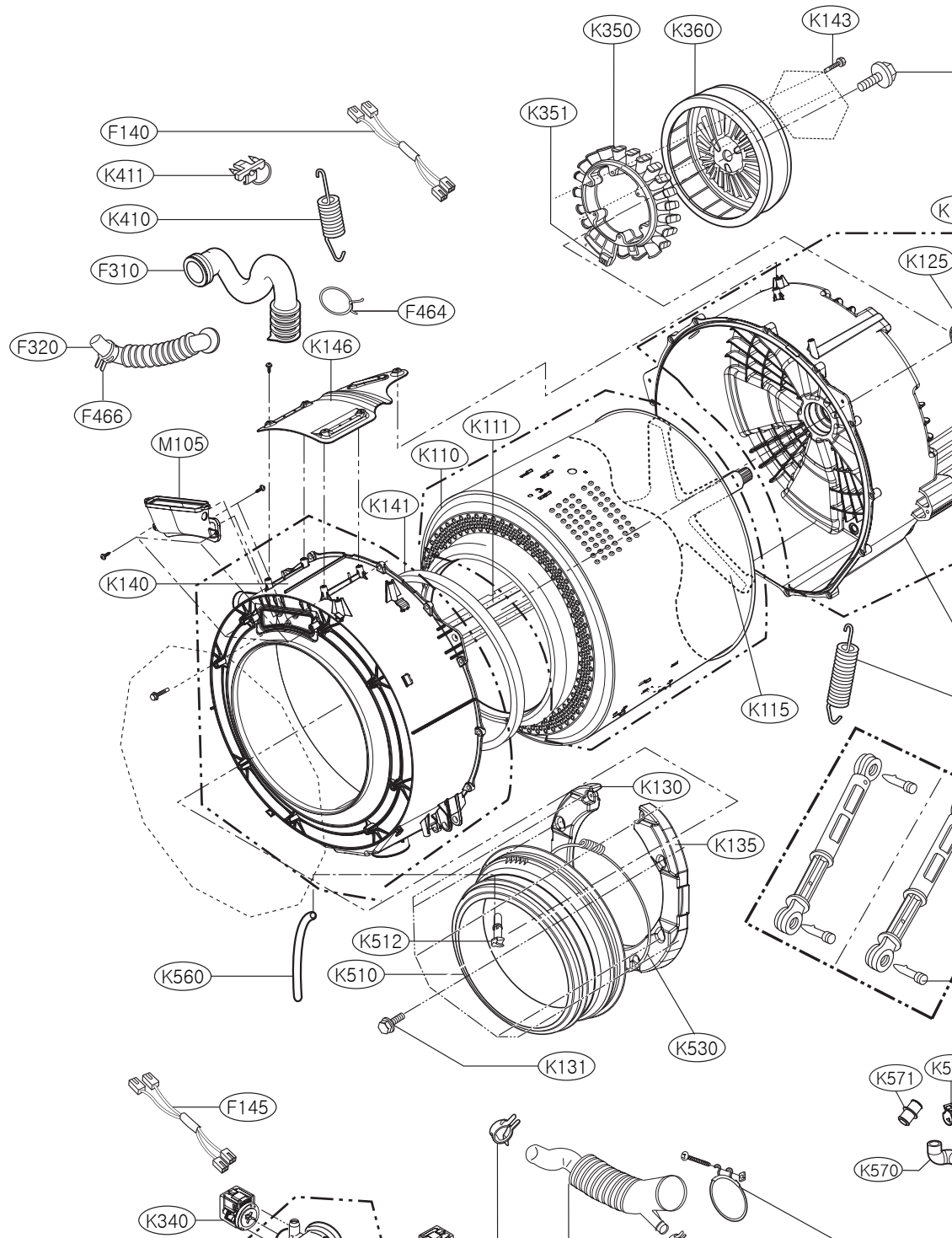

# 10-4. THE EXPLODED VIEW OF DRYER

