

Use & Care Guide
Manual de Uso y Cuidado

English / Español

Models/Modelos: 721.86002, 86003, 86009

Kenmore Elite®

Microwave Hood Combination

Combinación Microondas Campana

P/No.: MFL57601503
Sears Brands Management Corporation
Hoffman Estates, IL 60179 U.S.A.

www.kenmore.com
www.sears.com



Table of Contents

Warranty	2
Protection Agreements	3
Safety	4
Overview.....	7
How Your Microwave Hood Combination Works	7
Radio Interference	7
Testing Your Microwave Oven	7
Testing Your Dinnerware or Cookware	8
Operating Safety Precautions	8
Electrical Connection	8
Microwave Oven Features	9
Glass Tray Components.....	9
Installation Instructions for Glass Tray	10
Using an Oblong Dish	10
Oven Control Panel	11
How to Use	12
Dial Control	12
Function Selections	12
Clock	12
Timer	12
Vent	13
Light	13
Add 30 Seconds	13
Manual Cook	14
Two-Stage Cooking	14
Cooking Guide for Power Levels	15
Options	16
Soften/Melt	18
Control Lock	18
Back	18, 20
Favorites	19
Using Sensor Cooking	20
Popcorn	20
Cook	20
Reheat	20
Warm & Hold	21
Auto Defrost	22
Weight Conversion Chart	22
1 Lb Defrost	22
Defrosting Tips	22
Defrost Table	23
Care and Cleaning	25
Replacing the Cooktop and Oven Lights	26
Caring for the Filters	27
Cooking Tips	28
Questions and Answers	30
Troubleshooting	31
Service	Back Cover

Microwave Hood Combination Warranty

One Year Limited Warranty

When installed, operated and maintained according to all instructions supplied with the product, if this appliance fails due to a defect in material or workmanship within one year from the date of purchase, call 1-800-4-MY-HOME® to arrange for free repair.

Five-Year Limited Warranty on the Magnetron

For five years from the date of purchase, if the magnetron in this microwave oven fails due to a defect in material or workmanship, Sears will replace the magnetron. Safety regulations require the magnetron to be installed by Sears. After the first year, the customer assumes any labor costs associated with magnetron replacement.

If this appliance is used for other than private family purposes, this warranty applies for only 90 days from the date of purchase.

This warranty covers only defects in material and workmanship. Sears will NOT pay for:

1. Expendable items that can wear out from normal use, including but not limited to filters, belts, light bulbs, and bags.
2. A service technician to instruct the user in correct product installation, operation or maintenance.
3. A service technician to clean or maintain this product.
4. Damage to or failure of this product if it is not installed, operated or maintained according to all instructions supplied with the product.
5. Damage to or failure of this product resulting from accident, abuse, misuse or use for other than its intended purpose.
6. Damage to or failure of this product caused by the use of detergents, cleaners, chemicals or utensils other than those recommended in all instructions supplied with the product.
7. Damage to or failure of parts or systems resulting from unauthorized modifications made to this product.

Disclaimer of implied warranties; limitation of remedies:

Customer's sole and exclusive remedy under this limited warranty shall be product repair as provided herein. Implied warranties, including warranties of merchantability or fitness for a particular purpose, are limited to one year or the shortest period allowed by law. Sears shall not be liable for incidental or consequential damages. Some states and provinces do not allow the exclusion or limitation of incidental or consequential damages, or limitations on the duration of implied warranties of merchantability or fitness, so these exclusions or limitations may not apply to you.

This warranty applies only while this appliance is used in the United States and Canada.

This warranty gives you specific legal rights, and you may also have other rights which vary from state to state.

Sears, Roebuck and Co., Hoffman Estates, IL 60179
Sears Canada Inc., Toronto, Ontario, Canada M5B 2B8

Sears Service

Master Protection Agreements

Congratulations on making a smart purchase. Your new Kenmore® product is designed and manufactured for years of dependable operation. But like all products, it may require preventive maintenance or repair from time to time. That's when having a Master Protection Agreement can save you money and aggravation.

The Master Protection Agreement also helps extend the life of your new product. Here's what the Agreement* includes:

- **Parts and labor** needed to help keep products operating properly **under normal use**, not just defects. Our coverage goes **well beyond the product warranty**. No deductibles, no functional failure excluded from coverage – **real protection**.
- **Expert service** by a force of more than **10,000 authorized Sears service technicians**, which means someone you can trust will be working on your product.
- **Unlimited service calls and nationwide service**, as often as you want us, whenever you want us.
- **“No-lemon” guarantee** – replacement of your covered product if four or more product failures occur within twelve months.
- **Product replacement** if your covered product can't be fixed.
- **Annual Preventive Maintenance Check** at your request – no extra charge.
- **Fast help by phone** – we call it **Rapid Resolution** – phone support from a Sears representative on all products. Think of us as a “talking owner's manual.”
- Power surge protection against electrical damage due to power fluctuations.
- **\$250 Food Loss Protection** annually for any food spoilage that is the result of mechanical failure of any covered refrigerator or freezer.
- **Rental reimbursement** if repair of your covered product takes longer than promised.
- **10% discount** off the regular price of any noncovered repair service and related installed parts.

Once you purchase the Agreement, a simple phone call is all that it takes for you to schedule service. You can call anytime day or night, or schedule a service appointment online.

The Master Protection Agreement is a risk-free purchase. If you cancel for any reason during the product warranty period, we will provide a full refund or a prorated refund anytime after the product warranty period expires. Purchase your Master Protection Agreement today!

Some limitations and exclusions apply.

For prices and additional information in the U.S.A., call 1-800-827-6655.

*** Coverage in Canada varies on some items. For full details, call Sears Canada at 1-800-361-6665.**

Sears Installation Service

For Sears professional installation of home appliances, garage door openers, water heaters, and other major home items, in the U.S.A. or Canada call **1-800-4-MY-HOME®**.

Product Record

In the space to the right, record the date of purchase, model, and serial number of your product. You will find the model and serial number printed on an identification plate located inside the oven door. Have these items of information available whenever you contact Sears concerning your product.

Model No. _____

Date of Purchase _____

Serial No. _____

Save these instructions and your sales receipt for future reference.

Microwave Oven Safety

Your safety and the safety of others is very important.

We have provided many important safety messages in this manual and on your microwave oven. Always read and obey all safety messages.



This is the safety alert symbol.

This symbol alerts you to hazards that can kill or hurt you and others.

All safety messages will be preceded by the safety alert symbol and the word "DANGER" or "WARNING." These words mean:

 **DANGER**

You will be killed or seriously injured if you do not follow instructions.

 **WARNING**

You can be killed or seriously injured if you do not follow these instructions.

All safety messages will identify the hazard, tell you how to reduce the chance of injury, and tell you what can happen if the instructions are not followed.

IMPORTANT SAFETY INSTRUCTIONS

When using electrical appliances, basic safety precautions should be followed, including the following:

- ! WARNING:** To reduce the risk of burns, electric shock, fire, injury to persons, or exposure to excessive microwave energy:
- Read all instructions before using the microwave oven.
 - Read and follow the specific "PRECAUTIONS TO AVOID POSSIBLE EXPOSURE TO EXCESSIVE MICROWAVE ENERGY" found in this section.
 - The microwave oven must be grounded. Connect only to a properly grounded outlet. See "GROUNDING INSTRUCTIONS" found at the end of this section.
 - Install or locate the microwave oven only in accordance with the provided installation instructions.
 - Some products such as whole eggs in the shell and sealed containers, such as closed jars, can explode and should not be heated in the microwave oven.
 - Use the microwave oven only for its intended use as described in this manual.
 - Do not use corrosive chemicals or vapors in the microwave oven. This type of oven is specifically designed to heat, cook, or dry food. It is not designed for industrial or laboratory use.
 - As with any appliance, close supervision is necessary when used by children.
 - Do not operate the microwave oven if it has a damaged cord or plug, if it is not working properly, or if it has been damaged or dropped.

SAVE THESE INSTRUCTIONS

IMPORTANT SAFETY INSTRUCTIONS

- The microwave oven should be serviced only by qualified service personnel. Call an authorized service company for examination, repair, or adjustment.
- See door surface cleaning instructions in the “CARE AND CLEANING” section.
- To reduce the risk of fire in the oven cavity:
 - Do not overcook food. Carefully attend to the microwave oven when paper, plastic, or other combustible materials are placed inside the oven to facilitate cooking.
 - Remove wire twist-ties from paper or plastic bags before placing bags in oven.
 - If materials inside the oven ignite, keep the oven door closed, turn the oven off, and disconnect the power cord, or shut off power at the fuse or circuit breaker panel.
 - Do not use the oven cavity for storage purposes. Do not leave paper products, cooking utensils, or food in the oven cavity when not in use.
- This Microwave Oven is suitable for use above both gas and electric cooking equipment.
- This Microwave Oven is intended to be used above ranges with a maximum width of 36 inches (91 cm).
- Clean Ventilating Hoods frequently - grease should not be allowed to accumulate on the hood or filter.
- When flaming foods under the hood, turn the fan on.
- Use care when cleaning the vent-hood filter. Corrosive cleaning agents, such as lye-based oven cleaners, may damage the filter.
- Oversized foods or oversized metal utensils should not be inserted in the microwave oven, as they may start a fire or create risk of electric shock.
- Do not clean with metal scouring pads. Pieces can break off the pad and touch electrical parts causing a risk of electric shock.
- Do not store anything directly on top of the microwave oven when the microwave oven is in operation.
- Do not cover or block any openings on the microwave oven.
- Do not store this microwave oven outdoors.
- Do not use the microwave oven near water - for example, near a kitchen sink, in a wet basement, near a swimming pool, or similar location.
- Do not immerse the cord or plug in water.
- Keep the cord away from heated surfaces.
- Do not let the cord hang over the edge of a table or counter.
- Do not mount the oven over a sink.
- Do not cover the racks or any other part of the oven with metal foil. Doing so will cause the oven to overheat.
- Liquids such as water, coffee, or tea can be overheated beyond the boiling point without appearing to be boiling, due to surface tension of the liquid. Visible bubbling or boiling when the container is removed from the microwave oven is not always present. **This could result in very hot liquids suddenly boiling over when a spoon or other utensil is inserted into the liquid.** To reduce the risk of injury to persons:
 - 1) Do not overheat the liquid.
 - 2) Stir the liquid before and halfway through heating it.
 - 3) Do not use straight-sided containers with narrow necks.
 - 4) After heating, allow the container to stand in the microwave oven for a short time before removing the container.
 - 5) Use extreme caution when inserting a spoon or other utensil into the container.

SAVE THESE INSTRUCTIONS

PRECAUTIONS TO AVOID POSSIBLE EXPOSURE TO EXCESSIVE MICROWAVE ENERGY

- (a) Do not attempt to operate this oven with the door open. Doing so can result in harmful exposure to microwave energy. It is important not to defeat or tamper with the safety interlocks.
- (b) Do not place any object between the oven front face and the door, or allow soil or cleanser residue to accumulate on sealing surfaces.
- (c) Do not operate the oven if it is damaged. It is particularly important that the oven door closes properly and that there is no damage to the:
 - (1) Door (bent)
 - (2) Hinges and latches (broken or loosened)
 - (3) Door seals and sealing surfaces
- (d) The oven should not be adjusted or repaired by anyone except for a properly qualified service technician.

ELECTRICAL REQUIREMENTS

Observe all governing codes and ordinances. A 120-Volt, 60-Hz, AC-only, 20-amp fused electrical supply is required. A time delay fuse is recommended. It is recommended that a separate circuit, serving only this appliance, be provided.

⚠ DANGER

Electrical Shock Hazard
Plug into a grounded 3-prong outlet. Do not remove ground prong. Do not use an adapter cord. Failure to follow these instructions can result in electrical shock, fire, or death.



GROUNDING INSTRUCTIONS

For all cord-connected appliances:
The microwave oven must be grounded. In the event of an electrical short circuit, grounding reduces the risk of electric shock by providing an escape wire for the electric current. The microwave oven is equipped with a cord having a grounding wire with a grounding plug. The plug must be plugged into an outlet that is properly installed and grounded.

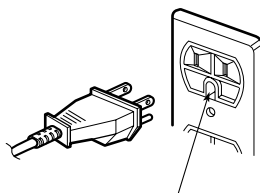

Ensure proper ground exists before use

⚠ WARNING: Improper grounding can result in a risk of electric shock. Consult a qualified electrician or service technician if you do not understand the grounding instructions or if doubt exists whether the appliance is properly grounded. Do not use an extension cord. If the power supply cord is too short, have a qualified electrician or service technician install an outlet near the microwave oven.

For a permanently connected appliance:
This appliance has a short power supply cord to reduce the risk of anyone tripping over or becoming entangled in the cord. The microwave oven must be connected to a grounded, metallic, permanent wiring system, or an equipment grounding conductor should be run with the circuit conductors and connected to the equipment grounding terminal or lead on the microwave oven.

SAVE THESE INSTRUCTIONS

Overview

This section discusses the concepts behind microwave cooking. It also discusses the basic information you need to know to operate your microwave oven. Please read this information before you use your oven.

HOW YOUR MICROWAVE HOOD COMBINATION WORKS

Microwave ovens are safe. Microwave energy is not hot. It causes food to make its own heat, and it is this heat that cooks the food.

Microwaves are like TV waves, radio waves, or light waves. You cannot see them, but you can see what they do.

A magnetron in the microwave oven produces microwaves. The microwaves move into the oven where they contact the food as it turns on the turntable.

The glass turntable of your microwave oven lets microwaves pass through. Then they bounce off a metal floor, back through the glass turntable, and are absorbed by the food.

Microwaves pass through most glass, paper, and plastics without heating them, so food absorbs the energy. Microwaves bounce off metal containers so food does not absorb the energy.

Sensor Cooking

This Microwave System features Sensor Cooking functions. A humidity sensor in the oven cavity detects moisture and humidity emitted from food as it heats. The sensor adjusts cooking times to various types and amounts of food. Sensor Cooking takes the guesswork out of microwave cooking.

For the best cooking results

- Always cook food for the shortest cooking time recommended. Check to see how the food is cooking.
- Stir, turn over, or rearrange the food being cooked about halfway through the cooking time for all recipes. This will help make sure the food is evenly cooked.
- If you do not have a cover for a dish, use wax paper, or microwave-approved paper towels or plastic wrap. Remember to turn back a corner of the plastic wrap to vent steam during cooking.
- Always remove the cooking rack from the oven when the rack is not in use.

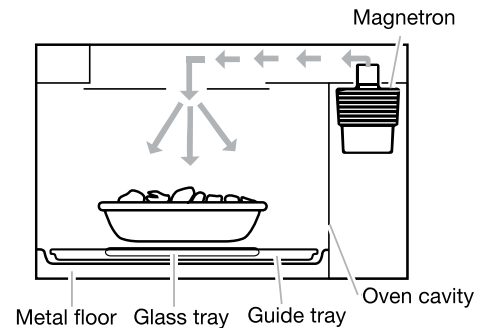

RADIO INTERFERENCE

Using your microwave oven may cause interference to your radio, TV, or similar equipment. When there is interference, you can reduce it or remove it by:

- **Cleaning** the door and sealing surfaces of the oven.
- **Adjusting** the receiving antenna of the radio or television.
- **Moving** the receiver away from the microwave oven.
- **Plugging** the microwave oven into a different outlet so that the microwave oven and receiver are on different branch circuits.

TESTING YOUR MICROWAVE OVEN

To test the oven, put approximately 1 cup of cold water in a glass container in the oven. Close the door. Cook at 100% power for 1 minute. When the time is up, the water should be heated.

TESTING YOUR DINNERWARE OR COOKWARE

Most heat resistant, nonmetallic cookware is safe for use in your microwave oven. However, to test cookware before using, follow these steps:

1. Place empty cookware in the microwave oven.
2. Measure 1 cup (250ml) of water in a glass measuring cup and place it in the oven beside the cookware.
3. Microwave on 100% power for 1 minute. If the cookware is warm, it should not be used for microwave cooking.

NOTE:

Some dishes (melamine, some ceramic dinnerware, etc.) absorb microwave energy, becoming too hot to handle and slowing cooking time. Cooking in metal containers, not designed for microwave use, could damage the oven, as could containers with hidden metal (twist-ties, foil lining, staples, metallic glaze or trim).

OPERATING SAFETY PRECAUTIONS

- **Never** lean on the door or allow a child to swing on it when the door is open.
- **Use hot pads.** Microwave energy does not heat containers, but the heat from the food can make the container hot.
- **Do not use newspaper or other printed paper in the oven.**
- **Do not** dry flowers, fruit, herbs, wood, paper, gourds, or clothes in the oven.
- **Do not** start the microwave oven when it is empty or product life may be shortened. If you practice programming the oven, put a container of water in the oven. It is normal for the oven door to look wavy after the oven has been running for a while.
- **Do not** try to melt paraffin wax in the oven. Paraffin wax will not melt in a microwave oven because it allows microwaves to pass through it.
- **Do not** operate the microwave oven unless the glass turntable is securely in place and can move freely. The turntable can move in either direction. **Make sure** the turntable is correct-side up in the oven. **Handle your turntable with care** when removing it from the oven to avoid possibly breaking it. If your turntable cracks or breaks, contact your dealer for a replacement.
- **When you use a browning dish**, the browning dish bottom must be at least 3/16 inch above the turntable. Follow the directions supplied with the browning dish.
- **Never cook or reheat a whole egg inside the shell.** Steam buildup in whole eggs may cause them to burst, and possibly damage the oven. **Slice** hard-boiled eggs before heating. In rare cases, poached eggs have been known to explode. **Cover** poached eggs and **allow a standing time** of one minute before cutting into them.
- **For best results, stir any liquid several times during heating or reheating.** Liquids heated in certain containers (especially containers shaped like cylinders) may overheat. The liquid may splash out with a loud noise during or after heating or when adding ingredients (coffee granules, tea bags, etc.). This can harm you or damage the microwave oven.
- **Microwaves** may not reach the center of a roast. The heat spreads to the center from the outer, cooked areas just as in regular oven cooking. This is one of the reasons for letting some foods (for example, roasts or baked potatoes) stand for a while after cooking, or for stirring some foods during the cooking time.
- **Do not deep fry in the oven.** Microwavable utensils are not suitable and it is difficult to maintain appropriate deep-frying temperatures.
- **Do not overcook potatoes.** At the end of the recommended cooking time, potatoes should be slightly firm because they will continue cooking during standing time. **After microwaving, let potatoes stand** for five minutes. They will finish cooking while standing.

ELECTRICAL CONNECTION

If your electric power line or outlet voltage is less than 110 volts, cooking times may be longer. Have a qualified electrician check your electrical system.

MICROWAVE OVEN FEATURES

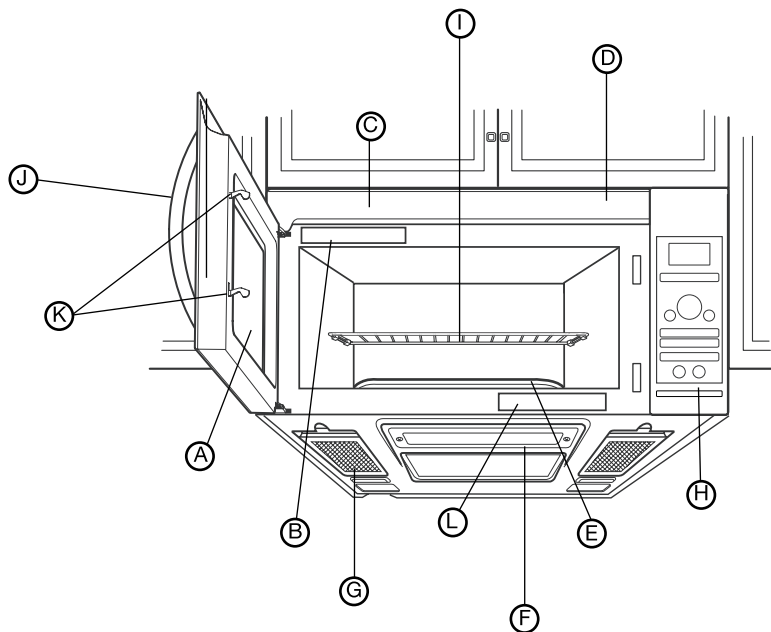

Your microwave oven is designed to make your cooking experience as enjoyable and productive as possible. To get you up and running quickly, the following is a list of the oven's basic features:

- A. Metal Shielded Window** - The shield prevents microwaves from escaping. It is designed as a screen to allow you to view food as it cooks.
- B. Model and Serial Number Plate**
- C. Charcoal Filter (behind Vent Grille)**
- D. Vent Grille**
- E. Glass Turntray/Guide Tray** - The glass tray moves food as it cooks for more even cooking. It must be in the oven during operation for best cooking results. **NOTE:** The Even Glide Plus system is capable of handling dishes up to 12 x 15 inches.

- F. Cooktop/Countertop Light**
- G. Grease Filter** - See "CARING FOR THE FILTERS" section.
- H. Control Panel** - Touch the pads on this panel to perform all functions.
- I. Cooking Rack** - Use for extra space when cooking in more than one container at the same time. Remove cooking rack when you are not using it.
- J. Door Handle**
- K. Door Safety Lock System**
- L. Cooking Guide Label**

GLASS TRAY COMPONENTS

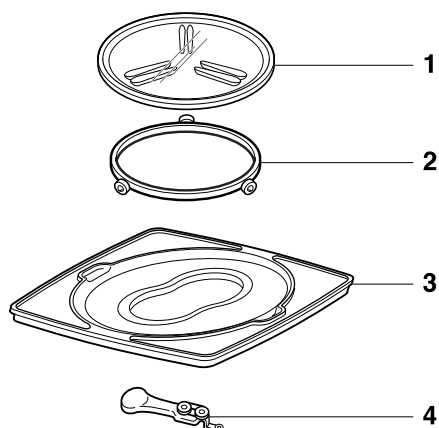

1. Glass tray
2. Rotating ring
3. Guide tray
4. Shaft

The glass tray moves in both directions and turns to help cook food more evenly. Do not operate the microwave oven without the glass tray in place.

INSTALLATION INSTRUCTIONS FOR GLASS TRAY

To install:

1. Place the guide tray on the oven cavity bottom. The rollers on the shaft should fit inside the guide tray bottom groove. (See figures 1, 2-1, and 2-2)
2. Place the rotating ring on the guide tray. (See Figure 3)
3. Place the glass tray on the rotating ring. Fit the rollers of the shaft between the raised, hollowed groove of the glass tray bottom. The rollers on the rotating ring should fit inside the glass tray bottom ridge. (See Figures 4-1 and 4-2)

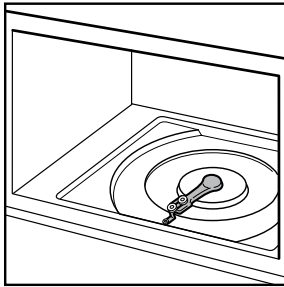

Figure 1

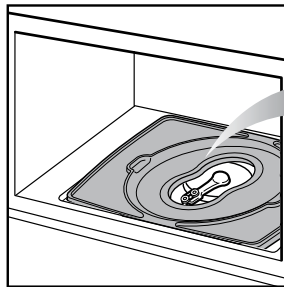

Figure 2-1

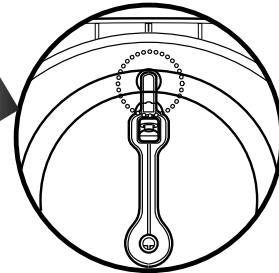

Figure 2-2

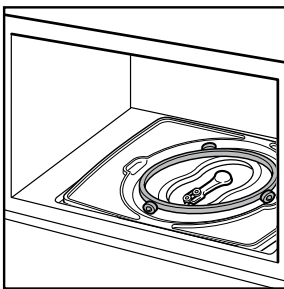

Figure 3

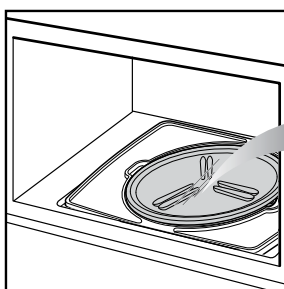

Figure 4-1

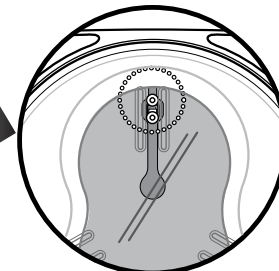

Figure 4-2

USING AN OBLONG DISH

When using an oblong dish, don't forget to place it in the center of the guide tray, or poor performance will result. An oblong dish which is smaller than 13 inches should be placed on the glass tray. A dish larger than 13 inches should be placed on the raised edge of the guide tray preventing it from touching the glass tray. Otherwise, poor performance will result. (See Figure 6)

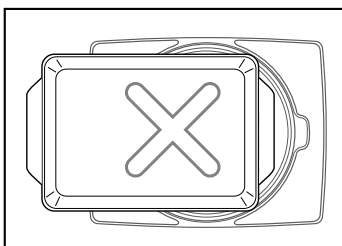

Figure 5

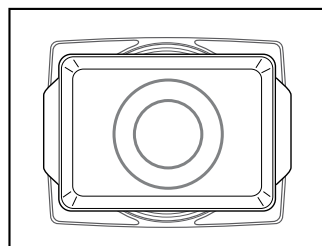

Figure 6

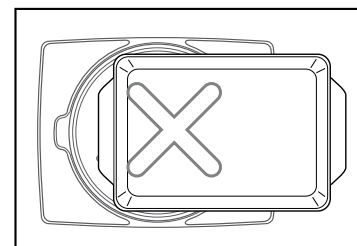
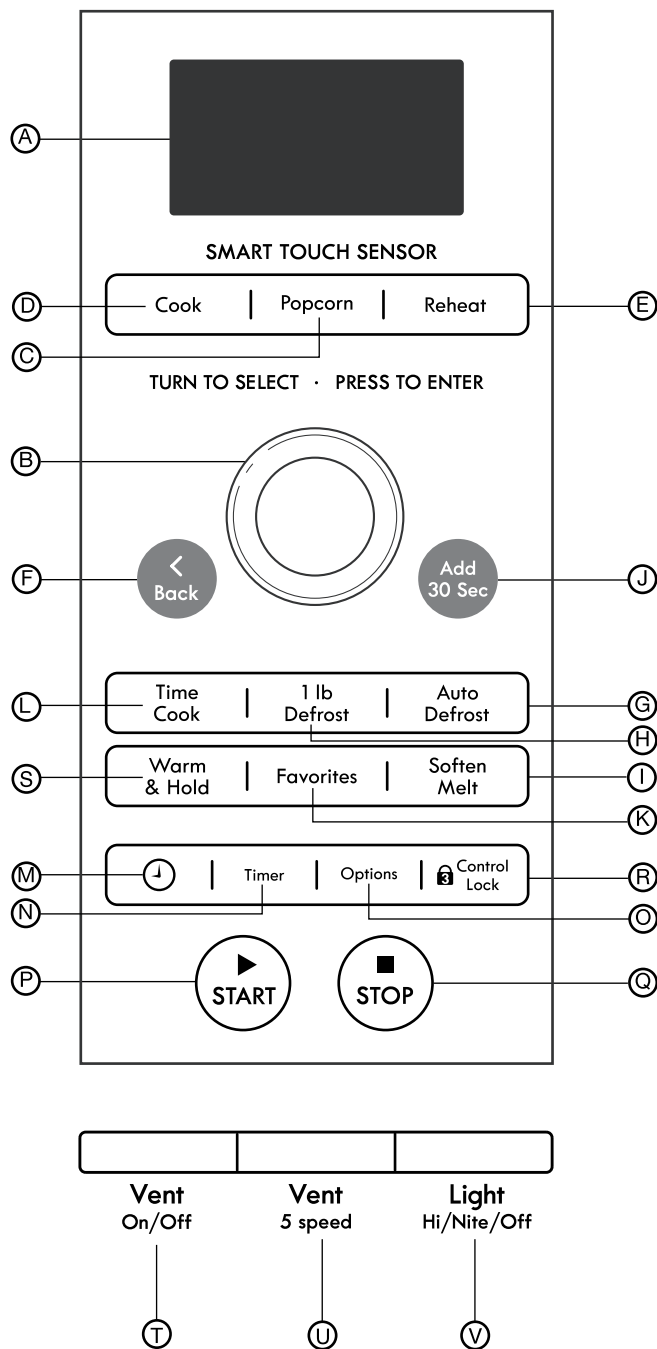

Figure 7

OVEN CONTROL PANEL



- C. Popcorn** Touch this pad to pop popcorn with the sensor feature. The oven's sensor will tell the oven how long to cook depending on the amount of humidity it detects from the popcorn.
- D. Cook** Touch this pad to cook microwavable foods without entering a cook time or power.
- E. Reheat** Touch this pad to reheat microwavable foods without entering a cook time or power.
- F. Back** This button can be used within menus to return to the previous screen.
- G. Auto Defrost** Touch this pad, followed by Number Pads, to thaw frozen meat by weight.
- H. 1 lb Defrost** Touch this pad to express defrost. "GROUND BEEF 1.0 LBS TOUCH START" will appear in the display.
- I. Soften/Melt** Touch this pad to soften ice cream, cream cheese, butter or frozen juice and melt chocolate, cheese, butter, or marshmallows.
- J. Add 30 Seconds** Touch this pad to cook for 30 seconds at 100% cook power, or to add extra seconds at the set cook power to your cooking cycle.
- K. Favorites** Touch this pad to recall a cooking instruction previously placed in memory.
- L. Time Cook** Touch this pad for manual control of cook time and power level.
- M. Clock** Touch this pad to enter the time of day.
- N. Timer** Touch this pad to set the kitchen timer.
- O. Options** Touch this pad to change the oven's default settings for sound, clock, display speed and defrost weight.
- P. Start** Touch this pad to start a function. If you open the door after the oven begins to cook, retouch Start.
- Q. Stop** Touch this pad to stop and cancel any oven function.
- R. Control Lock** Touch and hold this pad for three seconds to lock the control panel.
- S. Warm & Hold** Touch this pad to keep hot, cooked foods safely warm in your oven for up to 90 minutes.
- T. Vent On/Off** Touch this pad to turn the fan on/off.
- U. Vent 5 Speed** Touch this pad to choose one of five fan speeds.
- V. Light Hi/Nite/Off** Touch this pad to turn the light on high, night (low) or off.

A. Display Screen shows the time of day and cook mode when the microwave oven is not in use. During programming, it displays function menus for you to choose from, servings and weights for you to enter, preparation instructions, and cooking time/power settings for you to select. During a cooking cycle, it counts down the remaining time and prompts you to stir, turn food, etc., as necessary.

B. Touch Dial Control Use this dial to select oven functions, such as quantities of food and cooking times/powers.

How to Use

DIAL CONTROL

Faster, easier, better than ever before—
Just watch the display screen and choose what you want from the menus.

Touch function pad to:

- Select desired function. This must be done before the dial can be used.

Turn DIAL control to:

- Set clock/kitchen timer.
- Select options and choices.
- Set cook time and power.

Press DIAL control to:

- Enter a selection.
- Start cooking.

Touch STOP to:

- Stop any microwave function.

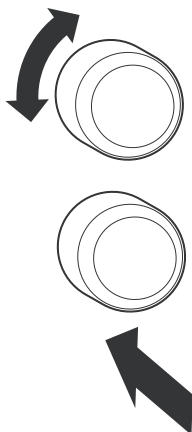

CLOCK

Example: To set the clock for 8:00 P.M.

Touch:

Display Shows:

1.  Touch the **CLOCK** pad.

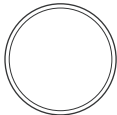
2.  Set the time of day by turning the dial and pressing for hours and then minutes.



3.  Turn the dial to select **PM** and press.

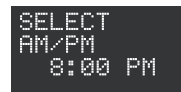

NOTE: You must set the clock before the microwave oven can be used.

FUNCTION SELECTIONS

Cook

- Casserole
- Eggs
- Fish & Seafood
- Frozen Entree
- Meat
- Pizza – Microwave
- Potatoes
- Poultry
- Rice & Pasta
- Vegetable – Canned
- Vegetable – Fresh
- Vegetable – Frozen

Reheat

- Beverage
- Casserole
- Dinner Plate
- Pizza Reheat
- Soup & Sauce

Auto Defrost

- Meat
- Poultry
- Fish
- Bread

Soften/Melt

- Melt
- Soften

Favorites

- Use Favorite Recipe
- Add Recipe
- Edit Recipe
- Delete Recipe

Options

- Auto Nite Lite (Auto Night Light)
- Clock On/Off
- Demo On/Off
- Lbs/Kg
- Reminder
- Scroll Speed
- Sound On?Of

TIMER

Your microwave oven can be used as a kitchen timer. You can set up to 99 minutes, 99 seconds.

Example: To set Kitchen Timer (3 minutes).

Touch:

Display Shows:

1. **Timer** Press the **TIMER** pad.



2.  Turn the dial to enter the time and press to set.



3.  Press the dial to start.



NOTE: To cancel the kitchen timer, press the **TIMER** pad. "TIMER CLEARED" appears in the display.

VENT

The **VENT** removes steam and other vapors from the cooking surface.

Touch:

Display Shows:

- Vent**
On/Off
Touch the **VENT ON/OFF** pad.
 
- Vent**
5 speed
Press the **VENT SPEED** pad to increase the vent speed from levels 1 to 5.
 
- Vent**
On/Off
Press the **VENT ON/OFF** pad to turn off.
 

NOTE: If the temperature gets too hot around the microwave oven, the fan in the vent hood will automatically turn on at the low setting to cool the oven. It may stay on up to an hour to cool the oven. When this occurs, **you cannot turn the vent fan off.** This can happen even though the microwave oven is not in use.



LIGHT

The pad on the bottom left of the control panel controls the cooktop light.

Example: To set the Lamp for HIGH.

Touch:

Display Shows:

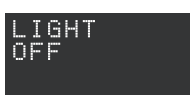
- Light**
Hi/Nite/Off
Touch the **LIGHT** pad to turn the light to **LIGHT HIGH**.
 
- Light**
Hi/Nite/Off
Touch the **LIGHT** pad to turn the light to **LIGHT NIGHT**.
 
- Light**
Hi/Nite/Off
Touch the **LIGHT** pad again to turn **OFF** the light.
 



ADD 30 SECONDS

This simplified time-saving pad lets you quickly set and start microwave cooking.

Example: To set for 2 minutes.

Touch:

Display Shows:

-  Touch the **ADD 30 SECONDS** pad four (4) times. The oven begins cooking immediately and the display shows time counting down.
 

NOTE: Each press of the **ADD 30 SECONDS** pad will add 30 seconds of cooking time, up to 99 minutes.

MANUAL COOK

Example: To cook food for 8 minutes 30 seconds at 70% power.

Touch:

1. Time Cook

Press the **TIME COOK** pad.

Display Shows:



2. TURN TO SELECT • PRESS TO ENTER

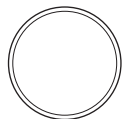

Turn the dial to select cook time and press enter. Turn the dial to select cook power.



- 3.



Press **START** or dial to begin cooking.

NOTE: Turn the dial to adjust cook time. The oven will beep when power is set to 0.

NOTE: Press **STOP** to pause. Press **START** to restart cooking.

TWO-STAGE COOKING

This oven can be programmed to automatically switch from one cooking power to another during a cooking cycle.

Example: To cook food for 3 minutes at 100% power (first stage) and for 7 minutes 30 seconds at 70% power (second stage).

Touch:

1. Time Cook

Press the **TIME COOK** pad.

Display Shows:

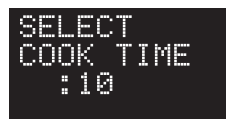

2. TURN TO SELECT • PRESS TO ENTER

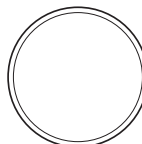

Turn the dial to select cook time and press to enter. Turn the dial to select cook power.



3. Time Cook

Press the **TIME COOK** pad to select second cook time. Turn the dial to select cook time and press to enter. Turn the dial to select cook power.



4. 

Press **START** or dial to begin cooking.

NOTE: Turn the dial to modify time.

NOTE: When the first cooking stage is complete, the second stage starts immediately.

NOTE: You may set the second stage to 0 power to establish a period of standing time within the oven.

COOKING GUIDE FOR POWER LEVELS

The nine power levels in addition to HIGH allow you to choose the best power level for the food you are cooking. Below are listed all the power levels, examples of foods best cooked at each level, and the amount of microwave power you are using.

POWER LEVEL	MICROWAVE OUTPUT	USE
10 (High)	100%	<ul style="list-style-type: none"> •Boil water •Cook ground beef •Make candy •Cook fresh fruits and vegetables •Cook fish and poultry •Preheat browning dish
9	90%	<ul style="list-style-type: none"> •Reheat meat slices quickly •Saute onions, celery, and green pepper
8	80%	<ul style="list-style-type: none"> •All reheating •Cook scrambled eggs
7	70%	<ul style="list-style-type: none"> •Cook breads and cereal products •Cook cheese dishes, veal •Cook cakes, muffins, brownies, cupcakes
6	60%	<ul style="list-style-type: none"> •Cook pasta
5	50%	<ul style="list-style-type: none"> •Cook meats, whole poultry •Cook custard •Cook whole chicken, turkey, spare ribs, rib roast, sirloin roast
4	40%	<ul style="list-style-type: none"> •Cook less tender cuts of meat •Reheat frozen convenience foods
3	30%	<ul style="list-style-type: none"> •Thaw meat, poultry, and seafood •Cook small quantities of food •Finish cooking casserole, stew, and some sauces
2	20%	<ul style="list-style-type: none"> •Soften butter and cream cheese •Heat small amounts of food
1	10%	<ul style="list-style-type: none"> •Soften ice cream •Raise yeast dough
0		<ul style="list-style-type: none"> •Standing time in oven

OPTIONS

The pad on the bottom left of the control panel controls the cooktop light.

FUNCTION	REMARK
Auto Night Light	set auto night light time
Clock On/Off	turn clock on/off
Demo On/Off	demo mode on/off
Lbs/Kg	change weight measurement
Reminder	set reminder time
Scroll Speed	adjust scroll speed to desired level
Sound On/Off	turn sound on/off

Example: To choose an option.

Touch: 1. Options **Display Shows:** Press the **OPTIONS** pad.

1. Options **Display Shows:**

```
+AUTO NITE
CLOCK ON/
DEMO ON/O
LBS/KG
+REMINDER
SCROLL
SOUND ON/
```

AUTO NIGHT LIGHT

Example: Set ON time to 11:00 PM and OFF time to 7:00 AM.

Touch: 1. Options **Display Shows:** Touch the **OPTIONS** pad.

1. Options **Display Shows:**

```
+AUTO NITE
CLOCK ON/
DEMO ON/O
```

2. **Display Shows:** Press the dial to select **AUTO NITE LITE.**

```
-AUTO NITE
+SET NITE
+REVIEW N
```

3. **Display Shows:** Press the dial to select **SET NITE LITE.** Turn the dial to select the ON times in hours. Press again for minutes. Press the dial again to select AM or PM. Repeat this to set the OFF time.

```
SELECT
ON TIME
00:00
[TURN] [OK]
```

4. **Display Shows:** Press the dial; the screen will briefly display the ON/OFF settings.

```
NITE LITE
ON 11:00PM
OFF 7:00AM
```

Example: To check night light setting.

Touch: 1. Options **Display Shows:** Touch the **OPTIONS** pad.

1. Options **Display Shows:**

```
+AUTO NITE
CLOCK ON/
DEMO ON/O
```

2. **Display Shows:** Press the dial to select **AUTO NITE LITE.**

```
-AUTO NITE
+SET NITE
+REVIEW N
```

3. **Display Shows:** Turn dial to select **REVIEW NITE LITE** and press to show current settings.

```
NITE LITE
ON 11:00PM
OFF 7:00AM
```

Example: To clear night light setting.

Touch: 1. Options **Display Shows:** Touch the **OPTIONS** pad.

1. Options **Display Shows:**

```
+AUTO NITE
CLOCK ON/
DEMO ON/O
```

2. **Display Shows:** Press the dial to select **AUTO NITE LITE.**

```
-AUTO NITE
+REVIEW N
+CLEAR NI
```

3. **Display Shows:** Turn the dial to select **CLEAR NITE LITE** and press to clear settings.

```
NITE LITE
IS CLEARED
```

CLOCK ON/OFF

Example: Turn clock on or off.

- | Touch: | Display Shows: |
|--|----------------|
| 1. Options
Touch the OPTIONS pad. | |
| 2. <small>TURN TO SELECT • PRESS TO ENTER</small>

Turn the dial to select CLOCK ON/OFF and press. | |
| 3. <small>TURN TO SELECT • PRESS TO ENTER</small>

Turn the dial to select ON or OFF and press to enter. | |

DEMO ON/OFF

Example: Turn demo mode on.

- | Touch: | Display Shows: |
|--|----------------|
| 1. Options
Touch the OPTIONS pad. | |
| 2. <small>TURN TO SELECT • PRESS TO ENTER</small>

Turn the dial to select DEMO ON/OFF and press. | |
| 3. <small>TURN TO SELECT • PRESS TO ENTER</small>

Turn the dial to select ON and press to enter. | |

LBS/KG

Example: Change weight measurement to LBS.

- | Touch: | Display Shows: |
|---|----------------|
| 1. Options
Touch the OPTIONS pad. | |
| 2. <small>TURN TO SELECT • PRESS TO ENTER</small>

Turn the dial to select LBS/KG and press. | |
| 3. <small>TURN TO SELECT • PRESS TO ENTER</small>

Turn the dial to select LBS and press to enter. | |

REMINDER

Example: Set a reminder for 8:45 AM.

- | Touch: | Display Shows: |
|---|----------------|
| 1. Options
Touch the OPTIONS pad. | |
| 2. <small>TURN TO SELECT • PRESS TO ENTER</small>

Turn the dial to select REMINDER and press. | |
| 3. <small>TURN TO SELECT • PRESS TO ENTER</small>

Press the dial to select SET REMINDER . Turn the dial to select the ON time in hours. Press again for minutes. Press the dial again to select AM or PM. | |
| 4. <small>TURN TO SELECT • PRESS TO ENTER</small>

Press the dial; the screen will briefly display the reminder setting. | |

Example: Check that the reminder is set.

- | Touch: | Display Shows: |
|--|----------------|
| 1. Options
Touch the OPTIONS pad. | |
| 2. <small>TURN TO SELECT • PRESS TO ENTER</small>

Turn the dial to select REMINDER and press. | |
| 3. <small>TURN TO SELECT • PRESS TO ENTER</small>

Turn the dial to select REVIEW REMINDER and press. The screen will briefly display the reminder setting. | |

REMINDER

Example: Clear reminder from memory.

Touch:

Display Shows:

- Options Touch the **OPTIONS** pad.
- TURN TO SELECT • PRESS TO ENTER Turn the dial to select **REMINDER** and press.
- TURN TO SELECT • PRESS TO ENTER Turn the dial to select **CLEAR REMINDER** and press to clear settings.

SCROLL SPEED

Example: Change scroll speed to fast.

Touch:

Display Shows:

- Options Touch the **OPTIONS** pad.
- TURN TO SELECT • PRESS TO ENTER Turn the dial to select **SCROLL SPEED** and press.
- TURN TO SELECT • PRESS TO ENTER Turn the dial to select **FAST** speed and press to enter.

SOUND ON/OFF

Example: Turn sound on or off.

Touch:

Display Shows:

- Options Touch the **OPTIONS** pad.
- TURN TO SELECT • PRESS TO ENTER Turn the dial to select **SOUND ON/OFF** and press.
- TURN TO SELECT • PRESS TO ENTER Turn the dial to select **OFF** and press to enter.

BACK



The **BACK** button can be used within menus to return to the previous screen.

Pressing the **BACK** pad will not pause or interrupt a cycle.

SOFTEN/MELT

The oven uses low power to melt or soften foods (butter, chocolate, marshmallows and cheese).

Example: To Melt 8 oz. Chocolate.

Touch:

Display Shows:

- Soften Melt Touch the **SOFTEN/MELT** pad.
- TURN TO SELECT • PRESS TO ENTER Turn the dial to select **MELT** and press.
- TURN TO SELECT • PRESS TO ENTER Turn the dial to select **BUTTER** and press. Turn the dial to enter the number of sticks.
- START Press **START** or dial to begin cooking.

CONTROL LOCK

You may lock the control panel to prevent the microwave oven from being started accidentally or used by children.

Example: To set the control lock.

Touch:

Display Shows:

- Control Lock Press and hold **CONTROL LOCK** for 3 seconds to lock.

FAVORITES

FAVORITES lets you recall one cooking instruction previously placed in memory and begin cooking quickly.

Example: To add a recipe (reheat a piece of pizza for 30 seconds).

Touch: **Display Shows:**

1. Favorites Press the **FAVORITES** pad. +USE FAVOR
+ADD RECIP
+EDIT RECI

2. TURN TO SELECT • PRESS TO ENTER
 To add a recipe, turn the dial to select **ADD RECIPE** and press. +USE FAVOR
+ADD RECIP
+EDIT RECI

3. TURN TO SELECT • PRESS TO ENTER
 Turn the dial to select **COOK TIME** and press. SELECT
COOK TIME
:10

4. TURN TO SELECT • PRESS TO ENTER
 Turn the dial to select cook power and press.

5. TURN TO SELECT • PRESS TO ENTER
 Enter the **FOOD NAME** by turning the dial to select the alphabet and press to enter each letter. SPELL
FOOD NAME

6.  Press **START**. PIZZA
RECIPE
ADDED

Example: To delete a memorized recipe (Pizza).

Touch: **Display Shows:**

1. Favorites To delete a recipe, press the **FAVORITES** pad. +USE FAVOR
+ADD RECIP
+EDIT RECI

2. TURN TO SELECT • PRESS TO ENTER
 Turn the dial to select **DELETE RECIPE** and press.

3. TURN TO SELECT • PRESS TO ENTER
 Turn the dial to select a recipe to delete (Pizza) and press. PIZZA
DELETED

Example: To use a memorized recipe (Pizza).

Touch: **Display Shows:**

1. Favorites To use a recipe, press the **FAVORITES** pad. +USE FAVOR
+ADD RECIP
+EDIT RECI

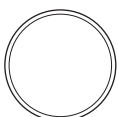
2. TURN TO SELECT • PRESS TO ENTER
 Turn the dial to **USE FAVORITE RECIPE** and press.

3. TURN TO SELECT • PRESS TO ENTER
 Turn the dial to select **RECIPE (Pizza)**. FAVORITES
PIZZA
:30 P=05

4.  Press **START** or dial to begin cooking.

Example: To edit a recipe (Pizza).

Touch: **Display Shows:**

1. Favorites To edit the recipe, press the **FAVORITES** pad. +USE FAVOR
+ADD RECIP
+EDIT RECI

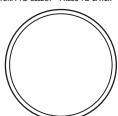
2. TURN TO SELECT • PRESS TO ENTER
 Turn the dial to select **EDIT RECIPE** and press.

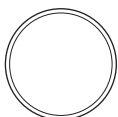
3. TURN TO SELECT • PRESS TO ENTER
 Select **PIZZA**. Turn the dial to change cook time or power (Pizza) and press to enter. FAVORITES
PIZZA
:30 P=05

4.  Press **START** or dial to enter. PIZZA
RECIPE
REVISED

USING SENSOR COOKING

SENSOR OPERATING INSTRUCTIONS

Sensor Cook allows you to cook most of your favorite foods without selecting cooking times and power levels. The display will indicate "Sensing" during the initial sensing period. The oven automatically determines the required cooking time for each food item. When the internal sensor detects a certain amount of humidity coming from the food, it will tell the oven how much longer to heat. The display will show the remaining heating time. For best results for cooking by Sensor, follow these recommendations.

- Food cooked with the sensor system should be at normal storage temperature.
- The glass tray (TURNABLE) and the outside of the container should be dry to ensure the best cooking results.
- Foods should always be covered loosely with microwavable plastic wrap, waxed paper or a lid.
- Do not open the door or touch the **STOP** key during the sensing time. When the sensing time is over, the oven beeps and the remaining cooking time will appear in the display window. At this time you can open the door to stir, turn or rearrange the food.

SENSOR COOKING GUIDE

Appropriate containers and coverings help ensure good Sensor cooking results.

- Always use microwavable containers and cover them with lids or vented plastic wrap.
- Never use tight-sealing plastic covers. They can prevent steam from escaping and cause food to overcook.
- Match the amount to the size of the container. Fill containers at least half full for best results.
- Be sure the outside of the cooking container and the inside of the microwave oven are dry before placing food in the oven. Beads of moisture turning into steam can mislead the sensor.

POPCORN

POPCORN lets you pop popcorn without needing to program times and power.

Example: To pop popcorn.

Touch:

1. Popcorn

Touch the **POPCORN** pad.

Display Shows:



- 2.



Press **START** or dial.

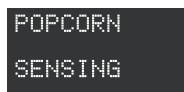

3. Wait for tones that signal the end of cooking time.

COOK

Using **COOK** lets you heat common microwave-prepared foods without needing to program cooking times and power levels.

Example: To cook Rice.

Touch:

1. Cook

Turn the dial to select **COOK** and press.

Display Shows:



- 2.

TURN TO SELECT • PRESS TO ENTER

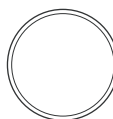

Turn the dial to select **POTATOES** and press.



- 3.

TURN TO SELECT • PRESS TO ENTER

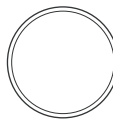

Turn the dial to select **WHITE POTATOES** and press to start cooking.



4. Wait for tones that signal the end of cooking time.

REHEAT

REHEAT lets you heat foods without needing to program cooking times and power levels.

Example: To reheat dinner plate.

Touch:

1. Reheat

Turn the dial to select **REHEAT** and press.

Display Shows:



- 2.

TURN TO SELECT • PRESS TO ENTER

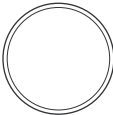

Turn the dial to select **DINNER PLATE** and press to start cooking.

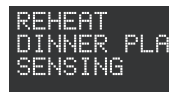

3. Wait for tones that signal the end of cooking time.

BACK



The **BACK** button can be used within menus to return to the previous screen.

Pressing the **BACK** pad will not pause or interrupt a cycle.

WARM & HOLD

You can safely keep hot, cooked food warm in your microwave oven for up to 90 minutes (about 1 hour, 30 minutes). You can use Warm & Hold by itself, or automatically follow a cooking cycle.

Example: To use the Warm & Hold.

Touch:

1. Warm & Hold

Press the **WARM & HOLD** pad.

Display Shows:



- 2.



Press dial or **START**

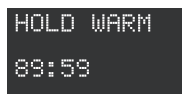

At the end of the warm & hold, **END** will be displayed and four tones will sound.

To make Warm & Hold automatically follow another cycle:

- **After entering cooking instructions**, touch Warm & Hold before touching START.
- **When the last cooking cycle is over**, you will hear two tones. “Hold” will come on while the oven continues to run.
- You can set Warm & Hold to follow Auto Defrost, Cook, or two-stage cooking.

NOTES:

- **Warm & Hold** operates for up to 90 minutes.
- **Opening** the oven door cancels Warm & Hold. Close the door and touch Warm & Hold, then touch START if additional Warm & Hold time is desired.
- **Food that is cooked covered** should also be covered during Warm & Hold.
- **Pastry items** (pies, turnovers, etc.) should be uncovered during Warm & Hold.
- **Complete meals** kept warm on a dinner plate should be covered during Warm & Hold.
- **Do not use** more than one complete Warm & Hold cycle (about 1 hour, 30 minutes). The quality of some foods will suffer with extended time.

AUTO DEFROST

Your microwave oven is preset with four defrost categories. Using **AUTO DEFROST** is the best way to defrost frozen foods.

Example: To defrost 1.2 lbs. of ground beef.

Touch: **Display Shows:**

1. Auto Defrost Press the **AUTO DEFROST** pad. 

2. TURN TO SELECT • PRESS TO ENTER Turn the dial to select **MEAT** and press. Turn the dial to enter the **WEIGHT**. 

3.  Press the dial or **START**.

4. Wait for tones that signal the end of cooking time.

WEIGHT CONVERSION CHART

To enter food weight in **DEFROST**, you must specify pounds and tenths of a pound. If the weight on the food package is in fractions of a pound, you can use the following chart to convert the weight to decimals.

Equivalent Weight	
OUNCES	DECIMAL WEIGHT
1.6	.10
3.2	.20
4.0	.25 One-Quarter Pound
4.8	.30
6.4	.40
8.0	.50 One-Half Pound
9.6	.60
11.2	.70
12.0	.75 Three-Quarters Pound
12.8	.80
14.4	.90
16.0	1.00 One Pound

NOTE: If between two decimal weights, choose the lower weight for the best defrosting results.

1 LB DEFROST

Example: To quickly defrost 1.0 lbs. of ground beef.

Touch: **Display Shows:**

1. 1 lb Defrost Press the **1 lb DEFROST** pad. 

2.  Press the dial or **START**.

3. Wait for tones that signal the end of cooking time.

DEFROSTING TIPS

- **When using Defrost**, the weight to be entered is the net weight in pounds and tenths of pounds (the weight of the food minus the container).
- **Use Defrost** only for raw food. Defrost gives best results when food to be thawed is a minimum of 0°F (taken directly from a true freezer). If food has been stored in a refrigerator-freezer that does not maintain a temperature of 5°F or below, always program a lower food weight (for a shorter defrosting time) to prevent cooking the food.
- **The shape of the package** affects how quickly food will defrost. Shallow packages will defrost more quickly than a deep block.
- **As food begins to defrost**, separate the pieces. Separated pieces defrost more easily.
- **Use small pieces of aluminum foil** to shield parts of food such as chicken wings, leg tips, fish tails, or areas that start to get warm. Make sure the foil does not touch the sides, top, or bottom of the oven. The foil can damage the oven lining.
- **For better results**, a preset standing time is included in the defrosting time.
- **Turn over** food during defrosting or standing time. Break apart and remove food as required.

DEFROST TABLE

NOTE: Meat of irregular shape and large, fatty cuts of meat should have the narrow or fatty areas shielded with foil at the beginning of the defrost sequence.

Meat settings

FOOD	SETTING	AT BEEP	SPECIAL INSTRUCTIONS
BEEF			
Ground Beef, Bulk	MEAT	Remove thawed portions with fork. Turn over. Return remainder to oven.	Do not defrost less than 1/4 lb. Freeze in ball shape.
Ground Beef, Patties	MEAT	Separate and rearrange.	Do not defrost less than 2 oz. patties. Depress center when freezing.
Round Steak	MEAT	Turn over. Cover warm areas with aluminum foil.	Place in a microwave safe dish.
Tenderloin Steak	MEAT	Turn over. Cover warm areas with aluminum foil.	Place in a microwave safe dish.
Stew Beef	MEAT	Remove thawed portions with fork. Separate remainder. Return remainder to oven.	Place in a microwave safe dish.
Pot Roast, Chuck Roast	MEAT	Turn over. Cover warm areas with aluminum foil.	Place in a microwave safe dish.
Rib Roast	MEAT	Turn over. Cover warm areas with aluminum foil.	Place in a microwave safe dish.
Rolled Rump Roast	MEAT	Turn over. Cover warm areas with aluminum foil.	Place in a microwave safe dish.
LAMB			
Cubes for Stew	MEAT	Remove thawed portions with fork. Return remainder to oven.	Place in a microwave safe dish.
Chops (1 inch thick)	MEAT	Separate and rearrange.	Place in a microwave safe dish.
PORK			
Chops (1/2 inch thick)	MEAT	Separate and rearrange.	Place in a microwave safe dish.
Hot Dogs	MEAT	Separate and rearrange.	Place in a microwave safe dish.
Spareribs Country-style Ribs	MEAT	Turn over. Cover warm areas with aluminum foil.	Place in a microwave safe dish.
Sausage, Links	MEAT	Separate and rearrange.	Place in a microwave safe dish.
Sausage, Bulk	MEAT	Remove thawed portions with fork. Turn over. Return remainder to oven.	Place in a microwave safe dish.
Loin Roast, Boneless	MEAT	Turn over. Cover warm areas with aluminum foil.	Place in a microwave safe dish.

DEFROST TABLE (Continued)

Poultry setting

FOOD	SETTING	AT BEEP	SPECIAL INSTRUCTIONS
CHICKEN Whole (up to 6 lbs) Cut-up	POULTRY	Turn over (finish defrosting breast side down). Cover warm areas with aluminum foil. Separate pieces and rearrange. Turn over. Cover warm areas with aluminum foil.	Place chicken breast-side up in a microwave-safe dish. Finish defrosting by immersing in cold water. Remove giblets when chicken is partially defrosted. Place in a microwave-safe dish. Finish defrosting by immersing in cold water.
CORNISH HENS Whole	POULTRY	Turn over. Cover warm areas with aluminum foil.	Place in a microwave-safe dish. Finish defrosting by immersing in cold water.
TURKEY Breast (up to 6 lbs)	POULTRY	Turn over. Cover warm areas with aluminum foil.	Place in a microwave-safe dish. Finish defrosting by immersing in cold water.

Fish setting

FOOD	SETTING	AT BEEP	SPECIAL INSTRUCTIONS
FISH Fillets Steaks Whole	FISH FISH FISH	Turn over. Separate fillets when partially thawed if possible. Separate and rearrange. Turn over.	Place in a microwave-safe dish. Carefully separate fillets under cold water. Place in a microwave-safe dish. Run cold water over to finish defrosting. Place in a microwave-safe dish. Cover head and tail with foil, do not let foil touch sides of microwave. Finish defrosting by immersing in cold water.
SHELLFISH Crab meat Lobster tails Shrimp Scallops	FISH FISH FISH FISH	Break apart. Turn over. Turn over and rearrange. Separate and rearrange. Separate and rearrange.	Place in a microwave-safe dish. Place in a microwave-safe dish. Place in a microwave-safe dish. Place in a microwave-safe dish.

NOTE: *Available weight is 0.1~6.0 lbs (0.1~2.7 Kg).

Care and Cleaning

To make sure your microwave oven looks good and works well for a long time, you should maintain it properly. For proper care, please follow these instructions carefully.

For interior surfaces: Wash often with warm, sudsy

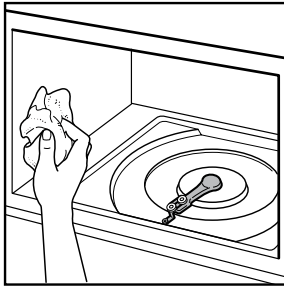

water and a sponge or soft cloth. Use only mild, nonabrasive soaps or a mild detergent. **Be sure to keep the areas clean where the door and oven frame touch when closed.** Wipe well with a clean cloth. Over time, stains can occur on the surfaces as the result of

food particles spattering during cooking. This is normal.

For stubborn soils: boil a cup of water in the oven for two to three minutes. Steam will soften the soil. To get rid of odors inside the oven, boil a cup of water with some lemon juice or vinegar in it.

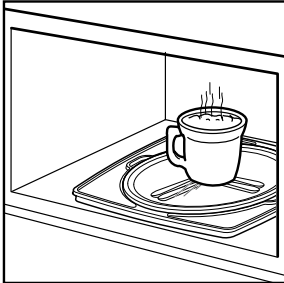

For exterior surfaces and control panel: Use a soft cloth with spray glass cleaner. Apply the spray glass cleaner to the soft cloth; do not spray directly on the oven.

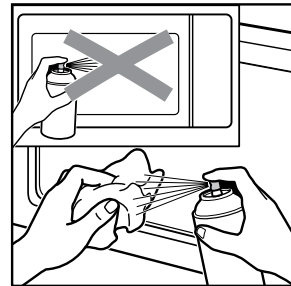

NOTE: Abrasive cleansers, steel wool pads, gritty wash cloths, some paper towels, etc., can damage the control panel and the interior and exterior oven surfaces.

To clean glass tray, rotating ring and guide tray:

Glass tray



Rotating ring



Guide tray



Wash in mild, sudsy water; for heavily soiled areas use a mild cleanser and scouring sponge. The glass tray, rotating ring, and guide tray are dishwasher safe.

REPLACING THE COOKTOP AND OVEN LIGHTS

The cooktop light

1. Unplug microwave oven or disconnect power.
2. Remove the bulb cover mounting screws.

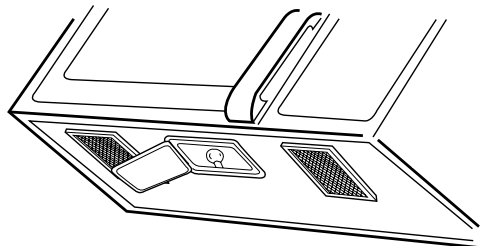

3. Replace the bulb.
4. Reinstall bulb cover with mounting screws.
5. Plug in microwave oven or reconnect power.

The oven light

1. Unplug microwave oven or disconnect power.
2. Remove the vent grille mounting screws.
3. Open the door. Tip the grille forward; then slide the grille to the left and pull out.

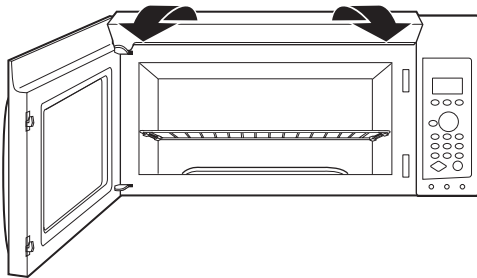

4. Remove the charcoal filter.

5. Remove the bulb holder by pushing the locking tab back slightly to disengage the tab from the bulb holder.

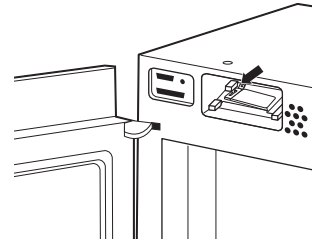

6. Lift up the bulb holder and slide it out of the compartment.

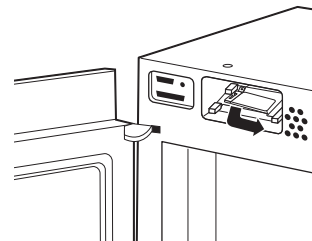

7. Replace the bulb.
8. Reinstall the bulb holder. Slide the bulb holder back into the compartment and press down firmly so the locking tab snaps into place.
9. Replace the charcoal filter.
10. Set the bottom of the grille in place, slide it to the right, and then snap the top in place. replace the mounting screws.

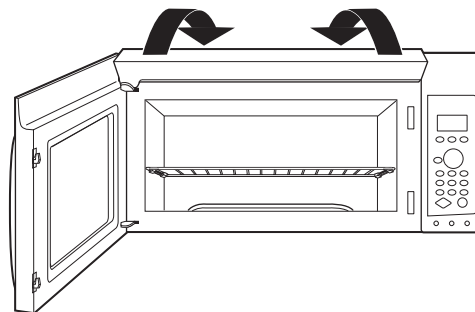

11. Plug in the microwave oven or reconnect power.

CARING FOR THE FILTERS

The grease filters should be removed and cleaned often, at least once a month.

NOTE: If your microwave hood combination is installed to recirculate air, the charcoal filter (Part No. 5230W1A0003A) is available from Sears by calling 1-800-4-MY-HOME®. The charcoal filter cannot be cleaned and should be replaced every 6 to 12 months.

Grease filters (Part No. 2B72705B):

1. Unplug microwave oven or disconnect power.
2. To remove grease filters, slide each filter to the side. Pull filters downward and push to the other side. The filter will drop out.

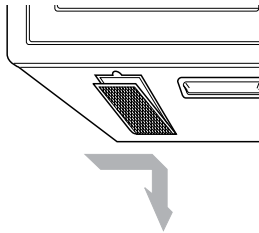

3. Soak grease filters in hot water and a mild detergent. Scrub and swish to remove embedded dirt and grease. Rinse well and shake to dry. Do not clean filters with ammonia or corrosive cleaning agents such as lye-based oven cleaners, or place them in a dishwasher. The filters will turn black or could be damaged.

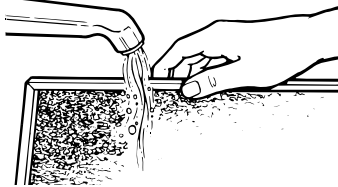

4. To replace grease filters, slide filter in the frame slot on one side of the opening. Push filter upward and push to the other side to lock into place.

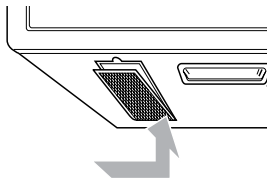

5. Plug in microwave oven or reconnect power.

Charcoal filter replacement:

If your oven is vented inside, the charcoal filter should be replaced every 6 to 12 months, and more often if necessary. The charcoal filter cannot be cleaned. Purchase a new charcoal filter from the nearest Sears Parts & Repair Service Center, or by calling 1-800-4-MY-HOME®.

1. Unplug microwave oven or disconnect power.
2. Remove the two vent grille mounting screws. Slide the vent grille slightly to the left.

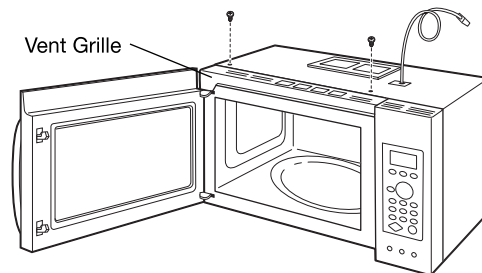

3. Tip the grille forward; then lift out to remove.
4. Remove the old filter.

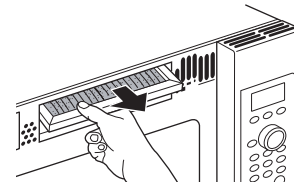

5. Slide a new charcoal filter into place. The filter should rest at the angle shown.

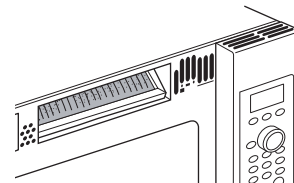

6. Push the vent grille into place. Slide the grille to the right until it snaps into place.
7. Replace the mounting screws.
8. Reconnect power or plug in microwave oven.

NOTE: Do not operate the hood without the grease filters in place.

Microwave Cooking Tips

Amount of food

- **If you increase or decrease** the amount of food you prepare, the time it takes to cook that food will also change. For example, if you double a recipe, add a little more than half the original cooking time. Check for doneness and, if necessary, add more time in small increments.

Starting temperature of food

- **The lower the temperature** of the food being put into the microwave oven, the longer it takes to cook. Food at room temperature will be reheated more quickly than food at refrigerator temperature.

Composition of food

- **Food with a lot of fat and sugar** will be heated faster than food containing a lot of water. Fat and sugar will also reach a higher temperature than water in the cooking process.
- **The more dense the food**, the longer it takes to heat. “Very dense” food like meat takes longer to heat than lighter, more porous food like sponge cakes.

Size and shape

- **Smaller pieces of food** will cook faster than larger pieces. Also, same-shaped pieces cook more evenly than different-shaped pieces.
- **With foods that have different thicknesses**, the thinner parts will cook faster than the thicker parts. Place the thinner parts of chicken wings and legs in the center of the dish.

Stirring, turning foods

- **Stirring and turning foods** spreads heat quickly to the center of the dish and avoids overcooking at the outer edges of the food.

Covering food

- **Cover** food to reduce splattering, shorten cooking times, and keep food moist.
- You can use any covering that lets microwaves pass through. See “How Your Microwave Hood Combination Works” on page 6 for materials that microwaves will pass through. If you are using the Sensor function, be sure to vent.

Releasing pressure in foods

- **Several foods** (for example: baked potatoes, sausages, egg yolks, and some fruits) are tightly covered by a skin or membrane. Steam can build up under the membrane during cooking, causing the food to burst. To relieve the pressure and to prevent bursting, **pierce** these foods before cooking with a fork, cocktail pick, or toothpick.

Using standing time

- **Always allow food to stand** either inside or outside the oven after the cooking or defrost period ends. Standing time allows the temperature to spread evenly throughout the food, improving cooking or defrosting results.
- **The length of the standing time** depends on how much food you are cooking and how dense it is. Sometimes it can be as short as the time it takes you to remove the food from the oven and take it to the serving table. However, with large, denser food items, the standing time may be as long as 10 minutes. For such longer periods, you may want to program a “0” power second stage of the cooking cycle for standing time inside the oven. See “Two-Stage Cooking.”

Arranging food

For best results, place food evenly on the plate. You can do this in several ways:

- **If you are cooking several items of the same food**, such as baked potatoes, place them in a ring pattern for uniform cooking.
- **When cooking foods of uneven shapes or thickness**, such as chicken breasts, place the smaller or thinner area of the food toward the center of the dish where it will be heated last.
- **Layer thin slices of meat** on top of each other.
- **When you cook or reheat whole fish**, score the skin – this prevents cracking.
- **Do not** let food or a container touch the top or sides of the oven. This will prevent possible arcing. Arcing is a spark that can cause damage to the oven interior.

Using aluminum foil

Metal containers should not be used in a microwave oven. There are, however, some exceptions. If you have purchased food which is prepackaged in an aluminum foil container, refer to the instructions on the package. When using aluminum foil containers, cooking times may be longer because microwaves will only penetrate the top of the food. If you use aluminum containers without package instructions, follow these guidelines:

- **Place** the container in a glass bowl and add some water so that it covers the bottom of the container, not more than 1/4 in. (.64 cm) high. This ensures even heating of the container bottom.
- **Always remove** the lid to avoid damage to the oven.
- **Use only** undamaged containers.
- **Do not use** containers taller than 3/4 in. (1.9 cm).
- **The container must be** at least half filled.
- **To avoid arcing**, there must be a minimum of 1/4 in. (.64 cm) between the aluminum container and the walls of the oven and also between two aluminum containers.
- **Always place** the container on the turntable.
- **Shield** with small pieces of aluminum foil the parts of food that may cook quickly, such as wing tips and leg ends of poultry.
- **Heating food** in aluminum foil containers usually takes up to double the time compared to reheating in plastic, glass, china, or paper containers. The heating time will vary depending upon the type of container you use.
- **Let food stand** for 2 to 3 minutes after heating so that heat is spread evenly throughout the container.

Cooking you should not do in your microwave oven

- **Do not** do canning of foods in the oven. Closed glass jars may explode, resulting in damage to the oven.
- **Do not** use the microwave oven to sterilize objects (baby bottles, etc.). It is difficult to keep the oven at the high temperature needed for sterilization.

Removing the rack

- When popping commercially packaged popcorn, **remove the rack from the oven**. Do not place the bag of microwave popcorn on the rack or under the rack..
- Popping microwave popcorn without removing the rack can cause fire or damage to your microwave oven.

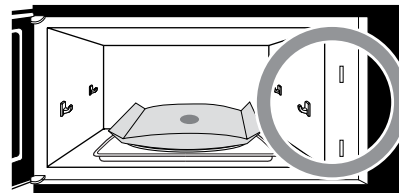
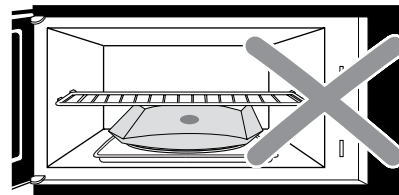
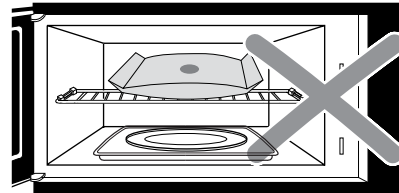

Questions and Answers

QUESTIONS	ANSWERS
Can I operate my microwave oven without the glass tray or move the glass tray over to hold a large dish?	No. If you remove or move the glass tray, you will get poor cooking results. Dishes used in your oven must fit on the glass or guide tray.
Can I use either metal or aluminum pans in my microwave oven?	You can use aluminum foil for shielding (use small, flat pieces), small skewers, and shallow foil trays (if tray is not taller than 3/4 in. [1.9 cm] deep and is filled with food to absorb microwave energy). Never allow metal to touch walls or door.
Is it normal for the guide tray to move in either direction?	Yes. The guide tray moves from side to side, depending on the rotation of the motor when the cooking cycle begins.
Sometimes the door of my microwave oven appears wavy. Is this normal?	This appearance is normal and does not affect the operation of your oven.
What are the humming noises that I hear when my microwave oven is operating?	You may hear the sound of the transformer when the magnetron tube cycles on.
Why does the dish become hot when I microwave food in it? I thought that this should not happen.	As the food becomes hot it will conduct the heat to the dish. Be prepared to use hot pads to remove food after cooking.
What does "standing time" mean?	"Standing time" means that after the timed cooking period ends, food should be allowed to stand either inside or outside of the oven to completely finish cooking. Outside oven standing time will allow the oven to be available for other use. For inside oven standing time, you can program a "0" power second stage of the cooking cycle. See : "Two - Stage Cooking."
Why does steam come out of the air exhaust vent?	Steam is normally produced during cooking. The microwave oven has been designed to vent this steam out the vents.
Can I pop popcorn in my microwave oven? How do I get the best results?	Yes. Pop packaged microwave popcorn following manufacturer's guidelines. Do not use regular paper bags. Do not repop unpopped kernels. Do not pop popcorn in glass cookware.
What is the maximum size dish I can place in the microwave oven?	Because of the large cavity and guide tray that moves side to side, you can use dishes up to 12 x 15 inches.

Troubleshooting

Most often, cooking problems are caused by little things you can find and fix without tools of any kind. Check the lists below and on the next page before calling for assistance or service. If you still need help, call Sears Service at 1-800-4-MY-HOME®.

MICROWAVE OVEN DOES NOT WORK

PROBLEM	CAUSE
Nothing works.	<ul style="list-style-type: none">• The power supply cord is not plugged into a grounded 3-prong outlet. (See the Electrical Requirements" section on page 5 and the "Electrical connection" section on Page 7.)• A household fuse has blown or a circuit breaker has tripped.• The electric company has had a power failure.
The microwave oven will not run.	<ul style="list-style-type: none">• You are using the oven as a timer. Press the Kitchen Timer pad, turn the dial to select "Turn off," and press to cancel the Kitchen Timer.• The door is not firmly closed and latched.• You did not touch START.• You did not follow directions exactly.• An operation that you set earlier is still running. Touch STOP/CLEAR to cancel that operation.

COOKING TIMES

PROBLEM	CAUSE
Food is not cooked enough.	<ul style="list-style-type: none">• The cook power is not at the recommended setting. Check the chart on Page 14.• The electric supply to your home or wall outlets is low or lower than normal. Your electric company can tell you if the line voltage is low. Your electrician or service technician can tell you if the outlet voltage is low.
The display shows a time counting down but the oven is not cooking.	<ul style="list-style-type: none">• The oven door is not closed completely.• You have set the controls as a kitchen timer. Press the Kitchen Timer pad, turn the dial to select "Turn off," and press to cancel the Kitchen Timer.

GLASS TRAY

PROBLEM	CAUSE
The glass tray will not move.	<ul style="list-style-type: none"> • The glass tray is not correctly in place. It should be correct-side up and sitting firmly on the center hub. • The support is not operating correctly. Remove the glass tray and restart the oven. If the hub still does not move, call Sears Service at 1-800-4-MY-HOME®. Cooking without the glass tray can give you poor results.

TONES

PROBLEM	CAUSE
You do not hear the programming or end-of-cycle tone.	<ul style="list-style-type: none"> • You have not entered the correct command.

VENT

PROBLEM	CAUSE
Vent fan comes on automatically.	<ul style="list-style-type: none"> • The vent fan will automatically turn on if it senses too much heat during cooking on the cooktop below.

If none of these items is causing your problem, call Sears Service at 1-800-4-MY-HOME®.

Get it fixed, at your home or ours!

Your Home

For troubleshooting, product manuals and home solutions advice:



www.managemylife.com

For repair - **in your home** - of **all** major brand appliances, lawn and garden equipment, or heating and cooling systems, **no matter who made it, no matter who sold it!**

For the replacement parts, accessories and owner's manuals that you need to do-it-yourself.

For Sears professional installation of home appliances and items like garage door openers and water heaters.

1-800-4-MY-HOME[®] (1-800-469-4663)

Call anytime, day or night (U.S.A. and Canada)

www.kenmore.com www.sears.com

Our Home

For repair of carry-in items like vacuums, lawn equipment, and electronics, call anytime for the location of your nearest

Sears Parts & Repair Service Center

1-800-488-1222 (U.S.A.) **1-800-469-4663** (Canada)

www.kenmore.com www.sears.com

To purchase a protection agreement on a product serviced by Sears:

1-800-827-6655 (U.S.A.) **1-800-361-6665** (Canada)

Para pedir servicio de reparación a domicilio, y para ordenar piezas:

1-888-SU-HOGAR[®]

(1-888-784-6427)

www.kenmore.com

Au Canada pour service en français:

1-800-LE-FOYER^{MC}

(1-800-533-6937)

www.sears.com

The Sears logo, featuring the word "Sears" in a stylized, bold, serif font with a shadow effect.

[®] Registered Trademark / TM Trademark of KCD IP, LLC in the United States, or Sears Brands, LLC in other countries

[®] Marca Registrada / TM Marca de Fábrica de KCD IP, LLC en Estados Unidos, o Sears Brands, LLC in otros países

^{MC} Marque de cinnerce / ^{MD} Marque déposée de Sear Brands, LLC.