

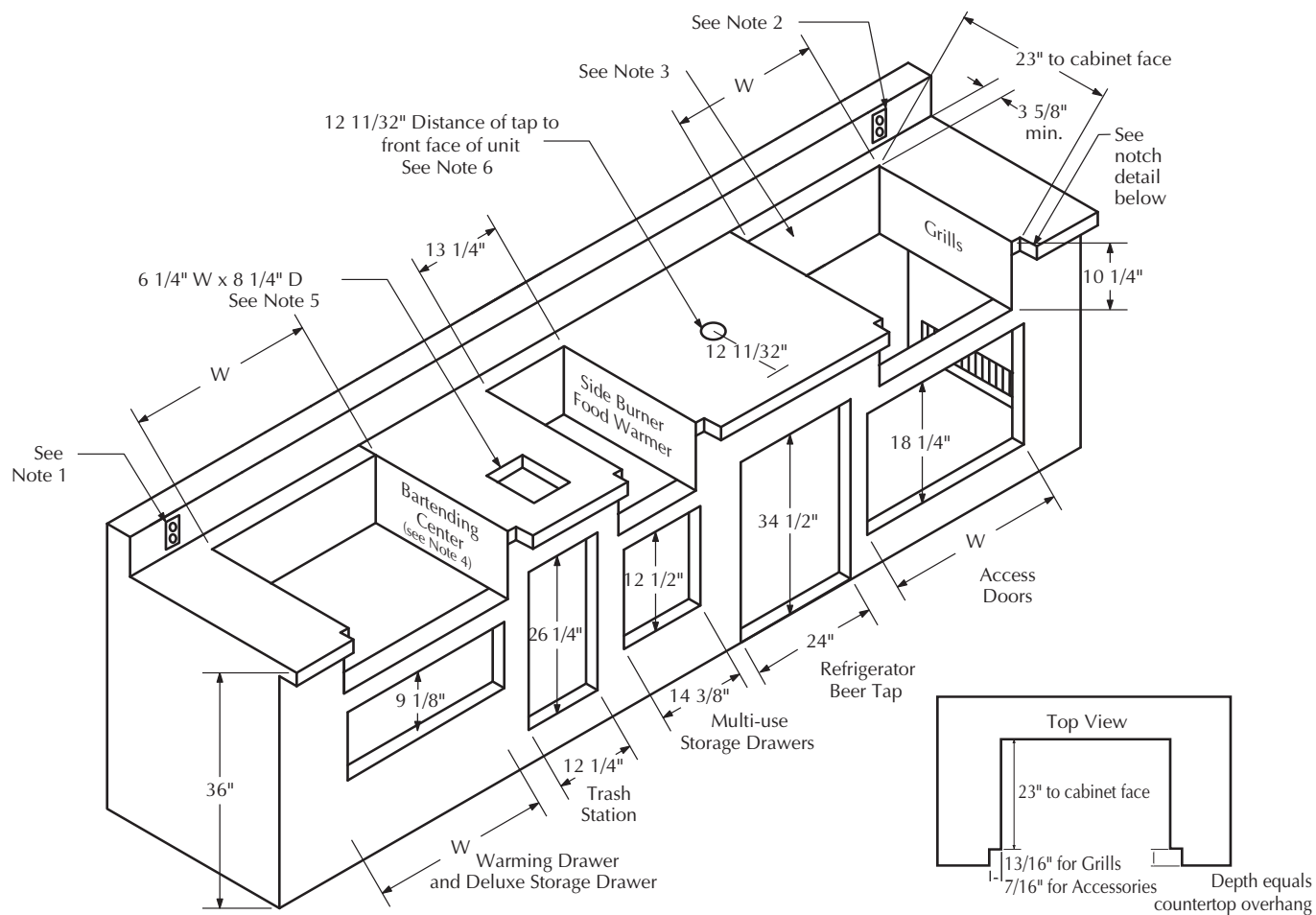

Luxury Outdoor Appliances

Built-in Cutout Dimensions



Built-in Cutout Dimensions

- Note 1:** Recommended electrical outlet for blender, appliance, etc.
- Note 2:** Recommended electrical outlet for rotisserie motor, light, etc.
- Note 3:** Combustible cabinets require insulated jackets for fire safety. Insulated jacket, depth = 24 1/2"; height = 11 1/4". Add 6 1/2" to grill cutout width.
- Note 4:** Ground drain recommended (models with sink require a single water supply connection).
- Note 5:** Prep/Waste Chute cutout is 6 1/4" W x 8 1/4" D. Front edge of cutout should be no more than 5" from front of island.
- Note 6:** Refrigerated base installations require 110v 15 amp electrical service.

Cut-out width (Dimension W) for built-in Vintage products

Grills

VBQ-30 (W= 28 1/2")
 VBQ-42 (W= 40 1/2")
 VBQ-56 (W= 54 1/2")

Bartending Centers

VDT-14 (W= 13 1/4")
 VDT-24 (W= 23 1/4")
 VDT-30 (W= 28 1/2")

Access Doors

VD-21 (W= 18 1/4")
 VD-30 (W= 27 1/4")
 VD-42 (W= 39 1/4")

Warming Drawer and Deluxe Storage Drawer

VRWO36SS (W= 34 5/8")
 VRWO30SS (W= 28 5/8")
 VRWO27SS (W= 25 5/8")

Specifications are subject to change without notice.