

This Owner's Manual is provided and hosted by [Appliance Factory Parts](http://www.appliancefactoryparts.com).

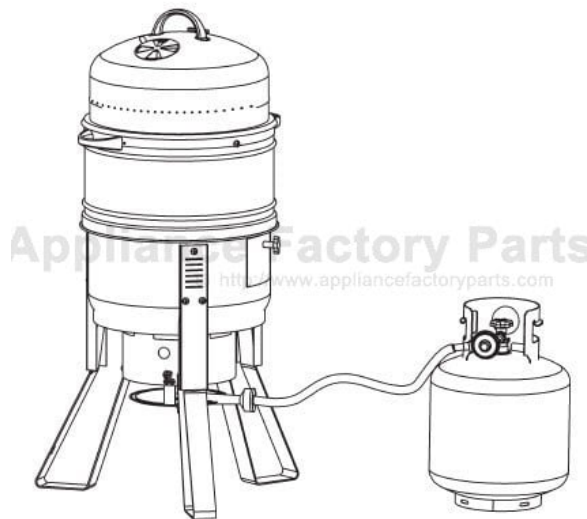

MASTERBUILT CM7P Owner's Manual

[Shop genuine replacement parts for MASTERBUILT
CM7P](#)



[Find Your MASTERBUILT Grill Parts - Select From 589 Models](#)

----- Manual continues below -----

Masterbuilt Manufacturing, Inc
A Georgia Company
450 Brown Avenue
Columbus, Georgia 31906
Customer Service 1-800-489-1581



DANGER

If you smell gas:

1. Shut off gas to the appliance.
2. Extinguish any open flame.
3. Open/remove door.
4. If odor continues, keep away from the appliance and immediately call your Fire Department.



DANGER

1. Never operate this appliance unattended.
2. Never operate this appliance within 10 feet (3m) of another gas cylinder.
3. Never operate this appliance within 25 feet (7.5m) of flammable liquids.
4. If fire should occur keep away from appliance and immediately call your fire department. Do not attempt to extinguish an oil/grease fire with water.

FAILURE TO FOLLOW THESE INSTRUCTIONS AND WARNINGS PROPERLY COULD RESULT IN FIRE OR EXPLOSION, WHICH COULD CAUSE PROPERTY DAMAGE, PERSONAL INJURY OR DEATH.



GENERAL WARNINGS AND SAFETY INFORMATION



- Unit is for outdoor use only.
- Never use inside enclosed areas such as patios, garages, buildings or tents.
- Never use inside recreational vehicles or on boats.
- Never operate unit under overhead construction such as roof coverings, carports, awnings, or overhangs.
- Never use unit as a heater.
- Maintain a minimum distance of 10ft (3m) from overhead construction, walls, rails or other structures.
- Keep a minimum 10ft (3m) clearance of all combustible materials such as wood, dry plants, grass, brush, paper, or canvas.
- Use unit on a level, non-combustible, stable surface such as dirt, concrete, brick or rock.
- Keep children and pets away from unit at all times. Do NOT allow children to use unit.
- Unit has an open flame. Keep hands, hair, and face away from burner flame. Do NOT lean over burner when lighting. Loose hair and clothing may catch fire.
- Allow unit to cool below 115°F (45°C) before moving or storing.
- Avoid bumping or impacting unit.
- This unit is HOT while in use and during cooling process. Wear protective gloves/mitts.
- Use of alcohol, prescription or non-prescription drugs may impair user's ability to properly assemble or safely operate unit.
- Never use glass, plastic or ceramic cookware in unit.
- Do NOT allow anyone to conduct activities around unit during or following its use until it has cooled.
- Accessory attachments not supplied by Masterbuilt Manufacturing, Inc. are not recommended.
- Never use unit for anything other than its intended use. This unit is NOT for commercial use.
- Use in accordance with local, state and federal fire codes.

SMOKING CHART

ITEM	SIZE	TEMP	CHARCOAL	WATER	WOOD CHIPS	COOKING TIME	INTERNAL TEMP
BEEF							
Pot Roast (arm, top, chuck, blade)	4 - 5 lbs (1.8-2.3kgs)	200°F (93°C)	7 - 8 lbs (3.2-3.6kgs)	3 - 4 qts (2.8-3.8l)	2 - 3 cups (0.56-0.83l)	3 - 4 hrs	140°F (60°C) Rare
							160°F (71°C) Medium
							170°F (77°C) Well Done
Brisket	3 - 4 lbs (1.4-1.8kgs)	200°F (93°C)	7 - 8 lbs (3.2-3.6kgs)	4 qts (3.8l)	3 cups (0.83l)	3 - 4.5 hrs	170°F (77°C) Well Done
PORK							
Loin Roast, bone in	3 - 4 lbs (1.4-1.8kgs)	200°F (93°C)	8 lbs (3.6kgs)	4 qts (3.8l)	2 cups (0.56l)	3.5 - 4.5 hrs	170°F (77°C) Well Done
	5 - 7 lbs (2.3-3.2kgs)		8 lbs (3.6kgs)	6 qts (5.7l)	3 cups (0.83l)	5 - 7 hrs	
Loin Roast, boneless	3 - 5 lbs (1.4-2.3kgs)	200°F (93°C)	10 lbs (4.6kgs)	4 - 5 qts (3.8-4.7l)	3 cups (0.83l)	3.5 - 5.5 hrs	170°F (77°C) Well Done
Spare Ribs	4 - 6 lbs (1.8-2.7kgs)	200°F (93°C)	8 - 10 lbs (3.6-4.6kgs)	4 qts (3.8l)	3 cups (0.83l)	2.5 - 3.5 hrs	Well done when meat pulls away from bone
	7 - 10 lbs (3.2-4.6kgs)		10 lbs (4.6kgs)	5 - 6 qts (4.7-5.7l)	3 cups (0.83l)	3.5 - 5 hrs	
POULTRY							
Chicken- 2 whole	2 - 3 lbs ea (0.9-1.4kgs)	200°F (93°C)	5 - 7 lbs (2.3-3.2kgs)	3 - 4 qts (2.8-3.8l)	2 cups (0.56l)	2.5 - 3.5 hrs	180°F (82°C) (Leg moves easily in joint)
Turkey	8 - 10 lbs (3.6-4.6kgs)	200°F (93°C)	8 lbs (3.6kgs)	5 qts (4.7l)	3 cups (0.83l)	4 - 6 hrs	185°F (85°C) (Leg moves easily in joint)
	11 - 13 lbs (5.0-5.9kgs)		8 - 10 lbs (3.6-4.6kgs)	6 qts (5.7l)	3 cups (0.83l)	6 - 7.5 hrs	
SEAFOOD							
Salmon	6 - 7 lbs (2.7-3.2kgs)	200°F (93°C)	10 lbs (4.6kgs)	5 - 6 qts (4.7-5.7l)	3 cups (0.83l)	4 - 6.5 hrs	Flesh white, flakes when forked
Fish Fillets	Full Grate	200°F (93°C)	5 lbs (2.3kgs)	3 qts (2.8l)	1 - 2 cups (0.28-0.56l)	1.5 - 2.5 hrs	
Shrimp, Clams, Crab Legs	Full Grate	200°F (93°C)	5 lbs (2.3kgs)	3 qts (2.8l)	1 - 2 cups (0.28-0.56l)	1 - 2 hrs	Shrimp pink Shells open
WILD GAME							
Quail, Dove etc.	12 - 16 birds	200°F (93°C)	7 - 10 lbs (3.2-4.6kgs)	4 qts (3.8l)	2 - 3 cups (0.56-0.83l)	2 - 4 hrs	Leg moves easily in joint
Pheasant, Duck, etc.	5 - 7 lbs (2.3-3.2kgs)	200°F (93°C)	8 - 10 lbs (3.6-4.6kgs)	4 - 5 qts (3.8-4.7l)	2 - 3 cups (0.56-0.83l)	4 - 5 hrs	180-185°F (82-85°C) Well Done



COOKING WITH OIL/GREASE WARNINGS



- All food products **MUST** be completely thawed and towel dried to remove excess water and ice. If not completely thawed and dried food may cause a boil over when placed into **HOT** oil, causing a fire and severe burns.
- Never overfill cooking vessel with cooking liquid. Follow instructions in this manual for establishing proper liquid levels.
- Never drop food or accessories into hot liquids.
- Be careful when removing food, liquid is hot and may cause burns.
- Use care when removing basket from cooking vessel, avoid pulling pot off cooker stand.
- Never heat oil above 400°F (200°C). If temperature exceeds 400°F (200°C) turn burner or gas supply **OFF**. Temperature must decrease to 350°F (177°C) then relight burner following burner lighting steps. If covered, do **NOT** remove cover(lid).
- When cooking with oil/grease, thermometer provided with unit must be used. See “Thermometer Safety Check and Usage” section in this manual for proper installation and use of thermometer.
- Do **NOT** leave unit unattended while heating liquid or cooling liquid after use. Liquid remains at scalding temperatures long after cooking has ended. Allow liquid to cool below 115°F (45°C) before cleaning and storing.
- In the event of rain, snow, hail, sleet or other form of precipitation when cooking with oil, cover cooking vessel and immediately turn off burner and gas supply. **DO NOT MOVE** cooker stand or cooking vessel.
- When cooking with oil/grease have BC or ABC type fire extinguisher readily accessible.

SHOULD OIL/GREASE FIRE OCCUR:

- Do **NOT** attempt to extinguish an oil/grease fire with water, **IMMEDIATELY** call your Fire Department. Personal safety is a priority.
- Type BC or ABC dry chemical fire extinguisher may, in some circumstances, contain fire. You may also be able to smother fire using dirt, sand or baking soda.
- If fire occurs **INSIDE POT** follow these steps-
 1. Turn off gas supply.
 2. Wearing protective glove, take pot lid and cover pot.
- If fire occurs **OUTSIDE POT**, follow these steps-
 1. Call Fire Department.
 2. Attempt to extinguish fire using BC or ABC type fire extinguisher.
 3. Turn off gas supply if possible.



WARNING



- Do **NOT** allow hose to come in contact with unit. **HOT** surfaces may damage hose causing leaks or fire.
- If oil starts to smoke **TURN BURNER OFF**. This means oil has exceeded 400°F(200°C) and will catch fire. Allow oil to cool below 400°F(200°C) before relighting burner.
- When cooking with oil **ALWAYS** turn burner **OFF** before lowering food into oil. Relight burner after food is submerged.

DO NOT TURN BURNER TO LOW SETTING TO KEEP OIL/GREASE HOT FOR LATER USE. TEMPERATURE OF OIL/GREASE WILL CONTINUE TO RISE AND WILL CATCH FIRE.

GRILL/SMOKER RECIPES

Grilling Recipes

Caribbean Chicken

8 pieces of chicken
1 tsp salt
1 1/2 tsp dried oregano
1/4 tsp paprika
1 tbs lemon or lime juice
1 small onion, minced
1 garlic clove, peeled
1/3 cup ketchup
1/3 cup cider vinegar

Mash salt with peeled garlic to make a paste. Work in 1/2 tsp of oregano, then paprika and lemon juice. Rub mixture over chicken. Put chicken on grill rack over hot coals. Turn chicken every 7 - 8 minutes. Combine ketchup, vinegar and remaining oregano. Simmer 15 minutes. When chicken is done, brush on chicken and grill an additional 5 minutes. Place chicken on warm platter and serve remaining mixture as sauce. Fried plantain, grill-baked bananas or saffron rice are good sides.

Grilled Flank Steak

1 1/2 lbs flank steak
1/4 cup worcestershire sauce
1/3 cup soy sauce
1 tsp ground ginger(dried or fresh)
Juice from 1 lemon

Combine sauces, ginger and lemon to make marinade. Place steak in shallow, glass casserole dish and pour marinade over meat. Marinate 3 hours. Grill 3-4 minutes per side. Slice diagonally and serve.

Smoking Recipes

Smoked Ham

1 10-lb pre-cooked ham
1/4 cup crushed pineapple
1/2 cup honey
2 tablespoons soy sauce

Combine pineapple, honey and soy sauce together. This is the basting mixture. Remove fat from ham. Score top of ham 1/4" deep. Put water bowl under middle grill rack. Do NOT add any liquid to bowl, this is a dry smoke recipe. Place ham on middle rack with scored side up. Place 2 - 3 wood chunks on charcoal or in flame disk bowl. Baste top of ham every hour with mixture. Cook 4 hours or until inside of ham is 140°F.

Smoked Turkey

6-8 lbs turkey
2 cups hickory or apple wood chips

Soak wood chips in water for at least one hour. This helps wood to smolder and smoke rather than burn up. Rinse turkey and dry well. Fold wings close to body and skewer. Close both end openings with skewers and tie legs tightly together. Secure with holding forks. Place water bowl under grill rack being used. Put turkey on grill rack over a low, indirect heat. Throw 1/2 of drained wood chips on hot coals and keep other half to be used as needed. Cook for approximately 2 1/2 hours. Internal temperature should be 185°F and leg should move easily in joint when done. Be sure to keep lid down and smoke in. Let turkey cool 10 minutes before carving.

SOAPY WATER TEST WARNINGS & PROCEDURES

Warnings:

- Soapy Water Test **MUST** be performed each time gas cylinder is connected to burner/hose and/or each time it is used.
- Soapy Water Test **MUST** be performed outdoors in well ventilated area.
- When performing Soapy Water Test keep smoker away from open flames, sparks or lit cigarettes.
- Smoker is designed to work with propane gas only. This product will **NOT** operate with natural gas.
- Never use an open flame to test for gas leaks.

Preparation:

- Remove any cookware/smoker from cooker stand.
- Make sure regulator and gas cylinder valve is turned to **OFF** position.
- Prepare soapy water solution: (1) part dish washing liquid (or more if desired), (3) parts water.
- Apply soapy water solution to gas cylinder valve, regulator and hose length up to burner.

APPLY SOLUTION TO GAS
CYLINDER VALVE.

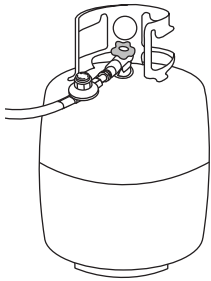

APPLY SOLUTION TO HOSE
REGULATOR AND THE FULL LENGTH OF
THE HOSE.

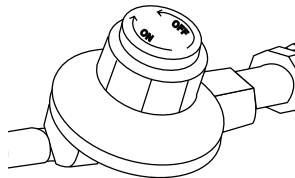

APPLY SOLUTION TO UNDERNEATH CONTROL PANEL
WHERE BURNER AND HOSE ARE CONNECTED.
(SMOKER SHOWN ON BACK FOR CLARITY ONLY)

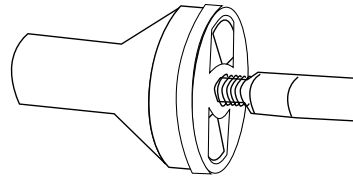

FAILED TEST WILL PRESENT
BUBBLES AS SHOWN BELOW

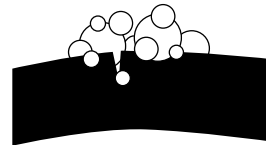

Testing Gas Valve:

- Turn gas cylinder valve **ON** and watch for bubbles. **DO NOT LEAVE GAS ON MORE THAN 12 SECONDS.** If bubbles appear, stop, turn gas cylinder **OFF** and retighten fitting. Repeat test.

Testing Regulator and Hose:

- **AFTER** gas cylinder valve has passed Soapy Water Test, turn gas cylinder valve **ON**, open regulator control valve one full turn and check for bubbles at valve location, along full length of hose and at burner connection. **DO NOT LEAVE GAS ON MORE THAN 12 SECONDS.** If bubbles appear, stop, turn regulator valve **OFF**, turn gas cylinder **OFF** and retighten the connection that is leaking gas. If hose is source of leak, **STOP**, do not use unit. Hose must be replaced.
- When test is complete, and there are no leaks, wait a minimum of 5 minutes for gas fumes to diminish before lighting cooker.

DURING ANY PORTION OF SOAPY WATER TEST IF BUBBLES CONTINUE TO APPEAR, STOP, DO NOT USE UNIT. CONTACT LOCAL PROPANE DEALER OR MASTERBUILT CUSTOMER SERVICE 1-800-489-1581.

Note: Use 20LB (9kgs) gas cylinder or smaller that has a protective collar with this unit. Cylinder **NOT** included with this unit.

BURNER MAINTENANCE

Cast Iron Burner Flame is Yellow or No Flame?

If burner flame is yellow, blows out frequently, does not light or flame is inside venturi then burner venturi needs to be checked for obstructions. Dirt doobers, spiders and other insects build nests inside burner venturi blocking air and gas flow. KEEP AIR SHUTTER CLOSED AFTER EACH USE.

How to clean burner assembly:

1. Remove hose from burner using adjustable wrench.
2. Insert small rod in opening of burner where hose was attached. This should breakup any obstructions.
3. Hold burner up to light and look for other obstructions.
4. If burner has not been cleared then flush with water. Make sure burner is completely dry before using.
5. Once burner has been cleared reassemble burner.

**KEEP BURNER VENTURI FREE OF OBSTRUCTIONS
OR DAMAGE TO HOSE ASSEMBLY MAY OCCUR.**

COOKING TIPS AND WOOD SMOKING GUIDE

Cooking in Cooler/Higher Climates

When outside temperature is cooler than 65°F (18°C) and/or altitude is above 3,500 feet (1067m), additional cooking time may be required. To insure that meat is completely cooked use a meat thermometer to test internal temperature.

Lifting Smoker Lid during cooking process may extend cooking time due to heat loss.

Using One Grill Rack

When using only one grill rack, use upper grill rack for better results.

Using Two Grill Racks

When using both grill racks, place food requiring least cooking time on top grill rack.

WOOD SMOKING GUIDE FOR MEATS

WOOD FLAVOR	POULTRY	FISH	HAM	BEEF	PORK	LAMB
Hickory Pungent, smoky, bacon-like flavor	✓	✓	✓	✓	✓	
Mesquite Sweet and delicate flavor	✓			✓		✓
Alder Delicate, wood smoke flavor	✓	✓			✓	
Pecan Bold and hearty flavor	✓	✓			✓	
Maple Sweet, subtle flavor	✓				✓	
Apple Sweet, delicate flavor	✓	✓			✓	
Cherry Sweet, delicate flavor	✓				✓	



CAUTIONS WHEN USING POTS WITH SMOKER



POT SIZE AND PLACEMENT

**I
N
C
O
R
R
E
C
T**

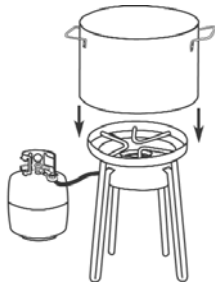

**C
O
R
R
E
C
T**

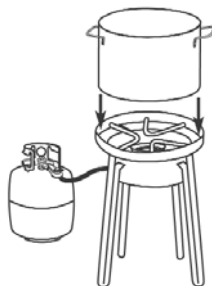

- Do NOT use cooking pot or vessel larger than 30qts. Cooking pot or vessel MUST fit inside cooker security ring.
- NEVER place an empty cooking vessel on unit while in operation.

POTS WITH BASKETS AND FRYING RACKS

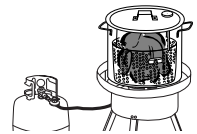
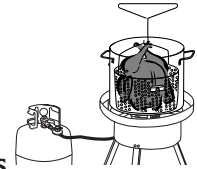
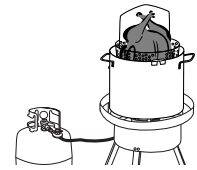
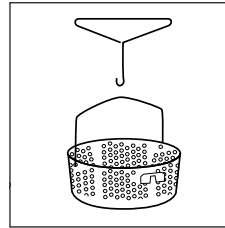

- Do NOT overfill pot with oil or water. Larger pots have a fill line mark. Smaller pots may not be marked. See "How to Use Cooker" section in this manual.
- After filling pot, place food in basket or on rack. Slowly lower into oil or water using lifting hook. Wear protective gloves. Cover with lid.
- When food is ready to remove, turn burner to OFF position. Wear protective gloves and remove lid. Use lifting hook to pull basket/rack up slowly.

INSTALLING FRY THERMOMETER

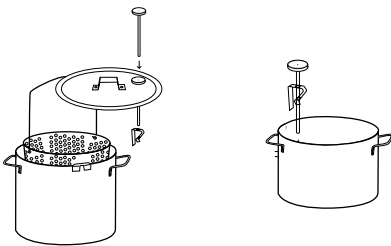

- Place stem of thermometer through hole in lid.
- Slide clip onto thermometer stem.
- If no lid, clip thermometer to side of cooking pot.

THERMOMETER SAFETY CHECK AND USAGE

- Before each use place thermometer stem in boiling water. Make sure it registers 212°F (100°C) +/- 20°F (10°C) If it does not, contact Masterbuilt Customer Service at 1-800-489-1581 to order a replacement.
- Do NOT let thermometer pierce food when lowering into pot. This will give a false reading.

SIDE SHELF ASSEMBLY

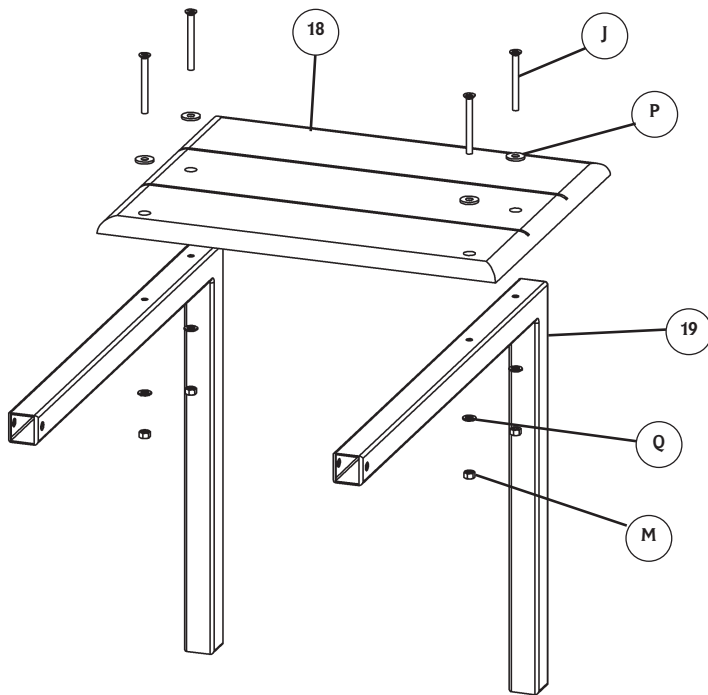

STEP 1.

Place wood shelf (18) on top of side shelf legs (19) as shown.

Attach using phillips head screws (J), flat washers (P), lock washers (Q) and hex nuts (M).

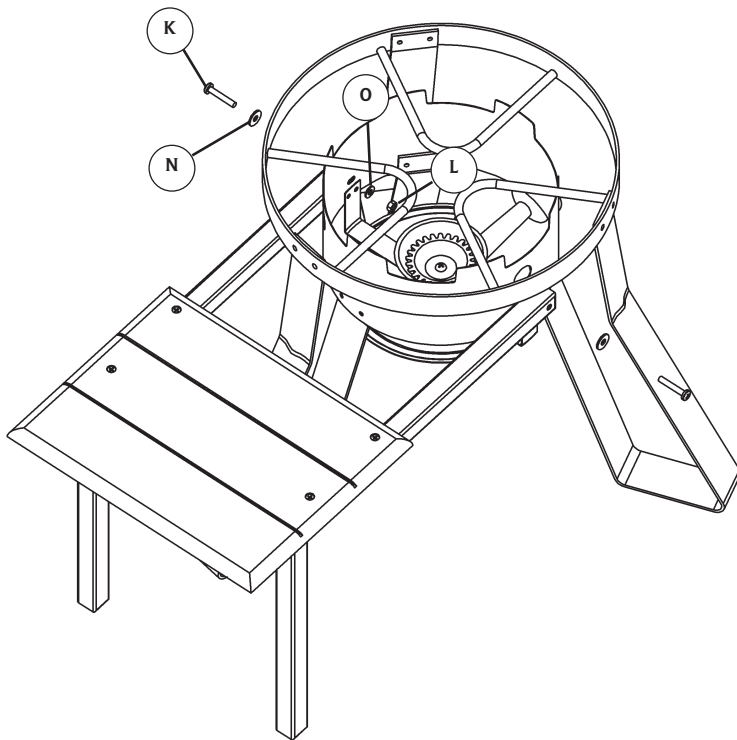

Step 2

Align side shelf legs to cooker head and attach as shown using phillips head screws (K), flat washers (N), lock washers (O) and hex nuts (L).

HARDWARE LIST



(A)
M6x1x10
Phillips Head
Flange Screw
qty - 12

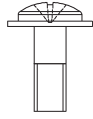

(B)
M6x1x16
Phillips Head
Flange Screw
qty - 16



(C)
M5x1x10
Phillips Head
Screw
qty - 3

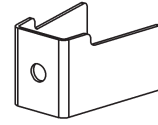

(D)
Grill Bracket
qty - 6

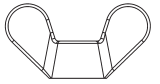

(E)
6MM
Wing Nut
qty - 12

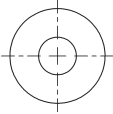

(F)
M6
Flat Washer
qty - 6



(G)
M6
Lock Washer
qty - 6



(H)
M5
Hex Nut
qty - 3



(I)
M5
Lock Washer
qty - 3

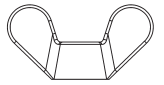

(J)
8MM
Wing Nut
qty - 1

SIDE SHELF HARDWARE

(SIDE SHELF NOT INCLUDED IN ALL MODELS. CHECK UNIT PACKAGING FOR PRODUCT DETAILS.)



(J)
M5x0.8x50
Phillips Head
Screw
qty - 4



(K)
M6x1x35
Phillips Head
Screw
qty - 2



(L)
M6
Hex Nut
qty - 2



(M)
M5
Hex Nut
qty - 4

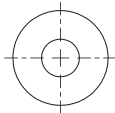

(N)
M6
Flat Washer
qty - 2



(O)
M6
Lock Washer
qty - 2

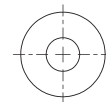

(P)
M5
Flat Washer
qty - 4



(Q)
M5
Lock Washer
qty - 4

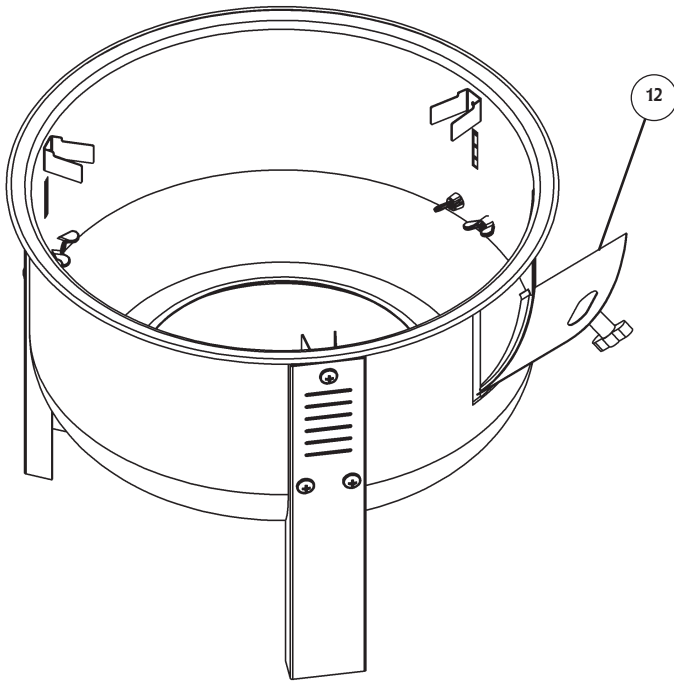

STEP 5.

Place bottom flange of charcoal access door (12) inside door opening in base pan. Close access door and turn knob to secure. To open door turn knob until door releases.

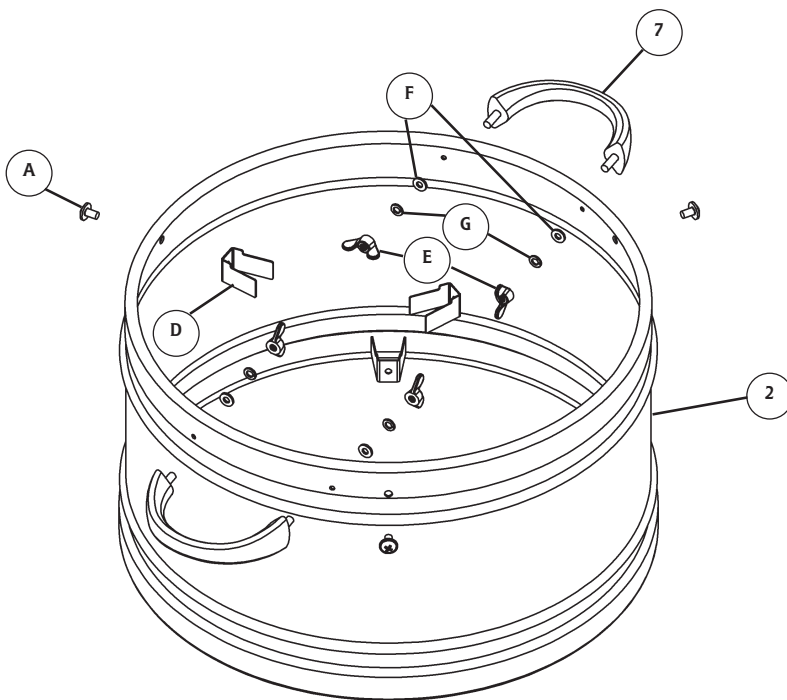

STEP 6a.

Use handle's (7) pre-threaded bolt, flat washer (F), lock washer (G) and wing nut (E) to mount handle to smoker body (2) as shown. Repeat on other side.

STEP 6b.

Align grill brackets (D) with smoker body holes and secure with phillips head flange screw (A).

Before assembly read instructions carefully.

Tools needed for assembly:

Phillips Head Screwdriver
Adjustable Wrench

Assemble unit on a clean, flat surface.

Do not tighten screws all the way. Cooker stand legs may need to be adjusted during assembly.

STEP 1.

Attach cooker stand legs (5) to cooker head (4) using phillips head flange screws (B) as shown.

Now tighten all screws.

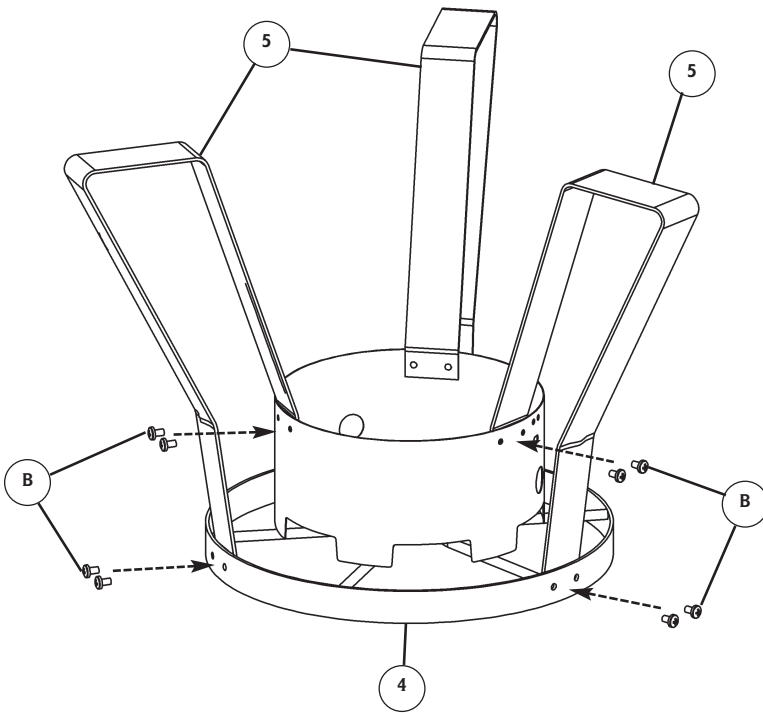

STEP 2.

Burner Hose Assembly:

Place air shutter on burner (13) venturi.

Slide small end of spring onto end of hose (20).

Thread end of hose into burner clockwise to tighten. Do NOT overtighten.

