

This Owner's Manual is provided and hosted by [Appliance Factory Parts](http://www.appliancefactoryparts.com).



# MASTERBUILT ESMMC Owner's Manual

[Shop genuine replacement parts for MASTERBUILT ESMMC](#)

- PARTS LIST:**
1. 1 Air Damper
  2. 1 Round Handle
  3. Heat Indicator
  4. Dome Lid
  5. 2 Grill Racks
  6. 2 "U" Shaped Handles
  7. Smoker Body
  8. 6 Grill Rack Brackets (Not Shown)
  9. 3 Legs
  10. 1 Water Bowl
  11. Smoker Access Door (Not Shown)
  12. Base Pan
- Additional Parts For:**
- Charcoal Smoker 1 -12 and A. Wood and Charcoal Bowl
  - Electric Smoker 1 -12 and B. 110 Volt Electric Element and Element Disk

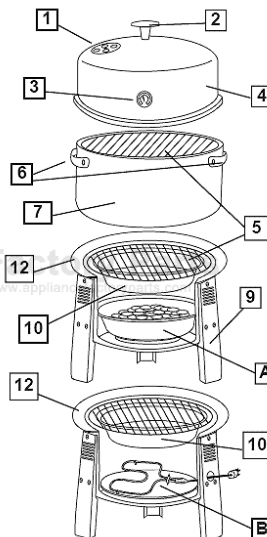

[Find Your MASTERBUILT Grill Parts - Select From 589 Models](#)

----- Manual continues below -----

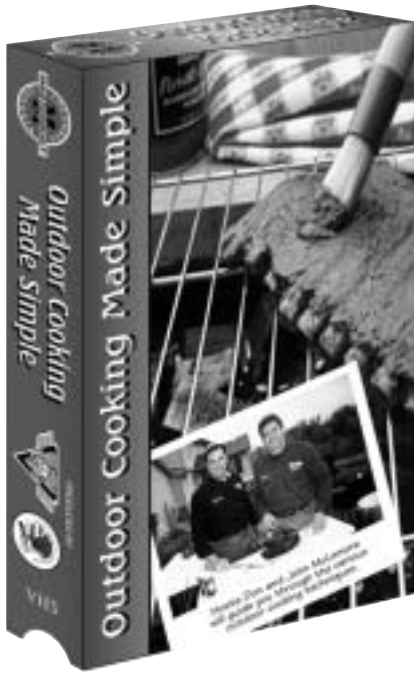

## Free Video Offer

### “Outdoor Cooking Made Simple”

From European and Southern style cooking to Louisiana Cajun and Midwest flavors, hosts Don and John McLemore guide viewers, step by step, through the world of smoking, grilling, frying and boiling. Let more than 20 recipes, filmed on the ESPN North American Outdoors show, tempt your taste buds and open up a world of rich flavor and awesome eating.

#### Shipping

Within continental United States.....\$5.95

In Alaska, Hawaii and Canada.....Call 800 489-1581 EXT. 101 for rates

Yes, I would like the free video and have included my payment for shipping and handling charges.

Call 800 489-1581 EXT. 101 for Visa or Mastercard orders, or send check or money order to: **MASTERBUILT Mfg., Inc.**  
(See address below.)



Send in an envelope to:  
Masterbuilt Mfg. Inc.,  
Attn: Warranty Dept.  
450 Brown Ave., Columbus, GA 31906

For Models: MC, EMC, SMMC & ESMMC 8/31/98

# MASTERBUILT

CHARCOAL and ELECTRIC SMOKERS  
ASSEMBLY AND OPERATION  
WARNING AND SAFETY

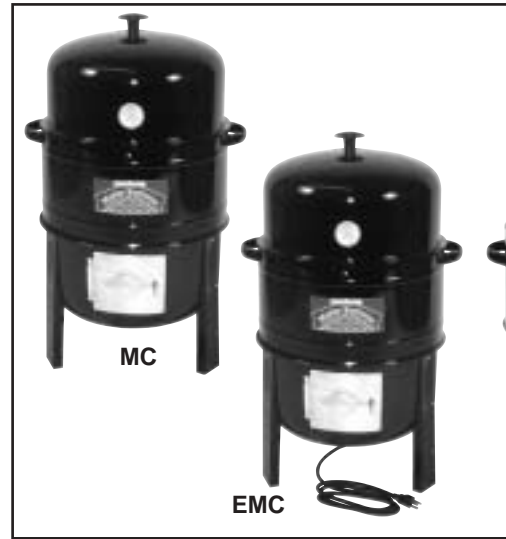

Above model numbers are for black units.  
If your unit is of a different color the model number should be added to the beginning of the above information.  
Assembly and operation will remain the same.  
Parts Lists and Assembly Instructions  
Cooking Chart.....  
Recipes.....

Failure to follow these warnings and instructions could result in fire or explosion, which could cause property damage.

Cooking Tips and Recipes  
Save This Manual For Future Reference  
All Models are for Outdoor Use  
Assembly Instructions  
MC, EMC, SMMC & ESMMC  
8/31/98



# WARNINGS

Read and follow ALL WARNINGS and INFORMATION carefully before operating this appliance.

- The **MASTERBUILT** Charcoal Smoker is for **OUTDOOR USE ONLY**. **DO NOT** use inside an enclosed area or overhang of a house or building.
- **NEVER** use appliance on combustible surfaces or within 10 feet of combustible materials such as wood, dry grass, shrubs, etc.
- **DO NOT** use this product for other than its intended purposes.
- This appliance is not intended for commercial use; it is not intended as, nor should it be used as, a heater.
- **DO NOT** leave appliance unattended while in use or until it cools completely.
- Keep children and pets away from your appliance when in use and until unit cools completely.
- **DO NOT** move the appliance while it is in use. Allow the appliance to cool before moving or storing it.
- When in use, the appliance must be on a level, stable surface. An asphalt surface (black top) is not acceptable for this purpose.
- **ALWAYS** wear shoes during operation.
- **ALWAYS** wear cooking gloves when removing dome or body. Avoid touching hot surfaces.
- Attachments NOT manufactured by MASTERBUILT Mfg. for this product are NOT recommended.
- This appliance is not intended to be installed in or on recreational vehicles such as RV's, boats ect.
- **DO NOT** lean over the appliance when lighting. Be careful of loose hair and clothing during operation.
- **DO NOT** allow anyone to conduct activities around your appliance during or following its use and until it has cooled. The appliance is hot during operation and remains hot for a period of time following use.
- Be careful when removing food from the appliance.
- **NEVER** use glassware, plastic or ceramic cookware on or in your appliance.
- The use of alcohol and prescription or nonprescription drugs may impair the consumer's ability to properly assemble or safely operate the appliance.
- **REMEMBER THIS UNIT IS FOR OUTDOOR USE ONLY!**
- **DO NOT** leave hot coals or ashes unattended until appliance cools completely.
- **NEVER** add lighter fluid to existing hot or warm coals.
- **NEVER** use gasoline or other highly volatile fluids as a starter. They can explode.
- If you use charcoal lighting fluid, allow charcoal to burn until it is covered with a light ash. Then place upper smoker body on lower base pan and cover with dome lid. Following this procedure protects the finish of the unit and keeps fumes from being trapped in the appliance which could result in a flash fire or explosion.
- Lighter fluid should be capped immediately and placed a safe distance (20 feet) from your appliance before lighting coals.
- As an alternative to lighter fluid, use an electric charcoal starter, solid fire or metal chimney starter.
- Once your charcoal is lit, do not touch the charcoal to see if it is hot.
- Use extreme caution when removing smoker dome lid, keeping hands, face and body safe from possible flare-ups or hot steam.
- In the event of a grease fire from meat drippings, cover your smoker with dome lid to suffocate flame.
- Allow coals to burn out completely and let the ashes cool for at least 48 hours before disposing of them.
- Dispose of cold ashes by wrapping them in heavy duty aluminum foil and putting them in a noncombustible container. Be sure there are no other combustible materials in or near the container.
- If you must dispose of the ashes in less time than it takes for them to completely cool, remove ashes from the appliance, keeping them in heavy duty foil, and soak them completely with water before disposing of them in a noncombustible container.
- **NEVER** use charcoal as a heating fuel or for other than cooking outdoors. Using charcoal indoors can kill you. Read and follow all warnings and instructions on your charcoal package.

### For your SAFETY

When the smoker is in operation, use extreme caution when removing the dome lid or body and opening the access door. Handles are hot.

**WARNING:** Do Not Use Electric Smoker In Or Around Water. This Could Cause An Electric Shock Leading To Injury Or Death.

**STOP:** Use only 110 Volt current ONLY: If element will not heat up, it may be that several other appliances are using same 110 line. Locate one less used. Never use a drop cord this will reduce wattage dropping heat from element causing longer cook time.

## 1 OUTDOOR USE ONLY / NEVER LEAVE UNATTENDED

Charcoal Smoker WA  
To validate your warranty, please  
return this card to us within 30 days of  
purchase. Send to: MASTERBUILT Mfg.,  
450 Brown Avenue,

Cut Line

1. Name \_\_\_\_\_
2. Address \_\_\_\_\_  
City \_\_\_\_\_  
State \_\_\_\_\_
3. Dealer's Name \_\_\_\_\_
4. Dealer's Location \_\_\_\_\_
5. Date of Purchase \_\_\_\_\_
6. What brand of outdoor cookers have you used?  
7. Model # on Package \_\_\_\_\_
8. Reasons for purchasing your Charcoal Smoker:  
a. Durability \_\_\_\_\_ f. Mfg. Reputation \_\_\_\_\_  
b. Warranty \_\_\_\_\_ g. Value \_\_\_\_\_  
c. Special Offer \_\_\_\_\_ h. Price \_\_\_\_\_  
d. Special Features \_\_\_\_\_ m. Other \_\_\_\_\_  
e. Received as a Gift \_\_\_\_\_ i. Color \_\_\_\_\_
9. How many products of this type do you own? \_\_\_\_\_
10. Where have you read or heard about this product?  
a. Store Display \_\_\_\_\_  
b. Magazine Advertisement \_\_\_\_\_  
c. Newspaper Advertisement \_\_\_\_\_  
d. Television Advertisement \_\_\_\_\_
11. Date of your birth \_\_\_\_/\_\_\_\_/\_\_\_\_
12. Education: (check one)  
a. High School \_\_\_\_\_  
b. Some College \_\_\_\_\_
13. Which best describes your family income?  
a. Under \$15,000 \_\_\_\_\_  
b. \$15,000-\$24,999 \_\_\_\_\_  
c. \$25,000-49,999 \_\_\_\_\_

Cut Line

Please include a favorite recipe of your choice with your card. We would like to give it a try in our magazine or cookbook. MASTERBUILT Mfg., is taking the time to filling out this questionaire.

## WARRANTY INFORMATION

MASTERBUILT Mfg., Inc. warrants all internal components, for three year. MASTERBUILT, Mfg., Inc. warranty does not include rust of smoker units. Paint finish may burn off under normal use and therefore it carries no warranty. MASTERBUILT Mfg., Inc. warrants all other components of the charcoal are electric smoker to be free from defects in materials and workmanship for three year from purchase date. Within this period, MASTERBUILT Mfg., Inc. shall correct any defect by repairing or replacing defective parts of the equipment or making available the parts thereof, F.O.B. Columbus, GA. Registration of warranty card is required. MASTERBUILT Mfg., Inc. requires reasonable proof of purchase and suggests that you keep your receipt. Upon the expiration of such warranty, all such liability shall terminate.

This warranty does not include the cost of property damage due to the failure of the product and does not cover damage due to the misuse, abuse, accident, damage arising out of transportation, or damage incurred through commercial use of this product. THIS EXPRESS WARRANTY IS THE SOLE WARRANTY GIVEN BY THE MANUFACTURER AND IS IN LIEU OF ALL OTHER WARRANTIES, EXPRESSED OR IMPLIED, INCLUDING IMPLIED WARRANTY OR MERCHANTABILITY OR FITNESS FOR A PARTICULAR PURPOSE. Neither MASTERBUILT nor the retail establishment selling this product has authority to make any warranties or to promise remedies in addition to or inconsistent with those stated above. MASTERBUILT's maximum liability, in any event, shall not exceed the purchase price of the product paid by the original consumer/purchaser. Some states do not allow the exclusion or limitation of incidental or consequential damages. In such a case, the above limitations or exclusions may not be applicable.

Notwithstanding this limitation of warranty, the following specific restrictions apply for California residents. If servicing, repairing or replacement of the product is not commercially practicable, the retailer selling the product or MASTERBUILT will refund the purchase price paid for the product, less the amount directly attributable to use by the original buyer prior to the discovery of the nonconformity. In the state of California only, you may take the product to the retail establishment selling this product, in order to obtain performance under warranty.

This expressed warranty gives you specific legal rights, and you may also have other rights which vary from state to state.

## SAFE STORAGE & MAINTENANCE

- **ALWAYS** allow your appliance to cool completely before handling.
- Before storing your appliance, dispose of remaining coals and ashes into a noncombustible container.
- Clean appliance, including special surfaces such as grill racks and water bowls, with cleaning agents. Wipe outside of smoker with a damp rag.
- If any rusting occurs, use steel wool to clean or buff the affected area.
- **NEVER** paint the interior of your appliance. The exterior of your appliance may be touched up by using a high temperature-resistant paint.
- **ALWAYS** cover and store your appliance in a protected area.
- **DO NOT** obstruct flow of combustion and ventilation.

## 9 OUTDOOR USE ONLY / NEVER LEAVE UNATTENDED

## CHARCOAL & ELECTRIC SMO

PLEASE CHECK CONTENTS

### PARTS LIST:

1. 1 Air Damper
2. 1 Round Handle
3. Heat Indicator
4. Dome Lid
5. 2 Grill Racks
6. 2 "U" Shaped Handles
7. Smoker Body
8. 6 Grill Rack Brackets  
(Not Shown)
9. 3 Legs
10. 1 Water Bowl
11. Smoker Access Door  
(Not Shown)
12. Base Pan

### **Additional Parts For:**

**Charcoal Smoker 1 -12 and**

**A. Wood and Charcoal Bowl**

**Electric Smoker 1 -12 and**

**B. 110 Volt Electric Element  
and Element Disk**

### CHARCOAL or ELECTRIC SMOKER PLACEM

1. Place base pan (12) on ground.
2. Place charcoal/wood bowl (A) in base pan covering large center hole or the electric element disk (B) over large hole and rest element on top.
3. Place water bowl (10) on brackets in base pan. Place a grill rack (5) directly on top of water bowl.
4. Place smoker body (7) on top of base pan.
5. Place the other grill rack on top brackets in smoker body.
6. Place dome lid (4) on of smoker body.

### **SEASONING YOUR SMOKER**

To season your smoker, light the smoker and maintain between warm and ideal. Place charcoal/wood bowl or on element disk and add water for two to four hours before using it. This process removes that new smoker unit smell.

\*\*\*\*\***IMPORT**

# Charcoal Smoker Assembly

Models MC and SMMC

## DOME

1. Attach Round handle to top of dome lid using screw located in handle.

**NOTE: BE CERTAIN TO SECURELY TIGHTEN HANDLE WITH A SCREWDRIVER.**

**DO NOT TURN HANDLE TO TIGHTEN.**

Air damper is Pre-mounted.

## HEAT INDICATOR

2. Install heat indicator in dome by aligning the notches on back of indicator with grooves in hole on dome lid. Rotate indicator until "Indirect grilling" is top center.

## SMOKER BODY

3. Mount 2 handles to smoker body using 1/4 x 1 inch bolts and nuts.  
Mount 3 brackets into upper smoker body using 3/16 x 1/2 inch long bolts and nuts.  
Tighten bolts securely with brackets in place and nuts on inside of smoker body.

## BASE PAN

4. Mount the legs and brackets into the base pan using the same 3/16 x 1/2 inch bolt and nut, through top hole of leg.
5. Secure bottom two holes in leg using 3/16 x 2 inch bolts and nuts. Two per leg.

### Note

One leg has a round knock out Plug in it. Mount it to the back side of the base pan directly behind the smoker door.

This hole is only used when assembling an electric smoker or if you would like to convert your charcoal smoker to electric.

## SMOKER DOOR

1. Mount door hinge to opening in the side of the base pan. Hinge can be secured to the inside or the outside of opening using the two #10 nuts and bolts supplied.

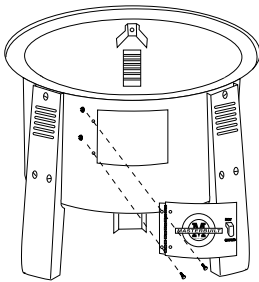

3

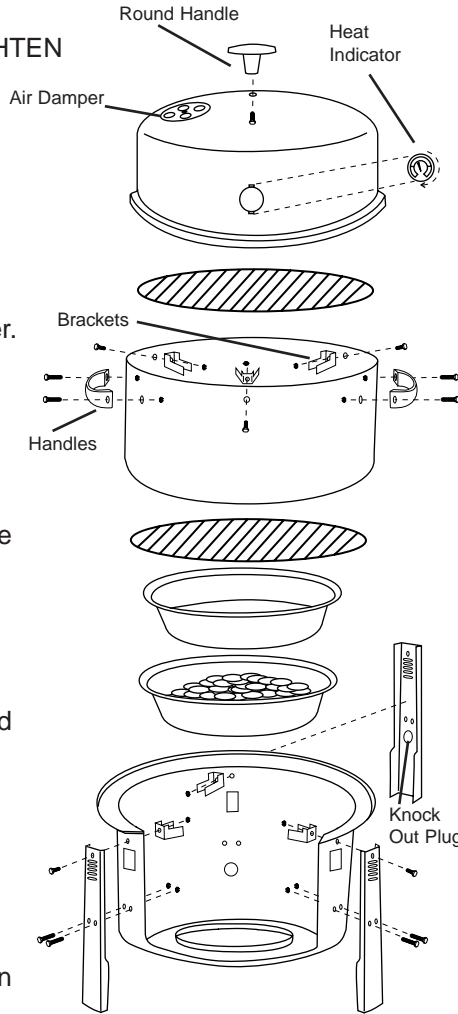

### QUICK TIP

**Place dome lid on smoker body only when charcoal has turned to a light ash.**

## SMOKING RECIPES (Continued)

### SMOKED SHRIMP KEBABS with GARLIC COCKTAIL SAUCE

36 large shrimp, peeled and deveined (tails left intact)  
2 large red bell peppers, cut into 1-inch pieces  
Commercial Italian dressing  
Garlic cocktail sauce

Alternately thread shrimp and red pepper pieces onto 12 wooden skewers. Place in a shallow container and drizzle with Italian dressing. Cover and refrigerate at least 2 hours. Drizzle salad dressing from kabobs. Place shrimp kebabs on top cooking grate. Cover with smoker dome and cook 15 minutes or until shrimp is pink and firm to the touch. Serve warm with garlic cocktail sauce.

### BAKED POTATOES & CORN ON THE COB

Corn can be wrapped in foil or soaked in water and smoked right in the husk. Potatoes wrapped in foil or cooking nails may be used.

### SAUSAGE

The Kolbase (Polish sausage), Italian Sausage or any smoked sausage cooks great. Requires about 5 lbs. of hardwood briquette, hardwood, 1/2 pan water. Let smoke for about 1 or 1 1/2 hrs. Sausage makes excellent kebabs with using unused grill space.

### MUSHROOMS, CAULIFLOWER or SQUASH

Your favorite vegetables can be smoked for a cook-out flavor. By smoking vegetables, you seal in the nutrients and vitamins which can get lost through average cooking. After wrapping loose vegetables in foil add Italian dressing, salt, pepper, peppers and onions.

## COOKING TIPS

### CHARCOAL

- You may need to add additional charcoal during cooking. Follow the instructions and warnings in the manual.
- Dry, hard woods will burn hotter than charcoal. Use wood to charcoal.
- Always wear cooking gloves when removing charcoal when adding charcoal or wood, being careful not to burn yourself.

**NOTE: NEVER ADD LIGHTER FLUID TO CHARCOAL AS AN INDOOR HEATING SOURCE.**

**OUTDOOR USE ONLY / NEVER USE INDOORS**

# RECIPES

## SMOKING RECIPES

### SMOKE ROASTED ASPARAGUS IN GARLIC

- 1 small onion, thinly sliced
- 1 1/2 pounds fresh asparagus, trimmed
- 2 tablespoons of butter or margarine
- 4 cloves garlic, thinly sliced
- 2 tablespoons lemon juice
- 1/4 teaspoon of pepper

Line the bottom of a shallow 1-quart gratin dish with onion slices; arrange asparagus over onion slices; set aside.

Melt butter in a small skillet over low heat; add garlic and cook until tender. Remove from heat and stir in lemon juice, salt and pepper. Drizzle garlic mixture evenly over asparagus. (Do not cover dish). Place dish in top cooking grate of smoker. Cover with smoker lid and cook 1 hour or until crisp and tender.

### SMOKED FISH FILLETS

- 3 lbs. fish fillets
- 1 stick butter
- Juice from 1 lemon
- 1/2 tsp. Worcestershire sauce
- 5 to 6 dashes Tabasco sauce
- 1/4 cup parsley, chopped

Fashion a tray with 2 inch sides of heavy aluminum foil. Place filets in a single layer. Combine butter, lemon juice, sauces and parsley, and pour over fish. Place on grill in smoker, cover with top and cook for one to two hours.

## COOKING TIPS

### WOOD

- A variety of wood chunks may be used. For example: mesquite, hickory, pecan, apple or cherry. Do not use resinous woods such as pine.
- Use chunks around 3" to 4" long and approximately 1/2" or 1" thick. Soak wood in water, wrap in foil and pierce holes in foil. You will need approximately 3 chunks or sticks.

### WATER BOWL

- Line water bowl with aluminum foil before each use. This will make it easy to clean and help your water bowl last longer.
- If water level is low, add more water to the bowl. Move your food aside and pour water slowly through cooking racks, being careful not to splash or overflow water.

## 7 OUTDOOR USE ONLY / NEVER LEAVE UNATTENDED

### SMOKED HAM

- 1 10-lb. precooked ham
- 1/4 cup crushed pineapple
- 1/2 cup honey
- 2 tablespoons soy sauce (Dale sauce may be substituted, if available)

Remove fat from ham. Score top of ham about 1/4" deep. Put water bowl under middle grill rack. Do not add any liquid to water bowl (dry smoke). Place ham on middle grill rack with scored side up. Place 2-3 wood chunks on charcoal, or bottom of base pan. Baste top of ham every hour with mixture. Cook 4 hours or until 140°F inside ham.

### SMOKED TURKEY

- 6 to 8 lb. turkey
  - 2 cups of hickory or apple chips
- Soak the chips in water for at least one hour. This will create smoke, smoldering instead of burning them. Rinse the turkey and dry well. Fold the wings close to the body and tie or skewer. Close both openings with skewers and tie the legs together tightly.

Secure with holding forks. Place on the rack over low, indirect heat with the water pan underneath. Throw half of the drained wood chips on the hot coals. Cook for approximately 2 1/2 hours. Be sure to keep the lid down and the smoke in. Let rest 10 minutes before carving.

## Electric Smoker Models EMC

### DOME

1. Attach Round handle to top of dome lid screw located in handle.  
**NOTE: BE CERTAIN TO SECURELY HANDLE WITH A SCREWDRIVER. DO NOT TURN HANDLE TO TIGHTEN.** Air damper is Pre-mounted.

### HEAT INDICATOR

2. Install heat indicator in dome by aligning the notches on back of indicator with grooves in hole on dome lid. Rotate indicator until "Indirect grilling" is top of indicator.

### SMOKER BODY

3. Mount 2 handles to smoker body using 1/4 x 1 inch bolts and nuts.  
Mount 3 brackets into upper smoker body using 3/16 x 1/2 inch long bolts and nuts. Tighten bolts securely with brackets in place and nuts on inside of smoker body.

### BASE PAN

4. Mount the legs and brackets into the base pan using the same 3/16 x 1/2 inch bolts and nuts, through top hole of leg.
5. Secure bottom two holes in leg using 3/16 x 2 inch bolts and nuts. Two per leg.  
Special NOTE For Mounting Third Leg: One leg has a round knock out plug in the base pan. Remove knock out plug from leg and base pan and mount it to the back side of the base pan directly behind the smoker door. Before securing with nuts and bolts, thread electric cord through the base pan and the leg holes allowing element to rest on top of the disk.

### SMOKER DOOR

1. Mount door hinge to opening in the side of the base pan. Hinge can be secured to the inside or the outside of opening using the two #10 nuts and bolts supplied.

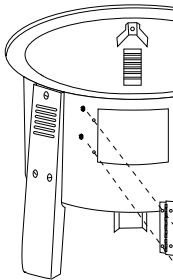

### CHARCOAL and ELECTRIC SMOKER

1. Remove dome lid and upper body from base pan.
  2. Remove grill rack and water bowl from base pan.
  3. Add charcoal to charcoal/wood bowl in base pan.
  4. Soak charcoal with lighter fluid and wait at least 2 minutes for fluid to saturate the charcoal. Always store your lighter fluid away from your smoker before lighting.
  5. Light the charcoal carefully with a light match. Allow charcoal to burn until covered with a light ash.
  6. Place water bowl inside base pan.
  7. Fill water bowl with your favorite marinade or water. Do not overfill the water bowl. (Line your water bowl with aluminum foil for easier clean up.)
  8. Place grill rack on top of water bowl and add food. Place upper body on base pan. Add grill rack, food and dome lid.
  9. Open the smoker access door carefully when adding charcoal or wood chips in bowl. Use extreme caution because the door is hot. \*Never move your smoker while it is in use and allow it to cool completely before moving or handling.
- SMOKE IS ONLY GENERATED WHEN WOOD IS ADDED TO CHARCOAL BOWL OR ELEMENT DISK.

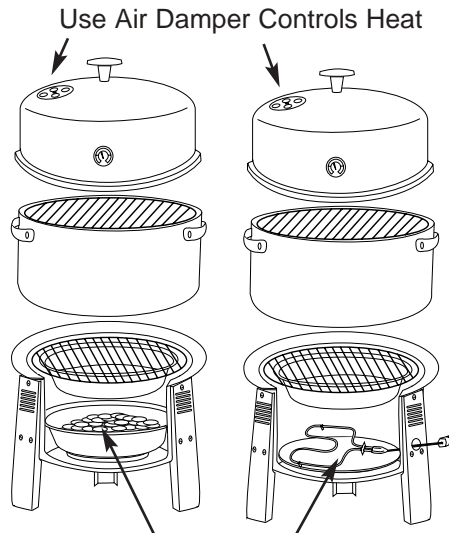

Use Air Damper Controls Heat

Place Wood Here For Smoking

**NOTE: NEVER USE MORE THAN 5 LBS. OF CHARCOAL OR 24 BRIQUETTES AT A TIME.**

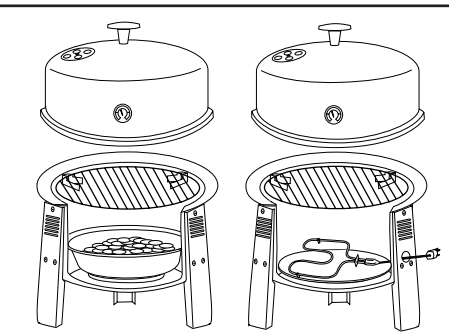

Remove Water Bowl & Smoker Body

### CHARCOAL and ELECTRIC GRILL

#### FIRST Remove Smoker Body and Water Bowl For Direct Grilling

1. Place 24 charcoal briquettes in charcoal/ wood bowl and saturate with lighter fluid or use quick start charcoal. Follow charcoal instructions and warnings.
2. If you've added lighter fluid to the charcoal, allow fluid to soak 2 minutes before lighting.
3. Light charcoal carefully and allow it to burn down to a light ash.
4. Add one grill rack to base pan, then add your food and cover with the dome lid only when charcoal has turned to a light ash and is no longer on fire.
5. Always use caution when operating your grill. Always wear cooking gloves to remove dome lid. For your safety, always wear shoes when using the smoker.
6. Do not move your smoker unit while it is in use. Allow it to cool completely before handling, moving or storing.
7. Always dispose of coal properly as instructed in warnings for using your charcoal grill and smoker.
8. Open the smoker access door carefully when adding charcoal or wood chips. Use extreme caution and wear cooking gloves because the door is hot.

### 5 OUTDOOR USE ONLY / NEVER LEAVE UNATTENDED

## Cooking

BEEF	Quantity Needed	Heat Setting	Char (Am)
Whole rump roast	3 - 4 lbs.	IDEAL	5 - 7
Pot roast (arm, chuck, blade, top, bottom round)	4 - 5 lbs.	IDEAL	7 - 8
Short ribs	3 - 4 lbs. 4 - 6 lbs.	IDEAL IDEAL	5 - 7 7 - 8
Brisket	3 - 4 lbs.	IDEAL	7 - 8
Steak	5 - 7 lbs.	IDEAL	8 - 1
PORK			
Loin roast, bone in	3 - 4 lbs. 5 - 7 lbs.	IDEAL IDEAL	8 lbs 8 lbs
Loin roast, boneless	3 - 5 lbs.	IDEAL	10 lbs
Spareribs	4 - 6 lbs. 7 - 10 lbs.	IDEAL IDEAL	8 - 1 10 lbs
Country Style back ribs	4 - 6 lbs.	IDEAL	7 - 1
Pork Chops 1-inch thick	6 - 10 chops	IDEAL	5 - 7
HAMS			
Fully-cooked	5 - 7 lbs.	IDEAL	7 - 8
Pre-cooked	8 - 10 lbs. 16 - 18 lbs.	IDEAL IDEAL	10 lbs 10 lbs
Fresh			
POULTRY			
Chicken (2 whole)	2-3 lbs. each	IDEAL	5 - 7
(4 whole)	2-3 lbs. each	IDEAL	8 - 1
Hen (one)	5 lbs.	IDEAL	10-1
Turkey	8 - 10 lbs. 11 - 13 lbs. 14 - 16 lbs.	IDEAL IDEAL IDEAL	8 lbs 8 - 1 10-1
LEG OF LAMB	5 - 7 lbs.	IDEAL	8 lbs
VEAL RUMP ROAST	3 - 5 lbs.	IDEAL	5 - 7
FISH & SEAFOOD			
Whole fish	4 - 6 lbs.	IDEAL	7 lbs
Fillet	Full grid	IDEAL	5 lbs
Whole salmon	6 - 7 lbs.	IDEAL	10 lbs
Shrimp, crab legs, lobster, clams	Full grid	IDEAL	5 lbs
WILD GAME			
cornish hens	4 hens	IDEAL	5 - 7
Small game birds (Quail, dove, etc.)	12 - 16 birds	IDEAL	7 - 1
Large game bird (Pheasant, duck, goose, etc.)	5 - 7 lbs.	IDEAL	8 - 1

- When the outside temperature is cooler than 60°F and the altitude is above 3,500 feet, we suggest adding more cooking time. (If you are not sure the meat is cooked, use a meat thermometer to test the meat.)
  - Do not lift your smoker lid during the smoking process to check food. This will extend your cooking time and heat escape.
  - If you are using only one grill rack, use the upper rack for better results. If you need to use both racks place the meat that requires the least cooking time on the top grill.
- NOTE:** When using an electric element, the heat and cooking time many vary due to wattage and temperature change.