

This Owner's Manual is provided and hosted by [Appliance Factory Parts](http://www.appliancefactoryparts.com).

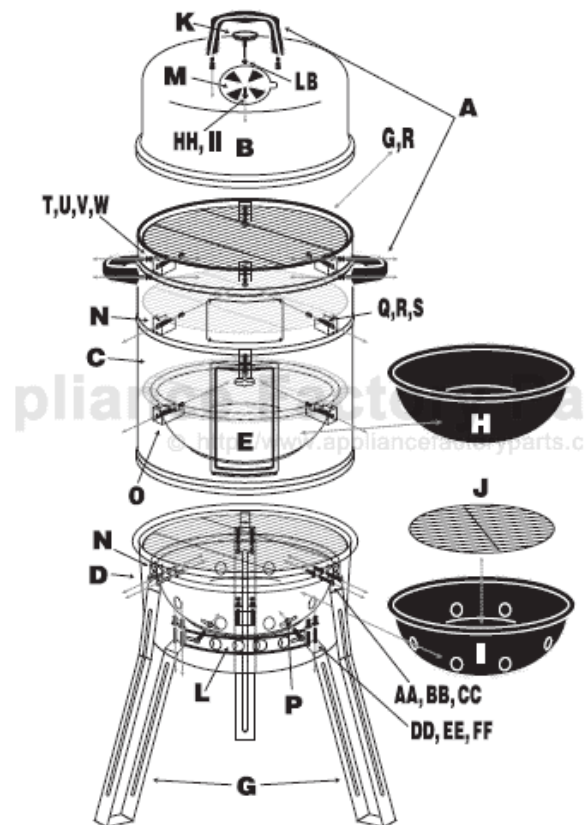

MASTERBUILT GMSSDCS Owner's Manual

[Shop genuine replacement parts for MASTERBUILT GMSSDCS](#)



[Find Your MASTERBUILT Grill Parts - Select From 589 Models](#)

----- Manual continues below -----

Masterbuilt Outdoor Products has made every effort to provide you with a quality, long-lasting, trouble-free product.

In the event of a problem, please call our toll free number

1-800-489-1581

Thank You for purchasing this MASTERBUILT product.



450 Brown Avenue
Columbus, Georgia 31906



Grand
TRIPLE
DELUXE CHARCOAL
MODEL NUMBERS:

ASSEMBLY & OPERAT
WARNING & SAFE



⚠ WARNING:

FOR OUTDOOR USE ONLY. Carbon Monoxide Hazard (See Serial Plate On Unit). Never use indoors (home, garage, enclosed porch, tent). Keep the smoker away from buildings, garages, flammable materials, flammable fluids and automobiles while in use.

Do not leave unit unattended at any time.

⚠ WARNING:

1. Never use indoors. Outdoor use only.
2. Use a commercially prepared fire starter only. Do not use gasoline, alcohol or other highly volatile fluids to ignite charcoal. Do not use excessive lighter fluid.
3. Do not use water to extinguish the fire, as this will damage the porcelain finish.
4. Close all vents to extinguish coals.
5. As with any smoker, care must be taken to prevent heat damage to anything around or under the smoker.
6. Keep away from flammable material and fluids such as gasoline, alcohol, diesel fuels, kerosene, charcoal lighter fluid and/or automobiles.
7. Do not allow children to use the smoker. Keep children and pets away from smoker when in use.
8. Never overfill charcoal bowl. Can damage the unit and cause serious or fatal injury.
9. Do not wear flammable or loose clothing when using smoker.
10. Do not store the smoker with the ashes or combustible materials inside. Do not store the smoker until the fire is completely out and all surfaces are cold.
11. Use heat protective gloves when handling the smoker and handling the fire. Use protective gloves or long sturdy fireplace tools when adding wood or charcoal.
12. Always use in accordance with all applicable local and national fire codes. Use on non-combustible surfaces such as concrete, brick and rock.

1

Masterbuilt WARRANTY

To validate your warranty, please
within 30 days of

Se
MASTERBU
450 Bro
Columbus,

1. Name _____
2. Address _____

City _____

State _____
3. Dealer's Name _____
4. Dealer's Location _____
5. Date of Purchase _____
6. What brands of outdoor cooker

7. Serial # _____

Thank you for your purchase and

WARRANTY INFORMATION:

Masterbuilt Outdoor Products warrants the TRIPLE CROWN DELUXE CHARCOAL SMOKER (GMDCS) and the STAINLESS-STEEL TRIPLE CROWN DELUXE CHARCOAL SMOKER (GMSSDCS) to be free from defects in material and workmanship for one year. This Masterbuilt Outdoor Products warranty does not cover rust of the unit. Within this period, Masterbuilt Outdoor Products shall correct any defect by repairing or replacing defective parts of the equipment.

Masterbuilt Outdoor Products requires reasonable proof of purchase and suggests that you keep your receipt. Failure to complete and return warranty information will make product warranty null and void. Upon the expiration of such warranty, all such liability shall terminate.

This warranty does not include the cost of property damage due to the failure of the product and does not cover damage due to the misuse, abuse, accident, damage arising out of transportation, or damage incurred through commercial use of this product. THIS EXPRESS WARRANTY IS THE SOLE WARRANTY GIVEN BY THE MANUFACTURER AND IS IN LIEU OF ALL OTHER WARRANTIES, EXPRESSED OR IMPLIED, INCLUDING IMPLIED WARRANTY OR MERCHANTABILITY OR FITNESS FOR A PARTICULAR PURPOSE. Neither Masterbuilt Outdoor Products nor the retail establishment selling this product, has authority to make any warranties or to promise remedies in addition to or inconsistent with those stated above. Masterbuilt Outdoor Products maximum liability, in any event, shall not exceed the purchase price of the product paid by the original consumer/ purchaser. Some states do not allow the exclusion or limitation of incidental or consequential damages. In such a case, the above limitations or exclusions may not be applicable.

Notwithstanding this limitation of warranty, the following specific restrictions apply for California residents. If service, repair, or replacement of the product is not commercially practicable, the retailer selling the product or Masterbuilt Outdoor Products will refund the purchase price paid for the product, less the amount directly attributable to use by the original buyer prior to the discovery of the nonconformity. In the state of California only, you may take the product to the retail establishment selling this product, in order to obtain performance under warranty.

This expressed warranty gives you specific legal rights, and you may also have other rights which vary from state to state.

NOTE: Paint finish may burn off under normal use and therefore it carries no warranty.

CAUTION:

Never move the unit while in use. If moving the body or lid as they may be very hot.

GENERAL INSTRUCTIONS SAFE USE OF SMOKER

1. Do not burn trash, leaves, paper, etc. The use of seasoned hardwood is preferred, such as pine or cedar because they burn cleaner.
2. Keep all screws and nuts tight to maintain proper operating conditions. Inspect on regular basis to ensure proper operational.

NOTE: After repeated use, a discoloration may occur on the exterior surface.

⚠️ WARNING

CARBON MONOXIDE

Burning charcoal gives off carbon monoxide, a colorless, odorless gas that is highly flammable and can kill you. DO NOT use in enclosed spaces, such as vehicles or tents. Use only in well-ventilated areas.

Please read all instructions and warnings before assembly.

TOOLS REQUIRED:

Phillips head screwdriver, Crescent wrench or socket wrench set.

NOTE: Do not completely tighten screws until the assembly is complete. For easier assembly we recommend two people assemble this product.

PARTS LIST/IDENTIFICATION:

PART NUMBER	DESCRIPTION	QUANTITY
GR	Grill Racks	3
A	Handles	3
B	Dome	1
C	Middle Body	1
D	Bottom Body	1
E	Charcoal Door With Handle	1
G	Legs	3
H	Water Bowl	1
I	Charcoal Bowl	1
J	Charcoal Bowl Rack	1
K	Deluxe Heat Indicator	1
L	Bottom Air Damper	2
M	Top Air Damper	1
N	Grill Brackets	6
O	Long Grill Brackets	3
P	Wings Nuts & Bolts	4
LB	Large Bolt For Heat Indicator	1
	Mounting Grill Brackets	
Q	Short Bolts	9
R	Lock Washers	9
S	Nuts	9
	Mounting Handles	
T	Short Silver Bolts	6
U	Silver Washers	6
V	Silver Lock Washers	6
W	Silver Nuts	6
	Mounting Top of Legs	
AA	Long Bolts	6
BB	Lock Washers	6
CC	Nuts	6
	Mounting Bottom of Legs	
DD	Short Black Bolts	6
EE	Lock Washers	6
FF	Nuts	6
HH, II	Bolt and Nut	1 Each

Cooking Chart for Gas

BEEF	Quantity	Heat Setting	Char (Approx)
Whole rump roast	3 - 4 lbs.	200°	5 - 7
Pot roast (arm, chuck, blade, top, bottom round)	4 - 5 lbs.	200°	7 - 8
Short ribs	3 - 4 lbs.	200°	5 - 7
	4 - 6 lbs.	200°	7 - 8
Brisket	3 - 4 lbs.	200°	7 - 8
Steak	5 - 7 lbs.	200°	8 - 10
PORK			
Loin roast, bone in	3 - 4 lbs.	200°	8 lbs.
	5 - 7 lbs.	200°	8 lbs.
Loin roast, boneless	3 - 5 lbs.	200°	10 lbs.
Spareribs	4 - 6 lbs.	200°	8 - 10
	7 - 10 lbs.		10 lbs.
Country Style back ribs	4 - 6 lbs.	200°	7 - 10
Pork Chops 1-inch thick	6 - 10 chops	200°	5 - 7
HAMS			
Fully-cooked	5 - 7 lbs.	200°	7 - 8
Pre-cooked	8 - 10 lbs.		10 lbs.
Fresh	16 - 18 lbs.		10 lbs.
POULTRY			
Chicken(2 whole)	2-3 lbs. each	200°	5 - 7
(4 whole)	2-3 lbs. each		8 - 10
Hen (one)	5 lbs.		10-12
Turkey	8 - 10 lbs.	200°	8 lbs.
	11 - 13 lbs.		8 - 10
	14 - 16 lbs.		10-12
LEG OF LAMB	5 - 7 lbs.	200°	8 lbs.
VEAL RUMP ROAST	3 - 5 lbs.	200°	5 - 7
FISH & SEAFOOD			
Whole fish	4 - 6 lbs.	200°	7 lbs.
Fillets	Full grid		5 lbs.
Whole salmon	6 - 7 lbs.		10 lbs.
Shrimp, crab legs, lobster, clams	Full grid	200°	5 lbs.
WILD GAME			
cornish hens	4 hens	200°	5 - 7
Small game birds (Quail, dove, etc.)	12 - 16 birds		7 - 10
Large game bird (Pheasant, duck, goose, etc.)	5 - 7 lbs.	200°	8 - 10

- When the outside temperature is cooler than 50° and the altitude is above 3,500 feet, we suggest adding more cooking time. (If you are not sure if your meal is cooked, use a meat thermometer to test the meat.)
- Do not lift your smoker lid during the smoking process to check food. This will extend your cooking time due to heat escape.
- If you are using only 1 grill rack, use the upper rack for better results. If you need to use both racks place the meat that requires the least cooking time on the top grill rack.

STEP 3: Dome Assembly

FIRST, mount Deluxe Heat Indicator **K** to top of Dome using the Large Heat Indicator Bolt **LB**.

NEXT, mount Handle **A** to Dome **B** with Short Silver Bolts **T**, Silver Washers **U**, Silver Lock Washers **V**, and Silver Nuts **W**.

LAST, Mount Top Air Damper **M**, to Dome **B** using the small Bolt **HH** and the Small Nut **II**.

NOTE: Do not completely tighten screws until the assembly is complete. For easier assembly we recommend two people assemble this product.

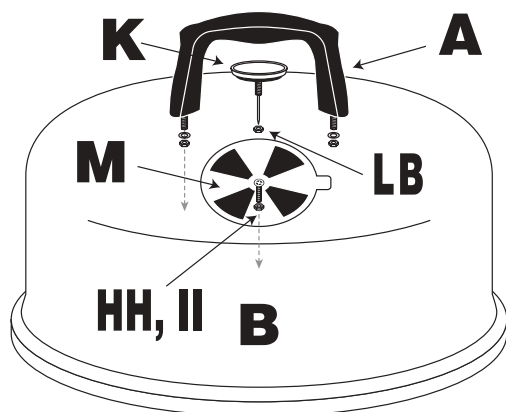

CHARCOAL LIGHTING INSTRUCTIONS:

Read all instructions and warnings on charcoal bag and in this manual before operating.

1. Stack approximately 45-50 briquets in a pyramid.
DO NOT OVERFILL CHARCOAL BOWL.
 3. Add lighter fluid following lighter fluid instructions. Light charcoal.
LEAVE DOME LID OFF.
 2. Once the flames die out and charcoal begins to ash over, spread coals out evenly and begin cooking.
- Hot coals must be completely out and cooled before storing unit or leaving unattended.

7

WARNING:

SMOKER IS FOR OUTDOOR USE ONLY.
INDOOR USE CAN BE FATAL TO HUMANS.
NEVER LEAVE UNATTENDED WHILE IN USE.

ASSEMBLY INSTRUCTIONS

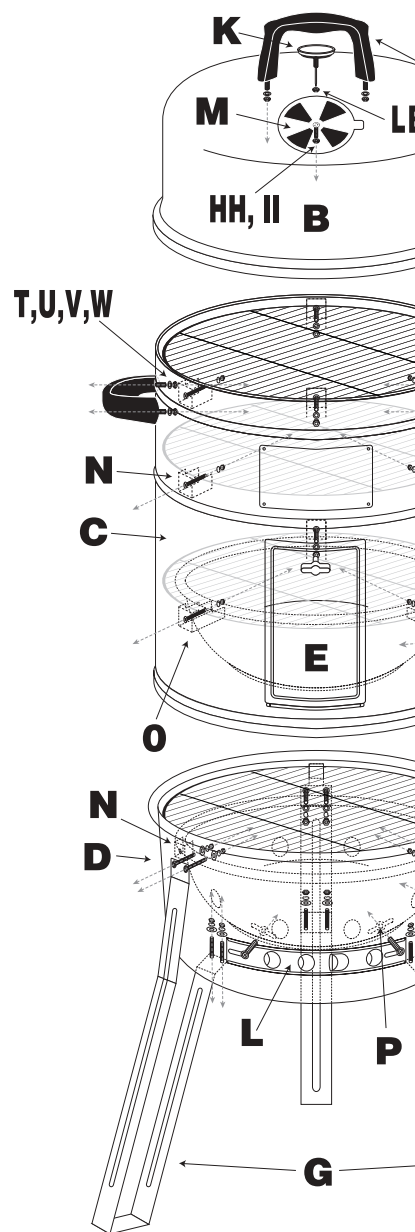

STEP 1: Bottom Body & Leg Assembly

FIRST, Mount the tops of Legs **G** to Bottom Body **D** using six Long Bolts **AA** (two for each leg), two Lock Washers **BB** (two for each leg), and two Nuts **CC** (two for each leg).

Mount the bottoms of Legs **G** to Bottom Body **D** using six Short Bolts **DD** (two for each leg), two Lock Washers **EE** (two for each leg), and two Nuts **FF** (two for each leg).

NEXT, mount bottom Air Damper **L** to bottom body using Wing Nuts and Bolts **P**.

LAST, mount Short Grill Brackets **N**, Bottom Body **D**, using Short Bolts **Q**, Lock Washers **R**, and Nuts **S**. Place Charcoal Bowl Grill Rack **J** inside Charcoal Bowl **I** and place inside bottom of Bottom Body **D**. Place one Grill Rack **GR** on top of Bottom Body **D**.

NOTE: Do not completely tighten screws until the assembly is complete. For easier assembly we recommend two people assemble this product.

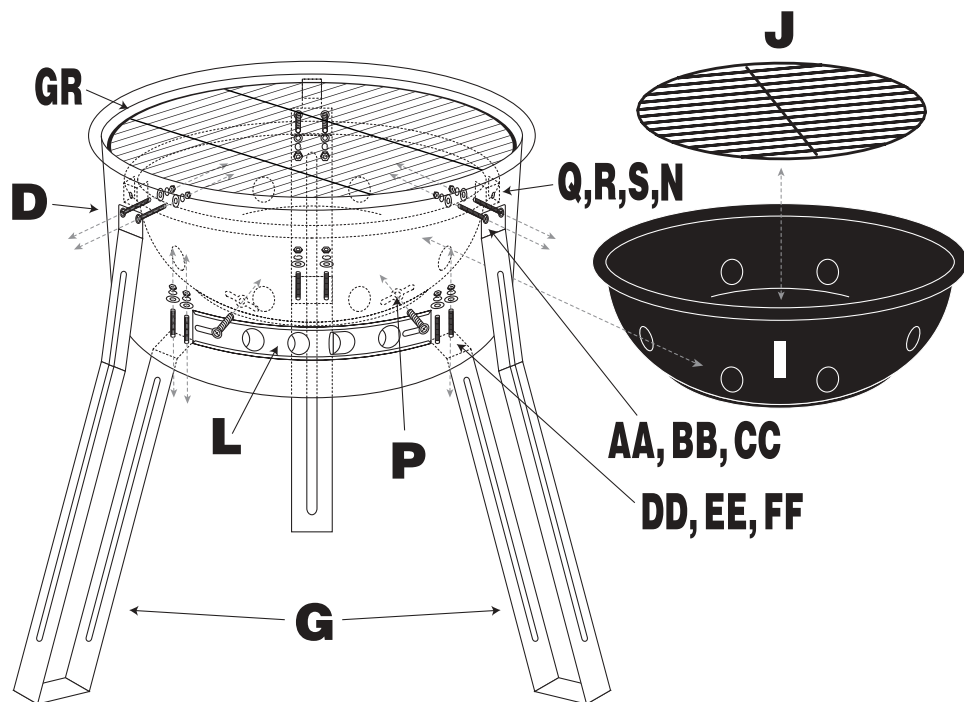

STEP 2: Middle Body Assembly

FIRST, mount Handles **A** to Middle Body **C** (two for each handle), Silver Washers **U** (two for each handle), and Silver Nuts **W** (two for each handle).

NEXT, mount Charcoal Door With Handle **E** to Middle Body **C**. Charcoal Door **E** will slide in to a slot at the bottom of Middle Body **C**.

Mount Short Grill Brackets **N**, to Middle Body **C**, using Short Bolts **Q**, Lock Washers **R**, and Nuts **S**.

Mount Long Grill Brackets **O** to Middle Body **C**, using Long Bolts **T**, Lock Washers **R**, and Nuts **S**.

LAST, place Water Bowl **H** on Long Grill Bracket **O** of Middle Body **C** on top, middle or bottom Grill Bracket of Middle Body **C**.

NOTE: Do not completely tighten screws until the assembly is complete. For easier assembly we recommend two people assemble this product.

