

# MASTERBUILT SMM7 Owner's Manual

Shop genuine replacement parts for MASTERBUILT  
SMM7

#### PARTS LIST:

1. 1 Air Damper
2. 1 Round Handle
3. Heat Indicator
4. Dome Lid
5. 2 Grill Racks
6. 2 "U" Shaped Handles (Not Shown)
7. Smoker Body
8. 6 Grill Rack Brackets (Not Shown)
9. 3 Legs
10. 1 Water Bowl
11. Smoker Access Door (Not Shown)
12. Base Pan
13. Flame Disk
14. Gas Cooker with cast burner and regulator control valve  
Gas Cylinder Not Included

#### Additional Part For: Monarch Smoker Only

- 1 Push Button Auto Ignitor

Private Label Units May Have Added or Different Parts Packaged.  
Model # May Be Different also.

#### PART PLACEMENT

1. Place base pan (12) on top of cooker stand (14) and align base pan legs with cooker legs.
2. Place flame disk (13) in base pan covering large center hole in base pan.
3. Place water bowl (10) on brackets in base pan. Place a grill rack (5) directly on top of water bowl.
4. Place smoker body (7) on top of base pan.
5. Place the other grill rack on top brackets in smoker body.
6. Place dome lid (4) on of smoker body.

#### Tip:

If your burner does not burn blue you need to check the burner venturi for any obstructions. Dirt, Dobbers, Spiders and other insects will build nest blocking air and gas flow.

KEEP AIR SHUTTER CLOSED AFTER EACH USE.

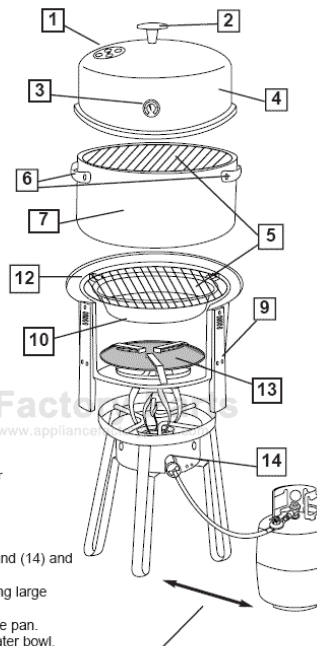

Extend Cylinder 18" Away  
From Cooker While In Use

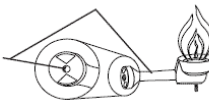

[Find Your MASTERBUILT Grill Parts - Select From 589 Models](#)

----- Manual continues below -----

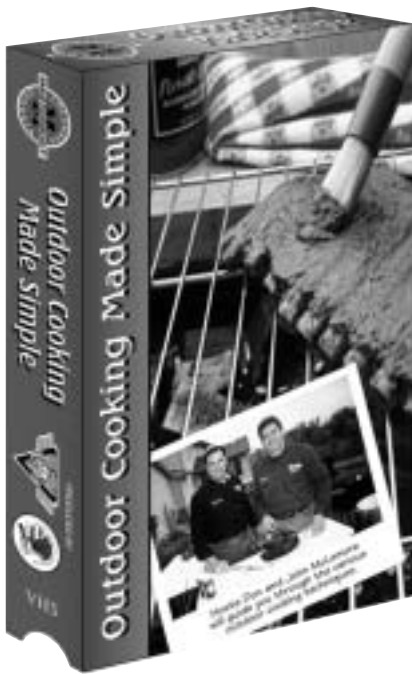

## Free Video Offer

### “Outdoor Cooking Made Simple”

From European and Southern style cooking to Louisiana Cajun and Midwest flavors, hosts Don and John McLemore guide viewers, step by step, through the world of smoking, grilling, frying and boiling. Let more than 20 recipes, tempt your taste buds and open up a world of rich flavor and awesome eating.

# MASTE

Monarch™ and Master Barbe  
**ASSEMBLY AND OPERA**  
**WARNING AND SAFE**



M7

M7P Sold with Pot and Basket

Some units are sold under a private label. The model number may not be listed. You will need the instructions. The model number will be

Units are sold with and  
 Gas cylinder not incl

Viewing Time.....Approximately 48 minutes

### Shipping

Within continental United States.....\$5.95

In Alaska, Hawaii and Canada.....Call (706) 327-5622 EXT. 101 for rates

Yes, I would like the free video and have included my payment for shipping and handling charges.

Call (706) 327-5622 EXT.101 for Visa or Mastercard orders, or send check or money order to: MASTERBUILT Mfg. (See address below.)

### We Can Help....

If you have any questions about your unit, please give us a call FIRST before returning it. Ask For The Customer Service Department. (800) - 489 - 1581 Fax (706) - 327-5622  
[www.masterbuilt.com](http://www.masterbuilt.com)



Send in an envelope to:  
 Masterbuilt Mfg. Inc.,  
 Attn: Warranty Dept.  
 450 Brown Ave., Columbus, GA 31906

For Models: M7 - M7P - SMM7 - SMM7P  
 11-19-98

Cooking Tips and Recipes  
 Save This Manual For  
 All Models are for **OUTDOOR**

Assembly Instructions  
 For Models: M7 - M7P -



# WARNINGS

Read and follow ALL WARNINGS and INFORMATION carefully before operating this appliance.

- These MASTERBUILT units are for OUTDOOR use only. DO NOT use inside an enclosed area or overhang of a house or building.
- NEVER use your appliance near or ON combustible surfaces and materials such as wood, dry grass, shrubs, etc. A minimum distance away from these materials is 10'
- This appliance is not intended for commercial use; it is not intended as, nor should it be used as a heater.
- DO NOT leave appliance unattended. Keep children and pets away from the appliance at all times. Constant supervision is necessary when this product is in use and until appliance has cooled.
- DO NOT move the appliance when it is in use. Allow the appliance to cool before moving or storing it.
- When in use, the appliance must be on a level, stable surface in an area clear of combustible materials. An asphalt surface (black top) might not be acceptable for this purpose.
- ALWAYS wear shoes during operation.
- ALWAYS wear cooking gloves during operation. Avoid touching hot surfaces.
- Accessory attachments NOT manufactured by MASTERBUILT Mfg. for this particular product are NOT recommended.
- This appliance is not intended to be installed in or on recreational vehicles or boats.
- In the event of rain, while frying with oil, cover cooking vessel immediately. Turn the regulator to OFF position, then turn the gas cylinder to OFF position. DO NOT move cooker stand or pot.
- When cooking with oil or grease, make fire-extinguishing materials readily accessible.
- In the event of an oil or grease fire, DO NOT attempt to extinguish with water. Use Type BC dry chemical fire extinguisher or smother fire with dirt, sand or baking soda.

### For your SAFETY

1. DO NOT store or use gasoline or other flammable vapors and liquids in the vicinity of this or any other appliance.
2. When cooking with oil or grease, do not exceed 350° F (177° Celsius). In the event you exceed 350°F, DO NOT add food, oil or grease. Shut off the appliance, allow to cool below 350°F. Repeat the lighting process. DO NOT store or use extra cooking oil in the vicinity of this or any other appliance.
3. An LP cylinder not connected for use shall not be stored in the vicinity of this or any other appliance.

### If you smell gas:

1. Shut off gas to the appliance.
2. Extinguish any open flame.
3. Open lid.
4. If odor continues, call your gas supplier or your fire department immediately.

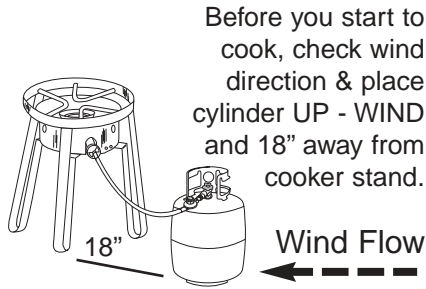

## 1 OUTDOOR USE ONLY / NEVER LEAVE UNATTENDED

M7 - M7P - SMM7 - SMM7P  
 To validate your warranty, please  
 within 30 days of purchase  
 Send to: MASTERBUILT Mfg.  
 450 Brown Avenue,

Cut Line

1. Name \_\_\_\_\_
2. Address \_\_\_\_\_  
 City \_\_\_\_\_  
 State \_\_\_\_\_
3. Dealer's Name \_\_\_\_\_
4. Dealer's Location \_\_\_\_\_
5. Date of Purchase \_\_\_\_\_
6. What brand of outdoor cookers have you used? \_\_\_\_\_
7. Model # on Package \_\_\_\_\_
8. Reasons for purchasing your Unit:
 

a. Durability	f. Mfg. Reputation
b. Warranty	g. Value
c. Special Offer	h. Price
d. Special Features	Mfg. Name
e. Received as a Gift	i. Color
9. How many products of this type do you own? \_\_\_\_\_
10. Where have you read or heard about this product?
  - a. Store Display
  - b. Magazine Advertisement
  - c. Newspaper Advertisement
  - d. Television Advertisement
11. Date of your birth \_\_\_\_/\_\_\_\_/\_\_\_\_
12. Education: (check one)
  - a. High School \_\_\_\_\_
  - b. Some College \_\_\_\_\_
13. Which best describes your family income?
  - a. Under \$15,000 \_\_\_\_\_
  - b. \$15,000-\$24,999 \_\_\_\_\_
  - c. \$25,000-49,999 \_\_\_\_\_

Cut Line

Please include a favorite recipe of your choice with your return.  
 MASTERBUILT Mfg., Inc. thanks you!

## WARRANTY INFORMATION

MASTERBUILT Mfg., Inc. warrants the Monarch™ Grill - Smoker and Cooker with a Limited Lifetime warranty on all parts except the regulator, hose and burner which has a three year warranty. The Master Barbecue™ Grill - Smoker and Cooker has a full three year warranty on the complete unit. All private label units are covered under a three year warranty. MASTERBUILT, Mfg., Inc. warranty does not cover rust on either units. The Master Barbecue™ paint finish may burn off under normal use and therefore it carries no warranty. MASTERBUILT Mfg., Inc. warrants all components to be free from defects in materials and workmanship. Within this period, MASTERBUILT Mfg., Inc. shall correct any defect by repairing or replacing defective parts of the equipment or making available the parts thereof, F.O.B. Columbus, GA. Registration of warranty card is required.

MASTERBUILT Mfg., Inc. requires reasonable proof of purchase and suggests that you keep your receipt. Upon the expiration of such warranty, all such liability shall terminate.

This warranty does not include the cost of property damage due to the failure of the product and does not cover damage due to the misuse, abuse, accident, damage arising out of transportation, or damage incurred through commercial use of this product. THIS EXPRESS WARRANTY IS THE SOLE WARRANTY GIVEN BY THE MANUFACTURER AND IS IN LIEU OF ALL OTHER WARRANTIES, EXPRESSED OR IMPLIED, INCLUDING IMPLIED WARRANTY OR MERCHANTABILITY OR FITNESS FOR A PARTICULAR PURPOSE. Neither MASTERBUILT nor the retail establishment selling this product has authority to make any warranties or to promise remedies in addition to or inconsistent with those stated above. MASTERBUILT's maximum liability, in any event, shall not exceed the purchase price of the product paid by the original consumer/purchaser. Some states do not allow the exclusion or limitation of incidental or consequential damages. In such a case, the above limitations or exclusions may not be applicable.

Notwithstanding this limitation of warranty, the following specific restrictions apply for California residents. If servicing, repairing or replacement of the product is not commercially practicable, the retailer selling the product or MASTERBUILT will refund the purchase price paid for the product, less the amount directly attributable to use by the original buyer prior to the discovery of the nonconformity. In the state of California only, you may take the product to the retail establishment selling this product, in order to obtain performance under warranty.

This expressed warranty gives you specific legal rights, and you may also have other rights which vary from state to state.

### **SAFE STORAGE & MAINTENANCE**

- ALWAYS disconnect your gas cylinder after using your appliance.
- Indoor storage of appliance is permissible only if the cylinder is disconnected and removed.
- Cylinders must be stored outdoors out of the reach of children and must not be stored in a building, garage or any other enclosed area.
- Always store gas cylinder upright and in areas where temperatures won't exceed 125° F, and never store a spare cylinder on or near your cooker stand.
- ALWAYS allow your appliance to cool completely before handling.
- Before storing your appliance, dispose of remaining coals and ashes into a noncombustible container.
- Clean appliance, including special surfaces such as grill racks and water bowls, with cleaning agents. Wipe outside of smoker with a damp rag.
- If any rusting occurs, use steel wool to clean or buff the affected area.
- NEVER paint the interior of your appliance. The exterior of your appliance may be touched up by using a high temperature-resistant paint.
- ALWAYS cover and store your appliance in a protected area.
- DO NOT obstruct flow of combustion and ventilation. Keep the ventilation opening(s) of the cylinder enclosure clear of debris. The cylinder supply system must be arranged for vapor withdrawal.
- Coat cooker stand with cooking oil after unit has cooled.
- Check the regulator hose and burner parts, air shutter and venturi/valve section carefully. ALWAYS turn gas OFF at the gas cylinder valve prior to inspecting parts.
- When appliance is not in use, the gas must be turned off at the supply cylinder.

## WARNINGS

1. When cooking with oil or grease, do not allow the temperature of oil to reach 350° in 7 to 10 minutes. When cooker is in operation NEVER add oil quickly and ignite at 550° to 700°. (One gallon of oil Max in 26qt pots)
2. Do not store extra cooking oil in the vicinity of this or any other cooking appliances.
3. Do not store or use gasoline or other flammable liquids in the vicinity of this or any other cooking appliances.
4. An LP cylinder not connected for use with this or any other cooking appliance.
5. Keep LP gas cylinder up wind when in use.

- DO NOT use this product for other than intended use.
- ALWAYS perform the soapy water test before use.
- Before each use, inspect and clean burner tubes. A clogged tube can lead to a fire.
- NEVER transport your gas cylinder inside a vehicle. Transport it in the back of a pickup truck.
- Keep your hands, hair and face away from the burner when lighting. Be careful of hot surfaces.
- NEVER detach a gas cylinder, move or use a gas cylinder if it shows signs of damage, corrosion, leakage, excessive rust or other damage. The cylinder might be hazardous. Consult your propane dealer.
- When lighting your burner, remove dome cover to prevent gas build up.
- If burner does not ignite, turn off the gas supply and relight. If the burner goes out during operation, turn off the gas cylinder.
- DO NOT allow anyone to conduct activities near the appliance following its use and until it has cooled. The appliance remains hot for a period of time following use.
- NEVER allow the gas hose to touch any hot surfaces.
- To avoid the possibility of severe burns, allow the appliance to cool completely before moving.
- Be careful when removing food from the appliance.
- NEVER use glassware, plastic or ceramic cookware on the appliance.
- When using your boiler/fryer, use caution to avoid pulling the pot off your appliance.
- The use of alcohol and prescription or non-prescription drugs may impair the consumer's ability to properly assemble or use the appliance.
- In a low heat setting, DO NOT allow flames to reach the bottom of the pot.



## WARNINGS (continued)

- THIS UNIT IS FOR OUTDOOR USE ONLY!
- DO NOT leave appliance unattended while in use or until it cools completely.
- Keep children and pets away from your appliance when in use and until unit cools.
- DO NOT leave hot coals or ashes unattended until appliance cools completely.
- NEVER add lighter fluid to existing hot or warm coals.
- NEVER use gasoline or other highly volatile fluids as a starter. They can explode.
- If you use charcoal lighting fluid, allow charcoal to burn until it is covered with a light ash. Then place upper smoker body on lower body and cover with dome lid. Following this procedure protects the finish of the unit and keeps fumes from being trapped in the appliance which could result in a flash fire or explosion.
- Lighter fluid should be capped immediately and placed a safe distance from your appliance before lighting coals.
- As an alternative to lighter fluid, use an electric charcoal starter, solid fire starter, or metal chimney starter.
- After unplugging a hot electric starter, remove it carefully and be careful where you put it. Allow starter to cool completely before storing it.
- NEVER use an electric starter in the rain or when standing on wet ground.
- Once your charcoal is lit, do not touch the charcoal to see if it is hot.
- Use extreme caution when removing smoker dome lid, keeping hands, face and body safe from possible flare-ups or hot steam.
- In the event of a grease fire from meat drippings, cover your smoker with the dome lid to suffocate the flame.
- Allow coals to burn out completely and let the ashes cool for at least 48 hours before disposing of them.
- Dispose of cold ashes by wrapping them in heavy duty aluminum foil and putting them in a noncombustible container. Be sure there are no other combustible materials in or near the container.
- If you must dispose of the ashes in less time than it takes for them to completely cool, remove ashes from the appliance, keeping them in heavy duty foil, and soak them completely with water before disposing of them in a noncombustible container.
- NEVER use charcoal as a heating fuel or for other than cooking outdoors. Using charcoal indoors can kill you. Read and follow all warnings and instructions on your charcoal package.

**Failure to follow these warnings and instructions properly could result in fire or explosion, which could cause property damage, personal injury or death.**

The installation of this cooker must conform with local codes or, in the absence of local codes, with the National Fuel Gas Code, ANSI Z223.1, Storage and Handling of Liquefied Petroleum Gas, NFPA/ANSI58, or CAN/CGA-B149.1, Natural Gas Installation Code or CAN/CGA-B149.2, Propane Installation Code.

3

## Grill Smoker Cooker Cover



Model  
MC53 -  
Cart and  
\$8.95

To Order

**Yes we are the manufacturer of  
The Original HITCH-HAUL®  
Wheel Free Carrier**

Model - HP2 Black

\$89.95

Model - H2A Aluminum

\$119.95

## Turk N' Surf™ Turkey Fry

Model - 26TSB

26qt WIDE BODY pot,  
low profile bailing basket with  
extra long handle, grab hook, lid,  
and Long stem thermometer  
\$79.95



Alu

Model

10.5c

\$29.9

## Double Cookers in Stainless Steel and Black Steel

Model - SMDCL Double Stainless Steel  
\$199.95

Model - MDCL Double Black  
\$109.95

**Large Stock Pots up to 120 Quarts  
Available Call For Pricing or visit  
our WEB Site at [www.masterbu](http://www.masterbu)**

# MASTERBUILT Accessory Shop

Visit us on the WEB at [www.masterbuilt.com](http://www.masterbuilt.com) or Call 800-489-1581

\* Prices may vary from this catalog.

## Thermometers

Model - DFTH  
6" Thermometer  
\$9.95

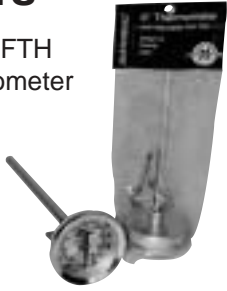

Model - DF10  
10" Thermometer  
\$14.95

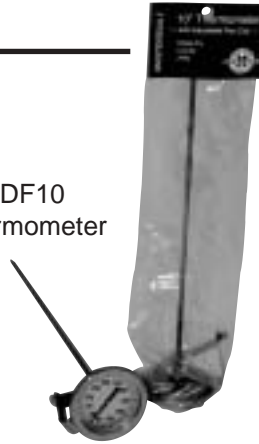

## Auto Ignitor

Model - GSIGN  
Add an Auto Push Button Ignitor to your Master Barbecue Grill Smoker Cooker  
\$9.95

## MASTERBUILT Seasonings

Our #1 Selling Seasoning is Cajun...From Deep Fried Turkey to Grilling and Smoking.



Model - MSOCO1 - Cajun  
7oz Bottle \$4.95

Model - MSOSO1 - Steak  
7.5oz Bottle \$4.95

Model - MSOBO1 - BBQ  
6.5oz Bottle \$4.95

Model - IS35 - Injecting Syringe  
\$5.95

Model - MBCV2 - Cooking Video  
\$9.95



## Grill - Smoker - Cooker AS

PLEASE CHECK CONTENTS

### PARTS LIST:

1. 1 Air Damper
2. 1 Round Handle
3. Heat Indicator
4. Dome Lid
5. 2 Grill Racks
6. 2 "U" Shaped Handles
7. Smoker Body
8. 6 Grill Rack Brackets (Not Shown)
9. 3 Legs
10. 1 Water Bowl
11. Smoker Access Door (Not Shown)
12. Base Pan
13. Flame Disk
14. Gas Cooker with cast burner and regulator control valve  
Gas Cylinder Not Included

### Additional Part For:

#### Monarch Smoker Only

- 1 Push Button Auto Ignitor

Private Label Units May Have Added or Different Parts Packaged.

Model # May Be Different also.

### PART PLACEMENT

1. Place base pan (12) on top of cooker stand a line base pan legs with cooker legs.
2. Place flame disk (13) in base pan covering center hole in base pan.
3. Place water bowl (10) on brackets in base pan. Place a grill rack (5) directly on top of water bowl.
4. Place smoker body (7) on top of base pan.
5. Place the other grill rack on top brackets in smoker body.
6. Place dome lid (4) on of smoker body.

### Tip:

If your burner does not burn blue you need check the burner venturi for any obstruction. Dobbbers, Spiders and other insects will be blocking air and gas flow.

KEEP AIR SHUTTER CLOSED AFTER EACH

# Grill Smoker Cooker Assembly

Models M7 - M7P - SMM7 and SMM7P

## DOME

1. Attach Round handle to top of dome lid using screw located in handle.  
**NOTE: BE CERTAIN TO SECURELY TIGHTEN HANDLE WITH A SCREWDRIVER. DO NOT TURN HANDLE TO TIGHTEN.** Air damper is Pre-mounted.

## HEAT INDICATOR

2. Install heat indicator in dome by aligning the notches on back of indicator with grooves in hole on dome lid. Rotate indicator until "Indirect grilling" is top center.

## SMOKER BODY

3. Mount 2 handles to smoker body using 1/4 x 1 inch bolts and nuts.  
Mount 3 brackets into upper smoker body using 3/16 x 1/2 inch long bolts and nuts.

Tighten bolts securely with brackets in place and nuts on inside of smoker body.

Note: STAINLESS STEEL brackets are different. Mount larger brackets in body and smaller ones in base pan.

## BASE PAN

4. Mount the legs and brackets into the base pan using the same 3/16 x 1/2 inch bolt and nut, through top hole of leg.
5. Secure bottom two holes in leg using 3/16 x 2 inch bolts and nuts. Two per leg. These bolts are longer so that it will secure your water bowl in place when charcoal grilling or smoking.

Note:

One leg has a round knock out Plug in it. Mount it to the back side of the base pan directly behind the smoker door.

This hole is only used when assembling an electric smoker or if you would like to convert your Gas smoker to electric.

## SMOKER DOOR

1. Mount door hinge to opening in the side of the base pan. Hinge can be secured to the inside or the outside of opening using the two #10 nuts and bolts supplied.

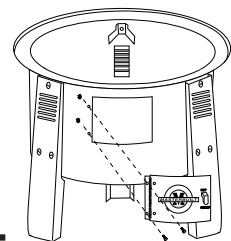

## Push Button Ignitor Assembly

\*The MONARCH (SMM7 & SMM7P) units are sold with and ignitors. This is an optional item for the Master Barbecue unit (M7 & M7P).

1. Bolt ignitor to the outside of cooker using enclosed hardware. The stainless rod should be placed through one of the lighting holes.
2. Bend stainless wire in a way that the very end of the wire is 1/8" above one of the burner port holes.
3. Push red button looking for a blue spark at burner. Adjust wire until spark is achieved.

## Wire to Burner Port

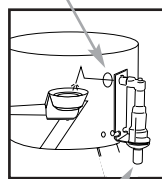

Ignitor

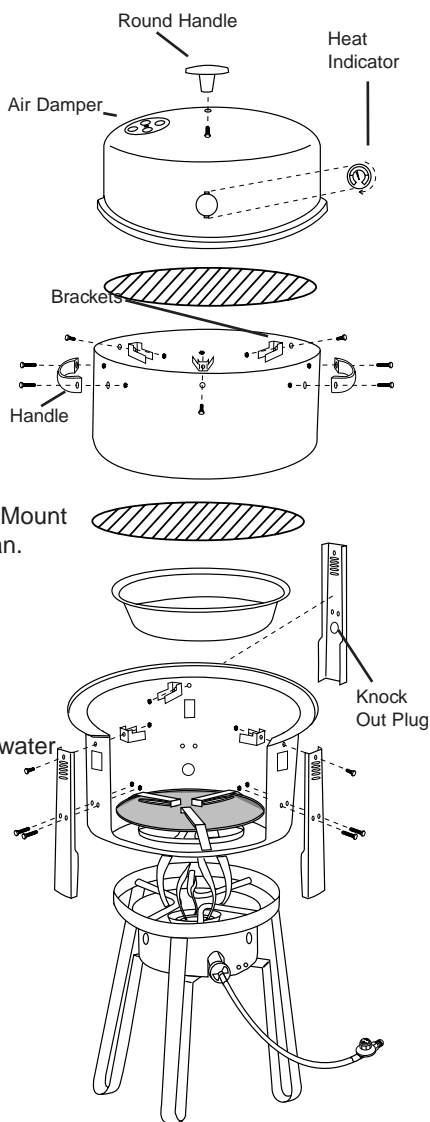

## FRYING AND BOILING

### SCREAMING BUFFALO WINGS

- 1 gallon vegetable oil
- 24 chicken wings
- 1 small bottle of hot sauce (your choice)
- 1/2 teaspoon of salt
- 1/4 teaspoon of pepper
- 1/4 cup butter or margarine, melted
- 1 teaspoon white vinegar
- Pinch of garlic salt
- Celery sticks
- Blue cheese dressing

Thaw wings (if frozen) and place into basket. Pour 1 gallon of oil into 10 1/2-quart pot and bring temperature to 350°F. Slowly place basket of wings into oil and cook 8 to 12 minutes. Remove and drain wings and pour into bowl. Mix hot sauce with melted margarine and garlic salt. Pour over wings, mix well and serve.

### CAJUN-COATED FISH

- 4 fresh or frozen catfish, red snapper or fillets, 1/2- to 3/4-inch thick (1 to 1 1/4 lbs.)
- 1/4 cup all-purpose flour
- 1/4 cup yellow cornmeal
- 1 teaspoon dried basil, crushed
- 1 teaspoon onion powder
- 1/2 to 1 teaspoon ground red pepper
- 1/2 teaspoon garlic salt
- 1/2 teaspoon ground white pepper
- 1/2 teaspoon dried thyme, crushed
- 1/3 teaspoon ground black pepper
- 1/4 teaspoon ground sage
- 1/4 cup margarine or butter

Thaw fish, if frozen. In a shallow mixing bowl, combine flour, cornmeal, basil, onion powder, red pepper, garlic salt, white pepper, thyme, black pepper and sage. Coat both sides of the fish with the flour mixture. Cook in 1 gallon of oil at 350°F for 3 to 4 minutes.

## COOKING TIPS

### CHARCOAL

- Always wear cooking gloves when recharging. Use long cooking tongs when adding charcoal. Stir up ashes.

**NOTE: NEVER ADD LIGHTER FLUID TO CHARCOAL. NEVER USE CHARCOAL AS AN INDICATOR.**

## GRILLING RECIPES

### CARIBBEAN FLAVOR CHICKEN

1 teaspoon salt  
1 clove garlic, peeled, plus 2 cloves, minced  
1 1/2 teaspoons dried leaf oregano  
1/4 teaspoon paprika  
1 tablespoon lemon or lime juice  
8 chicken pieces (breasts, thighs, drum sticks)  
3 tablespoons oil  
1 small onion, minced  
1/3 catsup  
1/3 cup cider vinegar

With a mortar and pestle or with back of spoon against bowl, mash salt with peeled garlic to make a paste. Work in 1/2 teaspoon oregano, paprika and lemon juice. Rub this mixture over the chicken. Brush with 1 tablespoon. Place chicken over hot coals and grill, turning every 7 to 8 minutes, until done. Meanwhile, sauté a few seconds. Stir in catsup, vinegar and remaining oregano, and simmer 15 minutes. When chicken is done, brush with sauce and grill 5 minutes longer. Pile onto a warm platter and serve remaining sauce at table. Fried plantain or grill-baked bananas or saffron rice go well with this.

### ORANGE-GLAZED LEG OF LAMB

1 butter-fly leg of lamb (4-7 lbs.)  
3 tablespoons of teriyaki sauce  
1/4 cup of orange juice  
1 clove garlic, finely minced  
1/4 cup orange marmalade  
Pour mixture of teriyaki juice, and garlic over the lamb; cover and refrigerate for 4 to 6 hours, basting occasionally. Grill the lamb 4 to 6 inches from the heat for 20 to 25 minutes on each side, turning often. Baste with teriyaki mixture, adding marmalade during the last half hour of cooking.

### FILLET WITH MUSHROOM SAUCE

Beef fillet, about 4 1/2 pounds  
1 1/2 cups red wine  
1/4 cup oil  
1/4 cup minced onion  
1 tbsp. herbs deProvence or other herbs  
Mushroom sauce

Buy prime-grade fillet, if possible, and trim well. Fold and tie the tail to the meat to form a roast of uniform thickness (or have butcher do it for you). Place meat in a plastic bag. Mix wine, oil, onion and herbs. Pour over the meat; close bag tightly and turn it to coat meat with marinade. Place bag in dish and marinate meat 2 hours at room temperature or overnight in refrigerator. Drain meat, reserving marinade. Grill meat 4 inches above hot coals, turning to brown all sides. This takes about 10 minutes of undivided attention so you can put out any flash fires. Add damp hickory chips or small hickory sticks. Move meat to edge of grill or cover grill and cook 15 to 20 minutes longer for rare, 20 to 25 minutes for medium rare. Slice and serve with mushroom sauce.

### GRILLED FLANK STEAK

1 1/2 lbs. flank steak  
Marinate in:  
1/4 cup Worcestershire sauce  
1/3 soy sauce  
1tsp. dried, ground ginger or freshly chopped ginger and the juice of 1 lemon  
Place steak in shallow glass casserole dish and pour marinade over top. Let marinate at least 3 hours, turning every hour or so. Remove from smoker and place on grill for 3 to 4 minutes on each side. Slice diagonally and serve.

## COOKING TIPS

### CHARCOAL

- You may need to add additional charcoal during cooking to increase the temperature. Follow the instructions and warnings in the charcoal smoking and grilling section.
- Dry, hard woods will burn hotter than charcoal so you may want to increase the ratio of wood to charcoal.

## REGULATOR CONTROL GAS CYLINDER VALVE

CLOCKWISE

COUNTER  
CLOCKWISE



Before use,  
valve ON and  
first, then th



CLOCKWISE

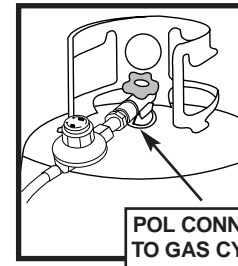

**POL CONNECTION  
TO GAS CYLINDER**

USE A 7/8" WRENCH TO  
TIGHTEN. DO NOT HAND  
TIGHTEN OR USE PLIERS  
NOTE:

If unit is supplied with a type 1  
connection hand tighten ONLY

## QUICK

- Please use extreme caution when adding or removing food from the smoker unit.
- For the taste of charcoal and the convenience of gas, add four to five briquettes to your flame. DO NOT use Quick Start or any charcoal starter with lighter fluid at any time during the smoking process.

**In a low heat setting, DO NOT allow flame to burn less than 5 inches high.**

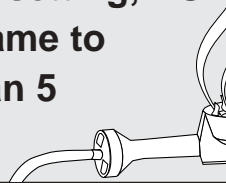

## SOAPY WATER TEST PROCEDURES

- The soapy water test must be performed each time the tank is connected to your appliance.
- The soapy water test must be performed outdoors in a well ventilated area.
- When performing the Soapy Water Test always keep appliance away from open flames, sparks or lit cigarettes.
- This appliance is designed to operate on propane gas only. This product will not operate on natural gas.
- **NEVER** use an open flame to test for gas leaks.

### PROCEDURE:

1. Remove complete smoker and any cookware from your cooker stand.
2. Turn regulator to OFF position; turn gas cylinder valve to OFF position.
3. Prepare your soapy water solution by combining 1 part dish washing liquid with 3 parts water to test for the possibility of any gas leaks in the hose or connections. Apply soapy water solution to gas cylinder fitting.
4. Turn gas cylinder valve on (regulator valve is in OFF position) and observe cylinder fitting for bubbles. Do not leave gas on for more than 12 seconds. If bubbles appear, stop, turn gas cylinder OFF and retighten the fitting connecting to the cylinder by turning counter clockwise. Repeat test.
5. With the regulator control valve in the "OFF" position, turn ON the gas cylinder valve. Open the regulator control valve 1 full turn and check for bubbles at control valve, along the entire length of hose and at the connection to the burner. Do not leave gas on for more than 12 seconds. If soapy mixture starts bubbling, gas is leaking through the connection or hose. Turn the regulator valve OFF and then the gas cylinder OFF and retighten the connection that is leaking gas.
6. After test is complete, and there are no leaks, wait a minimum of 5 minutes for gas fumes to dissipate before lighting.

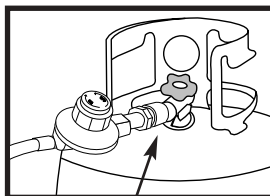

GAS CYLINDER VALVE AND REGULATOR POL

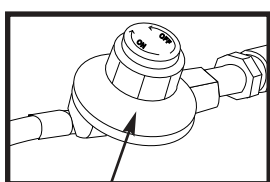

REGULATOR VALVE

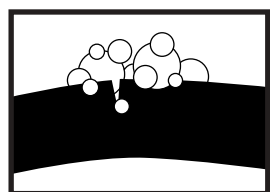

SOAPY WATER BUBBLES

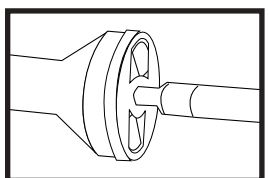

BURNER/HOSE CONNECTION

## STOP

**DURING ANY PORTION OF THE SOAPY WATER TEST BUBBLES CONTINUE TO APPEAR, STOP, DO NOT USE AND CONTACT MASTERBUILT HOTLINE AT (800) 489-1581. WE WILL CORRECT THE PROBLEM.**

### SMOKED SHRIMP KEBAB

#### with GARLIC COCKTAIL SAUCE

36 large shrimp, peeled and deveined (tails left intact)

2 large red bell peppers, cut into 1-inch pieces

Commercial Italian dressing

Garlic cocktail sauce

Alternately thread shrimp and red pepper pieces onto 12 wooden skewers. Place in a shallow container and drizzle with Italian dressing. Cover and refrigerate at least 2 hours. Drain sauce from kabobs. Place shrimp kabob on a cooking grate. Cover with smoker dome and cook 15 minutes or until shrimp are pink and firm to touch. Serve warm with garlic cocktail sauce.

### BAKED POTATOES & CORN ON THE COB

Corn can be wrapped in foil or soaked in water and smoked right in the husk. Potatoes can be wrapped in foil or cooking nails may be used.

### SAUSAGE

The Kolbase (Polish sausage), Italian Sausage or any smoked sausage cooks great! Requires about 5 lbs. of hardwood briquette, hickory, pan of water. Let smoke for about 1 or 1 1/2 hours. Sausage makes excellent kebabs.

### MUSHROOMS, CAULIFLOWER or SQUASH

Your favorite vegetables can be smoked for a cook-out flavor. By smoking your vegetables, you also seal in the nutrients and vitamins which can be lost through average cooking. After wrapping vegetables in foil add Italian dressing, salt, pepper, bell peppers and onions.

## COOKING TIPS

### WATER BOWL

- Line water bowl with aluminum foil before use to clean and help your water bowl last longer.
- If your water level is low, add more water to the side and pour water slowly through the burner to avoid splash or overflow water.

## SMOKING RECIPES

### SMOKE ROASTED ASPARAGUS IN GARLIC

- 1 small onion, thinly sliced
- 1 1/2 pounds fresh asparagus, trimmed
- 2 tablespoons of butter or margarine
- 4 cloves garlic, thinly sliced
- 2 tablespoons lemon juice
- 1/4 teaspoon of pepper

Line the bottom of a shallow 1-quart gratin dish with onion slices; arrange asparagus over onion slices; set aside.

Melt butter in a small skillet over low heat; add garlic and cook until tender. Remove from heat and stir in lemon juice, salt and pepper. Drizzle garlic mixture evenly over asparagus. (Do not cover dish). Place dish in top cooking grate of smoker. Cover with smoker lid and cook 1 hour or until crisp and tender.

### BARBECUE SAUCE

- 3 8-oz. cans tomato sauce
- 1 small bottle Worcestershire sauce
- 1/4 tsp. garlic powder
- 1/2 lb. butter
- 1/2 cup brown sugar
- 1tsp. dry mustard
- 2 tbsps. vinegar
- 2 tbsps. lemon juice
- 1/8 tsp. red pepper
- 1/2 tsp. salt
- 1/2 tsp. seasoned pepper

Simmer all ingredients for 30 minutes.

For some recipes, you may add some of the ingredients (juices) to the water bowl; additional cooking time will need to be added. See cooking chart.

## COOKING TIPS

### WOOD

- A variety of wood chunks may be used. For example: mesquite, hickory, pecan, apple or cherry. Do not use resinous woods such as pine.
- Use chunks around 3" to 4" long and approximately 1/2" or 1" thick. Soak wood in water, wrap in foil and pierce holes in foil. You will need approximately 3 chunks or sticks.

### SMOKED HAM

- 1 10-lb. precooked ham
- 1/4 cup crushed pineapple
- 1/2 cup honey
- 2 tablespoons soy sauce (Dale sauce may be substituted, if available)

Remove fat from ham. Score top of ham about 1/4" deep. Put water bowl under middle grill rack. Do not add any liquid to water bowl (dry smoke). Place ham on middle grill rack with scored side up. Place 2-3 wood chunks on charcoal, or bottom of base pan. Baste top of ham every hour with mixture. Cook 4 hours or until 140°F inside ham.

### SMOKED TURKEY

- 6 to 8 lb. turkey
- 2 cups of hickory or apple chips

Soak the chips in water for at least one hour. This will create smoke, smoldering instead of burning them. Rinse the turkey and dry well. Fold the wings close to the body and tie or skewer. Close both openings with skewers and tie the legs together tightly.

Secure with holding forks. Place on the rack over low, indirect heat with the water pan underneath. Throw half of the drained wood chips on the hot coals. Cook for approximately 2 1/2 hours. Be sure to keep the lid down and the smoke in. Let rest 10 minutes before carving.

## How To Use Your Unit...

### GAS SMOKING

1. For gas smoking add desired amount of wood to the top of flame disk.
2. Fill water bowl with your favorite marinade or water. Do not overfill the water bowl. (Line your water bowl with aluminum foil for easier clean up.)
3. Place grill rack on top of water bowl and add food. Place upper body on base pan. Add grill rack, food. For dry smoking Do Not use water or marinade.
4. To light gas cooker use a long match or striker through lighting hole on the side of cook. Turn red knob on regulator slowly until burner lights. Adjust burner flame to desired temperature and cover with dome lid.

(Smoker will Heat Up Quickly)

5. Open the smoker access door carefully when adding charcoal or wood chips to flame disk. Use extreme caution because the door is hot.

\*Never move your smoker while it is in use and allow it to cool completely before moving or handling.

**SMOKE IS ONLY GENERATED WHEN WOOD IS PLACED ON FLAME DISK.**

Gas Grilling

### GAS GRILLING

1. Remove water bowl and smoker body from unit.
2. Use the same lighting instructions as smoking.



### **SEASONING YOUR Grill / Smoker & Cooker**

To season your unit, light the burner. Bring the temperature up and maintain 200°.

Place two or three wood chunks on the flame disk and operate the smoker with no food or water for two to four hours before using it.

This allows the unit to settle and removes that new smell.

**\*\*\*\*\*IMPORTANT\*\*\*\*\***

**OUTDOOR USE ONLY / NEVER**

## GAS BOILING AND FRYING INSTRUCTIONS

1. Remove your smoker from cooker stand.
2. Check the regulator control valve to be certain it is in the OFF position.
3. Place pot on stand and fill with desired amount of water or oil. **DO NOT** use more than 1 gallon of oil or 2 gallons of water in a 10.5 qt. pot. Reduce the amount of oil or water when using smaller cookware. This will help avoid dangerous boil overs. **DO NOT** place your empty pot over the open flame; it will damage the pot.
4. Follow the gas lighting instructions listed under Gas Smoking Instructions on
5. Bring your water or oil to the desired temperature; lower basket into pot slowly to avoid boil overs. **OIL TEMPERATURE SHOULD NEVER EXCEED 350°F!** We also recommend using a thermometer for frying.
6. After use, first turn regulator control valve OFF, then the gas cylinder OFF. Always allow your gas stove, pot and contents to cool completely before touching, moving or storing.

**NOTE:** If it begins to rain while you are frying, turn the regulator to OFF position, then the gas cylinder to OFF position and cover pot with aluminum foil or lid. **DO NOT** move cooker stand or pot. **DO NOT** move indoors, under cover or overhang of house or building!

**In a low heat setting, do not allow flame to burn less than 5 inches high.**

**DO NOT use pots larger than 14 and 1/2 inches in diameter on the cooker stand. If you are using pots purchased from MASTERBUILT, it is safe to use the 24- and 37-qt. pots. Pot extension arms must be used on the cooker stand if you plan to use the 55-, 80-, 100- and 120-qt. pots.**

**Smokers are sold with and without pot and basket.**

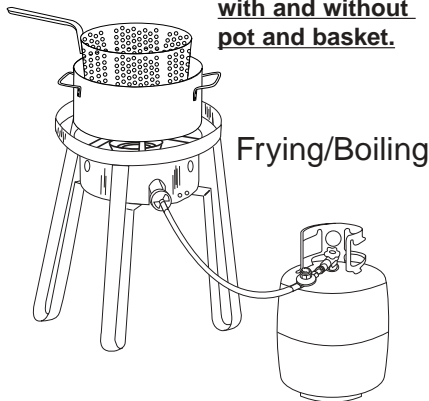

**Never leave appliance unattended while it is in use and until appliance, oil or water have cooled completely.**

1. When cooking with oil or grease, do not exceed 350° F (177° Celsius). One gallon of oil can reach 350° in 7 to 10 minutes, use a thermometer to check temperature. When cooker is in operation NEVER LEAVE UNATTENDED, oil will heat up quickly and ignite at 550° to 700°. (One gallon of oil Max in 10qt to 12qt pots, Two gallons of oil Max in 26qt pots)
2. Do not store extra cooking oil in the vicinity of this cooking appliance.
3. Do not store or use gasoline or other flammable vapors and liquids in the vicinity of this or any other cooking appliances.
4. An LP cylinder not connected for use shall not be stored within 10 feet (6m) of this or any other cooking appliance.
5. Keep LP gas cylinder up wind when in use.

## Cooking Chart for Gas

BEEF	Quantity	Heat Setting	Char (Amount)
Whole rump roast	3 - 4 lbs.	200°	5 - 7 II
Pot roast (arm, chuck, blade, top, bottom round)	4 - 5 lbs.	200°	7 - 8 II
Short ribs	3 - 4 lbs. 4 - 6 lbs.	200° 200°	5 - 7 II 7 - 8 II
Brisket	3 - 4 lbs.	200°	7 - 8 II
Steak	5 - 7 lbs.	200°	8 - 10 II
PORK			
Loin roast, bone in	3 - 4 lbs. 5 - 7 lbs.	200° 200°	8 lbs. 8 lbs.
Loin roast, boneless	3 - 5 lbs.	200°	10 lbs.
Spareribs	4 - 6 lbs. 7 - 10 lbs.	200°	8 - 10 II 10 lbs.
Country Style back ribs	4 - 6 lbs.	200°	7 - 10 II
Pork Chops 1-inch thick	6 - 10 chops	200°	5 - 7 II
HAMS			
Fully-cooked	5 - 7 lbs.	200°	7 - 8 II
Pre-cooked	8 - 10 lbs.		8 - 10 II
Fresh	16 - 18 lbs.		10 lbs.
POULTRY			
Chicken(2 whole)	2-3 lbs. each	200°	5 - 7 II
(4 whole)	2-3 lbs. each		8 - 10 II
Hen (one)	5 lbs.		10-12 II
Turkey	8 - 10 lbs. 11 - 13 lbs. 14 - 16 lbs.	200°	8 lbs. 8 - 10 II 10-12 II
LEG OF LAMB	5 - 7 lbs.	200°	8 lbs.
VEAL RUMP ROAST	3 - 5 lbs.	200°	5 - 7 II
FISH & SEAFOOD			
Whole fish	4 - 6 lbs.	200°	7 lbs.
Fillets	Full grid		5 lbs.
Whole salmon	6 - 7 lbs.		10 lbs.
Shrimp, crab legs, lobster, clams	Full grid	200°	5 lbs.
WILD GAME			
cornish hens	4 hens	200°	5 - 7 II
Small game birds (Quail, dove, etc.)	12 - 16 birds		7 - 10 II
Large game bird (Pheasant, duck, goose, etc.)	5 - 7 lbs.	200°	8 - 10 II

- When the outside temperature is cooler than and the altitude is above 3,500 feet, we suggest adding more cooking time. (If you are not sure meal is cooked, use a meat thermometer to test meat.)
- Do not lift your smoker lid during the smoking process to check food. This will extend your cooking time due to heat escape.
- If you are using only 1 grill rack, use the upper rack for better results. If you need to use both racks place the meat that requires the least cooking time on the top grill.

**OUTDOOR USE ONLY / NEVER**