

# Panasonic®

## Room Air Conditioner **OPERATING INSTRUCTIONS**

Before using your air conditioner, please read this operating instructions carefully and keep it for future reference.



### COOLING MODEL :-

Indoor  
**CS-C9CKPG**  
**CS-C12CKPG**

Outdoor  
**CU-C9CKP6G**  
**CU-C12CKP6G**

### HEAT-PUMP MODEL :-

Indoor  
**CS-A9CKPG**  
**CS-A12CKPG**

Outdoor  
**CU-A9CKP6G**  
**CU-A12CKP6G**

**ENGLISH ..... P. 1 – P. 11**  
**ESPAÑOL ..... P. 12 – P. 22**

Please register your product at  
[www.panasonic.com/register](http://www.panasonic.com/register)

For assistance, please call; (866)-292-7292, for  
Hawaii residents call (808)-488-7779.

Thank you for purchasing our Panasonic Room Air Conditioner.

## CONTENTS

- ▶ **Features** ..... 1
- ▶ **Safety Precautions** ..... 2
  - Installation Precautions
  - Operation Precautions
- ▶ **Name of Each Part** ..... 3~4
  - Indoor Unit
  - Outdoor Unit
  - Accessories
  - Remote Control
- ▶ **Preparation Before Operation** ..... 5
  - Indoor Unit
  - Remote Control
- ▶ **How to Operate** ..... 5~6
- ▶ **Setting the Timer** ..... 7
- ▶ **Convenience Operation** ..... 7
  - Powerful Mode Operation
  - Economy Mode Operation
  - Quiet Mode Operation
- ▶ **Care and Maintenance** ..... 8
  - Cleaning the Indoor Unit and Remote Control
  - Cleaning the Air Filter
  - Cleaning the Front Panel
  - Air Purifying Filters
  - Pre-season Inspection
  - When the Air Conditioner is Not Used for an Extended Period of Time
  - Recommended Inspection
- ▶ **Helpful Information** ..... 9
- ▶ **Energy Saving and Operation Hints** ..... 9
- ▶ **Troubleshooting** ..... 10
  - Normal Operation
  - Abnormal Operation
  - Call the Dealer Immediately
- ▶ **Product Specification and Reference** ..... 11

**Note:**

Before using your air conditioner, please read this operating instructions carefully and keep it for future reference.

## FEATURES

- **Illuminating Button**  
For your convenience to operate the unit in the dark.  
(Refer page 4)
- **Automatic Operation**  
Sense indoor temperature to select the optimum mode.  
(Refer page 5)
- **Quiet Mode**  
To provide quiet operation.  
(Refer page 7)
- **Economy Mode**  
To reduce electrical power consumption.  
(Refer page 7)
- **Powerful Mode**  
Reaches the desired room temperature quickly.  
(Refer page 7)
- **Removable Front Panel**  
For quick and easy cleaning (washable).  
(Refer page 8)
- **Air Purifying Filter**  
This new filter helps trap small airborne particles such as dust, pollen and tobacco smoke.  
(Refer page 8)
- **Solar Refreshing Deodorizing Filter**  
Used to remove unpleasant odor and deodorize the air in the room.  
(Refer page 8)
- **Auto Restart Control**  
Restart the unit automatically after power failure.  
(Refer page 9)

## Warning

- 1) Operate your air conditioner from a stable 115 volts AC supply.
- 2) Use a 15 Amps (CS-C9CKPG/CU-C9CKP6G, CS-A9CKPG/CU-A9CKP6G) or 20 Amps (CS-C12CKPG/CU-C12CKP6G, CS-A12CKPG/CU-A12CKP6G) time delay fuse or a circuit breaker.
- 3) Disconnect from the main before servicing this appliance.
- 4) Do not repair by yourself.  
In case of malfunction of this appliance, do not repair by yourself. Contact the sales dealer or service dealer for a repair.
- 5) Turn off the power (Isolation from main power supply). Switch off the breaker, or switch off the power disconnecting means to isolate the equipment from the main power supply in case of an emergency.

POWER SUPPLY	
Time Delay Fuse:  15 Amps : CS-C9CKPG/ CU-C9CKP6G, CS-A9CKPG/ CU-A9CKP6G  20 Amps : CS-C12CKPG/ CU-C12CKP6G, CS-A12CKPG/ CU-A12CKP6G	Rated Volts:  115 V

## SAFETY PRECAUTIONS

Before operating, please read the following "Safety Precautions" carefully.

- To prevent personal injury, injury to others and property damage, the following instructions must be followed.
- Incorrect operation due to failure to follow instructions will cause harm or damage, the seriousness of which is classified as follow:



**Warning**

This sign warns of death or serious injury.



**Caution**

This sign warns of damage to property.

- The instructions to be followed are classified by the following symbols:



This symbol (with a white background) denotes an action that is PROHIBITED.



These symbols (with a black background) denote actions that are COMPULSORY.

### ■ Installation Precautions



**Warning**

- **Do not install, remove and reinstall the unit by yourself.**  
Improper installation will cause leakage, electric shock or fire. Please engage an authorized dealer or specialist for the installation work.



**Caution**



- **This room air conditioner must be earthed.**  
Improper grounding could cause electric shock.

- **Ensure that the drainage piping is connected properly.**  
Otherwise, water will leak out.



- **Do not install the unit in a potentially explosive atmosphere.**  
Gas leak near the unit could cause fire.

### ■ Operation Precautions



**Warning**

This sign warns of death or serious injury.



- Do not operate with wet hands.
- Do not insert finger or other objects into the indoor or outdoor units.
- Do not expose directly to cold air for a long period of time.



- Use specified power cord.



- If abnormal condition (burnt smell, etc.) occurs, switch off the power supply.



**Caution**

This sign warns of injury.



- Do not wash the unit with water.
- Do not use for other purposes such as preservation.
- Do not use any combustible equipment at airflow direction.
- Do not sit or place anything on the outdoor unit.



- Switch off the power supply before cleaning.
- Ventilate the room regularly.
- Pay attention as to whether the installation rack is damaged after a long period of usage.



- Switch off the power supply if the unit is not used for a long period.

## NAME OF EACH PART

### ■ Indoor Unit

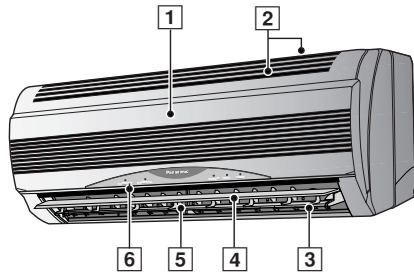

- 1 Front Panel
- 2 Air Intake Vent
- 3 Air Outlet Vent
- 4 Vertical Airflow Direction Louver
- 5 Horizontal Airflow Direction Louver (manually adjusted)
- 6 Indicator Panel

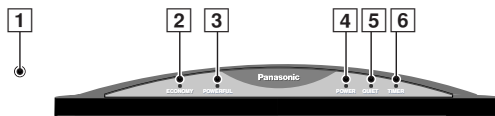

- 1 Auto Operation Button (when the front panel is opened)
- 2 Economy Mode Indicator – GREEN
- 3 Powerful Mode Indicator – ORANGE
- 4 Power Indicator – GREEN
- 5 Quiet Mode Indicator – ORANGE
- 6 Timer Mode Indicator – ORANGE

### ● Indoor Unit (when the front panel is opened)

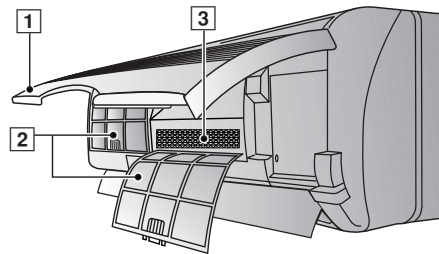

- 1 Front Panel
- 2 Air Filters
- 3 Air Purifying Filter

### ■ Outdoor Unit

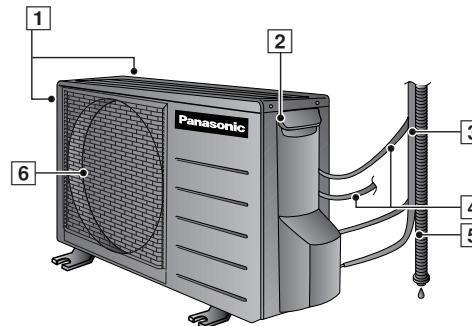

- 1 Air Intake Vents
- 2 Ground Terminal (Inside cover)
- 3 Piping
- 4 Conduit
- 5 Drain Hose
- 6 Air Outlet Vents

### ■ Accessories

#### ● Remote Control



#### ● Remote Control Holder

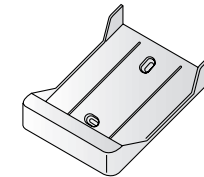

#### ● Two RO3 (AAA) dry-cell batteries or equivalent

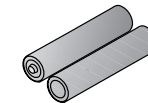

#### ● Air Purifying Filter

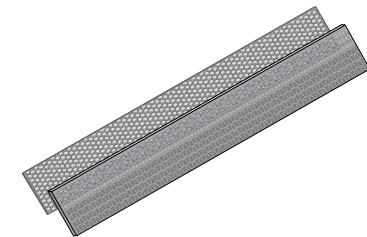

(Air Purifying Filter)

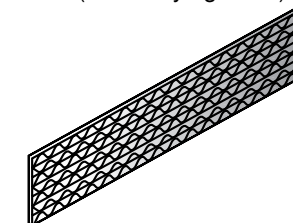

(Solar Refreshing Deodorizing Filter)

## NAME OF EACH PART

### ■ Remote Control

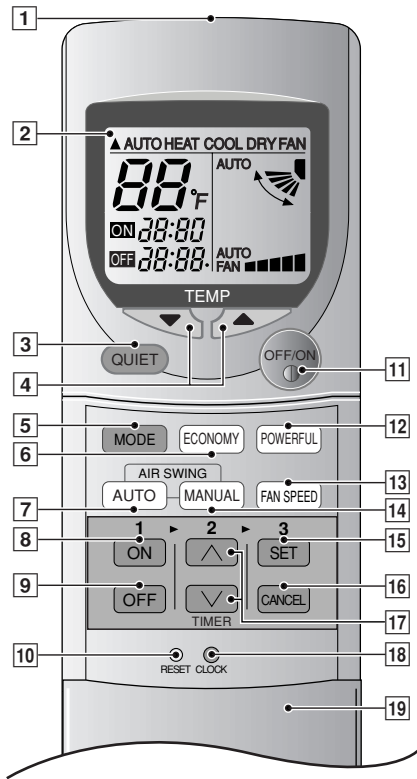

#### ● Remote Control Signal

- Make sure it is not obstructed.
- Maximum distance : 10 m (32.8 ft.).
- Signal received sound :  
One short beep or one long beep.

#### ● Notes for Remote Control

- Do not throw or drop.
- Do not get it wet.
- Certain types of fluorescent lamps may affect signal reception. Consult your dealer.

- 1 Signal Transmitter
- 2 Operation Display
- 3 Quiet Mode Operation Button
- 4 Room Temperature Setting Button (Illuminating button)
- 5 Operation Mode Selection Button
- 6 Economy Mode Operation Button
- 7 Auto Airflow Direction Button
- 8 ON-Timer Button
- 9 OFF-Timer Button
- 10 Reset Point  
(Press with fine-tipped object to clear the memory)
- 11 OFF/ON Button  
(Illuminating button)
- 12 Powerful Mode Operation Button
- 13 Fan Speed Selection Button
- 14 Manual Airflow Direction Selection Button
- 15 Timer Set Button
- 16 Timer Cancellation Button
- 17 Time-Setting Button
- 18 Clock Button
- 19 Remote Control Cover

#### ● How to Insert the Batteries

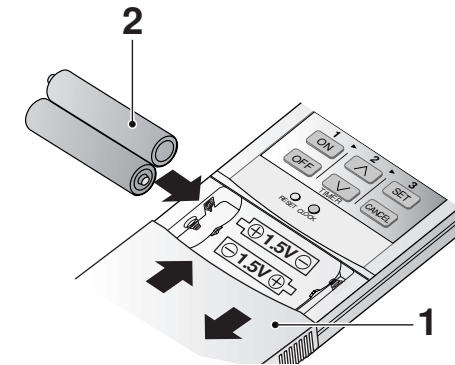

**1 Slide down the remote control cover completely to remove it.**

#### **2 Insert the batteries**

- Be sure the direction is correct
- 12:00 on display - flashing
- Set the current time (CLOCK) immediately to prevent battery exhaustion.

**3 Re-install the remote control cover by inserting it in the side grooves and pushing inward.**

#### ● About the batteries

- Can be used for approximately one year.

#### ● Observe the following when replacing the batteries

- Replace with new batteries of the same type.
- Do not use rechargeable batteries (Ni-Cd).
- Remove the batteries if the unit is not going to be used for a long period.

## PREPARATION BEFORE OPERATION

### Indoor Unit

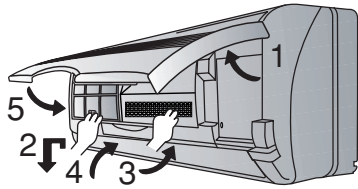

- 1 Open the front panel
- 2 Remove the air filters
- 3 Fit the air purifying filters in place
- 4 Insert the air filters
- 5 Close the front panel

### Remote Control – To set the current time

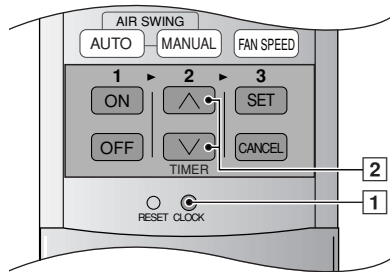

- 1 Press **1**.
  - 2 Then press **2** to increase or decrease the time.
  - 3 Press **1** again.
- Set time on display will light up.

## HOW TO OPERATE

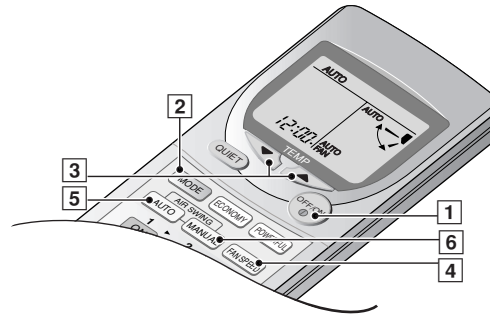

### To start the operation

- Press **1**.
- POWER indicator (green) on the indoor unit will light up.
- To stop, press once more.

### Setting Mode

- Press **2** to select:-

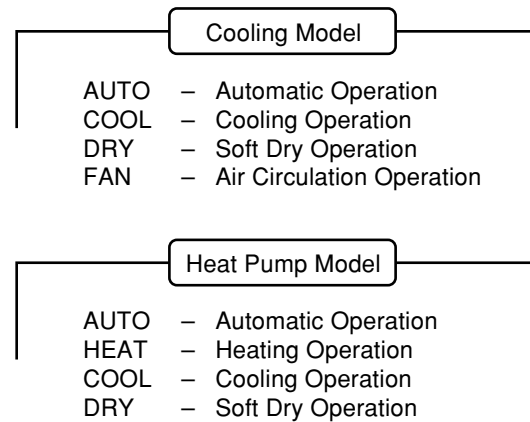

### Setting Temperature

- Press **3** to increase or decrease the temperature.
- The temperature can be set between 60°F ~ 86°F.
- Recommended temperature:

Cooling Model	Heat Pump Model
COOL → 75°F ~ 78°F	COOL → 75°F ~ 78°F
DRY → 2°F ~ 4°F lower than the room temperature	DRY → 2°F ~ 4°F lower than the room temperature
	HEAT → 68°F ~ 75°F

- During **AUTO** Operation, press **3** to select:-



- Operation with 4°F higher than the standard temperature.



- Operation with the standard temperature.



- Operation with 4°F lower than the standard temperature.

### Standard Temperature

Indoor temperature	Cooling Model	
	Operation	Standard temperature
73°F	Cooling	77°F
	Soft Dry	72°F

- Once the Automatic Operation is selected, the indoor temperature sensor operates automatically to select the desired operation mode with Cooling or Soft Dry.
- After the operation mode has been selected, the mode does not change.

Indoor temperature	Heat Pump Model	
	Operation	Standard temperature
73°F 68°F	Cooling	77°F
	Soft Dry	72°F
	Heating	70°F

- At the beginning of the automatic operation, Heating, Cooling or Soft Dry is automatically selected according to the indoor temperature.
- The operation mode changes every hour, when necessary.

■ **Setting the Fan Speed**

• Press [4] to select:-

- FAN ■ — Low Fan Speed
- FAN ■■■ — Medium Fan Speed
- FAN ■■■■ — High Fan Speed
- AUTO
- FAN — Automatic Fan Speed

The speed of the indoor fan is adjusted automatically according to the operation. The indoor fan stops occasionally during cooling operation.

■ **Setting the Vertical Airflow Direction**

• Press [5] or [6] to select:-

**Cooling Model**

**COOL / DRY Operation**  
[AUTO]

Swing up/down  
Automatically

**MANUAL**  
Five stages of adjustment can be made between 14 ~ 36 angle.

**FAN Operation**  
[AUTO]

Move up/down  
Automatically

**MANUAL**  
Five stages of adjustment can be made between 0 ~ 61 angle.

**Heat Pump Model**

**COOL / DRY Operation**  
[AUTO]

Swing up/down  
Automatically

**MANUAL**  
Five stages of adjustment can be made between 14 ~ 36 angle.

**HEAT Operation**  
[AUTO]

- When the discharge air temperature is low such as at the start of heating operation, the air blows in a horizontal direction. As the temperature rises, the hot air blows in a downward direction.
- To stop this operation, press MANUAL.

**MANUAL**  
Five stages of adjustment can be made between 0 ~ 61 angle.

■ **Setting the Horizontal Airflow Direction**

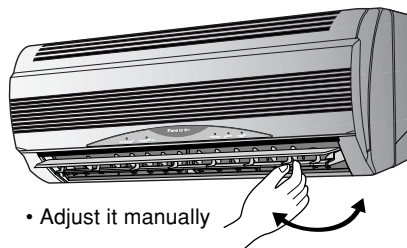

• Adjust it manually

● **Use this air conditioner under the following conditions:**

**Cooling Model**

(Unit in °F)

DBT: Dry Bulb Temp WBT: Wet Bulb Temp	Indoor		Outdoor	
	DBT	WBT	DBT	WBT
Maximum Temperature	89.6	73.4	109.4	78.8
Minimum Temperature	60.8	51.8	60.8	51.8

**Heat Pump Model**

(Unit in °F)

DBT: Dry Bulb Temp WBT: Wet Bulb Temp	Indoor		Outdoor	
	DBT	WBT	DBT	WBT
Maximum Temperature-Cooling (Maximum Temperature-Heating)	89.6 (86)	73.4 (-)	109.4 (75.2)	78.8 (64.4)
Minimum Temperature-Cooling (Minimum Temperature-Heating)	60.8 (60.8)	51.8 (-)	60.8 (23)	51.8 (21.2)

● **Notes**

- If the unit is not going to be used for an extended period of time, turn off the main power supply. If it is left at the ON position, approximately 2.5 W of electricity will be used even if the indoor unit has been turned off with the remote control.
- If operation is stopped, then restart immediately, the unit will resume operation only after 3 minutes.

● **Operation Details**

**COOL – Cooling Operation**

- To set the room temperature at your preference cooling comfort.

**AUTO – Automatic Operation**

- Sense indoor temperature to select the optimum mode.
- Temperature is not displayed on the remote control during AUTO operation.

**DRY – Soft Dry Operation**

- A very gentle Cooling Operation, prior to dehumidification. It does not lower the room temperature.
- During Soft Dry operation, the indoor fan operates at Low fan speed.

**HEAT – Heating Operation**

(for Heat Pump Model only)

- Heat is obtained from outdoor air to warm up the room. When the outdoor ambient air temperature falls, the heating capacity of the unit might be reduced.
- Defrosting Operation  
Depending on the outdoor temperature, the operation occasionally stops to melt the frost on the outdoor unit.

**FAN – Air Circulation Operation**

(for Cooling Model only)

- When the room temperature reaches the set temperature, operation commences at Low airflow volume. It stops when the room temperature drops to 4°F below the set temperature. (It is useful when using a heater).
- Hi fan speed will not operate when using the air circulation Fan mode.

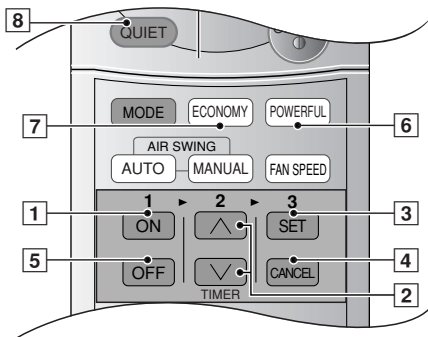

## SETTING THE TIMER

Ensure that the current time is correct before setting the timer. The timer cannot be set if the time display is flashing.

### ■ ON-TIMER Operation

- To start the air conditioner operation automatically.
- Press [1] to set the operation.
- Press [2] to increase or decrease the time.
- Then press [3].
- To cancel this operation, press [4].

### ■ OFF-TIMER Operation

- To stop the air conditioner operation automatically.
- Press [5] to set the operation.
- Press [2] to increase or decrease the time.
- Then press [3].
- To cancel this operation, press [4].

### ● Timer Mode Operation Details

- When the ON-Timer is set, operation will start before the actual set time. This is to enable the room temperature reaches the set temperature at the set time.

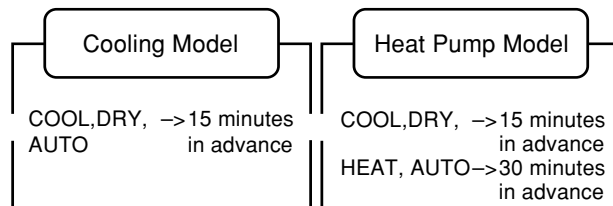

- Once the ON/OFF Timer is set, operation will start/stop at the set time everyday.
- The current time is not displayed when the timers are set.
- When both timers are used together, the TIMER mode indicator on the indoor unit remains lit even when the operation is stopped by the OFF-TIMER.

## CONVENIENCE OPERATION

### ■ Powerful Mode Operation

To obtain the set temperature quickly.

- Press [6].
- ✗ Powerful mode indicator (orange) on the indoor unit will light up.
- ✗ Powerful mode will operate for 15 minutes only.
- To cancel this operation, press once more.

### ■ Economy Mode Operation

To save electrical power consumption.

Please use this mode when the room has reached your desired temperature.

- Press [7].
- ✗ Economy mode indicator (green) on the indoor unit will light up.
- Press once more to cancel this operation.

### ● Economy/Powerful Mode Operation Details

- Economy and Powerful operation cannot be selected simultaneously.
- The changes of the temperature and airflow volume are automatic.
- The remote control display remains unchanged.
- If operation mode button is pressed, economy or powerful operation will be cancelled.
- During **FAN** – Air circulation operation, the powerful and economy operation are not available. (for Cooling Model only)

Economy Mode Operation	Temperature	Airflow volume
COOL / DRY	1°F higher than set temp.	Super Low
HEAT (for Heat Pump model only)	1°F lower than set temp.	Automatic

Powerful Mode Operation	Temperature	Airflow volume
COOL / DRY	5°F lower than set temp.	Super High
HEAT (for Heat Pump model only)	5°F higher than set temp.	Automatic

### ■ Quiet Mode Operation

To provide quiet operation.

- Press [8].
- ✗ Quiet mode indicator on the indoor unit will light up.
- To cancel this operation, press once more.

### ● Operation Details

- Air flow sound will reduce during operation.



## CARE AND MAINTENANCE

### ■ Cleaning the Indoor Unit and Remote Control

- Wipe gently with a soft, dry cloth.
- Do not use water hotter than 104°F or polishing fluid to clean the unit.

### ■ Cleaning the Air Filter

(Recommendation:- If the unit is operated in a dusty environment, clean the filters every two weeks. Continuous use of this dirty filters will reduce cooling or heating efficiency)

- 1 Remove dirt using a vacuum cleaner.
  - 2 Wash back of the air filter with water.
  - 3 If badly soiled, wash it with soap or a mild household detergent.
  - 4 Let it dry and reinstall it.  
Be sure the "FRONT" mark is facing you.  
✗ Damaged air filter.  
Consult the nearest authorized dealer.  
Part No.: CWD001098.
- Do not use benzene, thinner, scouring powder or clothes soaked in caustic chemical to clean the unit.

### ■ Cleaning the Front Panel

(Must be removed before washing)

- 1 Raise the front panel higher than the horizontal and pull to remove it.
- 2 Gently wash with water and a sponge.
  - Do not press the front panel too hard when washing.
  - When use kitchen cleaning fluid (neutral detergent), rinse thoroughly.
  - Do not dry the front panel under direct sunlight.
- 3 To affix the front panel, raise the front panel horizontally, match the protruding portion on the indoor unit to the fulcrum and push into place.

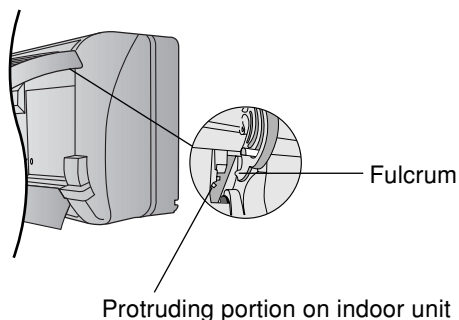

### ■ Air Purifying Filters

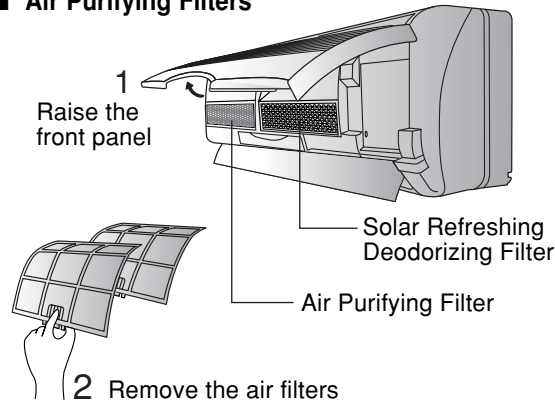

#### ● Solar Refreshing Deodorizing Filter

- Used to remove unpleasant odor and deodorize the air in the room.
- Reusable.
- Vacuum, place under direct sunlight for 6 hours and fit it back in place.  
(Recommended: every 6 months)
- Recommended to change this filter every 3 years.

#### ● Air Purifying Filter

- This new filter helps trap small airborne particles such as dust, pollen and tobacco smoke.
- Recommended : change this filter every 3 months.
- Do not reuse damaged filters.  
Consult the nearest authorized dealer to purchase a new filter.  
Air Purifying Filter No.: CZ-SF51P  
Solar Refreshing Deodorizing Filter No.: CZ-SFD70P
- If you operate the air conditioner with dirty filters:-
  - Air is not purified
  - Cooling or heating capacity decreases
  - Foul odor is emitted

### ■ Pre-season Inspection

#### ● Is the discharged air cold/warm?

Operation is normal if 15 minutes after the start of operation, the difference between the air intake and outlet vents temperature is:-

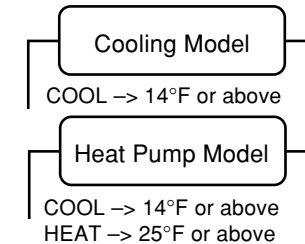

#### ● Are the air intake or outlet vents of the indoor or outdoor units obstructed?

#### ● Are the remote control batteries weak?

If the remote control display appears weak, replace the batteries.

### ■ When the Air Conditioner is Not Used for an Extended Period of Time

- 1 To dry the internal parts of the indoor unit, operate the unit for 2 - 3 hours using:-

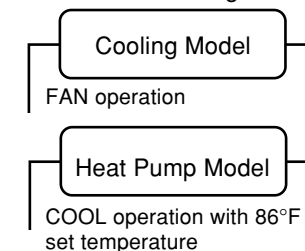

- 2 Stop the operation by remote control and switch off the circuit breaker.

Note : If the unit is not switched off by the remote control, it will start operating when the circuit breaker is switched to ON. (The unit is equipped with Auto Restart Control.)

- 3 Remove the remote control batteries.

### ■ Recommended Inspection

- After used over several seasons, the unit will become dirty and thus decreases the unit's performance. Depending on the operation conditions, a dirty unit may produce odor and dust may pollute dehumidification system. Therefore, a seasonal inspection is recommended in addition to regular cleaning. (Consult an authorized dealer.)

## HELPFUL INFORMATION

### ■ Auto Operation Button



- Raise the front panel and press.

### ● Automatic Operation

- If the remote control fails to function or has been misplaced, press the Auto Operation button to start the Automatic operation.
- The Automatic operation will be activated immediately once the Auto operation button is pressed. However, temperature cannot be adjusted when in this mode.
- The power indicator on the indoor unit will blink until the operation mode is selected automatically.
- To cancel this operation, press once more.

### ● Remote Control Signal Receiving Sound

- To switch off the beep (Signal Receiving Sound), press the Auto Operation button for 10 seconds continuously or longer.
  - A “beep”, “beep” sound will be heard at the tenth seconds.
- Note : A “beep” sound will be heard at the fifth seconds;
  - However please press continuously until you heard “beep”, “beep” sound.
- Repeat the above steps if you want to switch on the Signal Receiving Sound.

### ● (This is for Servicing purposes only.)

- Note: If you press this button continuously for 5 to 10 seconds, Test Run operation will be performed. A “beep” sound will be heard after five seconds indicating the Test Run starts to operate.

### ■ Auto Restart Control

- If power is resumed after a power failure, the operation will restart automatically after 3 - 4 minutes.
- Operation will be restarted automatically under the previous operation mode and airflow direction when power is resumed as the operation is not stopped by the remote control.

### ■ Timer Setting

- When power failure occurs, the timer setting will be cancelled. Once power is resumed, reset the timer.

### ■ Thunder and Lightning

- This air conditioner is equipped with a built-in surge protective device. However, in order to further protect your air conditioner from being damaged by abnormally strong lightning activity, you may switch off the circuit breaker.

## ENERGY SAVING AND OPERATION HINTS

### ■ Setting the Temperature

- Approximately 10% of electricity can be saved.
- Set the temperature higher or lower than the desired temperature.

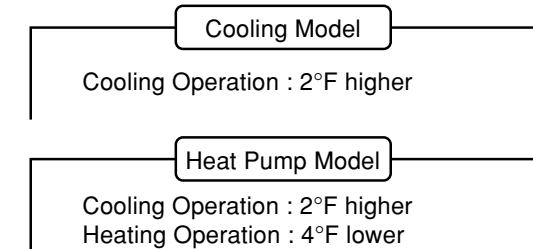

### ■ Air Filters

- Clean the air filters every 2 weeks.
- Dirty filters may reduce cooling or heating efficiency.

### ■ Keep All Doors and Windows Closed

- Otherwise, cooling or heating performance will be reduced and electricity cost is wasted.

### ■ Outdoor Unit

- Do not block the air outlet vents. Otherwise, it will lower the cooling or heating performance.

### ■ Timer

- To prevent wastage of electricity, use Timer when going out.

### ■ Avoid Direct Sunlight

- Keep curtains or drapes closed to avoid direct sunlight during cooling operation.

## TROUBLESHOOTING

### ■ Normal Operation

Is it okay?	Solution
<ul style="list-style-type: none"> <li>• Air conditioner has been restarted, but does not operate for 3 minutes.</li> </ul>	<ul style="list-style-type: none"> <li>• This is to protect the air conditioner. Wait until the air conditioner begins to operate.</li> </ul>
<ul style="list-style-type: none"> <li>• A sound like water flowing can be heard.</li> </ul>	<ul style="list-style-type: none"> <li>• This is the sound of refrigerant flowing inside the air conditioner.</li> </ul>
<ul style="list-style-type: none"> <li>• It seems that fog is coming out from the air conditioner.</li> </ul>	<ul style="list-style-type: none"> <li>• Condensation occurs when the airflow from the air conditioner cools the room.</li> </ul>
<ul style="list-style-type: none"> <li>• The room has a peculiar odor.</li> </ul>	<ul style="list-style-type: none"> <li>• This may be a damp smell emitted by the wall, carpet, furniture or clothing in the room.</li> </ul>
<ul style="list-style-type: none"> <li>• During Automatic Vertical Airflow setting, indoor fan stops occasionally.</li> </ul>	<ul style="list-style-type: none"> <li>• This is to remove smell emitted by the surroundings.</li> </ul>
<ul style="list-style-type: none"> <li>• The outdoor unit emits water or steam.</li> </ul>	<ul style="list-style-type: none"> <li>• In COOL/DRY operation, moisture in the air condenses into water on the cool surface of outdoor unit piping that causes dripping.</li> </ul>
<ul style="list-style-type: none"> <li>• (For Heat Pump Model only) Operation stops for about 12 minutes during heating (The power indicator blinks.)</li> </ul>	<ul style="list-style-type: none"> <li>• This is to melt the frost which has accumulated on the outdoor unit (defrosting operating). This will take no longer than about 12 minutes. Water drips from the outdoor unit. Wait until this operation ends. (The power indicator will light up.) (Frost accumulates on the outdoor unit when the outdoor temperature is low and humidity is high.)</li> </ul>
<ul style="list-style-type: none"> <li>• (For Heat Pump Model only) During heating operation, indoor fan may run at on and off conditions.</li> </ul>	<ul style="list-style-type: none"> <li>• This is to prevent undesired cooling effect during heating operation.</li> </ul>

### ■ Abnormal Operation

Check the following points before calling for repairs or service. If the malfunction persists, please contact your nearest servicenter. For assistance, please call: (866)-292-7292, for Hawaii residents call (808)-488-7779.

Symptoms?	Please check
<ul style="list-style-type: none"> <li>• <b>The air conditioner does not operate.</b></li> </ul>	<ul style="list-style-type: none"> <li>• Has the circuit breaker been tripped?</li> <li>• Is the timer being used correctly?</li> </ul>
<ul style="list-style-type: none"> <li>• <b>Air conditioner produces loud noise during operation.</b></li> </ul>	<ul style="list-style-type: none"> <li>• Is the installation work slanted?</li> <li>• Is the front grille closed properly?</li> </ul>
<ul style="list-style-type: none"> <li>• <b>The air conditioner does not cool or warm effectively.</b></li> </ul>	<ul style="list-style-type: none"> <li>• Has the temperature been set incorrectly?</li> <li>• Are the filters dirty?</li> <li>• Are the intake or outlet vents of the outdoor unit obstructed?</li> <li>• Are all windows and doors closed?</li> </ul>
<ul style="list-style-type: none"> <li>• <b>Remote control / display doesn't work.</b></li> </ul>	<ul style="list-style-type: none"> <li>• Batteries not inserted?</li> <li>• Batteries correctly inserted (+) and (-)?</li> </ul>

### ■ Call the Dealer Immediately

If the following conditions occur, turn off the circuit breaker, and then call your authorized Panasonic dealers or servicenter.

- **Abnormal noise is heard during operation.**
- **Water or foreign material gets into the remote control by mistake.**
- **Water leak from the indoor unit.**
- **Switches or buttons do not operate properly.**
- **The circuit breaker switches off frequently.**
- **Power supply cord becomes unusually warm.**

Service information can be obtained by calling (866)-292-7292, for Hawaii residents call (808)-488-7779.

To expedite the repair of your air conditioner:

- Please have your proof of purchase.
- List all symptoms the unit is exhibiting.



## PRODUCT SPECIFICATIONS

Models				CS-C9CKPG CU-C9CKP6G	CS-C12CKPG CU-C12CKP6G	CS-A9CKPG CU-A9CKP6G	CS-A12CKPG CU-A12CKP6G
ELECTRICAL RATING	Phase			1	1	1	1
	Frequency	(Hz)	60	60	60	60	
	Voltage	(V)	115	115	115	115	
COOLING	Capacity	(Btu/h)	8,800	12,300	8,200	12,000	
	Current	(Amp)	7.2	10.3	7.4	10.6	
	Input Power	(Watts)	790	1,160	810	1,200	
	EER	(Btu/Watt.h)	11.10	10.60	10.12	10.00	
	SEER		12.4	11.20	10.8	10.6	
	Room Air Circulation	(cf/min)	310	340	310	340	
HEATING	Capacity	(Btu/h)	–	–	9,200	13,500	
	Current	(Amp)	–	–	6.7	10.5	
	Input Power	(Watts)	–	–	730	1,190	
	COP	(Btu/Watt.h)	–	–	12.60	11.34	
	HSPF		–	–	8.0	7.4	
	Room Air Circulation	(cf/min)	–	–	350	360	
MOISTURE REMOVAL		(pints/h)	1.7	3.0	1.5	2.7	
DIMENSIONS	Indoor	Height	cm (inches)	27.5 (10 – 13/16)	←	←	←
		Width	cm (inches)	79.9 (31 – 15/32)	←	←	←
		Depth	cm (inches)	21.0 (8 – 9/32)	←	←	←
	Outdoor	Height	cm (inches)	54.0 (21 – 1/4)	←	←	←
		Width	cm (inches)	78.0 (30 – 23/32)	←	←	←
		Depth	cm (inches)	28.9 (11 – 3/8)	←	←	←
NET WEIGHT	Indoor	kg (lb)	9 (20)	←	←	←	
	Outdoor	kg (lb)	29 (64)	33 (73)	31 (68)	35 (77)	
GROSS WEIGHT	Indoor	kg (lb)	11 (24)	←	←	←	
	Outdoor	kg (lb)	33 (73)	37 (82)	35 (77)	39 (86)	

- Specifications are subject to change without notice for further improvement.

## ■ REFERENCE

Model Number:

-----

Dealer's Address:

-----

Dealer's Tel :

-----

Serial Number :  
(Located on the side of unit)

-----

Date of Purchase :

-----

Dealer's Name:

-----

Please affix your proof of purchase here for future reference.

PANASONIC CONSUMER ELECTRONICS COMPANY,  
DIVISION OF MATSUSHITA ELECTRIC  
CORPORATION OF AMERICA  
One Panasonic Way  
Secaucus, New Jersey 07094

PANASONIC SALES COMPANY,  
DIVISION OF MATSUSHITA ELECTRIC OF PUERTO RICO, INC.,  
Ave. 65 de Infanteria, Km. 9.5  
San Gabriel Industrial Park  
Carolina, Puerto Rico 00985

## Panasonic Split Air Conditioner Products Parts Limited Warranty

### Limited Warranty Coverage

If your product does not work properly because of a defect in materials or workmanship in a Panasonic provided part, Panasonic Consumer Electronics Company or Panasonic Sales Company (collectively referred to as "the warrantor") will, for the length of the period indicated on the chart below, which starts with the date of purchase ("warranty period"), at its option, repair or provide a replacement for that part(s) with new or refurbished parts.

Product or Part Name	Parts
All components of Split Air Conditioner except Compressor and Remote Control Transmitter	One (1) Year
Compressor	Five (5) Year
Remote Control Transmitter (in exchange for defective item)	Ninety (90) Days

During the warranty period, there will be no charge for parts. **This warranty does not include labor** for replacing defective parts or other costs incurred for servicing such as contractor visit or contractor minimum charges, installing, removing, shipping or handling. Such cost may or may not be covered by a separate warranty provided by the contractor who installed the product. If a part or parts are defective, the contractor will advise Panasonic, and Panasonic will forward the replacement part(s) to the contractor. If non-rechargeable batteries are included, they are not warranted. This limited warranty only applies to products purchased and serviced in the United States or Puerto Rico and is extended only to the original purchaser of a new product which was not sold "as is". A purchase receipt or other proof of the original purchase/installation date is required for warranty service.

### Exercising Your Warranty

To exercise your warranty in the United States contact the contractor who installed the product or, in all states other than Hawaii call (866)-292-7292; for Hawaii residents call (808)-488-7779. For assistance in Puerto Rico call Panasonic Sales Company (787)-750-4300 or fax (787)-768-2910.

### Limited Warranty Limits And Exclusions

This warranty ONLY COVERS failures due to defects in materials or workmanship in components provided by Panasonic, and DOES NOT COVER normal wear and tear or cosmetic damage. The warranty ALSO DOES NOT COVER damages which occurred in shipment, or failures which are caused by products not supplied by the warrantor, or failures which result from accidents, misuse, abuse, neglect, mishandling, misapplication, alteration, faulty installation, set-up adjustments, operating the product in a corrosive atmosphere containing chlorine, fluorine, or any other chemicals, misadjustment of consumer controls, improper maintenance, power line surge, lightning damage, modification, or service by anyone other than an authorized contractor, or damage that is attributable to acts of God.

**THERE ARE NO EXPRESS WARRANTIES EXCEPT AS LISTED UNDER "LIMITED WARRANTY COVERAGE". THE WARRANTOR IS NOT LIABLE FOR INCIDENTAL OR CONSEQUENTIAL DAMAGES RESULTING FROM THE USE OF THIS PRODUCT, OR ARISING OUT OF ANY BREACH OF THIS WARRANTY.** (As examples, this excludes damages for lost time, parts used in connection with normal maintenance such as air filters and owner-required maintenance. The items listed are not exclusive, but are for illustration only.) **ALL EXPRESS AND IMPLIED WARRANTIES, INCLUDING THE WARRANTY OF MERCHANTABILITY, ARE LIMITED TO THE PERIOD OF THE LIMITED WARRANTY.**

Some states do not allow the exclusion or limitation of incidental or consequential damages, or limitations on how long an implied warranty lasts, so the exclusions may not apply to you.

This warranty gives you specific legal rights and you may also have other rights which vary from state to state. If a problem with this product develops during or after the warranty period, you may contact your authorized contractor. If the problem is not handled to your satisfaction, then write to the warrantor's Consumer Affairs Department at the addresses listed for the warrantor.

**PARTS WHICH ARE NOT COVERED BY THIS LIMITED WARRANTY, INCLUDING WITHOUT LIMITATION THE COST OF AN IN-HOME SERVICE CALL, ARE YOUR RESPONSIBILITY.**