

Panasonic®

Room Air Conditioner

OPERATING INSTRUCTIONS

Before using your air-conditioner, please read this operating instructions carefully and keep it for future reference.



COOLING MODEL :-

Indoor
CS-C18BKP
CS-C24BKP

Outdoor
CU-C18BKP6
CU-C24BKP6

ENGLISH P. 1 – P. 11
ESPAÑOL P.12 – P. 21

For assistance, please call; 1-800-211-PANA(7262) or send e-mail to:
consumerproducts@panasonic.com or refer to
www.panasonic.com

Thank you for purchasing our Panasonic Room Air Conditioner.

CONTENTS

- ▶ **Features** 1
- ▶ **Safety Precautions** 2
 - Installation Precautions
 - Operation Precautions
- ▶ **Name of Each Part** 3~4
 - Indoor Unit
 - Outdoor Unit
 - Accessories
 - Remote Control
- ▶ **Preparation Before Operation** 5
 - Indoor Unit
 - Remote Control
- ▶ **How to Operate** 5~6
- ▶ **Setting the Timer** 7
- ▶ **Convenience Operation** 7
 - Sleep Mode Operation
 - Economy Mode Operation
 - Powerful Mode Operation
- ▶ **Care and Maintenance** 8
 - Cleaning the Indoor Unit and Remote Control
 - Cleaning the Air Filter
 - Cleaning the Front Panel
 - Air Purifying Filters
 - Pre-season Inspection
 - When the Air Conditioner is Not Used for an Extended Period of Time
 - Recommended Inspection
- ▶ **Helpful Information** 9
- ▶ **Energy Saving and Operation Hints** 9
- ▶ **Troubleshooting** 10
 - Normal Operation
 - Abnormal Operation
 - Call the Dealer Immediately

Note:

Before using your air conditioner, please read this operating instructions carefully and keep it for future reference.

FEATURES

- **Self-illuminating Button**
For your convenience to operate in the dark. (Refer page 4)
- **Automatic Operation**
Sense indoor temperature to select the optimum mode. (Refer page 5)
- **Sleep Mode**
Prevent the room from getting too hot or too cold while you are sleeping. (Refer page 7)
- **Economy Mode**
To reduce electrical power consumption. (Refer page 7)
- **Powerful Mode**
Reaches the desired room temperature quickly. (Refer page 7)
- **Removable Front Panel**
For quick and easy cleaning. (washable) (Refer page 8)
- **Catechin Air Purifying Filter**
Filter that can trap dust, tobacco smoke and tiny particles in the room. It can also prevent growth of bacteria and viruses trapped in this filter. (Refer page 8)
- **Solar Refreshing Deodorizing Filter**
Used to remove unpleasant odour and deodorize the air in the room. (Refer page 8)
- **Auto Restart Control**
Restart the unit automatically after power failure. (Refer page 9)
- **Blue Coated Condenser At Outdoor Unit**
This is the most advanced anti-rust coating.

Warning

- 1) Operate your air conditioner from a stable 208/230 volts AC supply.
- 2) Plug into a separate 15 amps (CS-C18BKP/CU-C18BKP6) or 20 amps (CS-C24BKP/CU-C24BKP6) grounded outlet only.
- 3) Use of extension cords.
Avoid using extension cords. If there are no alternatives, ensure that the cord is a UL listed 3-wire grounding type, rated 250 volt with a minimum current-carrying rating of 15 amps (CS-C18BKP/CU-C18BKP6) or 20 amps (CS-C24BKP/CU-C24BKP6), number 14 (CS-C18BKP/CU-C18BKP6), number 12 (CS-C24BKP/CU-C24BKP6) or a heavier wire.
- 4) Use a 15 amps (CS-C18BKP/CU-C18BKP6) or 20 amps (CS-C24BKP/CU-C24BKP6) time delay fuse or a circuit breaker.
- 5) Do not switch off by unplugging the power plug while it is operating. Turn off the air conditioner by using remote control, before unplugging.
- 6) Remove power plug or disconnect from the main before servicing this appliance.
- 7) Do not repair by yourself.
In case of malfunction of this appliance, do not repair by yourself. Contact the sales dealer or service dealer for a repair.
- 8) Turn off the power (Isolation from main power supply). Pull off the power plug from the receptacle, or switch off the breaker, or switch off the power disconnecting mean to isolate the equipment from the main power supply in case of an emergency.

Caution

DISCONNECT THE MAIN PLUG FROM THE SUPPLY SOCKET WHEN NOT IN USE, WHERE SUPPLY CONNECTION IS VIA MAIN PLUG.

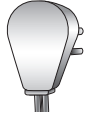
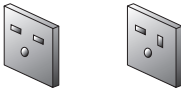
POWER SUPPLY	
Time Delay Fuse: 15 Amps (CS-C18BKP/ CU-C18BKP6) 20 Amps (CS-C24BKP/ CU-C24BKP6)	Line Cord Plug: 
Rated Volts: 208/230 V	Socket Type:  (CS-C18BKP/ CU-C18BKP6) (CS-C24BKP/ CU-C24BKP6)

SAFETY PRECAUTIONS

Before operating, please read the following "Safety Precautions" carefully.

- To prevent personal injury, injury to others and property damage, the following instructions must be followed.
- Incorrect operation due to failure to follow instructions will cause harm or damage, the seriousness of which is classified as follow:



Warning

This sign warns of death or serious injury.



Caution

This sign warns of damage to property.

- The instructions to be followed are classified by the following symbols:



This symbol (with a white background) denotes an action that is PROHIBITED.



These symbols (with a black background) denote actions that are COMPULSORY.

■ Installation Precautions



Warning

- **Do not install, remove and reinstall the unit by yourself.**
Improper installation will cause leakage, electric shock or fire. Please engage an authorized dealer or specialist for the installation work.



Caution



- **This room air conditioner must be earthed.**
Improper grounding could cause electric shock.

- **Ensure that the drainage piping is connected properly.**
Otherwise, water will leak out.



- **Do not install the unit in a potentially explosive atmosphere.**
Gas leak near the unit could cause fire.

■ Operation Precautions



Warning

This sign warns of death or serious injury.



- Do not share outlet.
- Do not insert plug to operate the unit. Do not pull out plug to stop the unit.
- Do not operate with wet hands.
- Do not damage or modify the power cord.
- Do not insert finger or other objects into the indoor or outdoor units.
- Do not expose directly to cold air for a long period.



- Plug in properly.
- Use specified power cord.



- If abnormal condition (burnt smell, etc.) occurs, switch off and unplug the power supply.



Caution

This sign warns of injury.



- Do not pull the cord to disconnect the plug.
- Do not wash the unit with water.
- Do not use for other purposes such as preservation.
- Do not use any combustible equipment at airflow direction.
- Do not sit or place anything on the outdoor unit.



- Switch off the power supply before cleaning.
- Ventilate the room regularly.
- Pay attention as to whether the installation rack is damaged after long period of usage.



- Switch off the power supply if the unit is not used for a long period.

NAME OF EACH PART

■ Indoor Unit

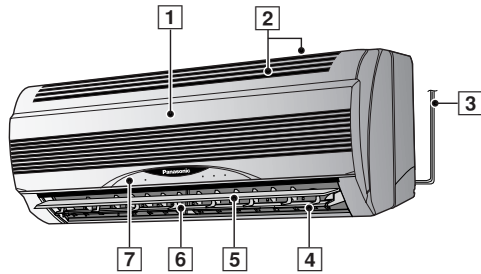

- 1 Front Panel
- 2 Air Intake Vent
- 3 Power Supply Cord
- 4 Air Outlet Vent
- 5 Vertical Airflow Direction Louver
- 6 Horizontal Airflow Direction Louver
- 7 Indicator Panel

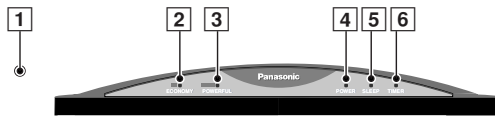

- 1 Auto Operation Button
(when the front panel is opened)
- 2 Economy Mode Indicator – GREEN
- 3 Powerful Mode Indicator – ORANGE
- 4 Power Indicator – GREEN
- 5 Sleep Mode Indicator – ORANGE
- 6 Timer Mode Indicator – ORANGE

● Indoor Unit (when the front panel is opened)

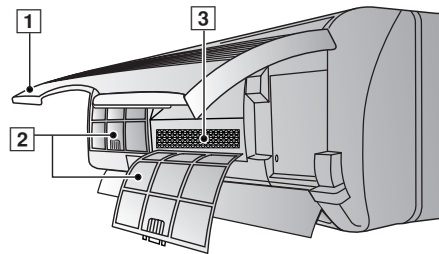

- 1 Front Panel
- 2 Air Filters
- 3 Air Purifying Filter

■ Outdoor Unit

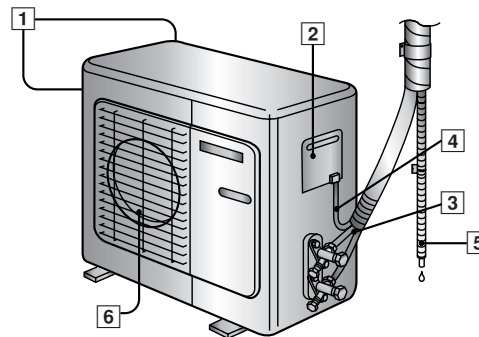

- 1 Air Intake Vents
- 2 Ground Terminal
(Inside cover)
- 3 Piping
- 4 Connecting Cable
- 5 Drain Hose
- 6 Air Outlet Vents

■ Accessories

● Remote Control



● Remote Control Holder

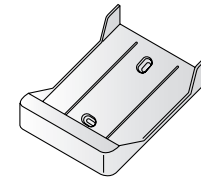

● Two RO3 (AAA) dry-cell batteries or equivalent

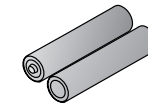

● Air Purifying Filter

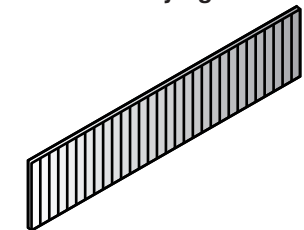

(Catechin Air Purifying Filter)

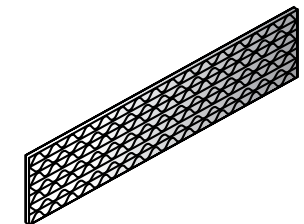

(Solar Refreshing Deodorizing Filter)

NAME OF EACH PART

■ Remote Control

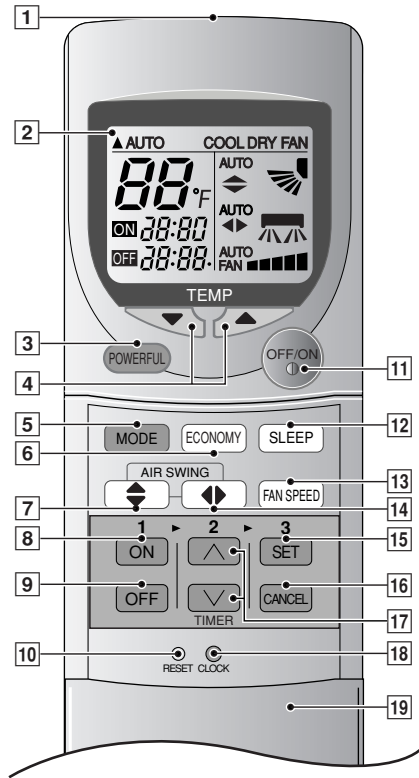

● Remote Control Signal.

- Make sure it is not obstructed.
- Maximum distance : 10 m (32.8 ft.).
- Signal received sound.
One short beep or one long beep.

● Notes for Remote Control.

- Do not throw or drop.
- Do not get it wet.
- Certain type of fluorescent lamps may affect signal reception. Consult your dealer.

- 1 Signal Transmitter
- 2 Operation Display
- 3 Powerful Mode Operation Button
- 4 Room Temperature Setting Button (self-illuminating button)
- 5 Operation Mode Selection Button
- 6 Economy Mode Operation Button
- 7 Vertical Airflow Direction Button
- 8 ON-Timer Button
- 9 OFF-Timer Button
- 10 Reset Point
(Press with fine-tipped object to clear the memory)
- 11 OFF/ON Button
(self-illuminating button)
- 12 Sleep Mode Operation Button
- 13 Fan Speed Selection Button
- 14 Horizontal Airflow Direction Button
- 15 Timer Set Button
- 16 Timer Cancellation Button
- 17 Time-Setting Button
- 18 Clock Button
- 19 Remote Control Cover

● How to Insert the Batteries

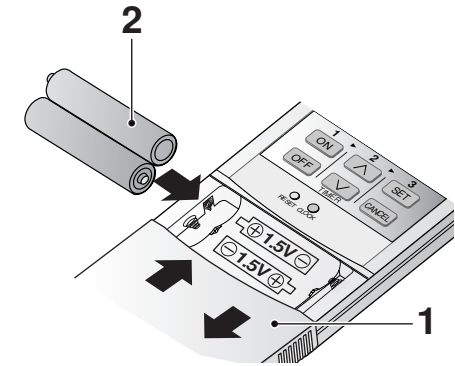

1 Slide down the remote control cover completely

2 Insert the batteries

- Be sure the direction is correct
- 12.00 at display - flashing
- Set the current time (CLOCK) immediately to prevent battery exhaustion.

● About the batteries

- Can be used for approximately one year.

● Observe the following when replacing the batteries

- Replace with new batteries of the same type.
- Do not use rechargeable batteries (Ni-Cd).
- Remove the batteries if the unit is not going to be used for a long period.

PREPARATION BEFORE OPERATION

Indoor Unit

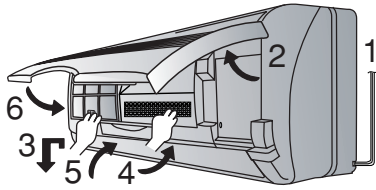

- 1 Connect the power supply cord to an independent power supply
- 2 Open the front panel
- 3 Remove the air filters
- 4 Fit the air purifying filters in place
- 5 Insert the air filters
- 6 Close the front panel

Remote Control

– To set the current time

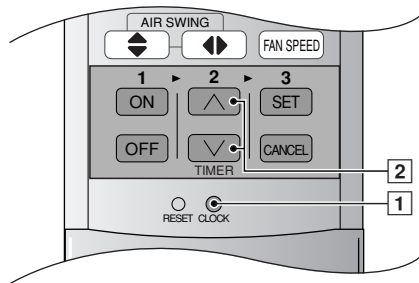

- 1 Press **1**.
- 2 Then press **2** to increase or decrease the time.
- 3 Press **1** again.
Set time at display will light up.

HOW TO OPERATE

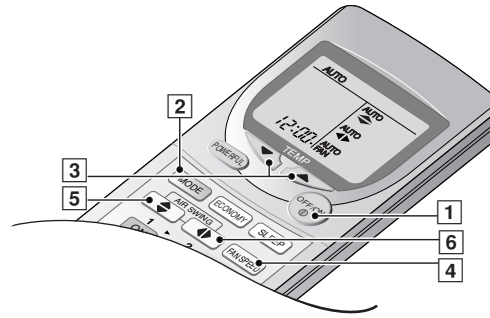

To start the operation

- Press **1**.
- POWER indicator (green) on the indoor unit will light up.
- To stop, press once more.

Setting Mode

- Press **2** to select:-

AUTO – Automatic Operation
 COOL – Cooling Operation
 DRY – Soft Dry Operation
 FAN – Air Circulation Operation

Setting Temperature

- Press **3** to increase or decrease the temperature.
- The temperature can be set between 60°F ~ 86°F.
- Recommended temperature:

COOL	75°F ~ 78°F
DRY	2°F ~ 4°F Lower than the room temperature

- During **AUTO** Operation, press **3** to select:-



- Operation with 4°F higher than the standard temperature.



- Operation with the standard temperature.



- Operation with 4°F lower than the standard temperature.

Standard Temperature

Indoor temperature	Operation	Standard temperature
73°F	Cooling	77°F
	Soft Dry	72°F

- Once the Automatic Operation is selected, the indoor temperature sensor operates automatically to select the desired operation mode with Cooling or Soft Dry.
- After the operation mode has been selected, the mode does not change.

■ Setting the Fan Speed

- Press **[4]** to select:-

FAN ■ – Low Fan Speed
 FAN ■ ■ ■ – Medium Fan Speed
 FAN ■ ■ ■ ■ ■ – High Fan Speed
 AUTO
 FAN – Automatic Fan Speed

The speed of the indoor fan is adjusted automatically according to the operation. The indoor fan stops occasionally during cooling operation.

■ Setting the Vertical Airflow Direction

- Press **[5]** to select:-

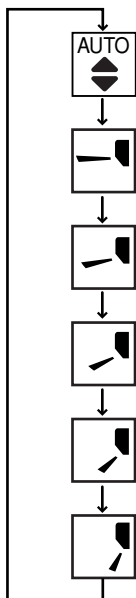

-  • Swing up/down automatically.

■ Setting the Horizontal Airflow Direction

- Press **[6]** to select:-

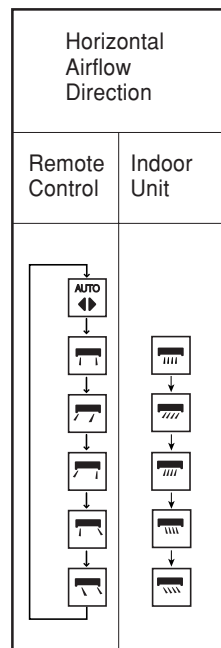

-  • Swing left/right automatically.

● Notes

- If the unit is not going to be used for an extended period of time, turn off the main power supply. If it is left at the ON position, approximately 2.5 W of electricity will be used even if the indoor unit has been turned off with the remote control.
- If operation is stopped, then restart immediately, the unit will resume operation only after 3 minutes.

● Operation Details

COOL – Cooling Operation

- To set the room temperature at your preference cooling comfort.

AUTO – Automatic Operation

- Sense indoor temperature to select the optimum mode.
- Temperature is not displayed on the remote control during AUTO operation.

DRY – Soft Dry Operation

- A very gentle Cooling Operation, prior to dehumidification. It does not lower the room temperature.
- During Soft Dry operation, the indoor fan operates at Low fan speed.

FAN – Air Circulation Operation

- When the room temperature reaches the set temperature, operation commences at Low airflow volume. It stops when the room temperature drops to 4°F below the set temperature. (It is useful when using a heater).

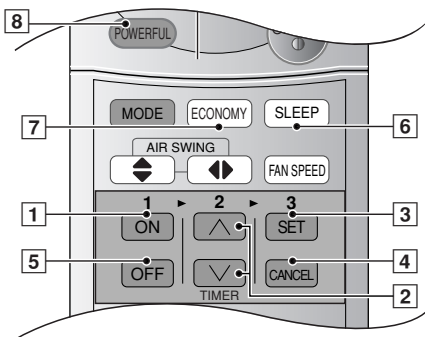

SETTING THE TIMER

Ensure that the current time is correct before setting the timer. The timer cannot be set if the time display is flashing.

■ ON-TIMER Operation

To start the air conditioner operation automatically.

- Press [1] to set the operation.
- Press [2] to increase or decrease the time.
- Then press [3].
- To cancel this operation, press [4].

■ OFF-TIMER Operation

To stop the air conditioner operation automatically.

- Press [5] to set the operation.
- Press [2] to increase or decrease the time.
- Then press [3].
- To cancel this operation, press [4].

● Timer Mode Operation Details

- When the ON-Timer is set, operation will start before the actual set time. This is to enable the room temperature reaches the set temperature at the set time.

COOL, DRY, AUTO	15 minutes in advance
--------------------	--------------------------

- Once the ON-Timer is set, operation will start at the set time everyday.
- The current time is not displayed when the timers are set.
- When both timers are used together, the TIMER mode indicator on the indoor unit remains lit even when the operation is stopped by the OFF-TIMER.

CONVENIENCE OPERATION

■ Sleep Mode Operation

To obtain a comfortable room temperature while sleeping:-

- Press [6].
- Sleep mode indicator on the indoor unit will light up.
- To cancel this operation, press once more.

● Sleep Mode Operation Details

- When the room temperature reaches the set temperature, the airflow volume will change to low automatically.
- Sleep Mode Operation time is 8 hours.
- When used together with the timer, the timer has a priority.

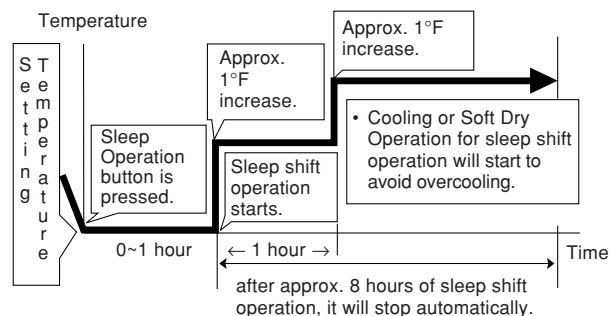

■ Economy Mode Operation

To save electrical power consumption.

Please use this mode when the room has reached your desired temperature.

- Press [7].
- ✗ Economy mode indicator (green) on the indoor unit will light up.
- Press once more to cancel this operation.

■ Powerful Mode Operation

To obtain the set temperature quickly.

- Press [8].
- ✗ Powerful mode indicator (orange) on the indoor unit will light up.
- ✗ Powerful mode will operate for 15 minutes only.
- To cancel this operation, press once more.

● Economy / Powerful Mode Operation Details

- Economy and Powerful operation cannot be selected simultaneously.
- The changes of the temperature and airflow volume are automatic.
- The remote control display remains unchanged.
- If sleep button or operation mode button is pressed, economy or powerful operation will be cancelled.
- During **FAN** – Air circulation operation, the powerful and economy operation are not available.

	Temperature	Airflow volume
Economy Mode Operation	1°F higher than set temp.	Super Low
Powerful Mode Operation	5°F lower than set temp.	Super High

CARE AND MAINTENANCE

■ Cleaning the Indoor Unit and Remote Control

- Wipe gently with a soft, dry cloth.
- Do not use water hotter than 104°F or polishing fluid to clean the unit.

■ Cleaning the Air Filter

(Recommendation:- If the unit is operated in a dusty environment, clean the filters every two weeks, continuous use of this dirty filters will reduce cooling efficiency)

- 1 Remove dirt using a vacuum cleaner.
 - 2 Wash back of the air filter with water.
 - 3 If badly soiled, wash it with soap or a mild household detergent.
 - 4 Let it dry and reinstall it.
Be sure the "FRONT" mark is facing you.
※ Damaged air filter.
Consult the nearest authorized dealer.
Part No.: CWD001049.
- Do not use benzene, thinner, scouring powder or clothes soaked in caustic chemical to clean the unit.

■ Cleaning the Front Panel

(Must be removed before washing)

- 1 Raise the front panel higher than the horizontal and pull to remove it.
- 2 Gently wash with water and a sponge.
 - Do not press the front panel too hard when washing.
 - When use kitchen cleaning fluid (neutral detergent), rinse thoroughly.
 - Do not dry the front panel under direct sunlight.
- 3 To fix the front panel, raise the front panel horizontally, match the protruding portion on the indoor unit to the fulcrum and push into place.

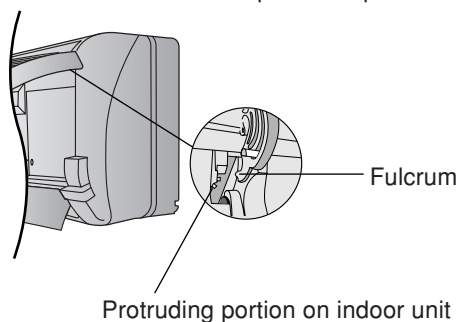

■ Air Purifying Filters

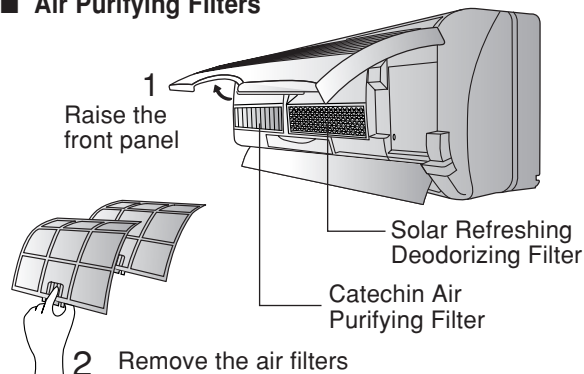

● Solar Refreshing Deodorizing Filter

- Used to remove unpleasant odour and deodorize the air in the room.
- Reusable.
- Vacuum, place under direct sunlight for 6 hours and fit it back in place.
(Recommended : every 6 months)

● Catechin Air Purifying Filter

- The filter is coated with catechin to prevent growth of bacteria and viruses.
 - Reusable.
 - Vacuum and fit it back in place
(Recommended : every 6 months)
- Recommended to change these filters every 3 years. Do not reuse damaged filters.
Consult the nearest authorized dealer to purchase a new filter.
Catechin Air Purifying Filter No.: CZ-SF70P
Solar Refreshing Deodorizing Filter No.: CZ-SFD70P
 - If you operate the air conditioner with dirty filters:-
 - Air is not purified
 - Cooling capacity decreases
 - Foul odour is emitted

■ Pre-season Inspection

● Is the discharged air cold?

Operation is normal if 15 minutes after the start of operation, the difference between the air intake and outlet vents temperature is:-

COOL – 14°F or above

- Are the air intake or outlet vents of the indoor or outdoor units obstructed?
- Are the remote control batteries weak?
If the remote control display appears weak, replace the batteries.

■ When the Air Conditioner is Not Used for an Extended Period of Time

- 1 To dry the internal parts of the indoor unit, operate the unit for 2 - 3 hours using:-

FAN operation

- 2 Turn off the power supply and unplug.
Note: If the unit is not switched off by the remote control, it will start operating when you plug in (because the unit is equipped with Auto Restart Control).
- 3 Remove the remote control batteries.

■ Recommended Inspection

- After used over several seasons, the unit will become dirty and thus decreases the unit's performance. Depending on the operation conditions, a dirty unit may produce odour and dust may pollute dehumidification system. Therefore, a seasonal inspection is recommended in addition to regular cleaning. (Consult an authorized dealer).

HELPFUL INFORMATION

■ Auto Operation Button

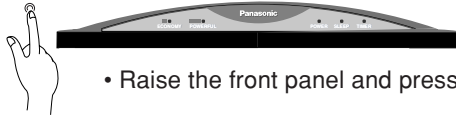

- Raise the front panel and press.

● Automatic Operation

- If the remote control fails to function or has been misplaced, press the Auto Operation button to start the Automatic operation.
- The Automatic operation will be activated immediately once the Auto operation button is pressed. However, temperature cannot be adjusted in this operation.
- The power indicator on the indoor unit will blink until the operation mode is selected automatically.
- To cancel this operation, press once more.

● Remote Control Signal Receiving Sound

- To switch off the beep (Signal Receiving Sound), press the Auto Operation button for 10 seconds continuously or longer.
“Beep”, “beep” sound will be heard at the tenth seconds.
Note: “Beep” sound will be heard at the fifth seconds;
However please press continuously until you heard “beep”, “beep” sound.
- Repeat the above steps if you want to switch on the Signal Receiving Sound.

● (This is for Servicing purposes only.)

- Note: If you press this button continuously for 5 to 10 seconds, Test Run operation will be performed. A “beep” sound will be heard at the fifth seconds indicating the Test Run starts to operate.

■ Auto Restart Control

- If power is resumed after a power failure, the operation will restart automatically after 3 - 5 1/2 minutes.
- Operation will be restarted automatically under the previous operation mode and airflow direction when power is resumed as the operation is not stopped by the remote control.

■ Timer Setting

- When power failure occurs, the timer setting will be cancelled. Once power is resumed, reset the timer.

■ Thunder and Lightning

- This air conditioner is equipped with a built-in surge protective device. However, in order to further protect your air conditioner from being damaged by abnormally strong lightning activity, you may switch off the main power supply and unplug from power socket.

ENERGY SAVING AND OPERATION HINTS

■ Setting the Temperature

- Approximately 10% of electricity can be saved.
- Set the temperature 2°F higher than the desired temperature.

■ Air Filters and Air Purifying Filters

- Clean the air filters every 2 weeks and the Air Purifying Filters every 6 months.
- Dirty filters may reduce cooling efficiency.

■ Keep All Doors and Windows Closed

- Otherwise, cooling performance will be reduced and electricity cost is wasted.

■ Outdoor Unit

- Do not block the air outlet vents. Otherwise, it will lower the cooling performance.

■ Timer and Sleep Mode

- To prevent wastage of electricity, use sleep mode when sleeping or Timer when going out.

■ Avoid Direct Sunlight

- Keep curtains or drapes closed to avoid direct sunlight during cooling operation.

TROUBLESHOOTING

■ Normal Operation

Is it okay?

- Air conditioner has been restarted, but does not operate for 3 minutes.
- A sound like water flowing can be heard.
- It seems that fog is coming out from the air conditioner.
- The room has a peculiar odour.
- During Automatic Vertical Airflow setting, indoor fan stops occasionally.
- The outdoor unit emits water or steam.

This is the answer

- ➔ • This is to protect the air conditioner. Wait until the air conditioner begins to operate.
- ➔ • This is the sound of refrigerant flowing inside the air conditioner.
- ➔ • Condensation occurs when the airflow from the air conditioner cools the room.
- ➔ • This may be a damp smell emitted by the wall, carpet, furniture or clothing in the room.
- ➔ • This is to remove smell emitted by the surroundings.
- ➔ • In COOL/DRY operation, moisture in the air condenses into water on the cool surface of outdoor unit piping that causes dripping.

■ Abnormal Operation

Check the following points before calling for repairs or service.
 If the malfunction persists, please contact your nearest servicenter.
 For assistance, please call: 1-800-211-PANA (7262) or send e-mail to: consumer_products@panasonic.com

Is it okay?

- **The air conditioner does not operate.**
- **Air conditioner produces loud noise during operation.**
- **The air conditioner does not cool effectively.**

Please check

- ➔ • Has the circuit breaker been tripped?
- ➔ • Has the power plug been removed from the wall outlet?
- ➔ • Is the timer being used correctly?
- ➔ • Is the installation work slanted?
- ➔ • Is the front grille closed properly?
- ➔ • Has the temperature been set incorrectly?
- ➔ • Are the filters dirty?
- ➔ • Are the intake or outlet vents of the outdoor unit obstructed?
- ➔ • Are all windows and doors closed?

■ Call the Dealer Immediately

If the following conditions occur, turn off and unplug the main power supply, and then call your authorized Panasonic dealers or servicenter.

Service information can be obtained 24 hours/day by calling

1-800-211 PANA (7262).

To expedite the repair of your air conditioner:

- Please have your proof of purchase.
- List all symptoms the unit is exhibiting.
- **Abnormal noise is heard during operation.**
- **Water or foreign material gets into the remote control by mistake.**
- **Water leak from the indoor unit.**
- **Switches or buttons do not operate properly.**
- **The circuit breaker switches off frequently.**
- **Power supply cord and plug become unusually warm.**



**PRODUCT SPECIFICATIONS
ESPECIFICACIONES DEL PRODUCTO**

Model Modelo		CS-C18BKP CS-C24BKP	CU-C18BKP CU-C24BKP6
COOLING CAPACITY CAPACIDAD DE ENERIAMIENTO	Btu/h		
ELECTRICAL RATING CLASIFICACION DE LA ELECTRICIDAD	Phase Fase Frequency Fréqcuencia Voltage Voltaje Current Corriente	(Hz) (Hz) (V) (V) (Amps) (Amps)	
	Input Potencia	(Watts) (W)	
EER EER		(Btu/Watt.h) (Btu/W-h)	
MOISTURE REMOVAL DÉSHUMIDIFICACION	(Pints/h) (pinte/h)		
ROOM AIR CIRCULATION CIRCULACION DE AIRE	(Cf/min) (pie ³ /min)		
DIMENSIONS DIMENSIONES	Indoor	Height Alto Width Ancho Depth Profundidad	cm(inches) cm(pulgadas) cm(inches) cm(pulgadas) cm(inches) cm(pulgadas)
	Outdoor	Height Alto Width Ancho Depth Profundidad	cm(inches) cm(pulgadas) cm(inches) cm(pulgadas) cm(inches) cm(pulgadas)
NET WEIGHT PESO NETO	Indoor	kg(lb) kg(libras)	
	Outdoor	kg(lb) kg(libras)	
GROSS WEIGHT PESO BRUTO	Indoor	kg(lb) kg(libras)	
	Outdoor	kg(lb) kg(libras)	

- Specifications are subject to change without notice for further improvement.
- Las especificaciones estan sujetas a cambios por mejoras sin previo aviso.

**REFERENCE
REFERENCIA**

Model Number : _____ Dealer's Address : _____
 Numero de modelo : _____ Nombre del comerciante : _____
 Serial Number : _____ Dealer's Tel : _____
 (Located on the side of unit) Telefono del comerciante : _____
 Numero de serie : _____ Date of Purchase : _____
 (Localizado en el costado de la unidad) Fecha de adquisicion : _____
 Dealer's Name : _____
 Nombre del distribuidor: _____

Please affix your proof of purchase here for future reference.
 Favor de pegar la prueba de su compra aquí para su futura referencia.

© 2001 Matsushita Electrical Co, Ltd. All Right Reserved.
 © 2001 Matsushita Electrical Co, Ltd. Derechos Reservados.

**Panasonic Consumer Electronics Company,
Division of Matsushita Electric Corporation
of America**

One Panasonic Way
Secaucus, New Jersey 07094

**Panasonic Sales Company,
Division of Matsushita Electric of Puerto Rico, Inc.,**
Ave. 65 de Infanteria, Km. 9.5
San Gabriel Industrial Park
Carolina, Puerto Rico 00985

**Panasonic Room Air Conditioner
Limited Warranty**

Panasonic Consumer Electronics Company or Panasonic Sales Company (collectively referred to as "the Warrantor") will repair this product with new or refurbished parts in case of defects in material or workmanship, free of charge, in the USA or Puerto Rico in accordance to the following (All time periods start from the date of the original purchase).

SEALED REFRIGERATING SYSTEM (compressor and interconnecting tube): **FIVE (5) YEARS - PARTS AND LABOR**

ALL OTHER COMPONENTS: ONE (1) YEAR - PARTS AND LABOR

In-home service in the USA can be obtained during the warranty period by contacting a Panasonic Service Company (PASC) Factory Servicenter listed in the Servicenter Directory. Or call toll free, 1-800-211-PANA(7262), to locate a PASC authorized Servicenter. In-home service in Puerto Rico can be obtained during the warranty period by calling the Panasonic Sales Company telephone number listed in the Servicenter Directory.

Note: If the unit is installed at the other than normal window height and/or has been custom-installed (e.g. through the wall), the customer is responsible for removing the unit from its installation prior to the performance of in-home service.

This warranty is extended only to the original purchaser. A purchase receipt or other proof of date of the original purchase is required for service and parts replacement under this warranty.

This warranty only covers failures due to defects in materials and workmanship and does not cover normal wear or cosmetic damage. The warranty does not cover damages which occur in shipment, or failures which are caused by products not supplied by the warrantor, or failures which result from accident, misuse, abuse, neglect, mishandling, misapplication, faulty installation, maladjustment of customer controls, improper maintenance, alteration, modification, power line surge, lightning damage, improper voltage supply, commercial use such as hotel, office, restaurant, or other business or rental use of the product, or service by anyone other than a PASC Factory Servicenter or a PASC authorized Servicenter, or damage that is attributable to acts of God.

LIMITS AND EXCLUSIONS

There are no express warranties except as listed above.
THE WARRANTOR SHALL NOT BE LIABLE FOR INCIDENTAL OR CONSEQUENTIAL DAMAGES RESULTING FROM THE USE OF THIS PRODUCT, OR ARISING OUT OF ANY BREACH OF THIS WARRANTY. ALL EXPRESS AND IMPLIED WARRANTIES, INCLUDING THE WARRANTIES OF MERCHANTABILITY, ARE LIMITED TO THE APPLICABLE WARRANTY PERIOD SET FORTH ABOVE.

Some states do not allow the exclusion or limitation of incidental or consequential damages, or limitations on how long an implied warranty lasts, so the above exclusions or limitations may not apply to you.
 This warranty gives you specific legal rights and you may also have other rights which vary from state to state. If a problem with this product develops during or after the warranty period, you may contact your dealer or Servicenter. If the problem is not handled to your satisfaction, then write to the Consumer Affairs Department at the company address indicated above.

SERVICE CALLS WHICH DO NOT INVOLVE DEFECTIVE MATERIALS OR WORKMANSHIP AS DETERMINED BY THE WARRANTOR, IN ITS SOLE DISCRETION, ARE NOT COVERED. COSTS OF SUCH SERVICE CALLS ARE THE RESPONSIBILITY OF THE PURCHASER.

[For assistance, please call: 1-800-211-PANA (7262) or send e-mail to consumerproducts@panasonic.com]

F563385

Printed in Malaysia
P0111-1