

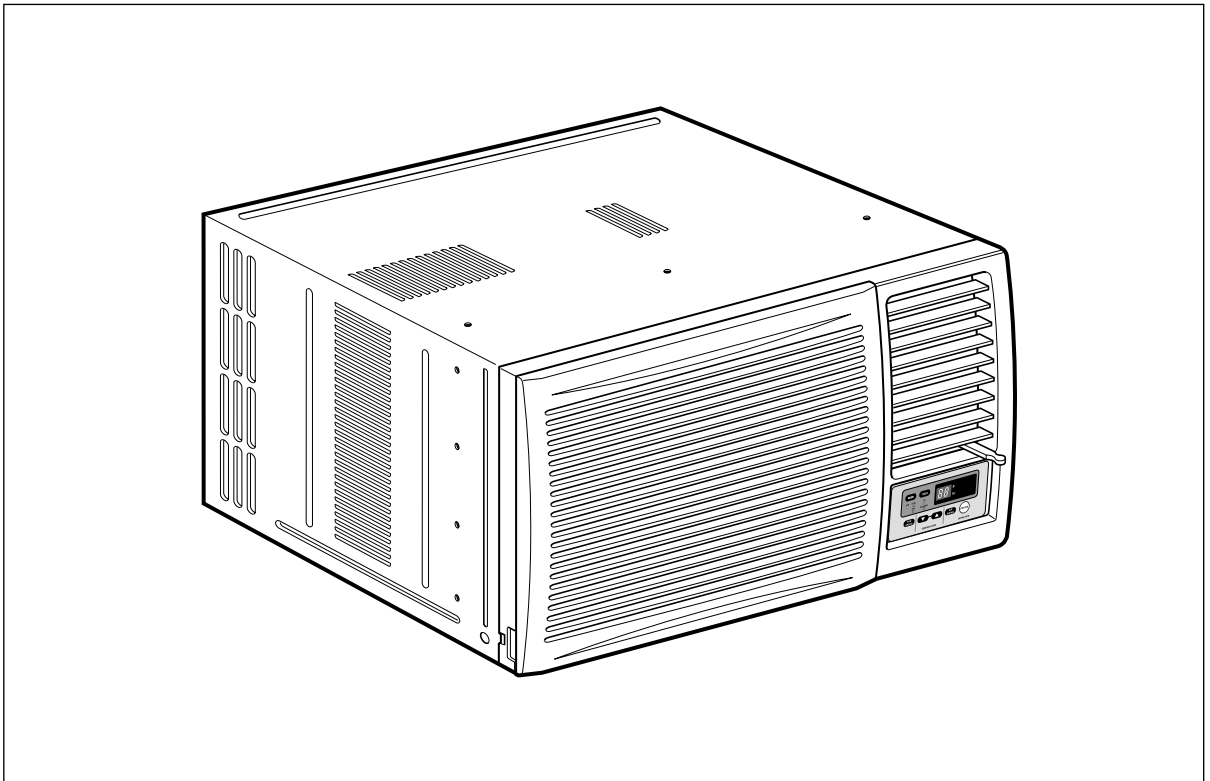

Room Air Conditioner

## INSTALLATION AND OPERATING INSTRUCTIONS

Model: **HQ-2244UH**



Please read these operating instructions thoroughly before using your air conditioner and keep for future reference.

For assistance, please call: 1-800-211-PANA(7262) or  
Register your product at : <http://www.panasonic.com/register>

**Safety Precautions**

Safety Precautions .....3



**FOR YOUR RECORDS**

Staple your receipt to this page in case you need it later.  
Write down the model and serial numbers here:

**Model #**

**Serial #**

You can find them on a label on the side of each unit.

**Dealer's Name**

**Date Purchased**

**About the Controls on the Air Conditioner**

Controls .....5  
Ventilation .....6  
Air Direction .....6  
How to Secure Drain Pipe..6

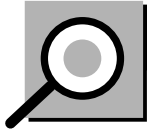

**READ THIS MANUAL**

Inside you will find many helpful hints on how to use and maintain your air conditioner properly. Just a little preventive care on your part can save you a great deal of time and money over the life of your air conditioner.

You'll find many answers to common problems in the chart of troubleshooting tips. If you review our chart of **Troubleshooting Tips** first, you may not need to call for service at all.

**Features**

Features .....8

**Installation**

How to Install the Unit .....9  
Window Requirements .....9  
Installation Kit Contents ...10  
Suggested Tool Requirements .....11  
Cabinet Installation .....12  
Electrical Data .....14  
Electrical Safety .....14



**CAUTION**

- Contact the authorized Service technician for repair or maintenance of this unit.
- The air conditioner is not intended for use by young children or infirm persons without supervision.
- Young children should be supervised to ensure that they do not play with the air conditioner.

**Before you call for service...**



Normal Operation .....15  
Abnormal Operation .....15





# Safety Precautions

To prevent injury to the user or other people and property damage, the following instructions must be followed.

■ Incorrect operation due to ignoring of instruction will cause harm or damage. The seriousness is classified by the following indications.

	<b>WARNING</b> : This symbol indicates the possibility of death or serious injury.
	<b>CAUTION</b> : This symbol indicates the possibility of injury or damage to property only.

■ Meanings of symbols used in this manual are as shown below.

	<b>Be sure not to do this.</b>
	<b>Be sure to follow the instructions.</b>

 **WARNING**

**Plug in the power plug properly.**

- Otherwise, it will cause electric shock or fire due to heat generation.

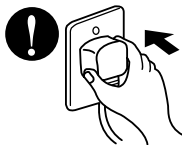

**Do not operate or stop the unit by inserting or pulling out the power plug.**

- It will cause electric shock or fire due to heat generation.

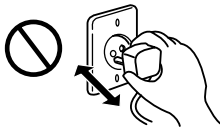

**Do not damage or use an unspecified power cord.**

- It will cause electric shock or fire.
- If the power cord is damaged, it must be replaced by the manufacturer or an authorized service center or a similarly qualified person in order to avoid a hazard.

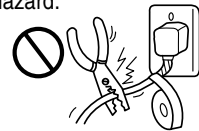

**Do not modify power cord length or share the outlet with other appliances.**

- It will cause electric shock or fire due to heat generation.

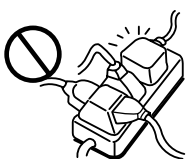

**Do not operate with wet hands or in a damp environment.**

- It will cause electric shock.



**Do not direct air flow at room occupants.**

- This could lead to health problems.

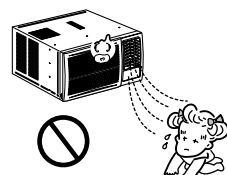



**CAUTION**

When the air filter is to be removed, do not touch the metal parts of the unit.

- It may cause an injury.

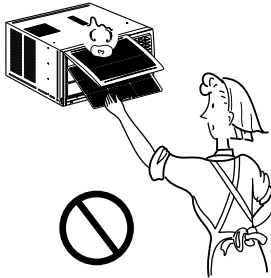

Do not clean the air conditioner with water.

- Water may enter the unit and degrade the insulation. It may cause an electric shock.

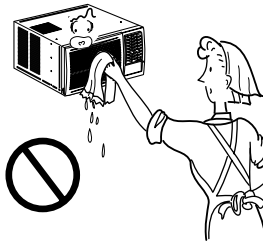

Ventilate well when used together with a stove, etc.

- An oxygen shortage may occur.

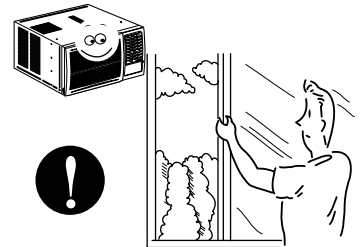

When the unit is to be cleaned, switch off, and turn off the breaker.

- Since the fan rotates at high speed during operation, it may cause an injury.

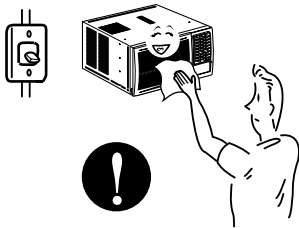

Do not put a pet or house plant where it will be exposed to direct air flow.

- This could injure the pets or plants.

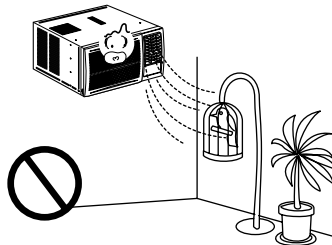

Do not use for special purposes.

- Do not use this air conditioner to preserve precision devices, food, pets, plants, and art objects. It may cause deterioration of quality, etc.

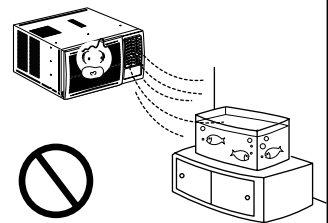

Do not operate switches with wet hands.

- It may cause an electric shock.

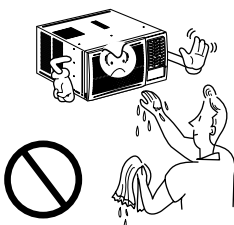

Do not apply an insecticide or flammable spray.

- It may cause a fire or deformation of the cabinet.

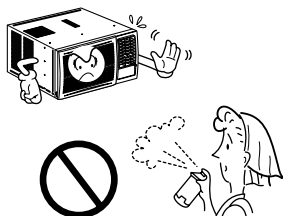

Do not put a heater, etc. where it is exposed to direct air flow.

- It may cause imperfect combustion.

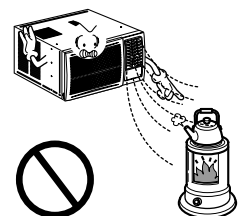

# About the Controls on the Air Conditioner



## Controls

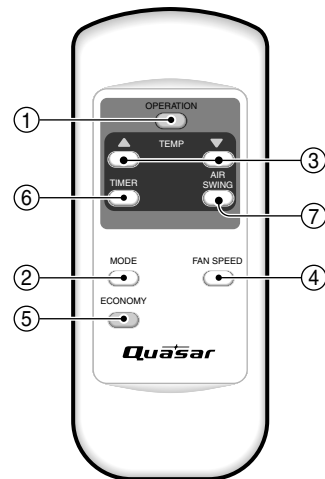
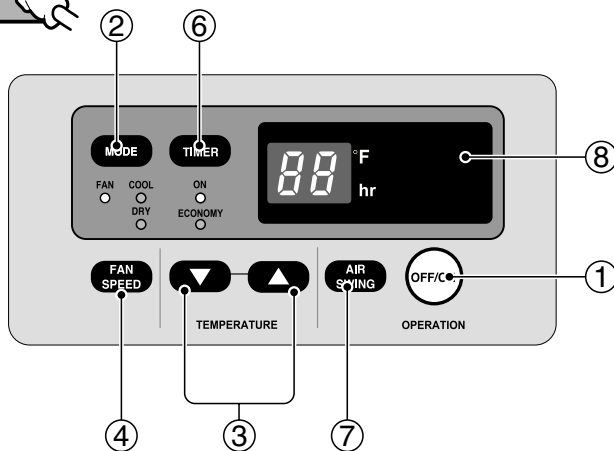

**Precaution:** The Remote Controller will not function properly if strong light strikes the sensor window of the air conditioner or if there are obstacles between the Remote Control unit and the air conditioner.

### 1 OPERATION BUTTON

- To turn the air conditioner ON, push the button. To turn the air conditioner OFF, push the button again.
- This button takes priority over any other buttons.
- When you first turn it on, the air conditioner is on the High cool mode and the temp. at 72°F(22°C)

### 2 OPERATION MODE SELECTION BUTTON

Every time you push this button. It will toggle between COOL, ECONOMY, FAN and DRY.

### 3 ROOM TEMPERATURE SETTING BUTTON

This button can automatically control the temperature of the room. The temperature can be set within a range of 60°F to 86°F by 1°F. (16°C to 30°C by 1°C)  
Select the lower number for lower temperature of the room.

### 4 FAN SPEED SELECTION BUTTONS

Every time you push this button, it is set as follows.  
{High(F3) → Low(F1) → Med(F2) → High(F3)...}.

### 5 ECONOMY

- If you push the button, the fan stops when the compressor stops cooling. Approximately every 3 minutes the fan will turn on and check the room air to determine if cooling is needed.

### 6 ON/OFF TIMER BUTTON

You can set the time when the unit will turn on or turn off automatically by pressing the timer button. If the unit is operating, this button controls the time it will be turned off. If the unit is in off state, this button controls the time it will start. Every time you push this button, the remaining time will be set as follows.

#### - STOPPING OPERATION

- Every time you push this button, when the air conditioner is operating, timer is set as follows.  
(1Hour → 2Hours → 3Hours → 4Hours → 5Hours → 6Hours → 7Hours → 8Hours → 9Hours → 10Hours → 11Hours → 12Hours → 0Hour → 1Hour → 2Hours → ...)
- The Setting Temperature will be raised by 2°F(1°C) 30min. later and by 2°F(1°C) after another 30 min.

#### - STARTING OPERATION

- Every time you push this button, when the air conditioner is not operating, timer is set as follows. (1Hour → 2Hours → 3Hours → 4Hours → 5Hours → 6Hours → 7Hours → 8Hours → 9Hours → 10Hours → 11Hours → 12Hours → 0Hour → 1Hour → 2Hours → ...)

### 7 AIR SWING BUTTON

This button can automatically control the air flow direction.

### 8 REMOTE CONTROL SIGNAL RECEIVER

### 9 DRY

- When this unit is in dry mode, the fan rotates in low speed. The fan stops when the compressor stops cooling. Approximately every 3 minutes the fan will turn on and the unit checks the room air temperature to set itself.

## Additional controls and important information.

### Ventilation

The ventilation lever must be in the CLOSE position in order to maintain the best cooling conditions.

When fresh air is necessary in the room, set the ventilation lever to the OPEN position.

The damper is opened and room air is drawn out.

**NOTE:** Before using the ventilation feature, and prior to installing the front grille, pull down part (A) until level with part (B).

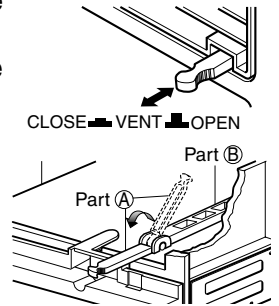

### Air Direction

The direction of air can be controlled wherever you want to cool by adjusting the horizontal louver and the vertical louver.

#### • VERTICAL AIR-DIRECTION CONTROL

#### • HORIZONTAL AIR-DIRECTION CONTROL

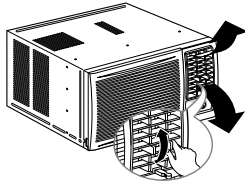

The vertical air direction is adjusted by rotating the horizontal louver forward or backward manually.

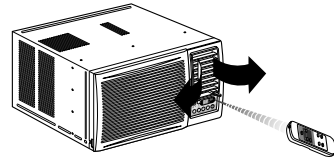

The horizontal air direction is adjusted by rotating the vertical louver right or left by Remote Controller.

### How to Secure the Drain Pipe

In humid weather, excess water may cause the BASE PAN to overflow. To drain the water, remove the DRAIN CAP and secure the DRAIN PIPE to the rear hole of the BASE PAN. Press the drain pipe into the hole by pushing down and away from the fins to avoid injury. (See Fig.1)

#### Optional(CW3H02502C)

1. Remove the rubber plug and slide the chassis out from the cabinet. (See Fig.2)
2. Install the drain pan over the corner of the cabinet where you removed the plug with 4 screws. (See Fig.3)
3. Connect the drain hose to the outlet located at the bottom of the drain pan. You can purchase the drain hose or tubing locally to satisfy your particular needs. (Drain hose is not supplied). (See Fig.3)
4. Select the most appropriate connection from among the figures to the right (by considering the hole of the unit) to fit drain pan to your own unit. (See Fig.3)
5. Slide the chassis back into the cabinet. Reinstall the cabinet screws. Secure the cabinet to chassis by using screws. (See Fig.4)

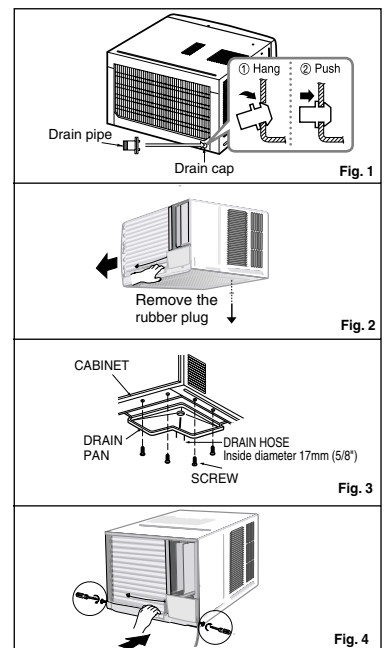

# Care and Maintenance

TURN THE AIR CONDITIONER OFF AND REMOVE THE PLUG FROM THE POWER OUTLET.

## Air Filter Cleaning

The air filter behind the front grille should be checked and cleaned at least once every 2 weeks or more often if necessary.

The grille is designed to clean the filter both upward and downward.

### TO REMOVE:

1. Open the inlet grille upward by pulling out the bottom of the inlet grille or downward by pulling out the top of the inlet grille.
2. Using the tab, pull up slightly on the filter to release it and pull it down or up.
3. Clean the filter with warm, soapy water under 40°C (104°F).
4. Rinse and gently shake the water from the filter and let it dry before replacing it.

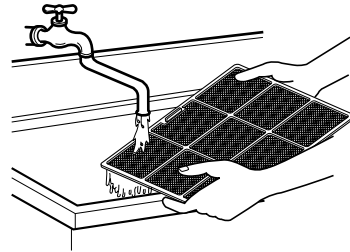
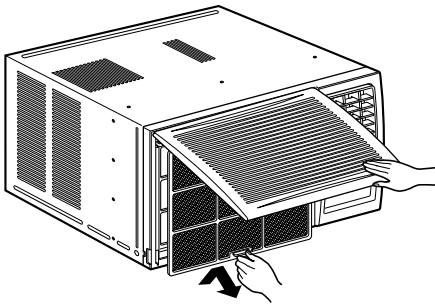

**CAUTION:** DO NOT operate the air conditioner without a filter because dirt and lint will clog it and reduce performance.

# Features

Learning parts name prior to installation will help you understand the installation procedure.

## Features

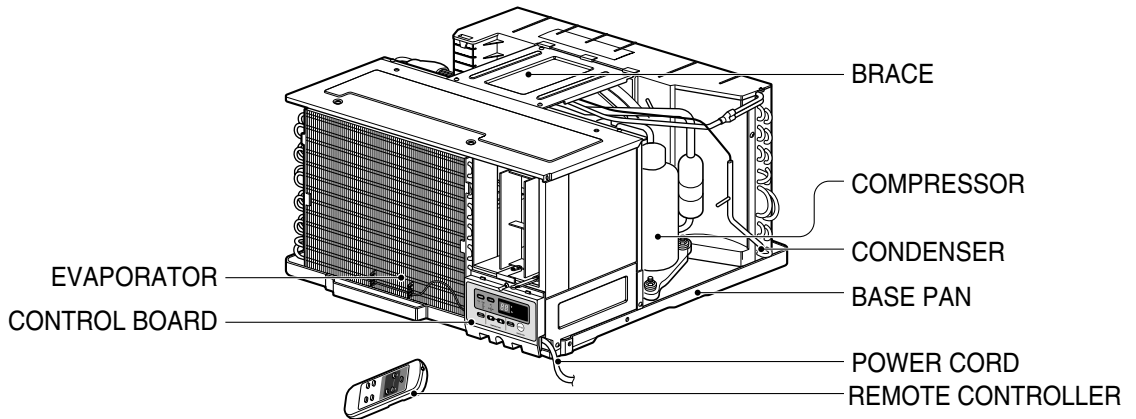
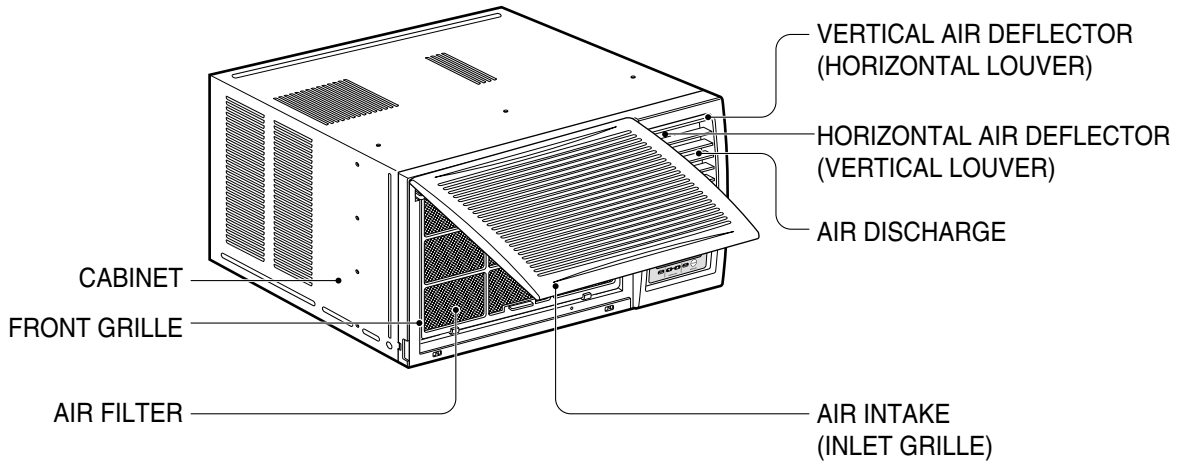



# Installation

## How to Install the Unit

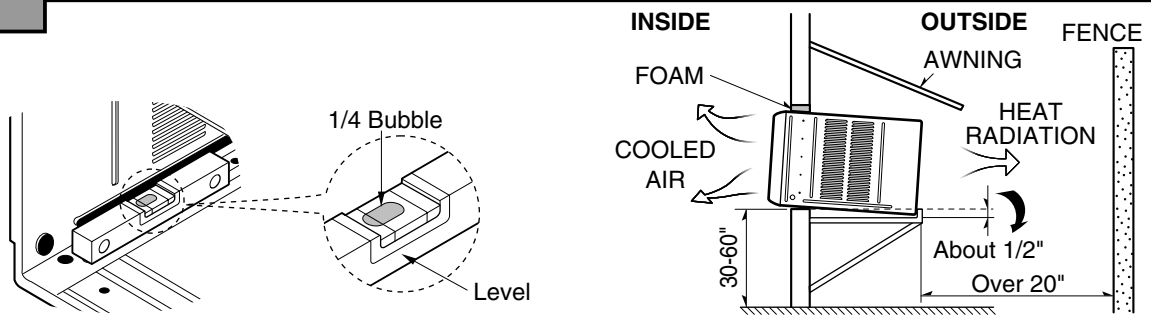

1. To avoid vibration and noise, make sure the unit is installed securely and firmly.
2. Install the unit where the sunlight does not shine directly on the unit.  
If the unit receives direct sunlight, build an awning to shade the cabinet.
3. There should be no obstacle, like a fence, within 20" which might restrict heat radiation from the condenser.
4. To prevent reducing performance, install the unit so that louvers of the cabinet are not blocked.
5. Install the unit a little obliquely outward not to avoid leaking the condensed water into the room (about 1/2" or 1/4 bubble with level).
6. Install the unit with its bottom portion 30~60" above the floor level.
7. Stuff the foam between the top of the unit and the wall to prevent air and insects from getting into the room.
8. The power cord must be connected to an independent circuit. The green wire must be grounded.
9. Connect the drain tube to the base pan hole in the rear side if you need to drain (consult a dealer.)  
Plastic hose or equivalent may be connected to the drain tube.

## Window Requirements

NOTE: All supporting parts should be secured to firm wood, masonry, or metal.

### WINDOW REQUIREMENTS

1. This unit is designed for installation in standard double hung windows with actual opening widths from 26" to 41".  
The top and bottom window sashes must open sufficiently to allow a clear vertical opening of 18" from the bottom of the upper sash to the window stool.
2. The stool offset (height between the stool and sill) must be less than 1 1/4".

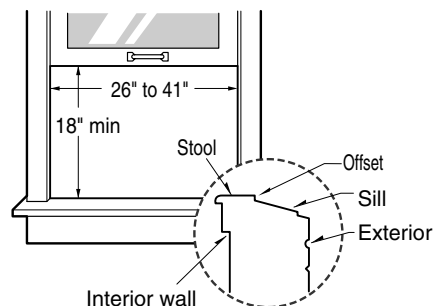

# Installation Kits Contents

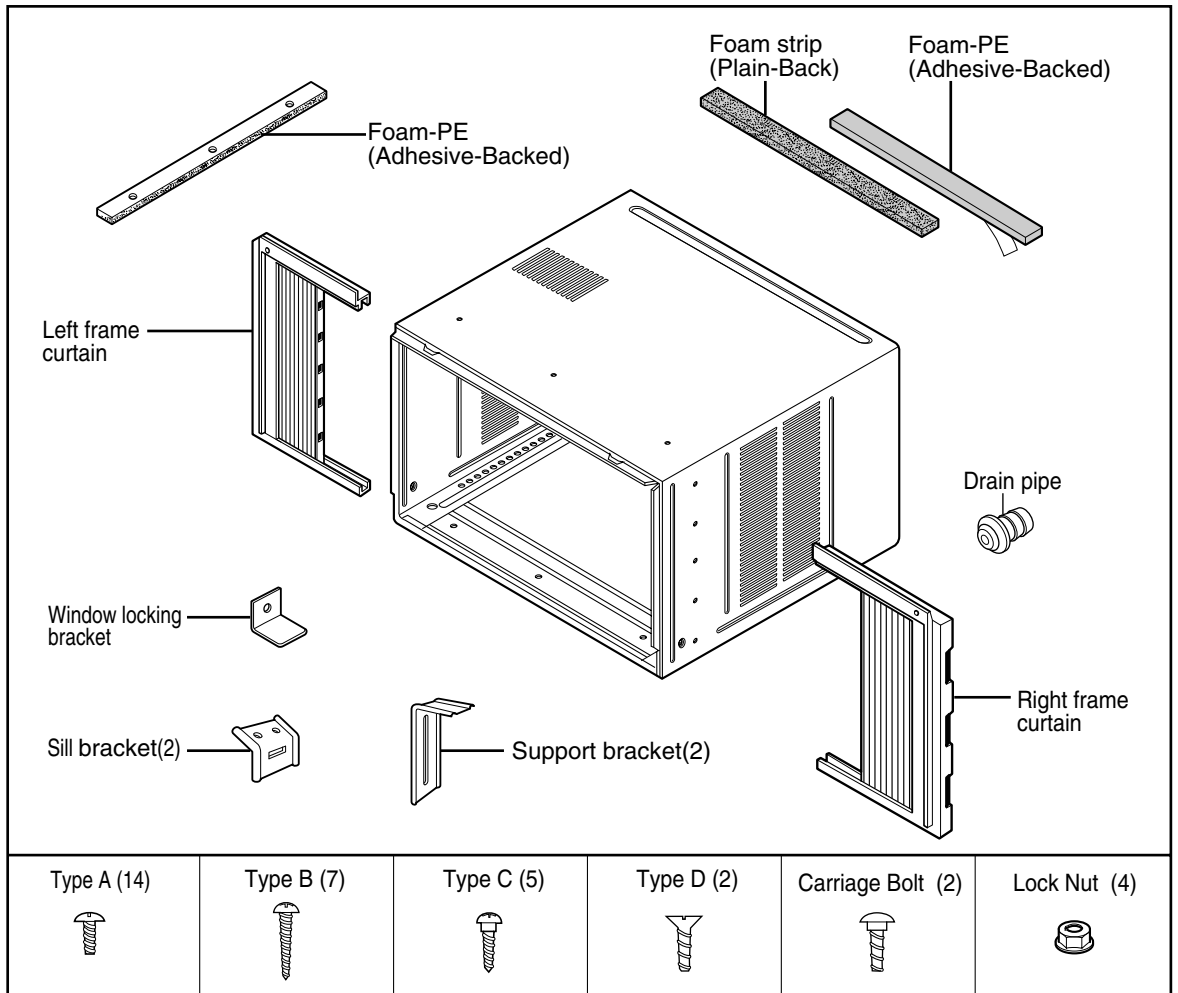

■ Top retainer bar is in product package.

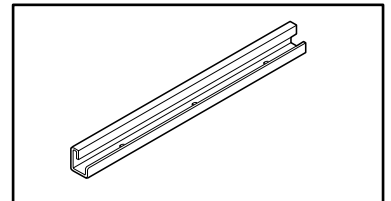

## Suggested Tool Requirements

### SCREWDRIVER(+, -), RULER, KNIFE, HAMMER, PENCIL, LEVEL

#### PREPARATION OF CHASSIS

1. Remove the screws which fasten the cabinet at both sides and at the back.(See Fig. 1)
2. Slide the unit out from the cabinet by gripping the base pan handle and pulling forward while bracing the cabinet.(See Fig. 2)
3. Cut the window sash seal to the proper length. Peel off the backing and attach the Foam-PE to the underside of the window sash.(See Fig. 3)
4. Remove the backing from Foam-PE with 3 holes and attach it to the bottom of the Top retainer bar.(See Fig. 4)
5. Attach the Top retainer bar on the top of the cabinet with 3 screws (Type A).(See Fig. 4)
6. Insert the Frame Curtain into the Top retainer bar and Lower guides.(See Fig. 4)
7. Fasten the curtains to the unit with 10 screws (Type A) at both sides.(See Fig. 4)

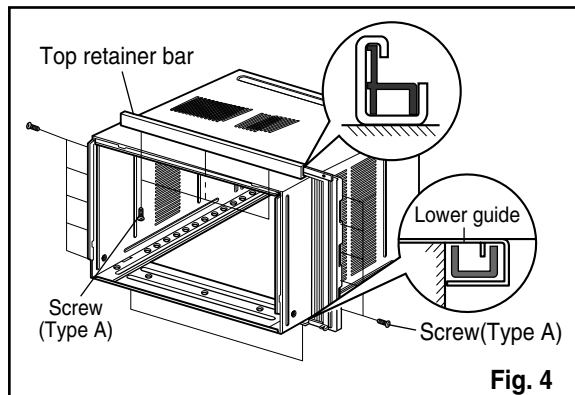
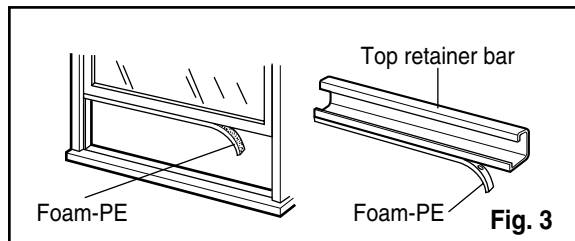
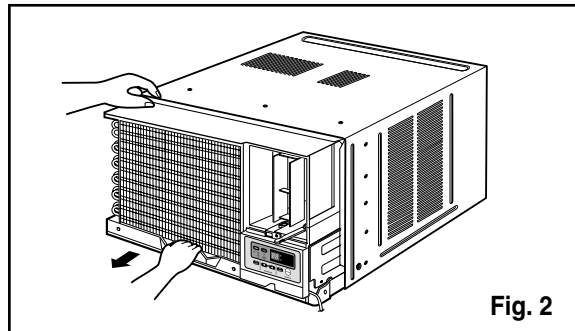
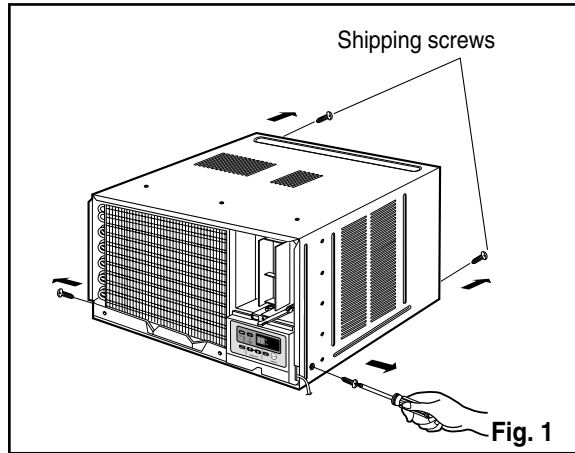

## Cabinet Installation

1. Open the window. Mark a line on the center of the window stool between the side window stop moldings.

Loosely attach the sill bracket to the support bracket using the carriage bolt and the lock nut. (See Fig. 5)

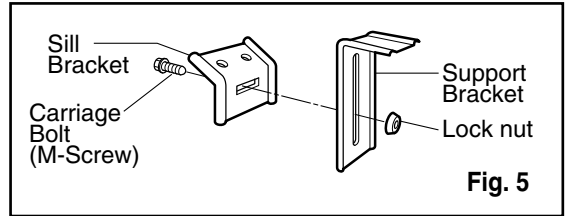

2. Attach the sill bracket to the window sill using the screws (Type B).

Carefully place the cabinet on the window stool and align the center mark on the bottom front with the center line marked window stool. (See Fig. 6)

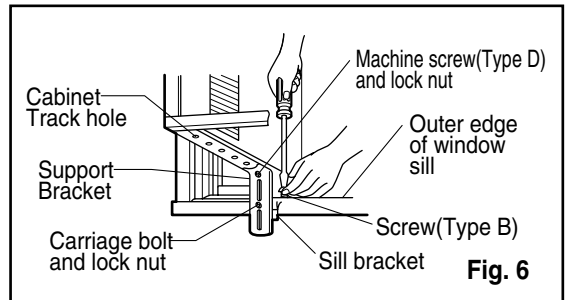

3. Using the M-screw and the lock nut, attach the support bracket to the cabinet track hole. Use the first track hole after the sill bracket on the outer edge of the window sill. Tighten the carriage bolt and the lock nut. Be sure the cabinet slants outward. (See Fig. 6)

**CAUTION: DO NOT DRILL A HOLE IN THE BOTTOM PAN.**  
The unit is designed to operate with approximately 12.7mm(1/2") of water in bottom pan.

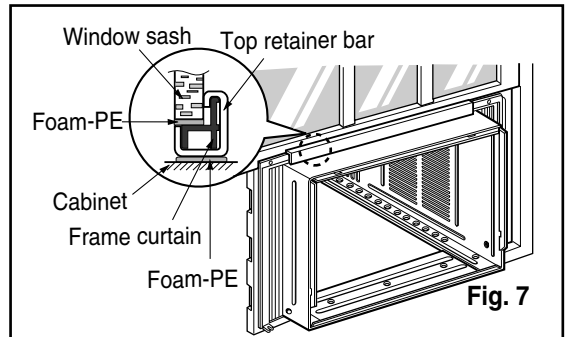

4. Pull the bottom window sash down behind the Top retainer bar until they meet. (See Fig. 7)

**NOTE:** 1. Do not pull the window sash down so tightly that the movement of Frame curtain is restricted. Attach the cabinet to the window stool by driving the screws (Type B) through the cabinet into window stool. (See Fig. 8)

2. The cabinet should be installed with a very slight tilt downward toward the outside.

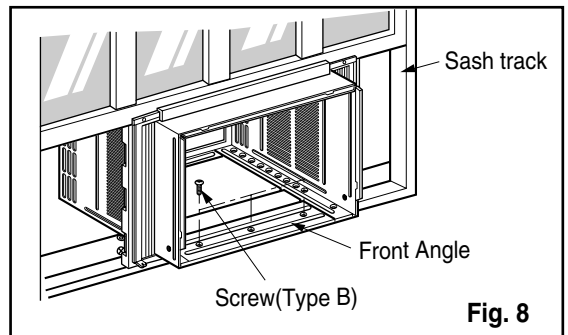

5. Pull each Frame curtain fully to each window sash track, and pull the bottom window sash down behind the Top retainer bar until it meets.

6. Attach each Frame curtain the window sash by using screws (Type C.) (See Fig. 9)

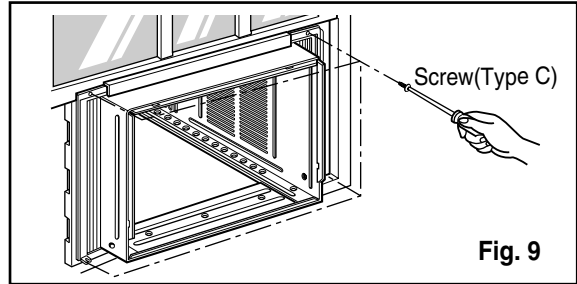

7. Slide the unit into the cabinet.(See Fig. 10)

**CAUTION:** For security purpose, reinstall screws at cabinet's sides.

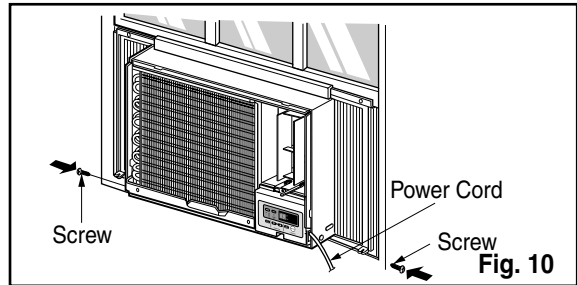

8. Cut the Foam-strip to the proper length and insert between the upper window sash and the lower window sash.(See Fig. 11)

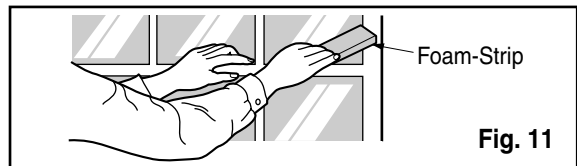

9. Attach the Window locking bracket with a screw (Type C.) (See Fig. 12)

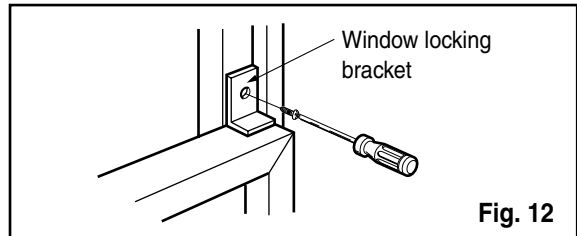

10. Attach the front grille to the cabinet by inserting the tabs on the grille into the tabs on the front of the cabinet. Push the grille in until it snaps into place.(See Fig.13)

**NOTE:** Please refer p.6 for setting ventilation kit.

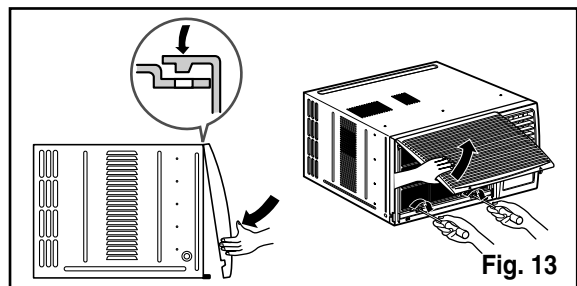

11. Lift the inlet grille and secure it with two screw (Type A) through the front grille.(See Fig. 13)

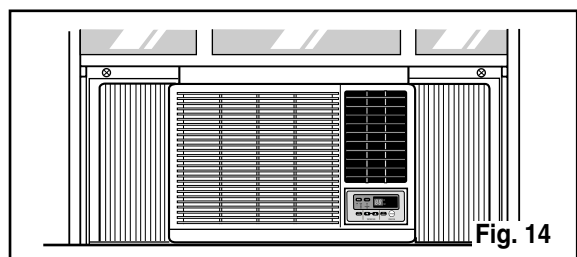

12. **Window installation of room air conditioner is now completed. See ELECTRICAL DATA for attaching power cord to electrical outlet.**

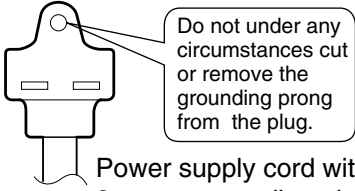

## Electrical Data(For 230/208V model only)

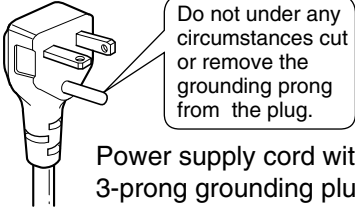
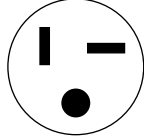
Line Cord Plug	Use Wall Receptacle	Power Supply
 <p>Power supply cord with 3-prong grounding plug</p>	 <p>Standard 250V, 3-wire grounding receptacle rated 15A, 250V AC</p>	<p>Use 15 AMP. time delay fuse or 15 AMP. circuit breaker.</p>
 <p>Power supply cord with 3-prong grounding plug</p>	 <p>Standard 250V, 3-wire grounding receptacle rated 20A, 250V AC</p>	<p>Use 20 AMP. time delay fuse or 20 AMP. circuit breaker.</p>

All wiring should be made in accordance with local electrical codes and regulations.

**NOTE :** Aluminum house wiring may pose special problems. Consult a qualified electrician.

### ■ ELECTRICAL SAFETY

#### **IMPORTANT GROUNDING INSTRUCTIONS**

Air conditioner has a three-prong grounding plug on its power supply cord, which must be plugged into properly grounded three-prong wall receptacle for your protection against possible shock hazard.

#### **230, 208, and 230/208 VOLT UNITS**

These units are equipped with a three-prong grounding plug on the power supply cord, which must be plugged into a matching properly grounded three-prong wall receptacle for your protection against possible shock hazard. If such an outlet is not present, one must be installed by a qualified electrician in accordance with the National Electrical Code and local codes and ordinances.

**NOTE:** DO NOT USE AN EXTENSION CORD ON 230, 208, AND 230/208 VOLT UNITS.

# Before you call for service...

## Troubleshooting Tips

Save time and money! Review the chart below first and you may not need to call for service.

## Normal Operation

- You may hear a pinging noise caused by water being picked up and thrown against the condenser on rainy days or when the humidity is high. This design feature helps remove moisture and improve efficiency.
- You may hear the relay click when the compressor cycles on and off.
- Water will collect in the base pan during high humidity or on rainy days. The water may overflow and drip from the outdoor side of the unit.
- The fan may run even when the compressor does not.

## Abnormal Operation

<i>Problem</i>	<i>Possible Causes</i>	<i>What To Do</i>
<b>Air conditioner does not start</b>	■ <i>The air conditioner is unplugged.</i>	• Make sure the air conditioner plug is pushed completely into the outlet.
	■ <i>The fuse is blown/circuit breaker is tripped.</i>	• Check the house fuse/circuit breaker box and replace the fuse or reset the breaker.
	■ <i>Power failure.</i>	• When power is restored, wait 3 minutes to restart the air conditioner to prevent tripping of the compressor overload.
<b>Air conditioner does not cool as it should</b>	■ <i>Airflow is restricted.</i>	• Make sure there are no curtains, blinds, or furniture blocking the front of the air conditioner.
	■ <i>TEMP Control set to a higher number.</i>	• Set the TEMP Control to a lower number.
	■ <i>The air filter is dirty.</i>	• Clean the filter at least every 2 weeks. See the operating instructions section.
	■ <i>The room may have been hot.</i>	• When the air conditioner is first turned on you need to allow time for the room to cool down.
	■ <i>Cold air is escaping.</i>	• Check for open furnace floor registers and cold air returns. • Set the air conditioner's vent to the closed position.
	■ <i>Cooling coils have iced up.</i>	• See Air Conditioner Freezing Up below.
<b>Air conditioner freezing up</b>	■ <i>Ice blocks the air flow and stops the air conditioner from cooling the room.</i>	• Set the mode control at <b>High Fan</b> or <b>High Cool</b> with the high temperature.

**Panasonic Consumer Electronics Company,  
Division of Matsushita Electric Corporation  
of America**

One Panasonic Way  
Secaucus, New Jersey 07094

**Panasonic Sales Company,  
Division of Matsushita Electric of Puerto Rico, Inc.,**  
Ave. 65 de Infanteria, Km. 9.5  
San Gabriel Industrial Park  
Carolina, Puerto Rico 00985

## **Panasonic Room Air Conditioner Limited Warranty**

Panasonic Consumer Electronics Company or Panasonic Sales Company (collectively referred to as "the Warrantor") will repair this product with new or refurbished parts in case of defects in material or workmanship, free of charge, in the USA or Puerto Rico in accordance to the following (All time periods start from the date of the original purchase).

**SEALED REFRIGERATING SYSTEM (compressor and interconnecting tube): FIVE (5) YEARS - PARTS AND LABOR**

**ALL OTHER COMPONENTS: ONE (1) YEAR - PARTS AND LABOR**

**In-home service** in the USA can be obtained during the warranty period by contacting a Panasonic Service Company (PASC) Factory Servicenter listed in the Servicenter Directory. Or call toll free, 1-800-211-PANA(7262), to locate a PASC authorized Servicenter. In-home service in Puerto Rico can be obtained during the warranty period by calling the Panasonic Sales Company telephone number listed in the Servicenter Directory.

Note: If the unit is installed at the other than normal window height and/or has been custom-installed (e.g., through the wall), the customer is responsible for removing the unit from its installation prior to the performance of in-home service.

This warranty is extended only to the original purchaser. A purchase receipt or other proof of date of the original purchase is required for service and parts replacement under this warranty.

This warranty only covers failures due to defects in materials and workmanship and does not cover normal wear or cosmetic damage. The warranty does not cover damages which occur in shipment, or failures which are caused by products not supplied by the warrantor, or failures which result from accident, misuse, abuse, neglect, mishandling, misapplication, faulty installation, maladjustment of customer controls, improper maintenance, alteration, modification, power line surge, lightning damage, improper voltage supply, commercial use such as hotel, office, restaurant, or other business or rental use of the product, or service by anyone other than a PASC Factory Servicenter or a PASC authorized Servicenter, or damage that is attributable to acts of God.

### **LIMITS AND EXCLUSIONS**

There are no express warranties except as listed above.

THE WARRANTOR SHALL NOT BE LIABLE FOR INCIDENTAL OR CONSEQUENTIAL DAMAGES RESULTING FROM THE USE OF THIS PRODUCT, OR ARISING OUT OF ANY BREACH OF THIS WARRANTY ALL EXPRESS AND IMPLIED WARRANTIES, INCLUDING THE WARRANTIES OF MERCHANTABILITY, ARE LIMITED TO THE APPLICABLE WARRANTY PERIOD SET FORTH ABOVE.

Some states do not allow the exclusion or limitation of incidental or consequential damages or limitations on how long an implied warranty lasts, so the above exclusions or limitations may not apply to you.

This warranty gives you specific legal rights and you may also have other rights which vary from state to state. If a problem with this product develops during or after the warranty period, you may contact your dealer or Servicenter. If the problem is not handled to your satisfaction, then write to the Consumer Affairs Department at the company address indicated above.

SERVICE CALLS WHICH DO NOT INVOLVE DEFECTIVE MATERIALS OR WORKMANSHIP AS DETERMINED BY THE WARRANTOR, IN ITS SOLE DISCRETION, ARE NOT COVERED. COSTS OF SUCH SERVICE CALLS ARE THE RESPONSIBILITY OF THE PURCHASER.

[For assistance, please call: 1-800-211-PANA (7262) or send e-mail to [consumerproducts@panasonic.com](mailto:consumerproducts@panasonic.com)]