

SUPPLEMENTARY INSTALLATION INSTRUCTIONS

(For Contractor Pack)

Housing Can
FV-05-11VFA2

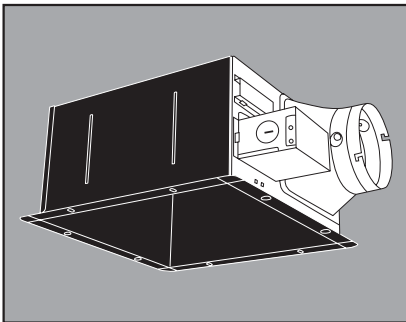

Motor/Grille Assembly
FV-05VFB2

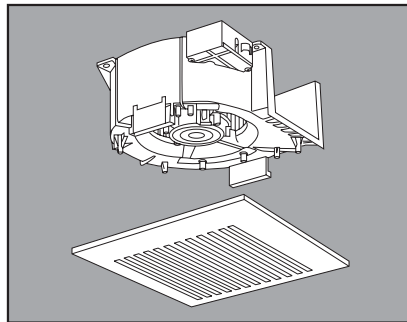

FV-08VFB2, FV-11VFB2

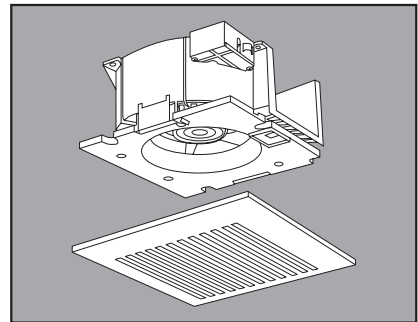

Applicable to Models: FV-05VF2, FV-08VF2, FV-11VF2

Panasonic®

READ AND SAVE THESE INSTRUCTIONS.

Please read these instructions carefully before attempting to install, operate or service the Panasonic Ventilating Fan. Failure to comply with instructions could result in personal injury and/or property damage. Please retain this booklet for future reference.

Table of Contents

General Safety Information	2
Unpacking	2
Supplied Accessories	3
Wiring diagram	3
Installation I (Joist Mounting-I)	4-5
Installation II (Joist Mounting-II)	6-7
Installation III (I-Joist Mounting)	7
Installation IV (Between Joist Mounting)	8-9
Installation V (Wooden Header)	9
Installation VI (In Existing Construction)	10
Product Service	10

GENERAL SAFETY INFORMATION

1. Do not install this ventilating fan where air temperature may exceed 40° C (104°F).
2. Make sure that the electric service supply voltage is 120 V, 60 Hz.
3. Follow all local electrical and safety codes, as well as the National Electrical Code (NEC) and the Occupation Safety and Health Act (OSHA).
4. Always disconnect the power source before working on or near the fan, motor or junction box.
5. Protect the power cord from sharp edges, oil, grease, hot surfaces, chemicals or other objects.
6. Do not kink the power cord.
7. Do not install the unit where ducts are configured as shown in Fig. A.
8. Provide suction parts with proper ventilation.
9. This unit is UL listed for use over a bathtub or shower when installed in a GFCI protected branch circuit.



Fig. A

CAUTION:

1. For general ventilating use only. Do not use to exhaust hazardous or explosive materials and vapors.
2. Not for use in cooking area. (Fig .B)
3. This product must be properly grounded.

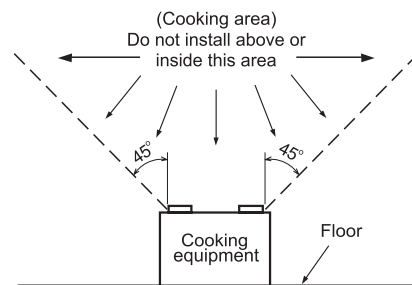

Fig. B

WARNING:

To reduce the risk of fire, electric shock or injury to persons, observe the following:

- A. Use this unit only in the manner intended by the manufacturer. If you have any questions, please contact to the manufacturer.
- B. Installation work and electrical wiring must be done by qualified person(s) in accordance with all applicable codes and standards, including fire-rated construction.
- C. Sufficient air is needed for proper combustion and exhausting of gases through the flue (chimney) of fuel burning equipment to prevent backdrafting. Follow the heating equipment manufacturer's guideline and safety standards such as those published by the National Fire Protection Association (NFPA), and the American Society for Heating Refrigeration and Air Conditioning Engineers (ASHRAE) and the local code authorities.
- D. The Housing Can FV-05-11VFA2 must be installed with Motor/Grille Assembly FV-05/08/11VFB2 only.
- E. When cutting or drilling into wall or ceiling, do not damage electrical wiring and other hidden utilities.
- F. Ducted fans must always be vented to the outdoors.
- G. These models are UL listed for tub and shower enclosures.
- H. Solid state controls may cause harmonic distortion which can cause motor humming noise. To reduce the risk of fire or electric shock, do not use this unit with any solid-state control device.
- I. Before servicing or cleaning unit, switch power off at service panel and lock the service disconnecting means to prevent power from being switched on accidentally. When the service disconnecting means cannot be locked, securely fasten a prominent warning device, such as a tag, to the service panel.
- J. NEVER place a switch where it can be reached from a tub or shower.
- K. Not to be installed in a ceiling thermally insulated to a value greater than R40. (This is required for installation in Canada only.)

UNPACKING





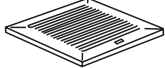

Unpack and carefully remove unit from carton.
Refer to the following Supplied Accessories list to verify that all parts are present.

SUPPLIED ACCESSORIES (4 SETS)

(A) For Motor / Grille Assembly of model: FV-05/08/11VFB2

Part name	Appearance	Quantity
Grille		4

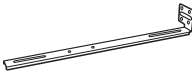
(B) For Housing Can of model: FV-05-11VFA2

Part name	Appearance	Quantity
Long screw (ST4.2X20)		24
Thumb screw		4
Screw I (ST4.2X8)		8
Screw II (ST4.2X10)		8
Suspension bracket I		4
Suspension bracket II		4
Suspension bracket III		4
3 inches adaptor connector (optional part)		4

WIRING DIAGRAM

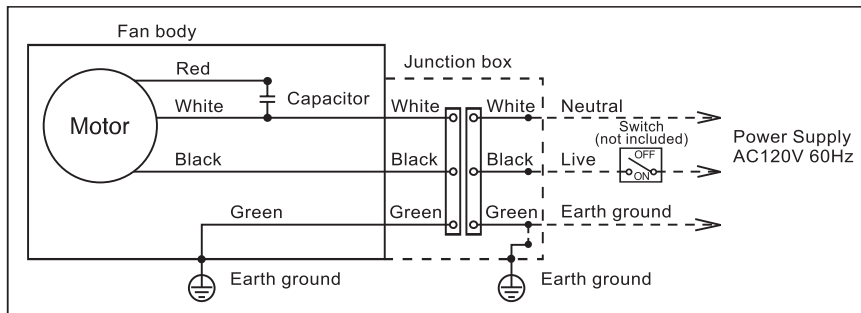

INSTALLATION I (JOIST MOUNTING-I)

1. Before installation, Secure the fan body to adaptor by using thumb screw. (Fig. 1)

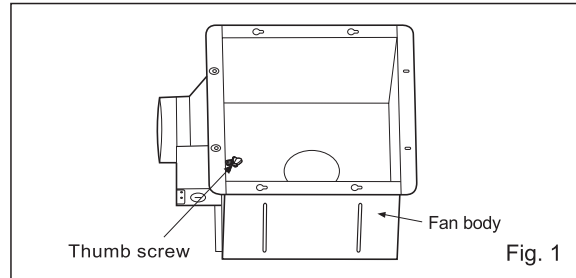
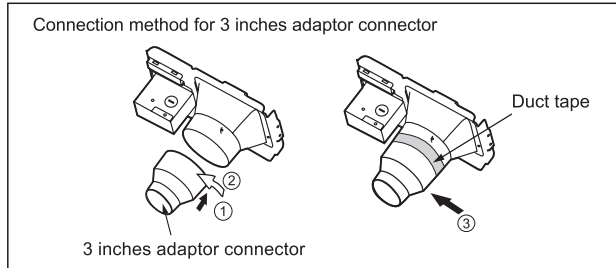

IMPORTANT:
Remove the tape from damper and adaptor before installation. As shown below:

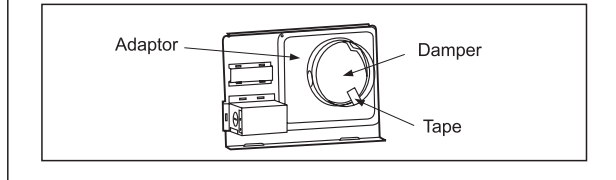

2. Insert the suspension bracket into the fan body and adaptor. (select the suspension bracket according to Fig. 2)

If spacing A on center joists is 24 inches, connect suspension bracket II and III (C4 mark to C4 mark) as shown below :

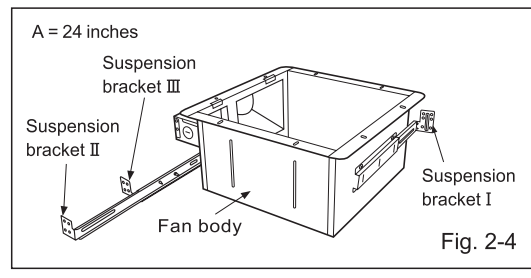
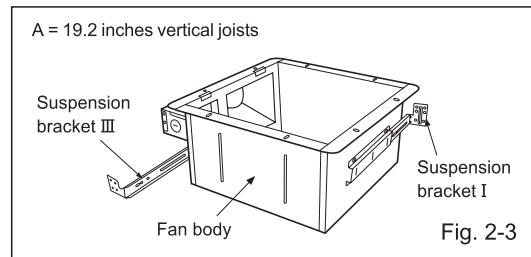
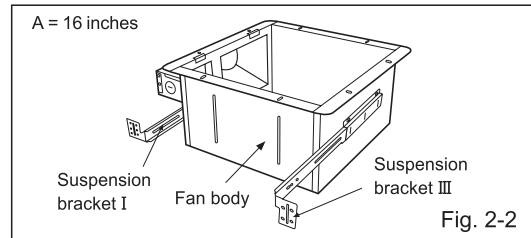
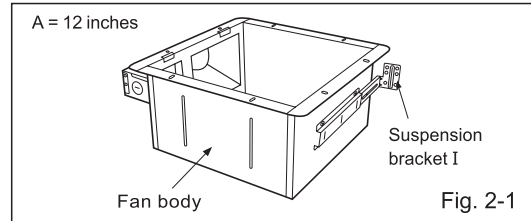
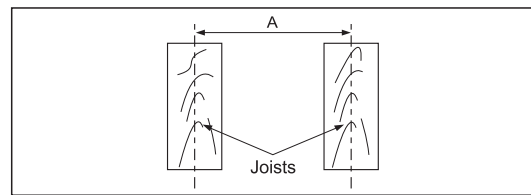
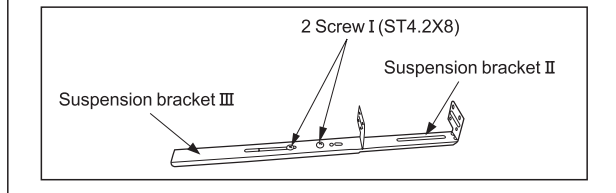

INSTALLATION I (JOIST MOUNTING-I) CONTINUED

3. Install the suspension bracket and the flange of fan body to joists by using long screws (ST4.2X20) according to Fig. 3.

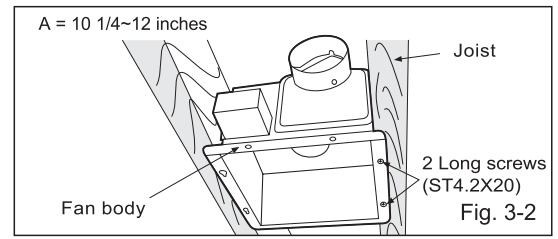
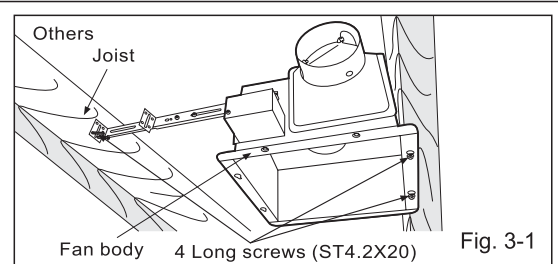

4. Install the suspension bracket to joists by using long screws (ST4.2X20) and secure it to the fan body by using screw II (ST4.2X10) (Fig. 4)
5. Remove junction box cover and secure conduit or stress relief to junction box knock-out hole. (Fig. 5)

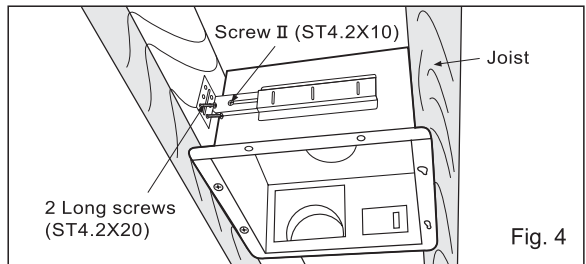

6. Refer to wiring diagram (page 3).
Using wire nuts, connect house power wires to ventilating fan wires:
black to black; white to white; green to green;
Replace the junction box cover. (Fig. 5)

CAUTION:

Mount junction box cover carefully so that lead wires are not pinched.

7. Install a duct and secure it with duct tape or clamps.

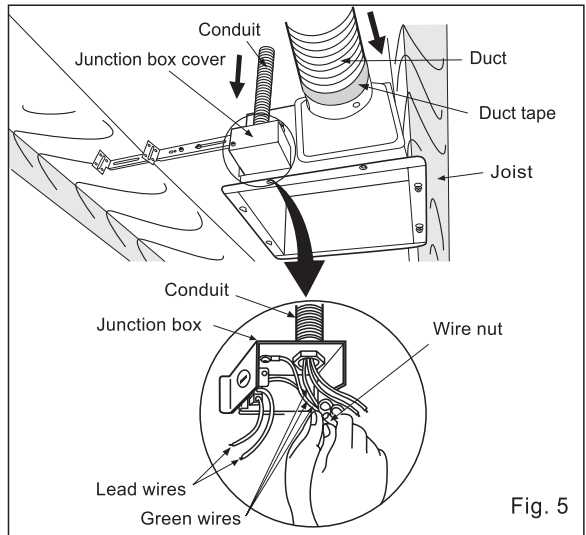

8. Finish ceiling work. Ceiling hole should be aligned with the edge of the flange. (Fig. 6)

9. Follow the Fig. 12-3, 12-4 (page 9) and Fig. 7 (page 8) of the original installation instruction to complete the motor/grille assembly installation.

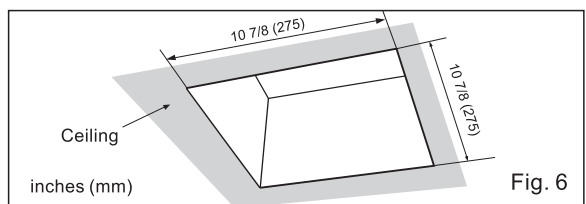

INSTALLATION II (JOIST MOUNTING-II) CONTINUED

6. Secure the fan body to adaptor by using thumb screw (Fig. 9)
7. Secure the suspension bracket to joists by using long screws (ST4.2X20) and secure it to fan body by using screw II (ST4.2X10) in vertical direction (Fig. 9)
8. Follow step 8~9 of Installation I (page 5) to complete the installation work.

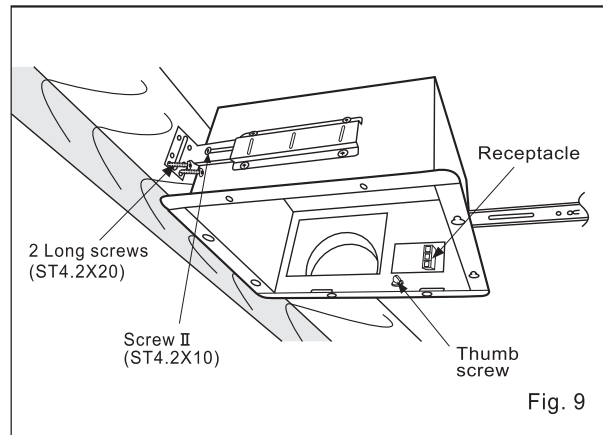

INSTALLATION III (I-JOIST MOUNTING)

4 kinds of I-joist inches (mm)	
C1	9/16 (14.3)
C2	11/16 (17.5)
C3	31/32 (24.6)
C4	1 17/32 (38.9)

Suspension bracket III
The suspension bracket III can comply with different kinds of I-joist.

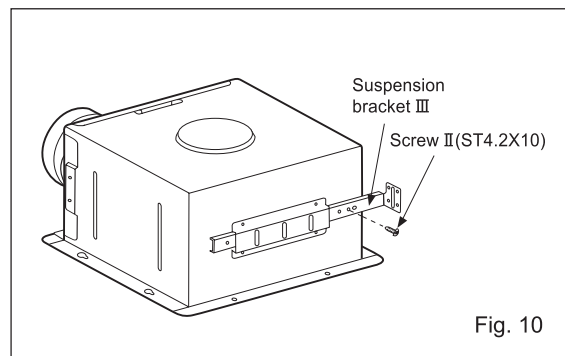

1. Before installation, secure the fan body to adaptor by using thumb screw. (Fig. 1 of page 4)
2. Connect the suspension bracket III to fan body. (Fig. 10) (select the hole by checking I-joist size fix the screw to the frame hole.)
3. Connect the fan body to the I-joist. (Fig. 11)
4. Follow step 5 to 9 of installation I (page 5) to complete the installation work.

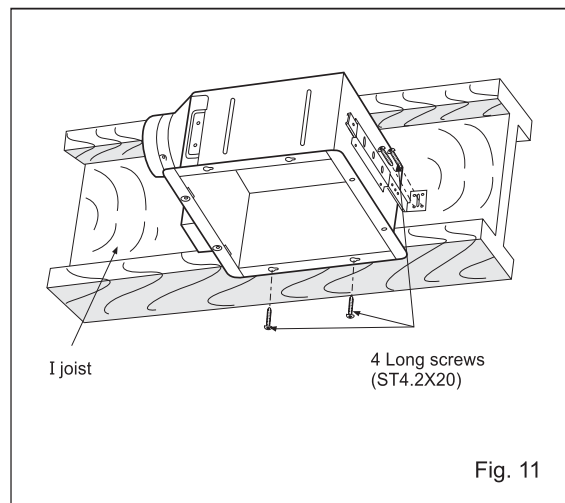

INSTALLATION IV (BETWEEN JOIST MOUNTING)

1. Before installation, secure the fan body to adaptor by using thumb screw. (Fig.1 of page 4)
2. Insert the suspension bracket into the bracket cover of adaptor side and the back of the fan body. (Fig.12)
(select the suspension bracket according to spacing A as shown below)

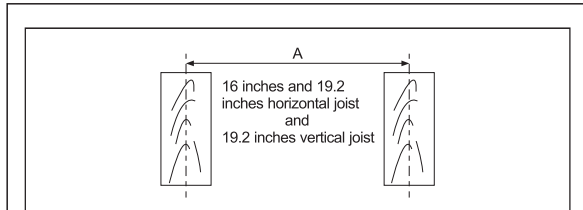

A = 16 inches and 19.2 inches horizontal joist

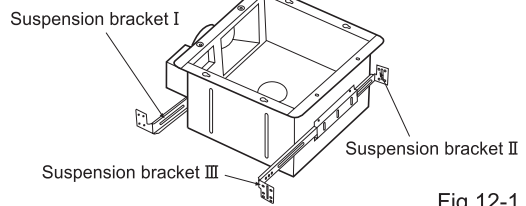

Fig.12-1

A = 19.2 inches vertical joist

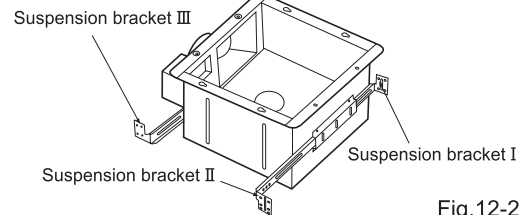

Fig.12-2

3. Insert the fan body between joists.
Make sure the fan body is level and square (perpendicular) with the joists. (Fig. 13)
Keep the distance B (7/8 inch, 21.6mm) for the thickness of ceiling board.

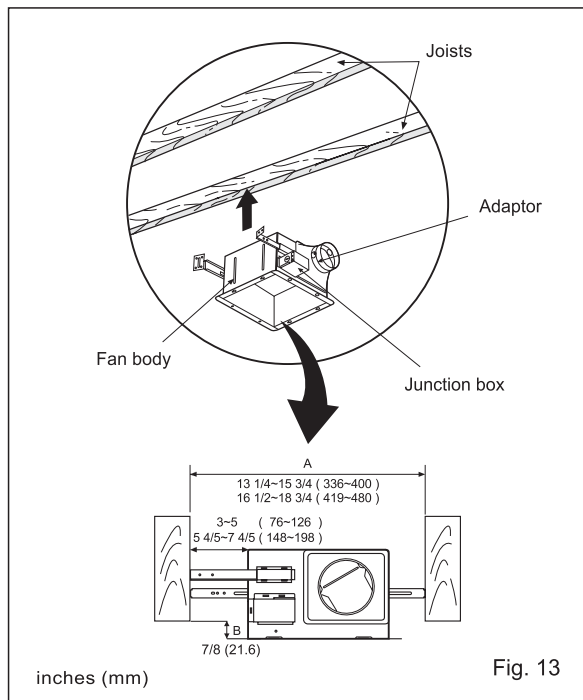
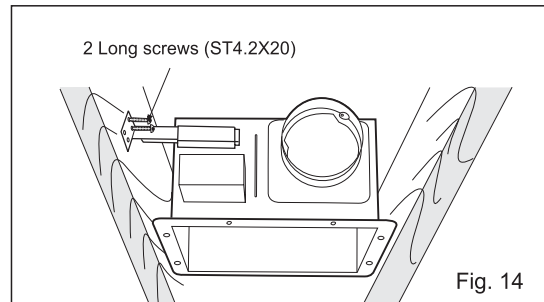

Fig. 13

INSTALLATION IV (BETWEEN JOIST MOUNTING) CONTINUED

4. Secure the suspension bracket to joists by using long screws (ST4.2X20) (Fig. 14, Fig. 15)



5. Secure the suspension bracket to fan body by using screw II (ST4.2X10) (Fig. 15)

6. Follow step 5 to 9 of installation I (page 5) to complete the installation work.

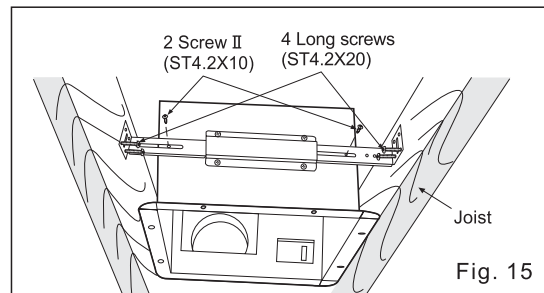

INSTALLATION V (WOODEN HEADER)

1. Before installation, secure the fan body to adaptor by using thumb screw. (Fig. 1 of page 4)

2. Install header between joists by using nails or screws.

3. Install the fan body and secure it by using long screws (ST4.2X20) (Fig. 16 of page 8, Fig. 17)

4. Follow step 5 to 9 of installation I (page 5) to complete the installation work.

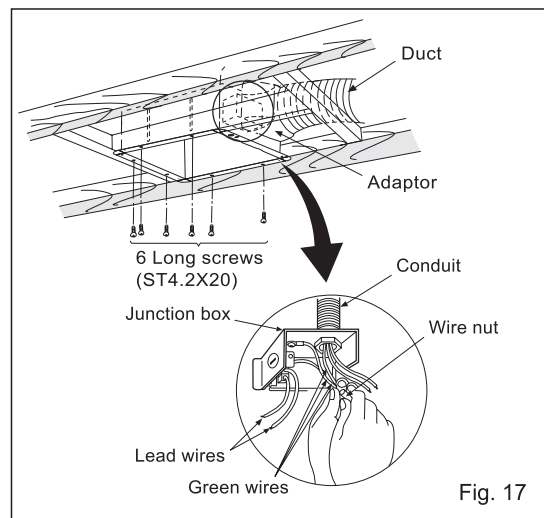
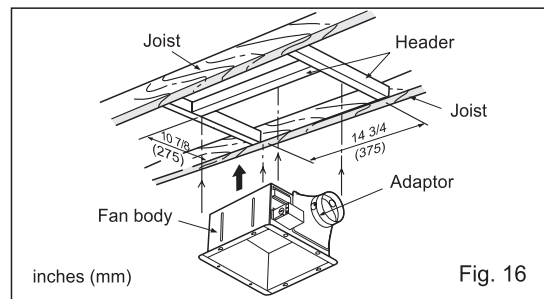

INSTALLATION VI (IN EXISTING CONSTRUCTION)

1. Installation in existing construction.

Installing the ventilating fan in an existing building requires an accessible area (attic or crawl space) above the planning installation location or existing ducting and wiring.

- (1) To install the ventilating fan, follow the procedures described in Installation II. Take the following precautions before installation.

CAUTION:

Check area above planning installation location to be sure that:

1. Duct work can be installed and that area is sufficient for proper ventilation.
2. Wiring can be run to planning location.
3. No wiring or other obstructions shall interfere with installation.

- (2) Inspect duct work and wiring before proceeding with installation.
- (3) Plan suitable location for ventilating fan. (next to ceiling joist)
- (4) Before installation, provide inspection and maintenance access at a location that will not interfere with installation work shown in installation II.
- (5) First, remove ceiling section according to Fig. 6 of page 5.
- (6) Install ventilating fan.

2. Installation from accessible area above fan location.

- (1) Inspect duct work and wiring before proceeding with installation.
- (2) Remove ceiling section according to Fig. 6 of page 5.
- (3) Install ventilating fan.

PRODUCT SERVICE

Warning Concerning Removal of Covers.

The unit should be serviced by qualified technicians only. No service information is provided for customers. Your product is designed and manufactured to ensure a minimum of maintenance. However, should your unit ever require service, a nationwide system of factory service centers and AUTHORIZED INDEPENDENT SERVICE CENTERS is maintained to support your product's warranty. (In the U.S.A., call 1-866-292-7292 to Customer call center.)

PANASONIC CONSUMER ELECTRONICS COMPANY

Division of Panasonic Corporation of North America,
One Panasonic Way, Secaucus, NJ 07094

PANASONIC CANADA INC.

5770 Ambler Drive, Mississauga, ON L4W 2T3

www.panasonic.com

X0206-2047 08VFA2420B