

This Owner's Manual is provided and hosted by [Appliance Factory Parts](#).

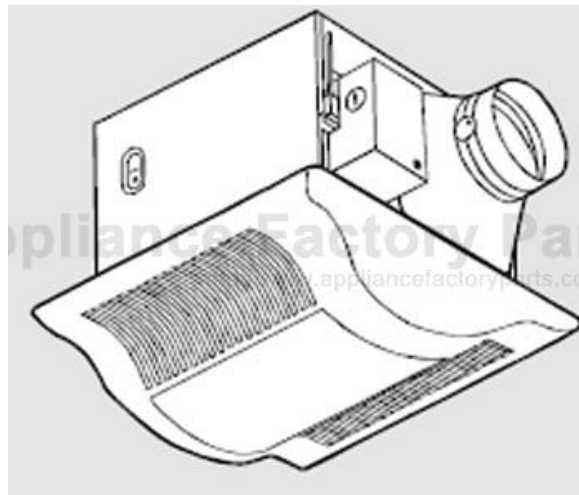

PANASONIC FV-08VKSL2 Owner's Manual

[Shop genuine replacement parts for PANASONIC
FV-08VKSL2](#)



[Find Your PANASONIC HVAC Parts - Select From 26 Models](#)

----- Manual continues below -----

Panasonic®

Ventilating Fan

INSTALLATION INSTRUCTIONS

Model No. **FV-08VKML2**
FV-08VKSL2

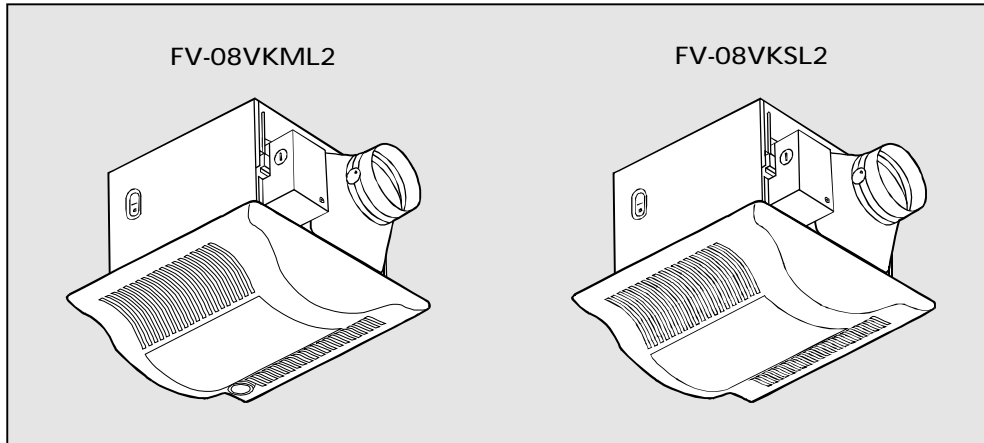

READ AND SAVE THESE INSTRUCTIONS.

Thank you very much for having purchased our Ventilating Fan.
Please read these instructions carefully before attempting to install,
operate or service the Panasonic Ventilating Fan. Failure to comply
with instructions could result in personal injury and/or property
damage. Please retain this booklet for future reference.

Table of Contents

Please Read Prior To Installing This Fan	2
Unpacking	3
Supplied Accessories	3
Description	3
Dimensions	4
Wiring Diagram	5
Switch Indication	5
Operation	6
Specifications	6
General Safety Information	7
Installation I (Joist Mounting-I)	8-10
Installation II (Joist Mounting-II)	11-12
Installation III (I-Joist Mounting)	12
Installation IV (Suspended Between Joist Mounting)	13
Installation V (Wooden Header)	14
Installation VI (In Existing Construction)	14
Maintenance	15-16
Practical Guide To Installation	16
Product Service	16

PLEASE READ PRIOR TO INSTALLING THIS FAN

The WhisperGreen™ line of ventilating fans employs state of the art technology providing a number of unique features that lead to improved indoor air quality. These features need to be fully understood prior to installation to fully realize the benefits the fans offer.

Spot and Continuous Ventilation: These fans are designed to run continuously ensuring a healthy environment at low CFM levels 24 hours a day. By utilizing **CustomVent™ Variable Speed Control** the fans are built to run continuously at a pre-set lower level (0,30,40,50,60,70 CFM). The setting is dependent on the size of the room and the individual wishes of the homeowner. ***It is crucial that the installer pre-set the lower setting during the installation. Please refer to the chart below and page 5 of the installation instructions.***

**CustomVent™ Variable Speed Control (Lower Setting)
ASHRAE 62.2-2007**

(Sq. feet)	Two Bedrooms	Three Bedrooms	Four Bedrooms	Five Bedrooms
<1,000	33	40	48	55
1,500	38	45	53	60
2,000	43	50	58	65
2,500	48	55	63	70
3,000	53	60	68	75

These fans are also built to take care of the homeowner's spot ventilation needs when the room is occupied. These models kick-up to a maximum level of 80 CFM either when the switch is turned on (FV-08VKSL2) or activated by the **SmartAction™ Motion Sensor** (available with FV-08VKML2 only).

A High/Low Delay Timer, located inside the fan body, is utilized to return the fan back to the Pre-set continuous ventilation mode. ***The installer needs to consult with the homeowner for the desired setting on the timer (0.5-60 minutes) and make the adjustments during the installation.***

Optimum Ventilation Performance: Generally duct length, elbows and other factors increase static pressure hindering the performance of most ventilation fans. These fans utilize **SmartFlow™** microchip technology that monitors the static pressure in the system and speeds up or slows down the rpm of the fan depending on the amount of resistance. This allows the fan to perform as rated, whether facing 0.1, 0.2 or even 0.25 inches water gauge. The bottom line is that it makes for easier installation. The installer no longer has to worry about compromising the fan's performance.

Outstanding Energy Savings: These fans are the very first to be built using DC motor technology. The new DC motor is 30%-70% more energy efficient than the minimum ENERGY STAR requirements.

This product contains electronic ballast with fluorescent lamps and is in compliance with Part 18 of the FCC rules as consumer RF lighting device. Operation is subject to the following two conditions: (1) This device may not cause harmful interference, and (2) this device must accept any interference received, including interference that may cause undesired operation.

This product may cause interference to radio equipment and should not be installed near maritime safety communications equipment or other critical navigation or communication equipment operating between 0.45-30 MHz. If interference should occur, try to increase spacing between this product and other product.

Doc Responsible Party: Panasonic Corporation of North American
One Panasonic Way, Secaucus, NJ 07094







Sales Company: Panasonic Home & Environment Company
Unit of Panasonic Consumer Electronic Company
One Panasonic Way, Secaucus, NJ 07094



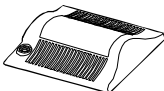

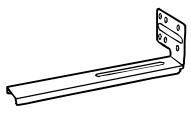
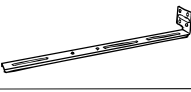
Customer Call Support: 1-866-292-7292

UNPACKING

Unpack and carefully remove unit from carton.
Refer to the Supplied Accessories list to verify that all parts are present.

SUPPLIED ACCESSORIES

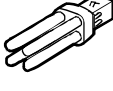
Part name	Appearance	Quantity
Grille	 FV-08VKML2	1
	 FV-08VKSL2	1
Suspension bracket I		1
Suspension bracket II		1
Suspension bracket III		1
Screw I (ST4.2X8)		2
Screw II (ST4.2X12)		2
Screw III (ST4.2X16)		1

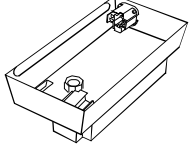
Part name	Appearance	Quantity
Machine screw (M4X8)		2
Long screw (ST4.2X20)		6
18W Fluorescent lamp		2
4W Night lamp		1
Lighting unit		1

DESCRIPTION

These Panasonic ventilating fan models use a sirocco fan with dolphin-shaped blades driven by brushless direct current motor powered by an integral transformer. The motor is designed to have long operating life, high dynamic response, higher speed ranges with saving energy. The grille covering the fan body is a spring-loaded, quick remove type. A damper for preventing air counterflow is provided. The blower uses a high-capacity sirocco fan developed to reduce the noise level.

The lighting unit is an energy-saving, lighting device uses two 18W fluorescent lamps and produces almost the same illumination as a standard 100W incandescent lamp.

Panasonic ventilating fan model FV-08VKML2 is equipped with a motion sensor that shifts the fan to high flow automatically when motion is detected. It is use-adjustable to operate 0.5-60 minutes after motion is no longer detected.

DIMENSIONS

FV-08VKML2

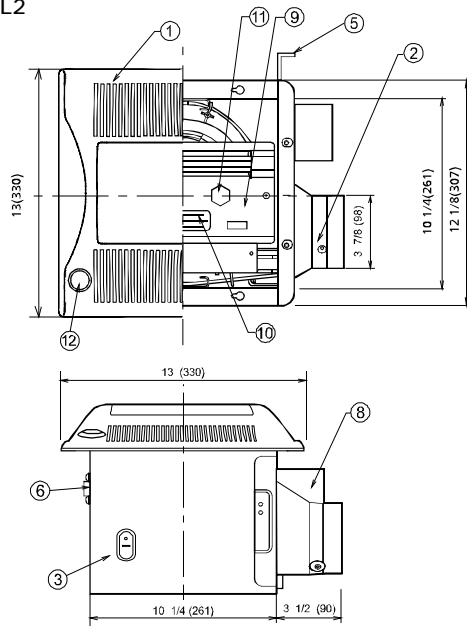

Unit:inches(mm)

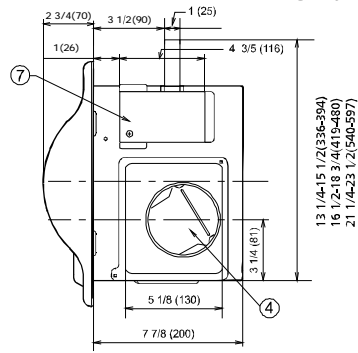

13 1/4-15 1/2(336-394)
16 1/2-18 3/4(419-480)
21 1/4-23 1/2(540-597)

FV-08VKSL2

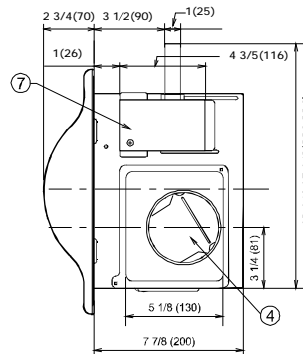
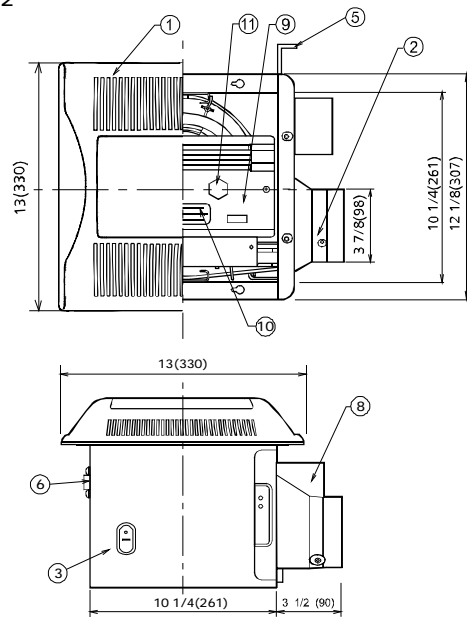

13 1/4-15 1/2(336-394)
16 1/2-18 3/4(419-480)
21 1/4-23 1/2(540-597)

No.	Part name	No.	Part name
1	Grille	7	Junction box cover
2	Adatpor	8	Junction box
3	Fan body	9	Lighting unit
4	Damper	10	Fluorescent lamp
5	Suspension bracket	11	Night lamp
6	Bracket cover	12	Sensor unit

(For 16 inches on center joists, only use suspension bracket I, for 19.2 inches on center joists, only use suspension bracket III. If more than 19.2 inches on center joists, use suspension bracket II & III.)

WIRING DIAGRAM

FV-08VKML2

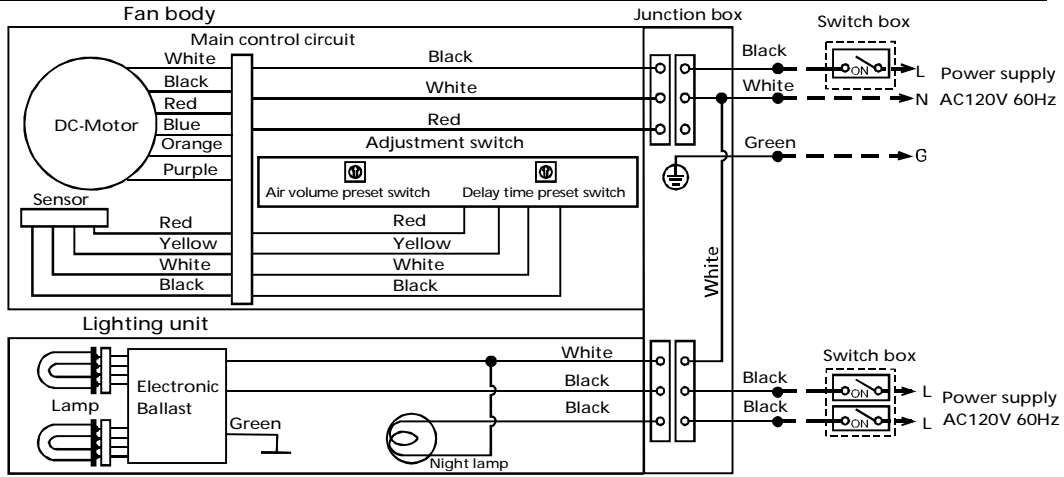

FV-08VKSL2

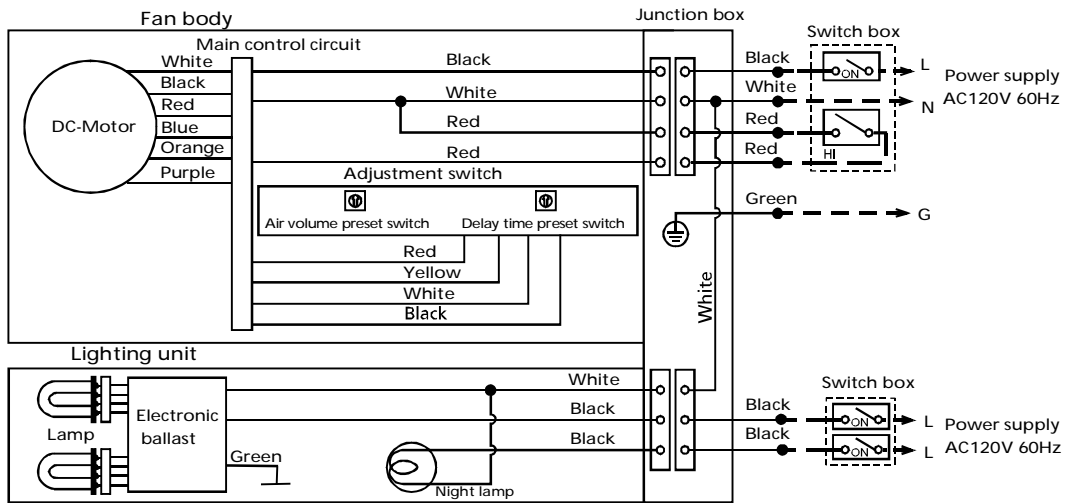

SWITCH INDICATION

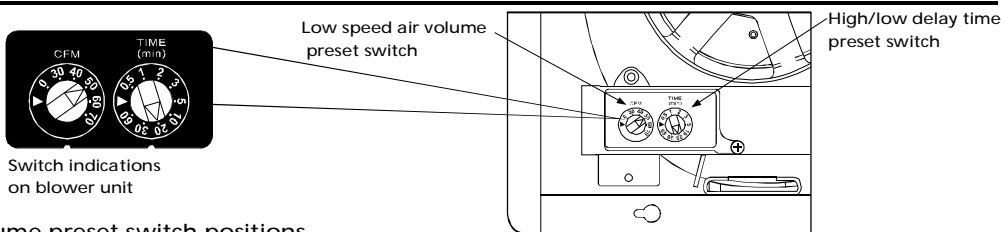

Low speed air-volume preset switch positions

Air Volume [CFM]	0	30	40	50	60	70
------------------	---	----	----	----	----	----

Factory setting: 50 CFM. Position "►": Use for factory test only.

Position "0": Fan stop

High/Low delay time preset switch positions

Delay Time [min]	0.5	1	2	3	5	10	20	30	60
------------------	-----	---	---	---	---	----	----	----	----

Factory setting: 20 minutes. Position "►": Use for factory test only.

OPERATION

■ Detectible range

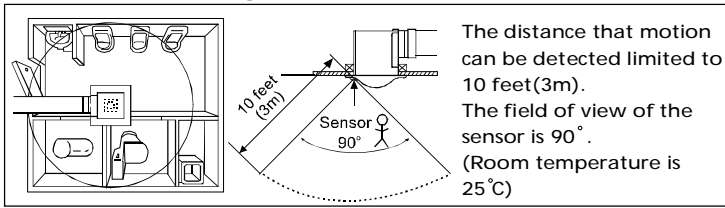

■ Motion sensor

- The low speed is determined by low speed air volume preset switch.
- The delay time is determined by High/Low delay time preset switch.
- Fan operates at high speed for adjustable duration of 0.5 to 60 min. after motion is no longer detected.

Model No.	Human active		Fan active	
	INSIDE	OUTSIDE	At low speed	At high speed
FV-08VKML2	When motion is detected, fan runs at the high speed.	Remains running at high speed until the delay time has passed.	At low speed	At high speed
FV-08VKSL2	When manual wall switch is closed, fan runs at high speed.	When manual wall switch is opened, fan remains running at high speed until the delay time has passed.	At low speed	At high speed

SPECIFICATIONS

■ Specifications

Model No.	Air direction	Voltage (V)	Frequency (Hz)	Duct diameter (inches)	Noise (sones)	Power consumption (W)			Speed (rpm)	Air deliver at 0.1" WG (CFM)	Weight (lb. (kg))
						Fan body	Lighting unit				
							Fluorescent lamp	Night lamp			
FV-08VKML2	Exhaust	120	60	4	0.3	12.6	18X2	4	807	80	16.5 (7.5)
FV-08VKSL2	Exhaust	120	60	4	0.3	12.6	18X2	4	807	80	16.3 (7.4)

HVI Certified performance based on HVI Procedures 915, 916, and 920

■ Reference specifications

Model No.	Air direction	Voltage (V)	Frequency (Hz)	Duct diameter (inches)	Noise (sones)	Power consumption (W)			Speed (rpm)	Air deliver at 0.1" WG (CFM)	Weight (lb. (kg))
						Fan body	Lighting unit				
							Fluorescent lamp	Night lamp			
FV-08VKML2	Exhaust	120	60	4	<0.3	9.6	18X2	4	723	70	16.5 (7.5)
						7.8	18X2	4	675	60	
						6.8	18X2	4	661	50	
						5.9	18X2	4	625	40	
						5.0	18X2	4	587	30	
						1.4 (*)	18X2	4	—	0	
FV-08VKSL2	Exhaust	120	60	4	<0.3	9.6	18X2	4	723	70	16.3 (7.4)
						7.8	18X2	4	675	60	
						6.8	18X2	4	661	50	
						5.9	18X2	4	625	40	
						5.0	18X2	4	587	30	
						1.4 (*)	18X2	4	—	0	

Reference performance based on HVI Procedures 915, 916, and 920.

(*) Standby wattage.

GENERAL SAFETY INFORMATION

1. Do not install this ventilating fan where interior room temperature may exceed 104°F (40°C).
2. Make sure that the electric service supply voltage is AC 120V, 60Hz.
3. Follow all local electrical and safety codes, as well as the National Electrical Code (NEC) and the Occupation Safety and Health Act (OSHA).
4. Always disconnect the power source before working on or near the fan, motor, light fixture or junction box.
5. Protect the power cord from sharp edges, oil, grease, hot surfaces, chemicals or other objects.
6. Do not kink the power cord.
7. Do not install the unit where ducts are configured as shown in Fig.A.
8. Provide suction parts with proper ventilation.
9. This unit is UL listed for use over a bathtub or shower when installed in a GFCI protected branch circuit.
10. This product has a fluorescent lamp that contains mercury. Disposal may be regulated in your community due to environmental considerations. For disposal or recycling information, please contact your local authorities or the Electronics Industries Alliance: <http://www.eiae.org>



Prohibited



Prohibited



Prohibited



Prohibited

Adaptor

Fig.A

CAUTION:

1. For general ventilating use only. Do not use to exhaust hazardous or explosive materials and vapors.
2. Not for use in cooking area. (Fig.B)
3. This product must be properly grounded.

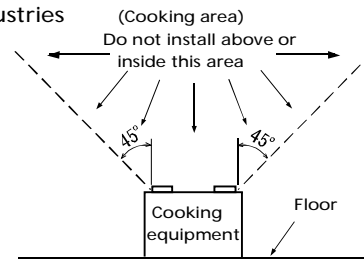

Fig.B

WARNING:

To reduce the risk of fire, electric shock or injury to persons, observe the following:

1. Use this unit only in the manner intended by the manufacturer. If you have any questions, contact to the manufacturer.
2. Installation work and electrical wiring must be done by qualified person(s) in accordance with all applicable codes and standards, including fire-rated construction.
3. Sufficient air is needed for proper combustion and exhausting of gases through the flue (chimney) of fuel burning equipment to prevent back drafting. Follow the heating equipment manufacturer's guideline and safety standards such as those published by the National Fire Protection Association (NFPA), and the American Society for Heating Refrigeration and Air Conditioning Engineers (ASHRAE) and the local code authorities.
4. When cutting or drilling into wall or ceiling, do not damage electrical wiring and other hidden utilities.
5. Ducted fans must always be vented to the outdoors.
6. Do not use this unit with any solid-state control device. Solid state controls may cause harmonic distortion which can cause motor humming noise.
7. Before servicing or cleaning unit, switch power off at service panel and lock the service disconnecting means to prevent power from being switched on accidentally. When the service disconnecting means cannot be locked, securely fasten a prominent warning device, such as a tag, to the service panel.
8. If this unit to be installed over a tub or shower, it must be marked as appropriate for the application and be connected to a GFCI (Ground Fault Circuit Interrupter)-protected branch circuit.
9. Not to be installed in a ceiling thermally insulated to a value greater than R40. (This is required for installation in Canada only.)

INSTALLATION I (JOIST MOUNTING-I)

IMPORTANT:

Remove the tape from damper and adaptor before installation. As shown below:

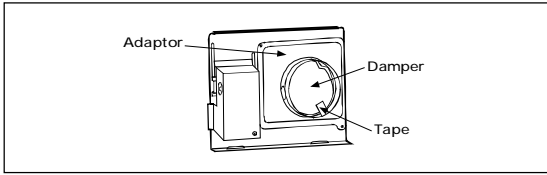

1. Insert the suspension bracket into the fan body and adaptor. (Select the suspension bracket as shown below.)

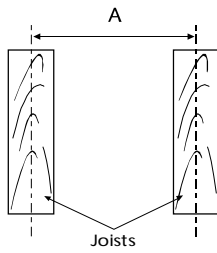

Spacing A on center joists	Insert Suspension bracket
12 inches	Refer to Fig. 1-1
16 inches	Refer to Fig. 1-2
19.2 inches vertical joists	Refer to Fig. 1-3
24 inches	Refer to Fig. 1-4

If spacing A on center joists is 24 inches, connect suspension bracket II and III (C4 mark to C4 mark) as shown below:

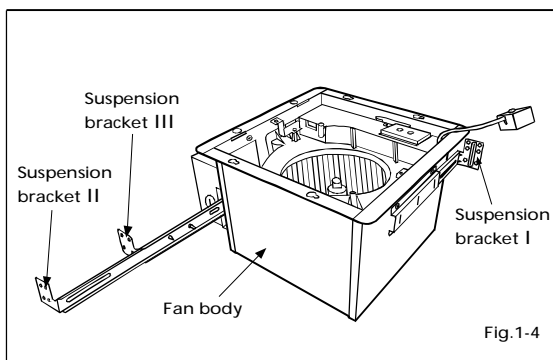
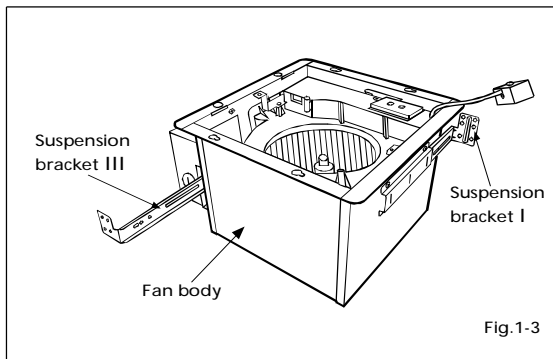
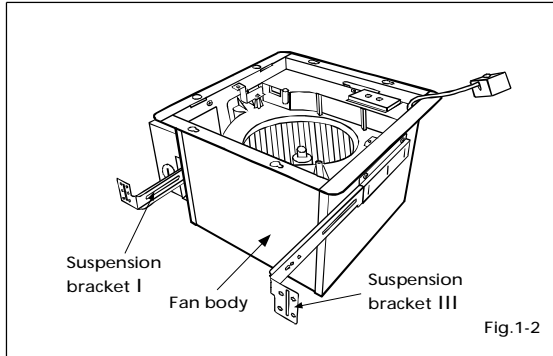
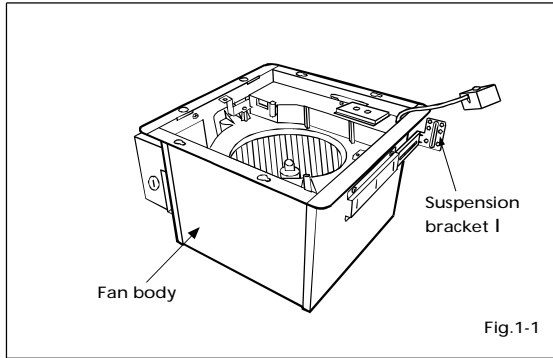
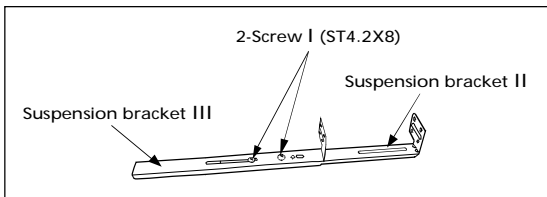

INSTALLATION I (JOIST MOUNTING-I) CONTINUED

2. Install the suspension bracket and the flange of fan body to joists by using long screws (ST4.2X20) (If spacing A between joists is 12 inches, install the flange of fan body according to Fig.2-1, others according to Fig.2-2 to install the product)

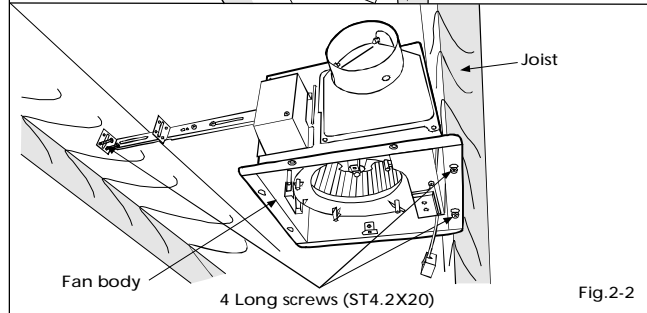
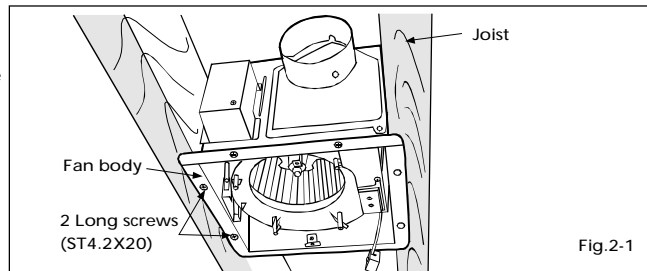

3. Install the suspension bracket to joists by using long screws (ST4.2X20) and secure it to the fan body by using screw II (ST4.2X12) (Fig.3)

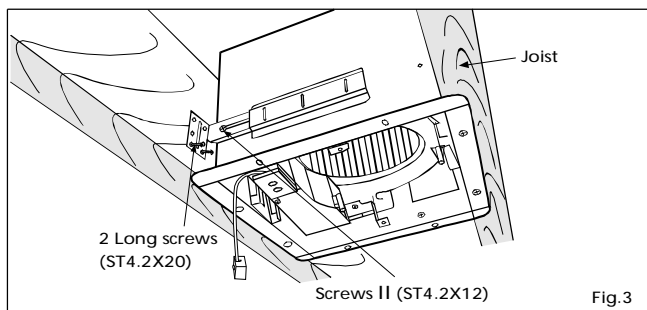

4. Remove junction box cover and secure conduit or stress relief to junction box knock-out hole. (Fig.4)

5. Refer to wiring diagram of page 5. Follow all the local electrical safety codes as well as the National Electrical Code (NEC). Using UL approved wire nuts, connect house power wires to ventilating fan wires: black to black; white to white; green to green; For model FV-08VKSL2 connect the two red wires to the switch for the speed control. Replace the junction box cover. (Fig.4)

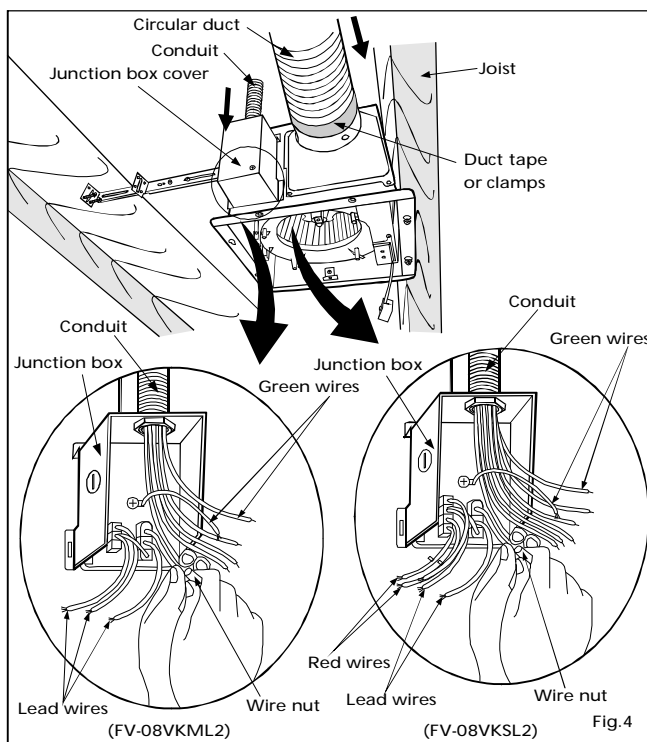

CAUTION:
Mount junction box cover carefully so that lead wires are not pinched.

6. Install a circular duct and secure it with duct tape or clamps.

INSTALLATION I (JOIST MOUNTING-I) CONTINUED

7. Finish ceiling work. Ceiling hole should be aligned with the edge of the flange. (Fig.5)

8. Insert the plug connector II into the receptacle II, and secure the lighting unit to the fan body with 1 screw III (ST4.2X16) and 2 machine screws (M4X8). (Fig.5)

CAUTION:

The machine screws must be tight fit.

9. Insert the fluorescent lamps and secure the night lamp into the lighting unit. (Fig.5)

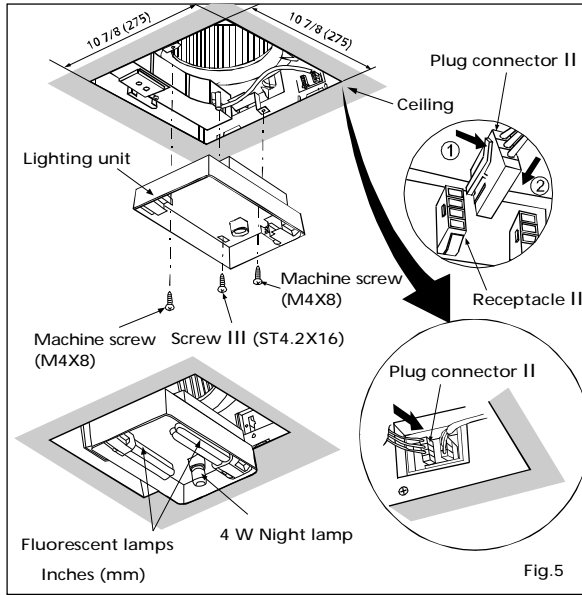

10. Insert mounting spring into the slot as shown and adjust high/low delay time preset switch and low speed air volume preset switch. Refer to switch indication on page 5 (FV-08VKML2) (Fig.6-1)

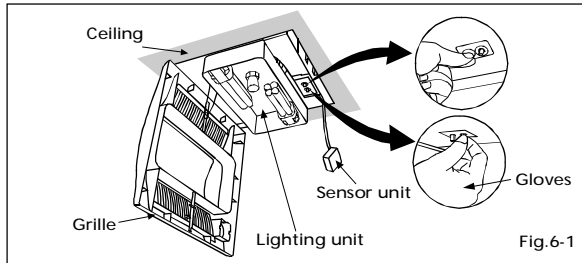

11. Insert the sensor unit into the housing of the grille and insert other mounting spring into the slot as shown and mount grille to fan body (FV-08VKML2) (Fig.6-2, Fig.6-3)

CAUTION:

Mount grille carefully so that lead wire of sensor unit is not pinched.

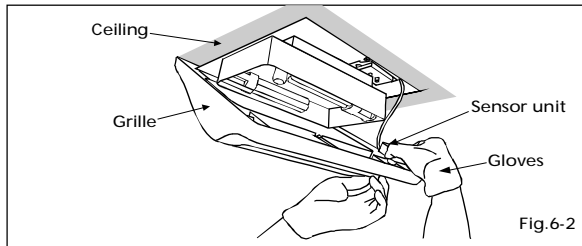

12. Insert mounting springs into the slots as shown and mount grille to fan body. (FV-08VKSL2) (Fig.7)

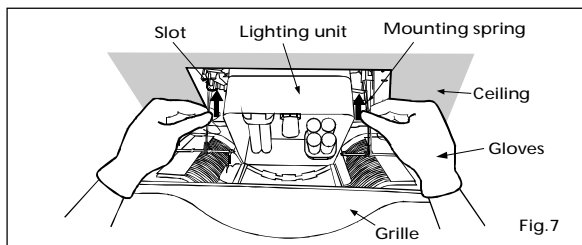
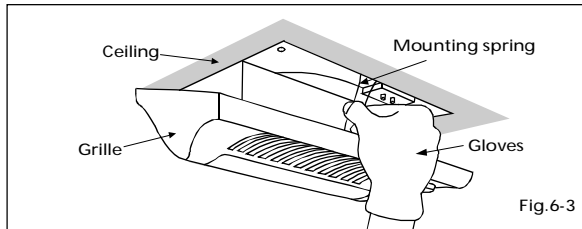

INSTALLATION II (JOIST MOUNTING-II)

(When spacing the fan body flange below the drywall or resilient channel)

1. Remove the machine screw by using screw driver, disconnect plug connector from receptacle and remove adaptor from fan body before installation, (Fig.8)

2. Insert the suspension bracket into the adaptor and secure it to joists by using long screws (ST4.2X20) (Fig.9)
Keep the distance B (1/2 inch, 12.7mm or 5/8 inch, 15.9mm) for the thickness of ceiling board.

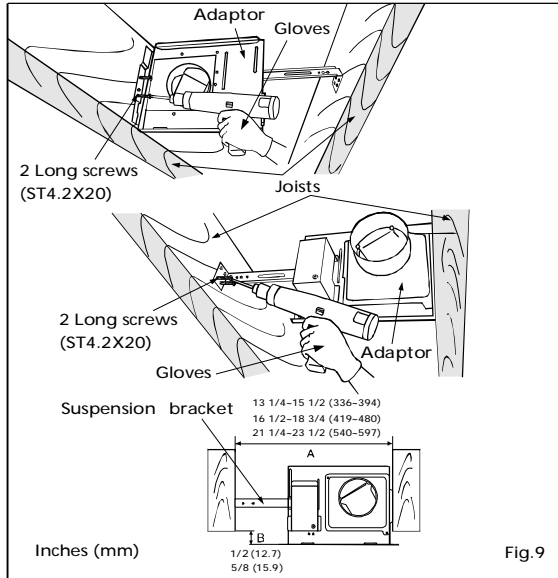
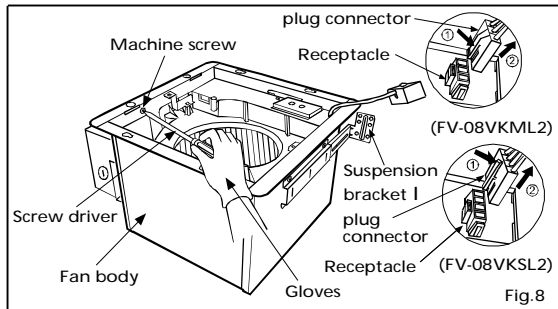

If spacing A between joists is 21 1/4 to 23 1/2 inches (540 to 597mm), connect suspension bracket II and III (C4 mark to C4 mark) according to page. 8 Select the suspension bracket according to spacing A as shown below:

Spacing A between Joists inches (mm)	13 1/4-15 1/2 (336-394)	16 1/2-18 3/4 (419-480)	21 1/4-23 1/2 (540-597)
Suspension bracket	Suspension bracket I	Suspension bracket III	Suspension bracket II & III

3. Follow steps 4 to 6 of the installation I (page 9) to complete the duct work and wiring.

4. Insert the suspension bracket into fan body (referring to step 1 of installation I, page 8)

5. Insert the fan body into joists. (Fig.10)

IMPORTANT:

Make sure that adaptor claws are properly inserted into fan body slots.

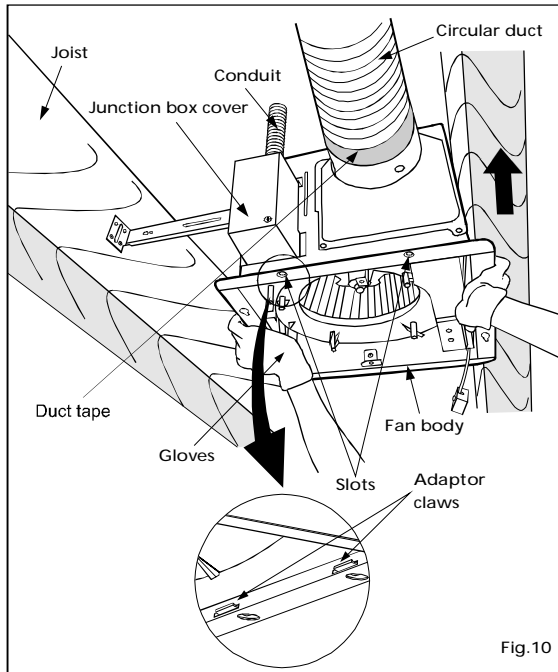

INSTALLATION II (JOIST MOUNTING-II) CONTINUED

6. Secure the fan body to adaptor by using machine screw and plug connector to receptacle (Fig.11)

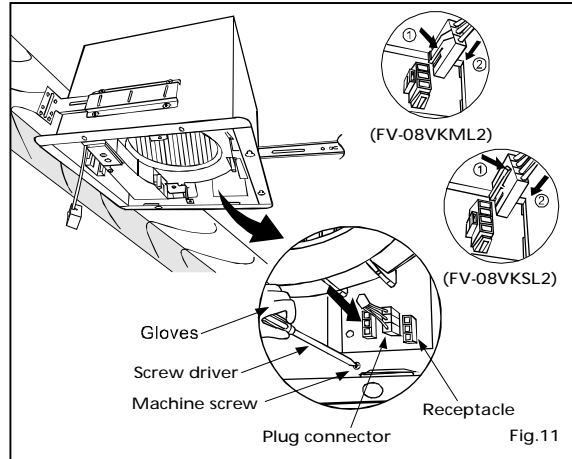

7. Secure the suspension bracket to joists by using long screws (ST4.2X20) and secure it to fan body by using screw II (ST4.2X12) in vertical direction (Fig.12)

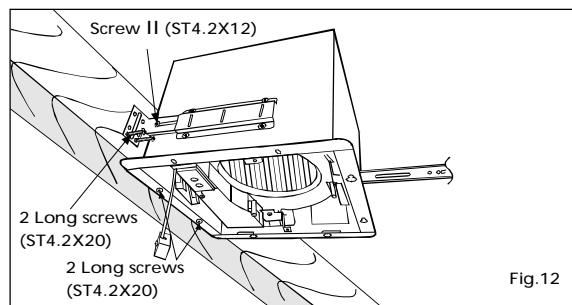

8. Follow steps 7 to 12 of Installation I (page 10) to complete the installation work.

INSTALLATION III (I-JOIST MOUNTING)

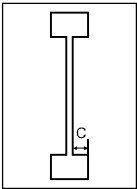

4 kinds of I-joist inches (mm)		hole mark
C	9/16 (14.3)	C1
	11/16 (17.5)	C2
	31/32 (24.6)	C3
	1 17/32 (38.9)	C4

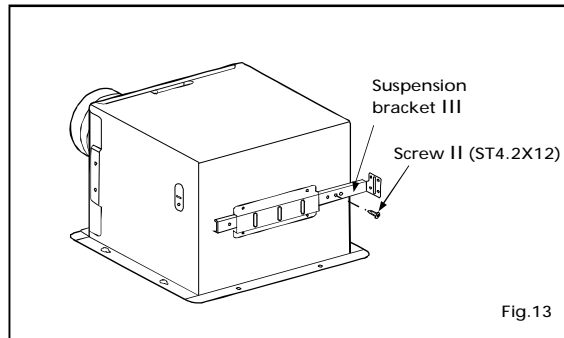
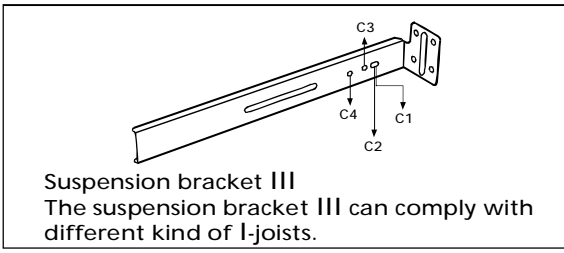

1. Before installation, secure the lighting unit to fan body (referring to Fig.5 of page 10).
2. Connect the suspension bracket III to fan body. (Fig.13) (Select the hole by checking I-joist size and fix the screw to the frame hole.)
3. Connect the fan body to the I-joist. (Fig.14)
4. Follow steps 4 to 12 of installation I (page 9, page 10) to complete the installation work.

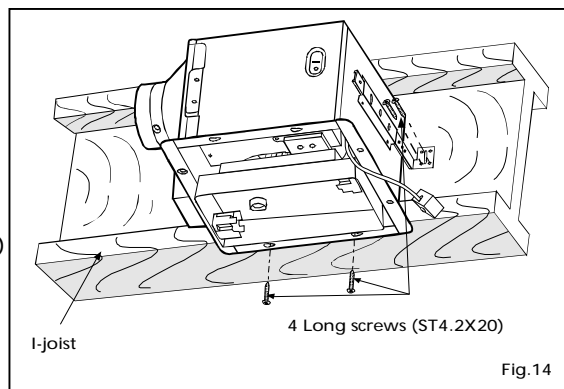

INSTALLATION IV (SUSPENDED BETWEEN JOIST MOUNTING)

1. Before installation, secure the lighting unit to fan body (referring to Fig.5 of page 10).

2. Insert the suspension bracket into bracket cover of adaptor side and the back of the fan body. (Fig.15-1,15-2) (select the suspension bracket according to spacing A as shown below.)

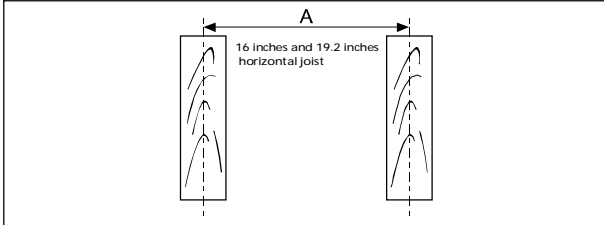

3. Insert the fan body between joists. Make sure the fan body is level and square (perpendicular) with the joists. (Fig.16)

If installing with fan body flange below drywall, keep the distance B (1/2 inch, 12.7mm or 5/8 inch, 15.9mm) for the thickness of ceiling board.

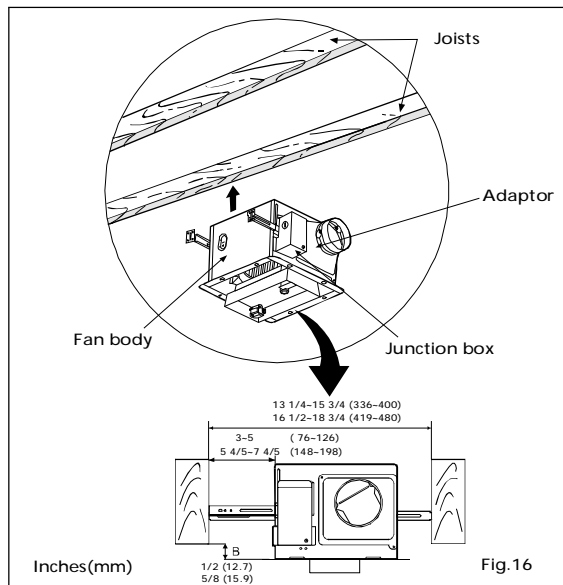
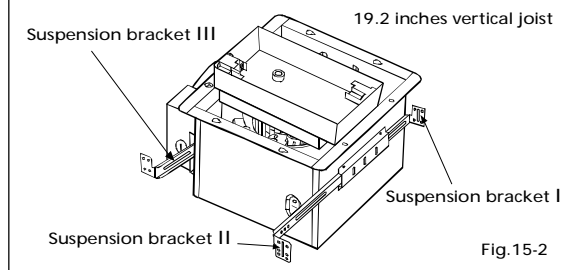
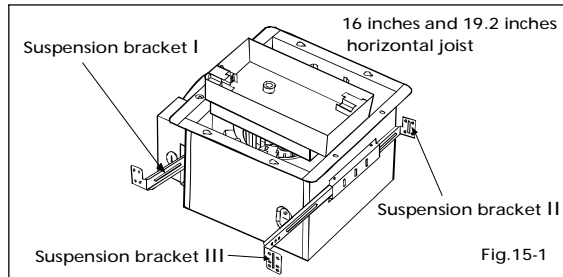

4. Secure the suspension bracket to joists by using long screws (ST4.2X20) (Fig.17, Fig.18)

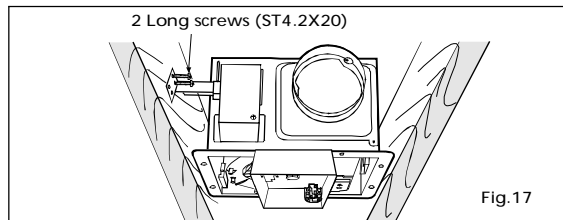

5. Secure the suspension bracket to fan body by using screw II (ST4.2X12) (Fig.18)

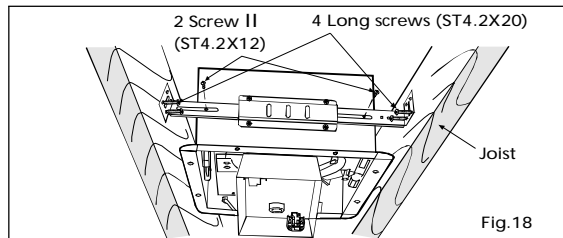

6. Follow steps 4 to 12 of installation I (page 9, page 10) to complete the installation work.

INSTALLATION V (WOODEN HEADER)

1. Before installation, secure the lighting unit to fan body (referring to Fig.5 of page 10).
2. Install header between joists by using nails or screws.
3. Install the fan body and secure it by using long screws (ST4.2X20) (Fig.19, Fig.20)
4. Follow steps 4 to 12 of installation I (page 9, page 10) to complete the installation work.

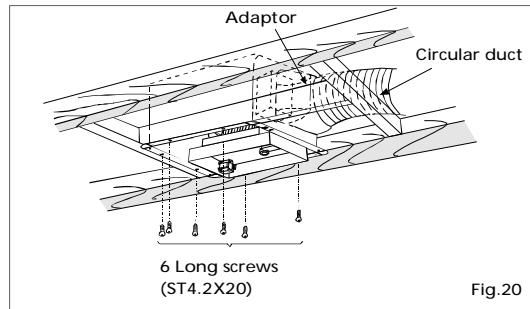
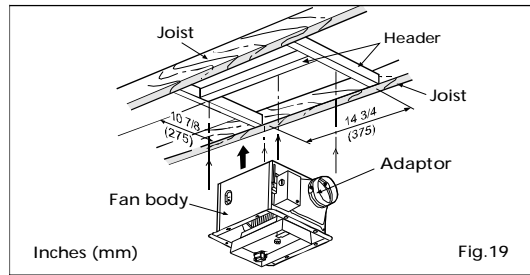

INSTALLATION VI (IN EXISTING CONSTRUCTION)

1. Installation in existing construction.
Installing the fan body in an existing building requires an accessible area (attic or crawl space) above the planned installation location or existing ducting and wiring.
 - (1) To install the fan body, follow the procedures described in Installation II. Take the following precautions before installation.

CAUTION:

Check area above planned installation location to be sure that:

1. Duct work can be done and that area is sufficient for proper ventilation.
 2. Wiring can be run to planning location.
 3. No wiring or other obstructions shall interfere with installation.
2. Installation from accessible area above fan location.
 - (1) Inspect duct work and wiring before proceeding with installation.
 - (2) Remove ceiling section.
 - (3) Install fan body from above with fan body flange flush to drywall ceiling.

MAINTENANCE I (CLEANING)

WARNING:

Disconnect power source before working on unit. Routine maintenance must be done every year.

CAUTION:

1. Never use gasoline, benzene, thinner or any other such chemicals for cleaning the ventilating fan.
2. Do not allow water to get into the motor.
3. Do not soak resin parts in water over 140°F (60°C).

1. Remove grille pull down one mounting spring. Remove sensor unit then pull down the other mounting spring. (Squeeze mounting spring and pull down carefully.) (Fig.21-1,21-2)
2. Wash and clean grille. (Use non-abrasive kitchen detergent, wipe dry with new cloth.) (Fig.22)
3. The grille should be dry after cleaning. (Fig.23)
4. Remove dust and dirt from fan body using a vacuum cleaner. (Fig.24)
5. Using a cloth dampened with kitchen detergent, remove any dirt from fan body. Wipe dry with new cloth. (Fig.25)
6. Replace grille.

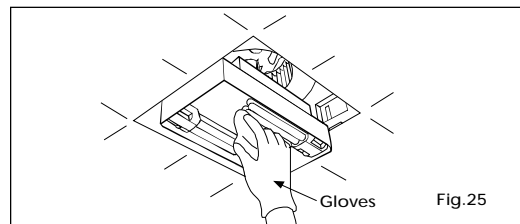
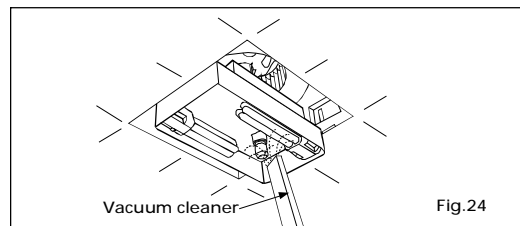
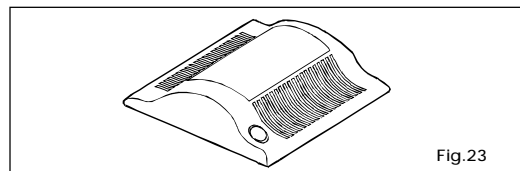
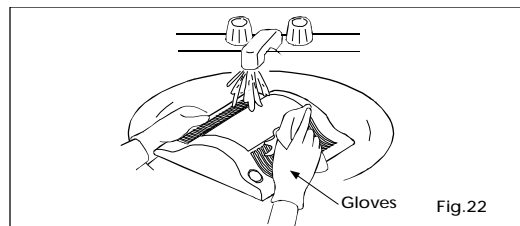
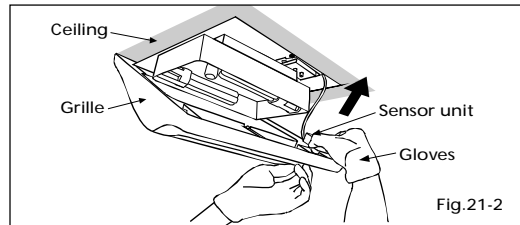
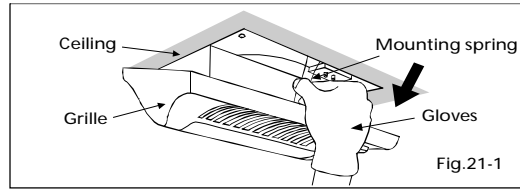

MAINTENANCE II (REPLACEMENT OF LAMP)

WARNING:

1. Disconnect power source before working on unit.
2. The lamp's glass is fragile. Please handle with care. To remove lamp, grasp at base and move back and force to loosen. Do not pull hard on the lamp or you may break the glass.
3. 4W night lamp has threaded base. Remove by turning counterclockwise.
4. Be sure to remove the night lamp before remove fluorescent lamps.

MAINTENANCE II (REPLACEMENT OF LAMP) CONTINUED

1. Remove grille. (Squeeze mounting spring and pull down) (Fig.21-1,21-2 of page 15)

2. Remove the 4 W night lamp. (Fig.26)

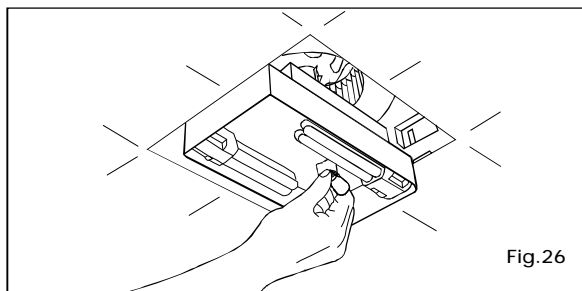

Fig.26

3. Change the fluorescent lamps (Panasonic FDS 18E27/4, 18W or FDS18E35/4, 18W or FDS18E42/4, 18W) or the 4W night lamp, connect the plug connector II and replace the grille. (Fig.27)

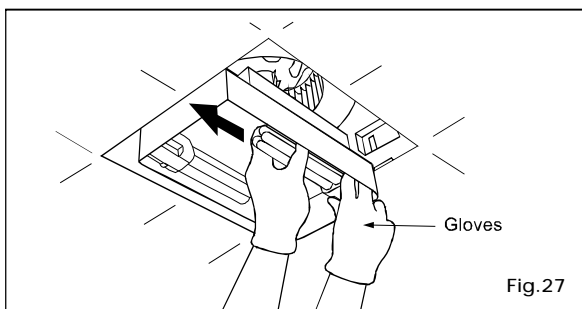

Fig.27

PRACTICAL GUIDE TO INSTALLATION

Proper insulate the area around the fan to minimize building heat loss and gain. (Fig. 28)

Loose fill or batt insulation can be placed directly over the fan housing in the attic. Panasonic fans and fan/light combination units do not create excessive heat that is a common problem with recessed light fixtures or some competitors' fan/light combinations. Our efficient, cool-running motors and our fluorescent lamps do not create enough ambient heat to be subjected to these limitations.

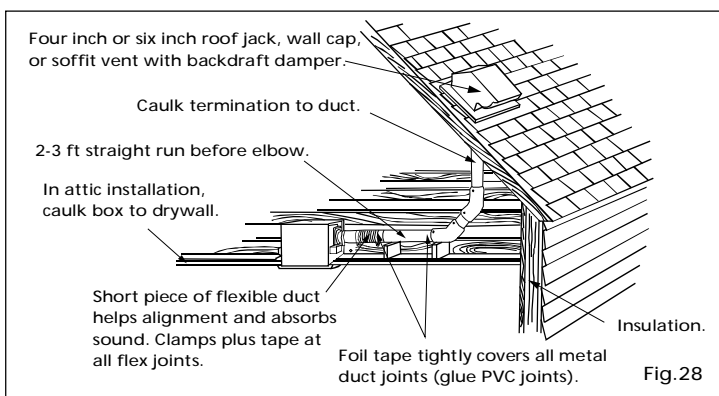

Fig.28

PRODUCT SERVICE

Warning Concerning Removal of Covers.

The unit should be serviced by qualified technicians only. No service information is provided for customers. Your product is designed and manufactured to ensure a minimum of maintenance. However, should your unit ever require service, a nationwide system of factory service centers and AUTHORIZED INDEPENDENT SERVICE CENTERS is maintained to support your product's warranty. (In the U.S.A., Call 1-866-292-7292 to Customer call Center.)

PANASONIC CONSUMER ELECTRONICS COMPANY

Division of Panasonic Corporation of North America,
One Panasonic Way, Secaucus, NJ 07094
www.panasonic.com

PANASONIC CANADA INC.

5770 Ambler Drive, Mississauga, ON L4W 2T3
www.panasonic.ca