

## Ventilating Fan **INSTALLATION INSTRUCTIONS**

Model No. **FV-11VH2**  
**FV-11VHL2**

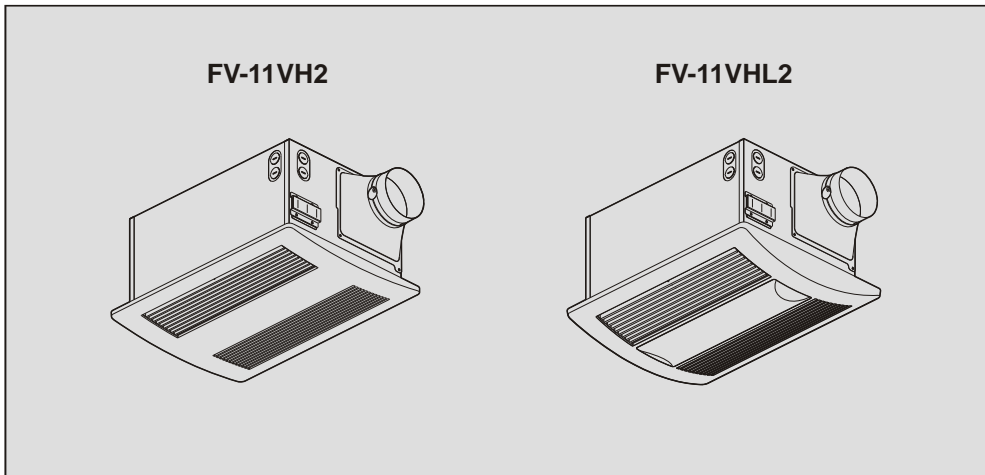

### **READ AND SAVE THESE INSTRUCTIONS.**

Thank you very much for having purchased our Ventilating Fan.  
Please read these instructions carefully before attempting to install, operate or service the Panasonic Ventilating Fan. Failure to comply with instructions could result in personal injury and/or property damage. Please retain this booklet for future reference.

### **Table of Contents**



|   |            |
|---|------------|
| Unpacking .....                                       | 2          |
| Supplied Accessories .....                            | 2          |
| Description .....                                     | 2          |
| Dimensions .....                                      | 3          |
| Specifications .....                                  | 4          |
| General Safety Information .....                      | 4-5        |
| Wiring Diagram .....                                  | 5          |
| Installation I ( Joist Mounting-I ) .....             | 6-7        |
| Installation II ( Between Joist Mounting ) .....      | 8-9        |
| Installation III ( Wooden Header Installation ) ..... | 9          |
| Maintenance I ( Cleaning ) .....                      | 10         |
| Maintenance II ( Replacement of lamp ) .....          | 11         |
| Practical Guide to Installation .....                 | back cover |
| Product Service .....                                 | back cover |

## UNPACKING



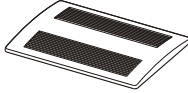
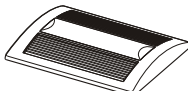
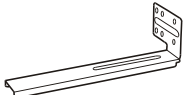
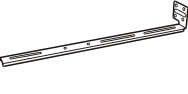

Unpack and carefully remove unit from carton.  
Refer to the Supplied Accessories list to verify that all parts are present.

## SUPPLIED ACCESSORIES

FV-11VH2  
FV-11VHL2

| Part name              | Appearance   | Quantity |
|------------------------|--|----------|
| Grille                 | <br>FV-11VH2  | 1        |
|                        | <br>FV-11VHL2 |          |
| Suspension bracket I   |               | 1        |
| Suspension bracket II  |             | 1        |
| Suspension bracket III |             | 1        |
| Screw I (ST4.2X8)      |             | 2        |

\* Parts only for FV-11VHL2.

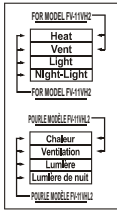
| Part name                 | Appearance   | Quantity |
|---------------------------|--|----------|
| Screw II (ST4.2X12)       |    | 2        |
| Long screw (ST4.2X20)     |    | 6        |
| 18W<br>* Fluorescent lamp |    | 2        |
| 4W<br>* Night lamp        |  | 1        |
| Switch labels             |  | 1        |

## DESCRIPTION

The Panasonic ceiling mount ventilating fans uses a sirocco fan driven by a capacitor motor. The motor is designed to have an extended service life with reduced energy consumption. It also incorporates a thermal cut-off for safety. The grille covering the main body is a spring-loaded, quick-release type. A damper for preventing counterflow is provided. The blower uses a high-capacity sirocco fan developed to reduce the noise level.

The heater for this unit is a 1400 W sheathed heater. A thermostat and thermal cut-off switch have been added for safety in case of an abnormal temperature rise in the heater.

The lighting unit is an energy-saving, lighting device which uses two 18 W fluorescent lamps and produces almost the same illumination as a standard 100 W incandescent lamp (FV-11VHL2).

# DIMENSIONS

FV-11VH2

Unit: inches (mm)

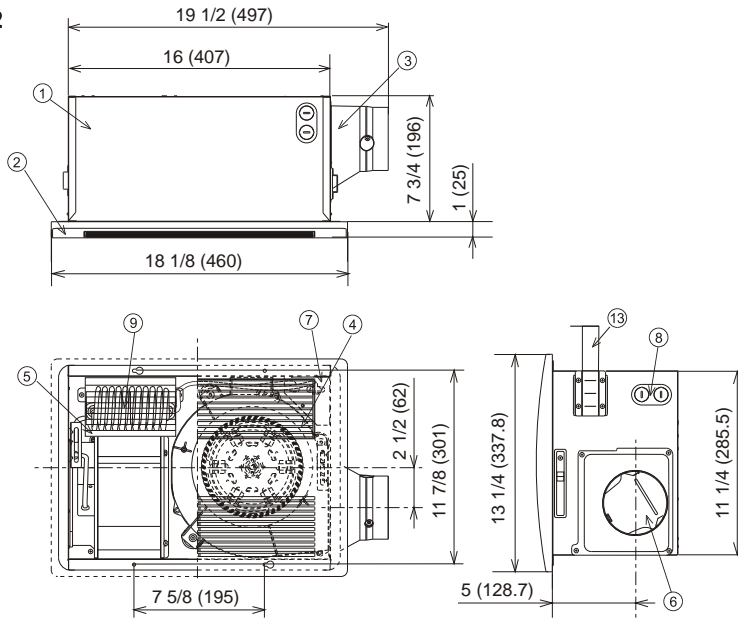

FV-11VHL2

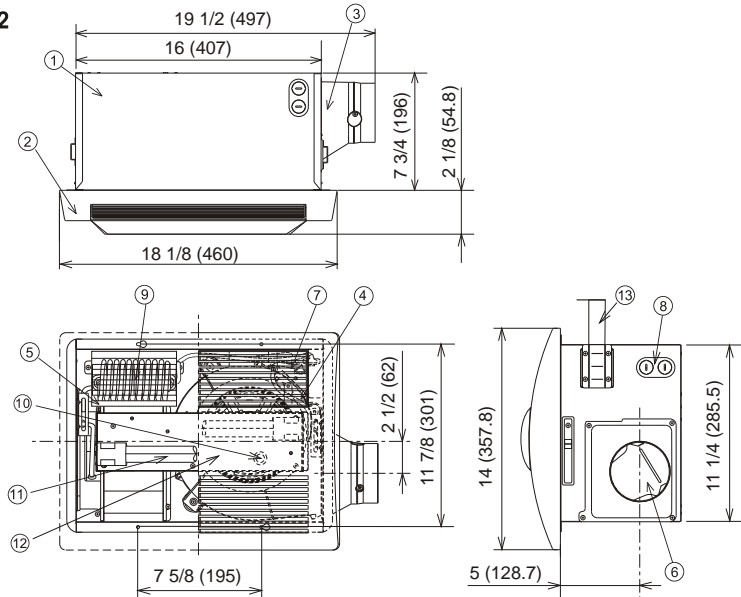

| No. | Part name        | No. | Part name          |
|-----|------------------|-----|--------------------|
| ①   | Fan body         | ⑧   | Knock out holes    |
| ②   | Grille           | ⑨   | Heater             |
| ③   | Adaptor          | ⑩   | Night lamp         |
| ④   | Ventilating unit | ⑪   | Fluorescent lamp   |
| ⑤   | Heating unit     | ⑫   | Lighting unit      |
| ⑥   | Damper           | ⑬   | Suspension bracket |
| ⑦   | Junction box     |     |                    |

# SPECIFICATIONS

| Model No. | Air direction         | V   | Hz | Power consumption (W) |      |                  |            | Speed (rpm) |      | Air deliver          | Noise       | Weight lb. (kg) |
|-----------|-----------------------|-----|----|-----------------------|------|------------------|------------|-------------|------|----------------------|-------------|-----------------|
|           |                       |     |    | Heat                  | Vent | Fluorescent lamp | Night lamp | Heat        | Vent | Vent (0.1" WG) (cfm) | Vent (sone) |                 |
| FV-11VH2  | Exhaust & Circulation | 120 | 60 | 1425                  | 29.5 | —                | —          | 1540        | 650  | 110                  | 0.6         | 15.6 (7.1)      |
| FV-11VHL2 |                       |     |    |                       |      | 36               | 4          |             | 720  |                      | 0.7         | 17.8 (8.1)      |

Specifications of Vent are based on HVI standard.

# GENERAL SAFETY INFORMATION

- Do not install this ventilating fan where air temperature may exceed 40°C (104°F).
- Make sure that the electric service supply voltage is AC 120V, 60Hz.
- Follow all local electrical and safety codes, as well as the National Electrical Code (NEC) and the Occupation Safety and Health Act (OSHA).
- Always disconnect the power source before working on or near the fan, motor, light fixture or junction box.
- Protect the power cord from sharp edges, oil, grease, hot surfaces, chemicals or other objects.
- Do not kink the power cord.
- Do not install the unit where ducts are configured as shown in Fig. A.
- Make sure that all duct work is properly vented.
- DO NOT INSTALL THIS UNIT OVER A BATHTUB OR SHOWER ENCLOSURE.
- \* 10. This product (FV-11VHL2) has a fluorescent lamp that contains mercury. Disposal may be regulated in your community due to environmental considerations. For disposal or recycling information, please contact your local authorities or the Electronics Industries Alliance: <http://www.eiae.org>



Fig. A

\* Only for FV-11VHL2.

### CAUTION:

- For general ventilating use only. Do not use to exhaust hazardous or explosive materials and vapors.
- Not for use in cooking area. (Fig .B)
- This product must be properly grounded.

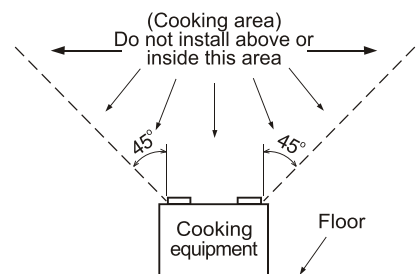

Fig. B

# GENERAL SAFETY INFORMATION CONTINUED

## WARNING:

To reduce the risk of fire, electric shock or injury to persons, observe the following:

- A. Use this unit only in the manner intended by the manufacturer. If you have any questions, please contact the manufacturer.
- B. Installation work and electrical wiring must be done by qualified person(s) in accordance with all applicable codes and standards, including fire-rated construction. Neither unauthorized modification, repair nor disassembly is allowed.
- C. Sufficient air is needed for proper combustion and exhausting of gases through the flue (chimney) of fuel burning equipment to prevent backdrafting. Follow the heating equipment manufacturer's guideline and safety standards such as those published by the National Fire Protection Association (NFPA), and the American Society for Heating Refrigeration and Air Conditioning Engineers (ASHRAE) and the local code authorities.
- D. When cutting or drilling into wall or ceiling, do not damage electrical wiring and other hidden utilities.
- E. Ducted fans must always be vented to the outdoors.
- F. Solid state controls may cause harmonic distortion which can cause motor humming noise. To reduce the risk of fire or electric shock, do not use this unit with any solid-state control device.
- G. Before servicing or cleaning unit, switch power off at service panel and lock panel cabinet to prevent power from being switched on accidentally. If the panel cabinet cannot be locked, securely fasten a clearly visible warning label to the service panel.
- H. Never place a switch where it can be reached from a tub or shower.
- I. Not to be installed in a ceiling thermally insulated to a value greater than R40. (This is required for installation in Canada only.)
- J. Use only on 20 ampere branch circuit.

# WIRING DIAGRAM

**FV-11VH2**

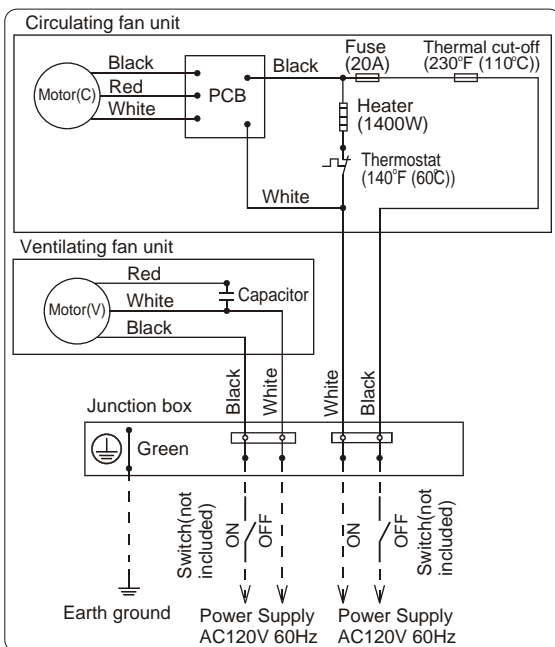

**FV-11VHL2**

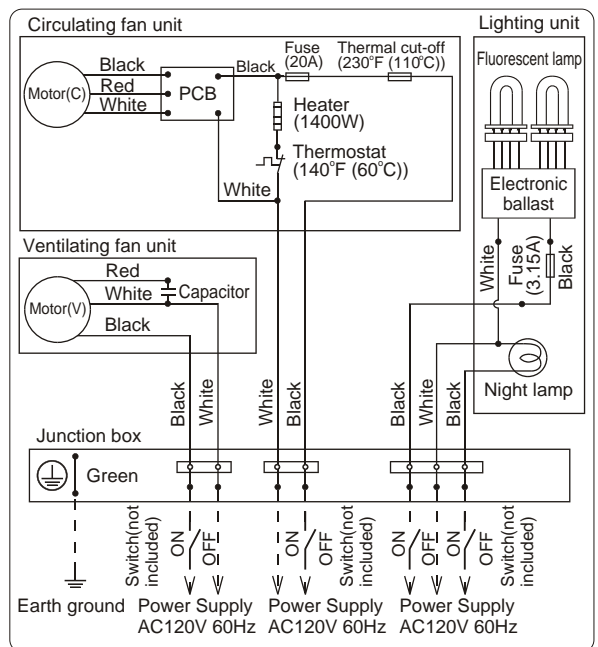

# INSTALLATION I (JOIST MOUNTING-I)

Illustrations in this manual common use the image of FV-11VHL2, and ★ mark for FV-11VHL2 only, others are same for FV-11VH2.

1. Before installation, remove warning lable and the tape that is securing the adapter and the damper. (Fig.1)

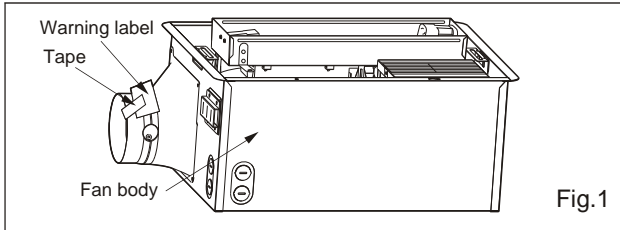

2. Insert the suspension bracket into the fan body. (Select the suspension bracket as shown below.)

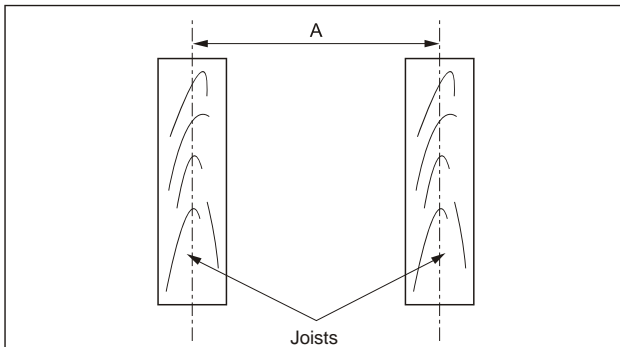

| Spacing A on center Joists                  | Insert Suspension bracket |
|---|---------------------------|
| 16 inches and 19.2 inches horizontal joists | Refer to Fig. 2-1         |
| 19.2 inches vertical joists                 | Refer to Fig. 2-2         |
| 24 inches                                   | Refer to Fig. 2-3         |

If spacing A on center joists is 24 inches, connect suspension bracket II and III (C4 mark to C4 mark) as shown below :

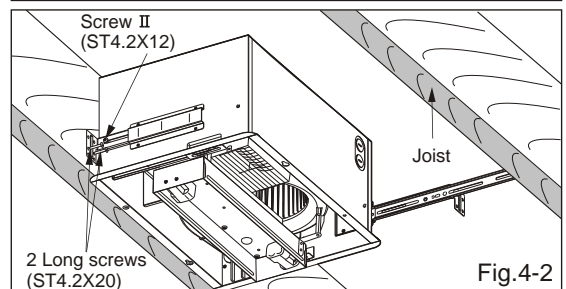
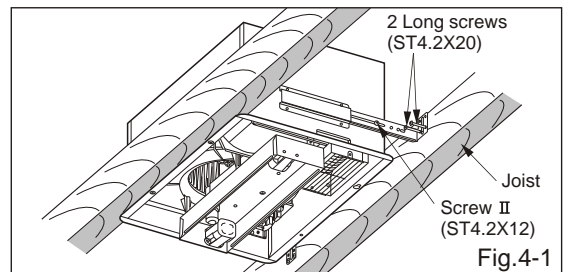
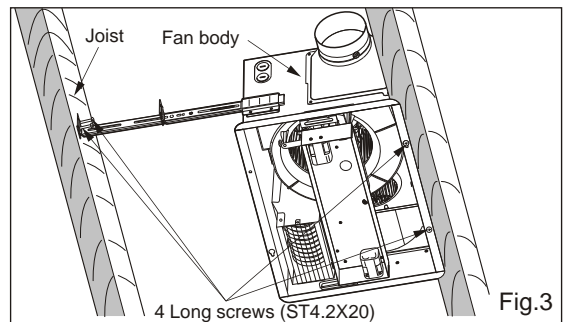
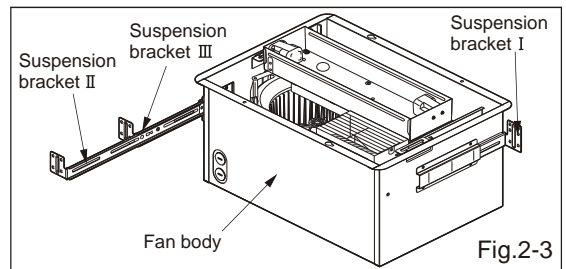
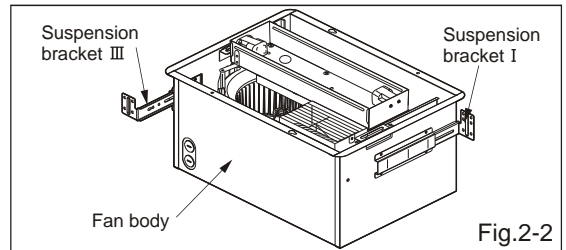
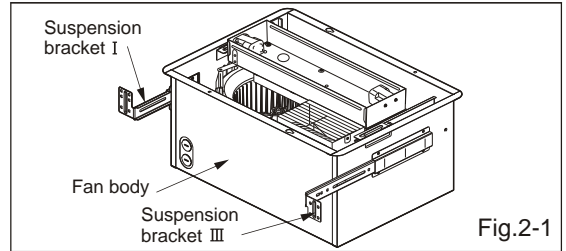
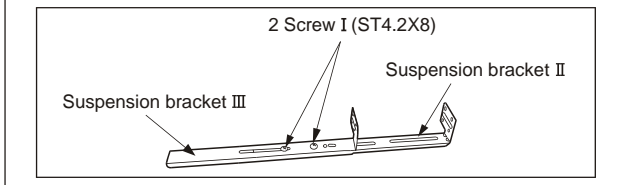

3. Install the suspension bracket and the flange of fan body to joists by using long screws (ST4.2X20). (Fig.3)

4. Install the suspension bracket to joists by using long screws (ST4.2X20) and secure it to the fan body by using screw II (ST4.2X12). 16 inches and 19.2 inches horizontal joists refer to Fig.4-1, 19.2 inches vertical joists and 24 inches refer to Fig.4-2.

# INSTALLATION I (JOIST MOUNTING-I) CONTINUED

- Remove the lighting cord out from hook (FV-11VHL2), then remove junction box plate and secure conduit or stress relief to wiring box knock-out hole.(Fig.5)
- Refer to wiring diagram (Page.5)  
Follow all the local electrical safety codes. As well as the National Electrical Code (NEC).  
Using UL approved wire nuts, connect house power wires to ventilating fan wires (Fig.6):  
Black to black; white to white; green to green.  
Make sure all connections are fastened firmly after wiring is finished.  
Replace the junction box plate, and then replace lighting cord to hook. (Fig.5)

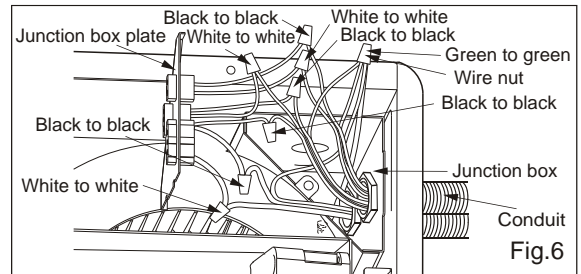
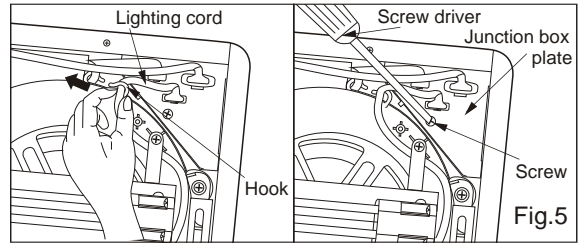

## CAUTION:

Mount junction box plate carefully so that lead wires are not pinched.

## WARNING

- Disconnect power source before working on unit.
- The lamp's glass is fragile. Please handle with care. To remove flourescent lamp, grasp at base and move back and forth to loosen. Do not pull hard on the lamp or you may break the glass.
- For heater, AWG 14 or more must be used when wiring (11.9A).
- When making wiring connections take care to prevent excessive slack in the wiring since a large of current is drawn through the heater electrical wire.
- Connect the switch to the live (black color) side.

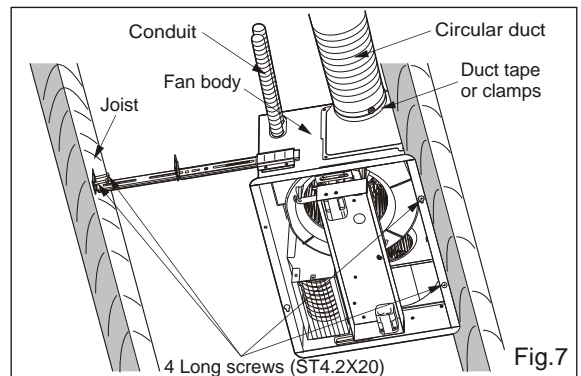

- Install the circular duct (4 inches) to the adaptor and secure it with duct tape or clamps. (Fig.7)
- Finish ceiling work. Ceiling hole should be aligned with the edge of the flange. (Fig.8)

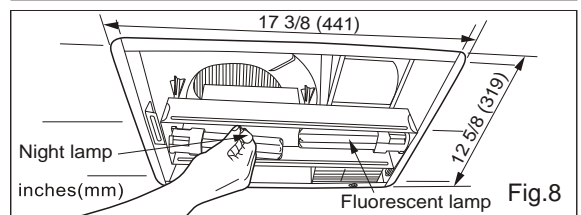

- Install the flourescent lamps and then install the night lamp. (Fig.8)

- Insert mounting springs into slots as shown and mount grille to fan body. (Fig.9)

Note:Do not mount grille and springs conversely. If the grille is mounted in the opposite direction, the grille can not be fitted to the ceiling, so then reverse the grille position and try to mount again.

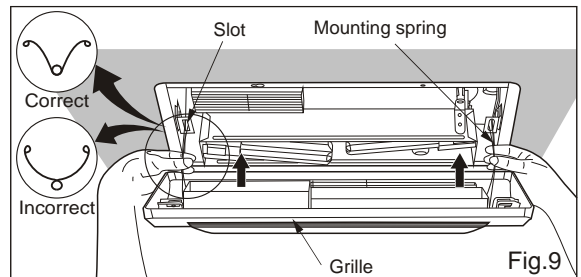

[Optional]

Attach the given switch labels (in accessories) on the wall switch (not included) as shown in the diagram for clearer indication. (Fig.10)

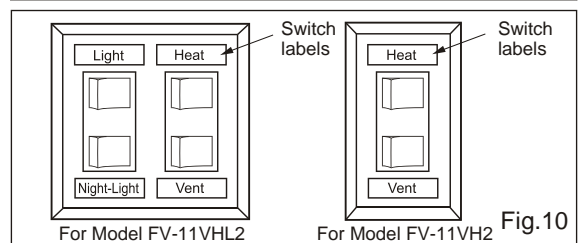

# INSTALLATION II (BETWEEN JOIST MOUNTING)

Illustrations in this manual common use the image of FV-11VHL2.

1. Before installation, remove warning lable and the tape that is securing the adaptor and the damper. (Fig.1)
2. Insert the suspension bracket into bracket cover of adaptor side and the back of the fan body. (Fig.11)  
(Select the suspension bracket according to spacing A as shown below.)

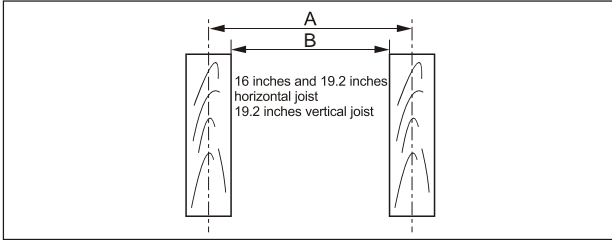

Unit: inches (mm)

| Spacing A on center joists    | B                         |
|-------------------------------|---------------------------|
| 16 inches                     | 13 1/4 ~ 15 1/2 (336~394) |
| 19.2 inches horizontal joists | 14 3/4 ~ 16 3/4 (374~425) |
| 19.2 inches vertical joists   | 16 1/2 ~ 18 3/4 (419~476) |

3. Insert the fan body between joists.  
Make sure the fan body is level and square (perpendicular) with the joists. (Fig.12)

**CAUTION:**

Keep the distance C (1/2 inch, 12.7 mm) for the thickness of ceiling board.

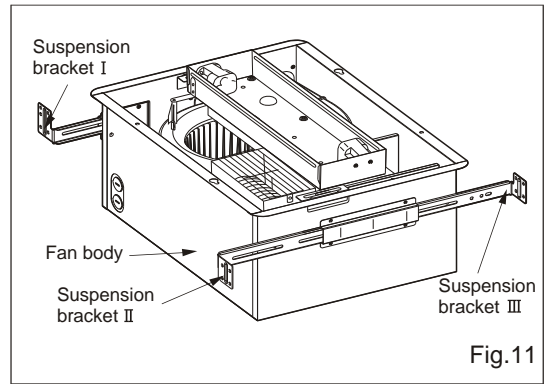

Fig.11

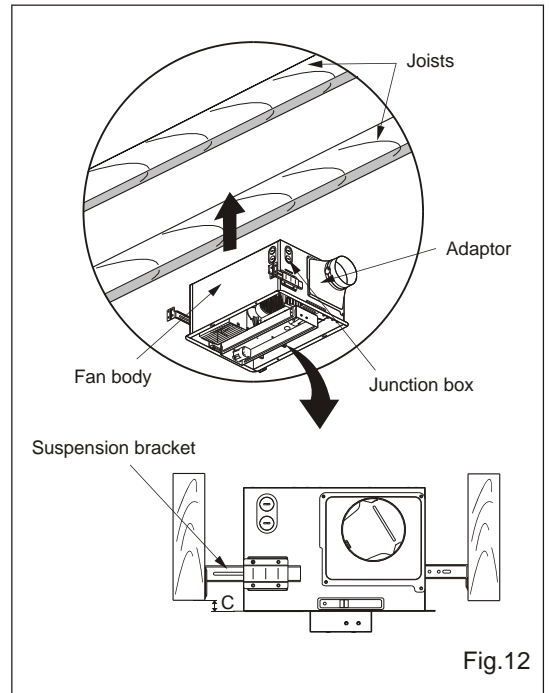
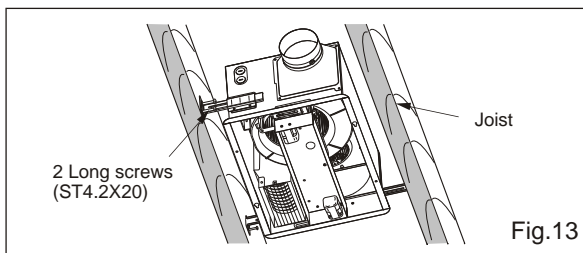

Fig.12



## INSTALLATION II (BETWEEN JOIST MOUNTING) CONTINUED

- Secure the suspension bracket to joists by using long screws (ST4.2X20). (Fig.13, Fig.14)



- Secure the suspension bracket to fan body by using screw II (ST4.2X12). (Fig.14)

- Follow step 5 of installation I (page 7) to complete the installation work.

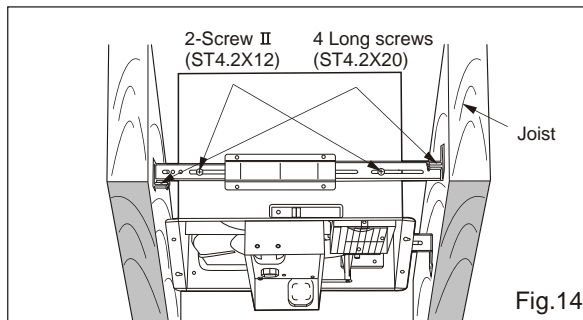

## INSTALLATION III (WOODEN HEADER INSTALLATION)

- Before installation, remove warning lable and the tape that is securing the adaptor and the damper. (Fig.1)
- Install header between ceiling joists using nails or screws.
- Install the fan body to the header (thickness:1.5 inch or more) with long screws. Reinforce the installation hardware as needed to prevent the fan body from dropping. (Fig.15, Fig.16)

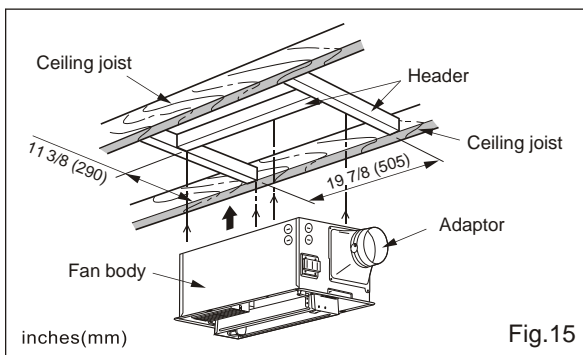

- Follow step 5 of installation I (page 7) to complete the installation work.

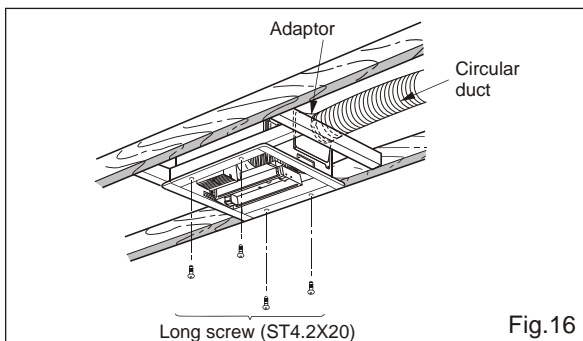

## MAINTENANCE I (CLEANING)

### WARNING:

Disconnect power source before working on unit. Routine maintenance must be done every year.

### CAUTION:

1. Never use petrol, benzene, thinner or any other such chemicals for cleaning the ventilating fan.
2. Do not allow any water to get into the motor.
3. Do not soak resin parts in water over 60°C(140°F).

1. Remove grille. (Squeeze mounting spring and pull down carefully.) ( Fig.17 )
2. Wash and clean grille. (Use non-abrasive kitchen detergent, wipe dry with new cloth.) ( Fig.18 )
3. Remove dust and dirt from fan body using a vacuum cleaner. ( Fig.19 )
4. Using a cloth dampened with kitchen detergent, remove any dirt from fan body. Wipe dry with new cloth. ( Fig.20 )
5. Replace grille.

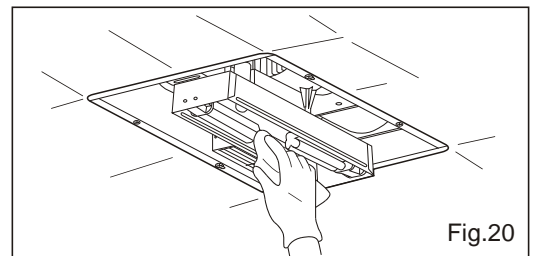
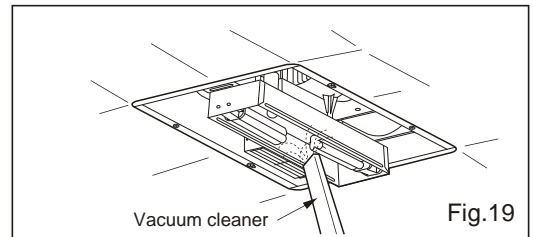
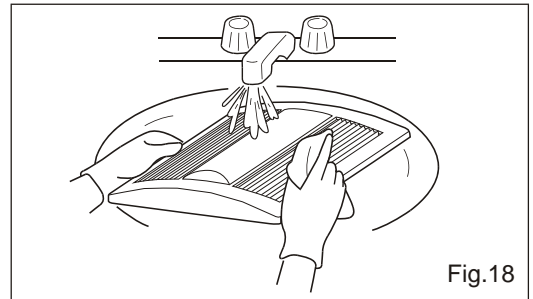
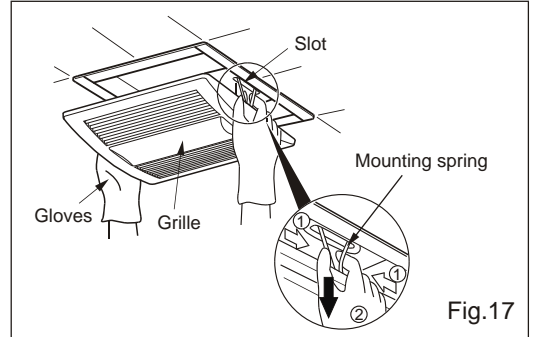

## MAINTENANCE II (REPLACEMENT OF LAMP)

### WARNING:

1. Disconnect power source before working on unit.
2. 4W night lamp has threaded base. Remove by turning counter-clockwise.
3. The lamp's glass is fragile. Please handle with care. To remove lamp, grasp at base and move back and force to loosen. Do not pull hard on the lamp or you may break the glass.
4. Be sure to remove the night lamp before removing fluorescent lamps.

1. Remove grille. (Squeeze mounting spring and pull down.) (Fig.17 of page 10)

2. Remove the 4 W night lamp.(Fig.21)

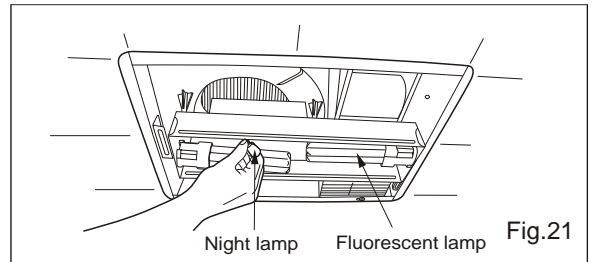

3. Change the fluorescent lamps (FDS18E35/4, 18 W) (Fig.22) or the 4 W night lamp(Fig.21), replace the grille.

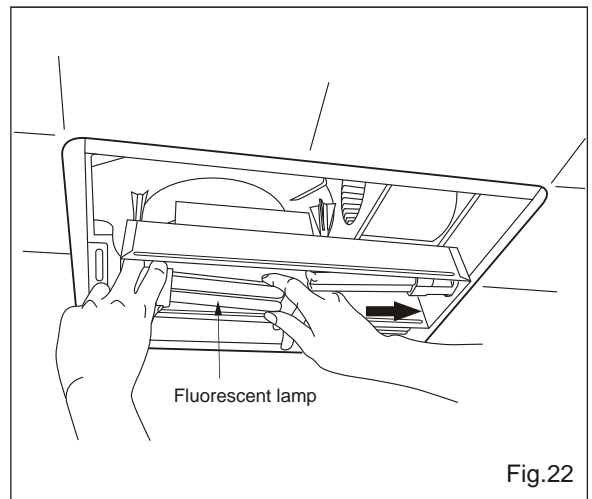

---

## PRACTICAL GUIDE TO INSTALLATION

---

Properly insulate the area around the fan to minimize building heat loss and gain. (Fig.23)

Loose fill or batt insulation can be placed directly over the fan housing in the attic. Panasonic fans and fan/light combination units do not create excessive heat that is a common problem with recessed light fixtures or some competitors' fan/light combinations. Our efficient, cool-running motors and our fluorescent lamps do not create enough ambient heat to be subjected to these limitations.

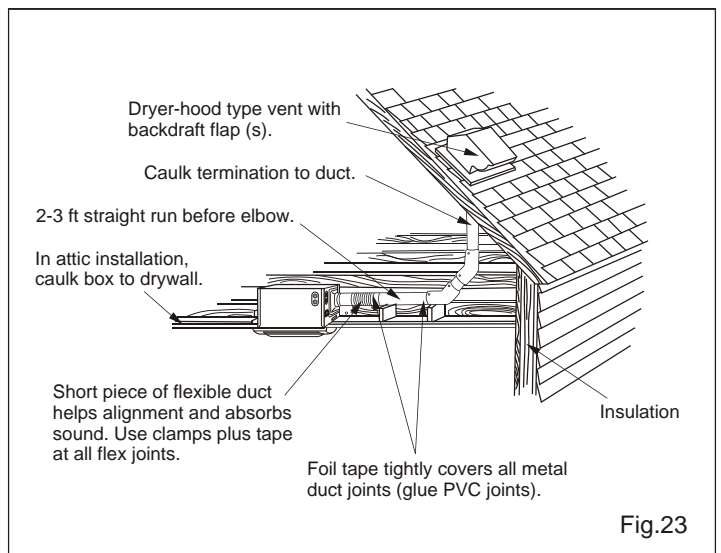

---

## PRODUCT SERVICE

---

### Warning Concerning Removal of Covers.

The unit should be serviced by qualified technicians only. No service information is provided for customers. Your product is designed and manufactured to ensure a minimum of maintenance. However, should your unit ever require service, a nationwide system of factory service centers and AUTHORIZED INDEPENDENT SERVICE CENTERS is maintained to support your product's warranty. (In the U.S.A., call 1-866-292-7292 to Customer call Center.)

---

### PANASONIC CONSUMER ELECTRONICS COMPANY

Division of Panasonic Corporation of North America,  
One Panasonic Way, Secaucus, NJ 07094  
[www.panasonic.com](http://www.panasonic.com)

### PANASONIC CANADA INC.

5770 Ambler Drive, Mississauga, ON L4W 2T3  
[www.panasonic.ca](http://www.panasonic.ca)