

This Owner's Manual is provided and hosted by [Appliance Factory Parts](#).



PANASONIC MC-CG887 Owner's Manual

[Shop genuine replacement parts for PANASONIC
MC-CG887](#)



[Find Your PANASONIC Vacuum Cleaner Parts - Select From 605 Models](#)

----- Manual continues below -----

Panasonic®

VACUUM CLEANER
Aspirateur
Aspiradora

MC-CG887 MC-CG885

Operating Instructions
Manuel d'utilisation
Instrucciones de operación

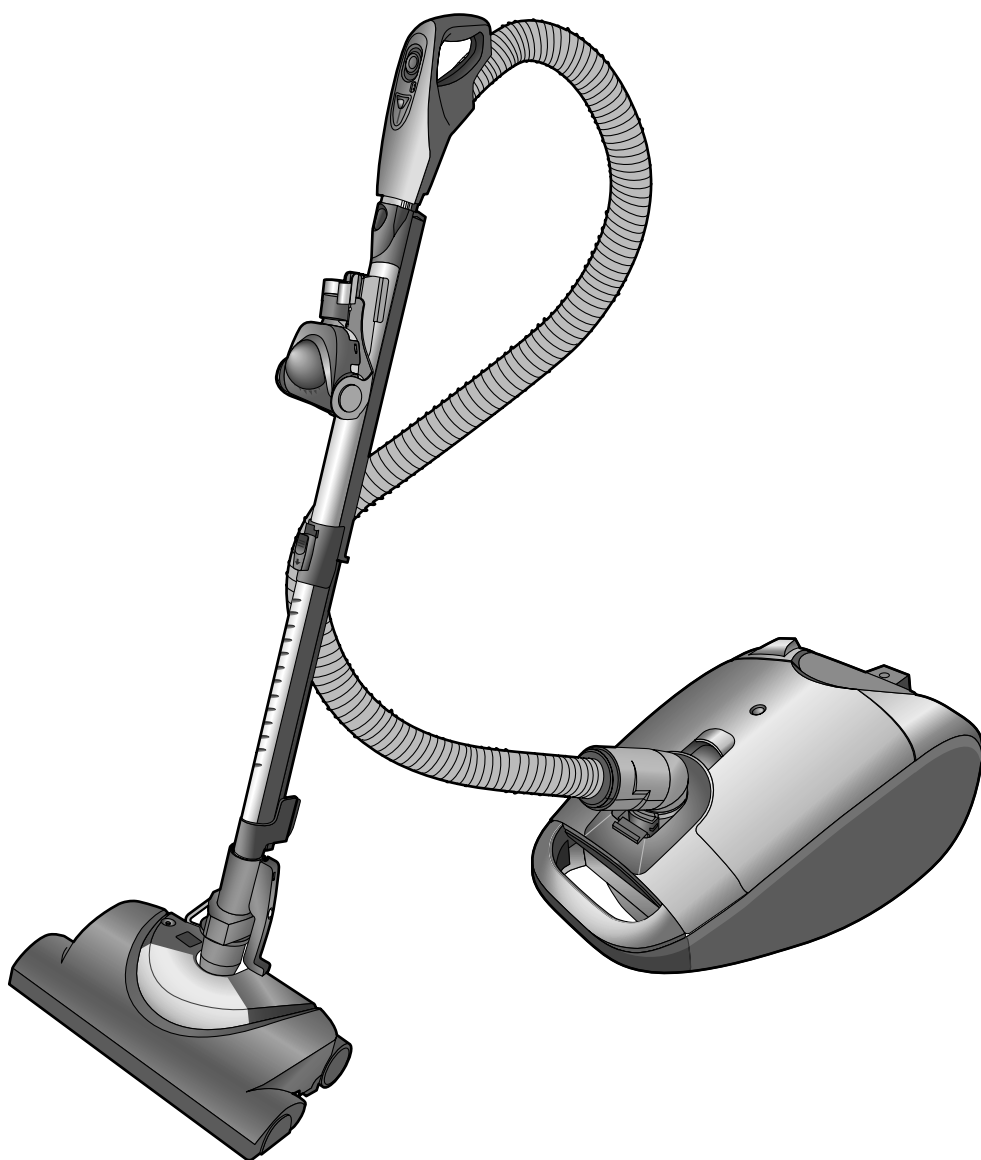

Before operating your vacuum cleaner, please read these instructions completely.

Avant d'utiliser l'appareil, il est recommandé de lire attentivement ce manuel.

Antes de usar su aspiradora, lea completamente estas instrucciones por favor.

CONSUMER INFORMATION

Please read **IMPORTANT SAFETY INSTRUCTIONS** on page 2 before use. Read and understand all instructions.



TO OUR VALUED CUSTOMER

We are very pleased to welcome you to the Panasonic family of products. Thank you for purchasing this product. Our intent is that you become one of our many satisfied customers.

Proper assembly and safe use of your vacuum cleaner are your responsibilities. Your vacuum cleaner is intended only for household use. The vacuum cleaner should be stored in a dry, indoor area. Read the Operating Instructions carefully for important use and safety information.

Special care is required when vacuuming certain types of carpet or floor covering. Always check the carpet or floor covering manufacturer's recommended cleaning instructions before vacuuming.

PLEASE PAY CLOSE ATTENTION TO ALL WARNING AND CAUTION STATEMENTS.

 WARNING	statements are designed to alert you to the possibility of personal injury, loss of human life, and/or damage to the vacuum cleaner and/or personal property if the instructions given are not followed.
 CAUTION	statements are designed to alert you to the possibility of damage to the vacuum cleaner and/or personal property if the instructions given are not followed.
 WARNING	TO AVOID ELECTRICAL SHOCK Never vacuum damp or wet surfaces or liquids. DO NOT store vacuum cleaner outdoors. Replace worn or frayed power cord immediately. Unplug from outlet when not in use and before servicing. TO AVOID ACCIDENTS Except for hand-held cleaners, keep vacuum cleaner on floor - not chairs, tables, steps, stairs, etc. Store vacuum cleaner promptly after each use to prevent accidents such as tripping over power cord or vacuum cleaner. Use vacuum cleaner and accessories only in a manner intended by the manufacturer. The use of an extension cord is not recommended.

IMPORTANT SAFETY INSTRUCTIONS

When using your vacuum cleaner, basic precautions should always be followed
READ ALL INSTRUCTIONS BEFORE USING THIS VACUUM CLEANER

WARNING

To reduce the risk of fire, electric shock, or injury:

- **DO NOT** leave vacuum cleaner plugged in when not in use. Unplug from outlet when not in use and before servicing.
- To reduce the risk of fire, or electric shock - **DO NOT** use outdoors or on wet surfaces.
- **DO NOT** allow to be used as a toy. Close attention is necessary when used by or near children.
- Use only as described in this manual. Use only manufacturer's recommended attachments.
- **DO NOT** use with damaged cord or plug. If vacuum cleaner is not working as it should, or if it has been dropped, damaged, left outdoors, or dropped into water, return it to an Authorized Panasonic Service Center.
- **DO NOT** pull or carry by cord, use cord as a handle, close door on cord, or pull cord around sharp edges or corners. Do not run vacuum cleaner over cord. Keep cord away from heated surfaces.
- Hold plug when rewinding onto cord reel. **DO NOT** allow plug to whip when rewinding.
- **DO NOT** unplug by pulling on cord. To unplug, grasp the plug, not the cord.
- **DO NOT** handle plug or vacuum cleaner with wet hands.
- **DO NOT** put any objects into openings. **DO NOT** use with any opening blocked; keep free of dust, lint, hair, and anything that may reduce air flow.
- Keep hair, loose clothing, fingers, and all parts of body away from openings and moving parts.
- **DO NOT** pick up anything that is burning or smoking, such as cigarettes, matches, or hot ashes.
- **DO NOT** use without dust bag and/or filters in place.
- Turn off all controls before unplugging.
- Use extra care when cleaning on stairs.
- **DO NOT** use vacuum cleaner to pick up flammable or combustible liquids such as gasoline or use in areas where they may be present.
- **DO NOT** operate vacuum cleaner with punctured hose. The hose contains electrical wires. Replace if cut or worn. Avoid picking up sharp objects.
- Always turn off vacuum cleaner before connecting or disconnecting the hose or Power Nozzle.

SAVE THESE INSTRUCTIONS

THIS VACUUM CLEANER IS INTENDED FOR HOUSEHOLD USE ONLY

Note: Before you plug in your Panasonic vacuum cleaner, make sure that the voltage indicated on the rating plate located at the back of the vacuum cleaner is the same as your local supply.

TABLE OF CONTENTS
Table des matières
Tabla de contenido

CONSUMER INFORMATION / IMPORTANT SAFETY INSTRUCTIONS	2
Renseignements importants / Importantes mesures de sécurité	3
Información para el consumidor / Instrucciones importantes de seguridad	4
PARTS IDENTIFICATION	6
Nomenclature	6
Identificación de piezas	6
HOW TO ASSEMBLE YOUR CLEANER	8
ASSEMBLAGE DE VOTRE ASPIRATEUR	9
CÓMO MONTAR LA ASPIRADORA	9
HOW TO OPERATE YOUR CLEANER	10
MODE D'EMPLOI DE VOTRE ASPIRATEUR	11
CÓMO UTILIZAR LA ASPIRADORA	11
MAINTENANCE AND SERVICING	14
MAINTENANCE ET ENTRETIEN	15
MANTENIMIENTO Y REPARACIÓN	15
SPECIFICATIONS	24
SPÉCIFICATIONS	24
ESPECIFICACIONES	24
BEFORE REQUESTING SERVICE	25
Guide de dépannage	26
Antes de pedir servicio	27
WARRANTY	28, 30
Garantie	31
Garantía	29
WHAT TO DO WHEN SERVICE IS NEEDED	32
Service après-vente	32
Cuando necesita servicio	32

PARTS IDENTIFICATION

Nomenclature

Identificación de piezas

Only MC-CG887

Handle with 3 way On/Off switch and Power control switch

MC-CG887 uniquement

Poignée avec commutateur à 3 vitesses et interrupteur principal

Sólo MC-CG887

Mango con selector de encendido/apagado de 3 vías e interruptor de control de potencia

Only MC-CG885

Handle with 3 way On/Off switch

MC-CG885 uniquement

Poignée avec commutateur à 3 vitesses

Only MC-CG885

Mango con selector de encendido/apagado de 3 vías



Mini turbine nozzle

Suceur à mini-turbine

Boquilla de miniturbina



Mini turbine nozzle holder

Support du suceur à mini-turbine

Soporte de la boquilla de miniturbina

Only MC-CG887

Telescopic wand

MC-CG887 uniquement

Bras télescopique

Sólo MC-CG887

Tubo telescópico

Pile height indicator

Indicateur de la hauteur des brosses

Indicator de nivel de pelo de la alfombra

Overload protector

Protecteur de surcharge

Protector contra sobrecargas

Headlight

Dispositif d'éclairage

Luz

Power nozzle

Tête motorisée

Power Nozzle

Wand quick release pedal

Pédale de dégagement du tube

Pedal de liberación rápida del tubo

tubo

Handle release pedal

Pédale de dégagement de l'inclinaison du manche

Pedal de liberación del mango

Pile height pedal

Indicateur de la hauteur des brosses

Indicator de nivel de pelo de la alfombra

Hose

Tuyau

Manguera

Only MC-CG885

Extension wand

MC-CG885 uniquement

Tubes extensibles

Sólo MC-CG885

Tuba extensible

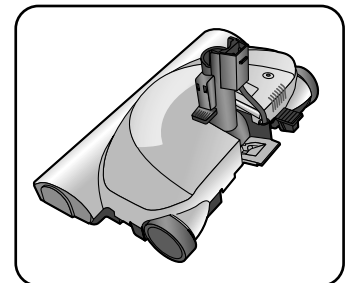
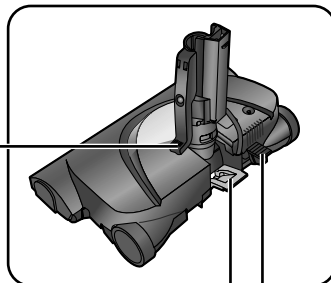
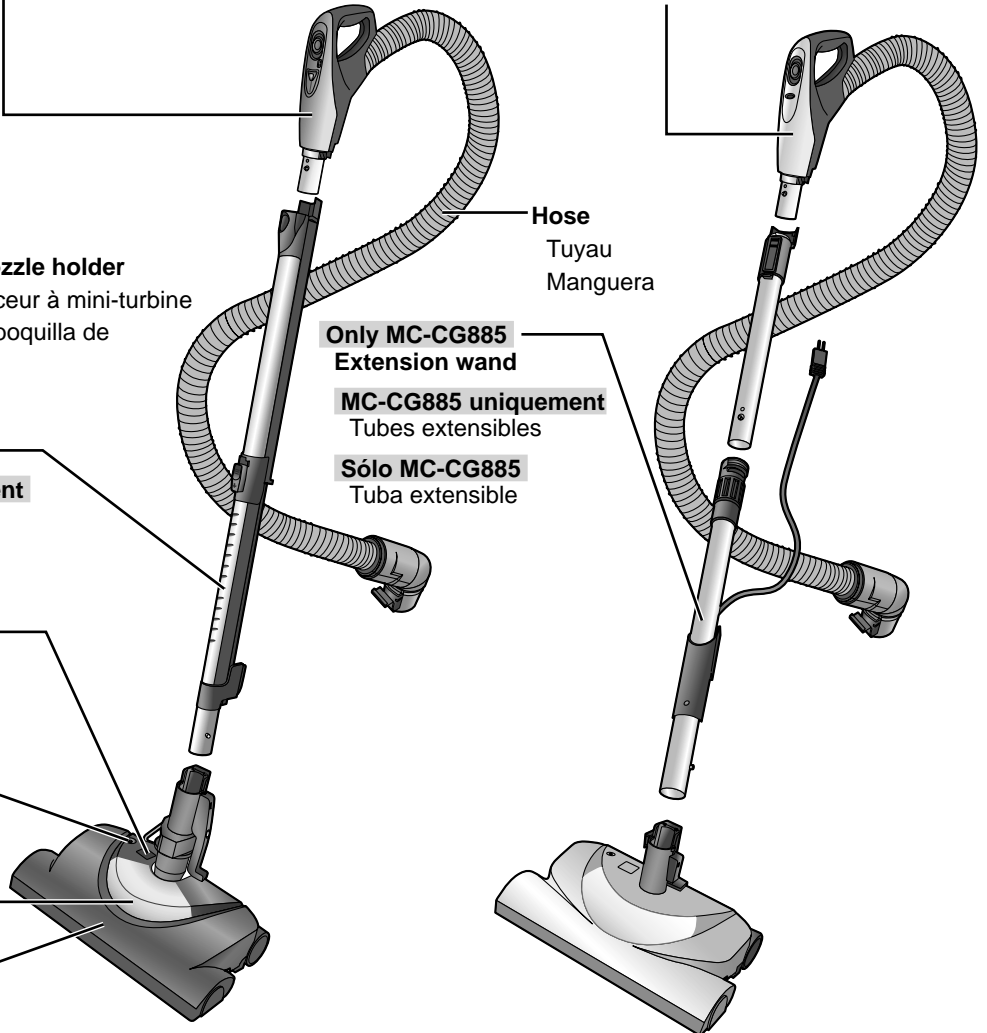

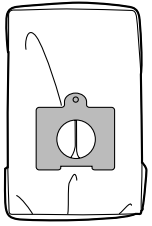

Dust bag
Sac à poussière
Bolsa para polvo



Dust bag holder
Support du sac à
poussière
Soporte de la
bolsa para polvo

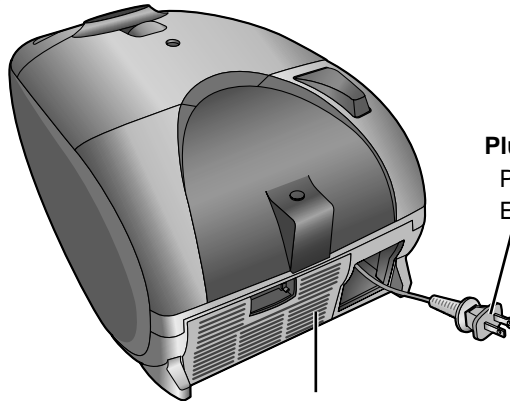

Plug (Power cord)
Prise (Cordon d'alimentation)
Enchufe (Cordón eléctrico)

Exhaust filter cover
Couvercle du filtre d'échappement
Cubierta del filtro de escape

Performance indicator
Indicateur de performance
Indicador de rendimiento

Cord rewind pedal
Bouton de ramasse câble
Pedal de recogida del cable

Crevice tool
Suceur plat
Herramienta para hendiduras

Attachment storage
Logement des accessoires
Almacenamiento para accesorios

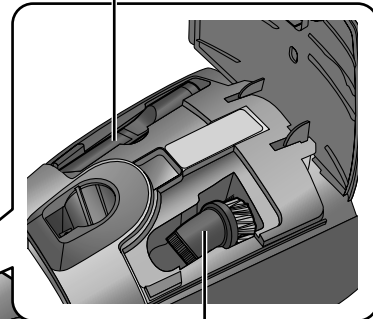

Dusting brush
Brosse à épousseter
Cepillo para sacudir

Hood release
Loquet de dégagement du
couvercle
Pestillo de la tapa

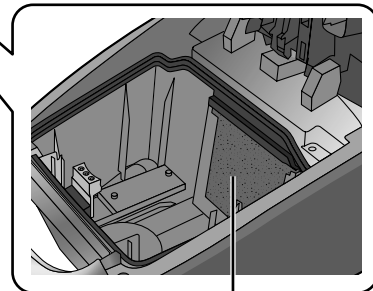

Canister hood
Couvercle du traîneau
Tapa de la aspiradora

Pre-motor filter
Filtre situé avant le moteur
Filtro pre-motor

B-HOW TO ASSEMBLE YOUR CLEANER

⚠ WARNING

Electrical Shock Hazard.
DO NOT plug into electrical supply until assembly is complete.
Failure to do so could result in electrical shock or injury.

B-1

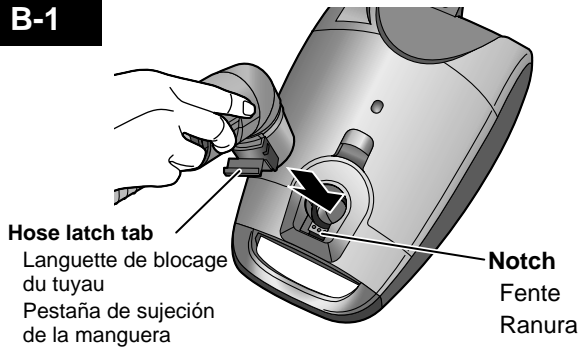

- B-1** Line up the hose latch tab and notch in canister hood and insert the hose into the canister until it snaps in place.
To remove: Do not open hood before removing hose. With hood closed, lift hose latch tab upward and pull on hose.

B-2

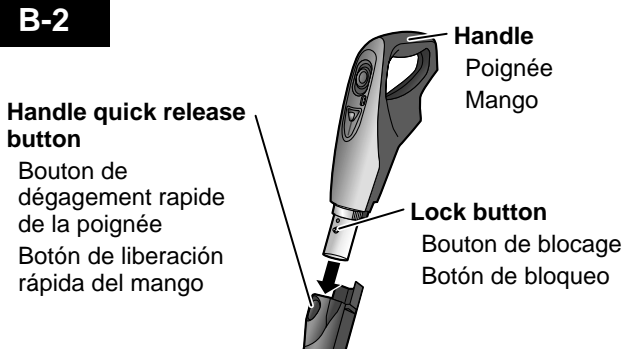

- B-2** Insert the handle into the wand until lock button snaps in place. Be sure the hose is not twisted.
To remove: Press the handle quick release button and pull out the handle.
To store: Disconnect the hose from the wands and canister to prevent stress on hose during storage. Store the hose in a loosely coiled position so the hose covering is not stressed.

B-3

Only MC-CG887
MC-CG887 uniquement
Sólo MC-CG887

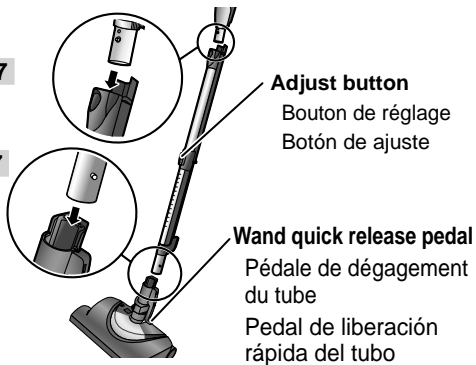

- B-3** To adjust, simply push down on the wand adjust button and slide the upper wand to the desired length.
To remove: Press wand quick release pedal. Pull wands out of power nozzle.

B-4

Only MC-CG885
MC-CG885 uniquement
Sólo MC-CG885

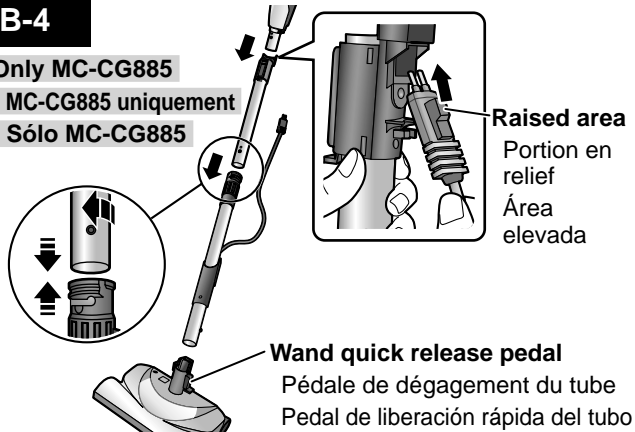

- B-4** Slide wands together until wand button snaps into place. Turn wand button to slotted area of wand swivel. Insert wands into power nozzle until the button snaps into place.
 Connect power nozzle plug and cord as shown. Raised area of plug must face toward hand.
To remove: Press wand quick release pedal. Pull wands out of power nozzle.

B-HOW TO ASSEMBLE YOUR CLEANER

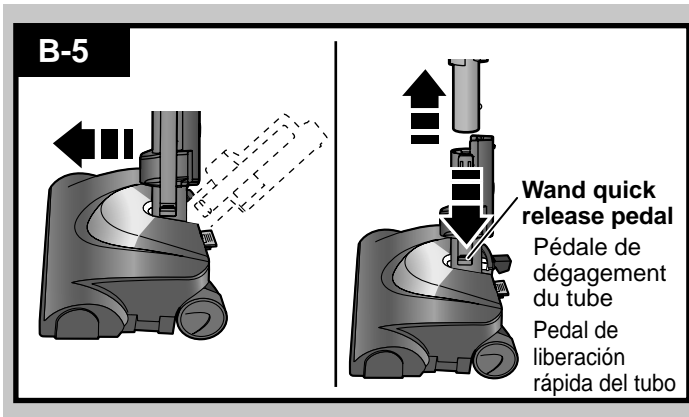

- B-5** If the power nozzle is attached, turn vacuum cleaner off before removing plug from wands. To remove wands from power nozzle, lock wands in upright position. Press wand quick release pedal with foot and pull the wands straight up out of power nozzle.

C-HOW TO OPERATE YOUR CLEANER

⚠ WARNING

Personal Injury and Product Damage Hazard

- **DO NOT** plug in if switch is in **ON** position. Personal injury or property damage could result.
- The cord moves rapidly when rewinding. Keep children away and provide a clear path when rewinding the cord to prevent personal injury.
- **DO NOT** use outlets above counters. Damage from the cord to items in surrounding area could occur.

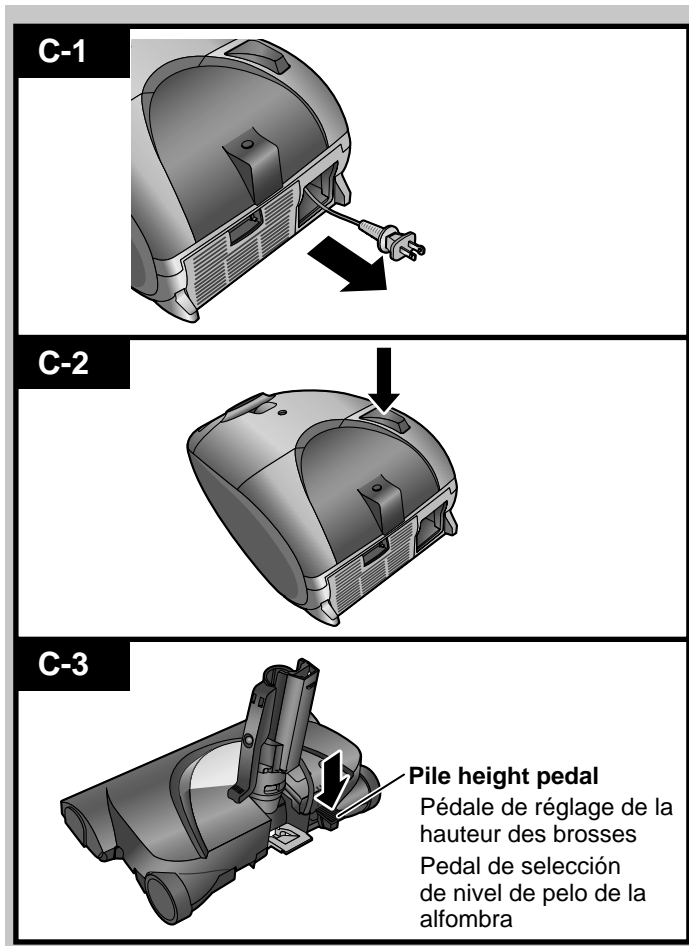

- C-1** Pull the cord out of the canister to desired length. The cord will not rewind until the cord rewind pedal is pushed.
- C-2** Unplug the vacuum cleaner. Hold the plug while rewinding to prevent damage or injury from the moving cord. Push the cord rewind pedal.
- C-3** Select a pile height setting by pressing the pile height pedal. The pile height setting shows on the indicator.

C-HOW TO OPERATE YOUR CLEANER

C-4

(MC-CG887)

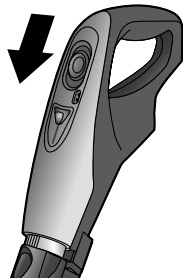

(MC-CG885)

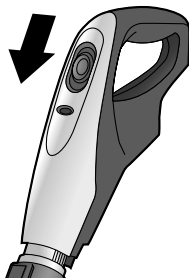

C-4 Select a switch position on the handle.

OFF

FLOOR: turns on the canister motor only.

CARPET: turns on both the canister and the power nozzle motors and turns on the canister headlight

Adjust the power level (Only MC-CG887).

Sliding the switch to adjust the power.

NOTE: When this switch is in the FLOOR position, the headlight and dirt sensors DO NOT function since no electricity flows to the power nozzle.

C-5

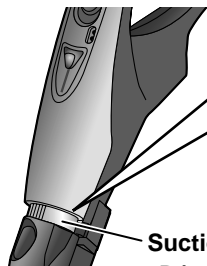

Decrease suction

Diminution de l'aspiration
Disminuir aspiración



Increase suction

Augmentation de l'aspiration
Aumentar aspiración

Suction control

Régulateur d'aspiration

Control de aspiración

C-5 SUCTION CONTROL

The suction control allows you to change the vacuum cleaner suction for different fabrics and carpet weights. Opening the control decreases suction for draperies and lightweight rugs, while closing the control increases suction for upholsteries and carpets.

C-6

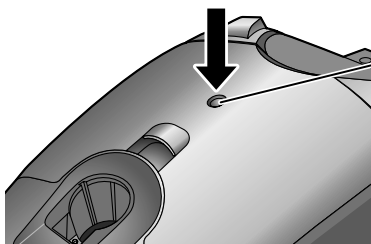

Performance indicator

Indicateur de performance
Indicador de rendimiento

C-6 PERFORMANCE INDICATOR

When the vacuum cleaner is running with normal airflow, color on the performance indicator is clear. The red color comes on whenever the airflow becomes blocked. If that occurs, check the disposable dust bag, pre-motor filter and other possible clog locations.

C-7

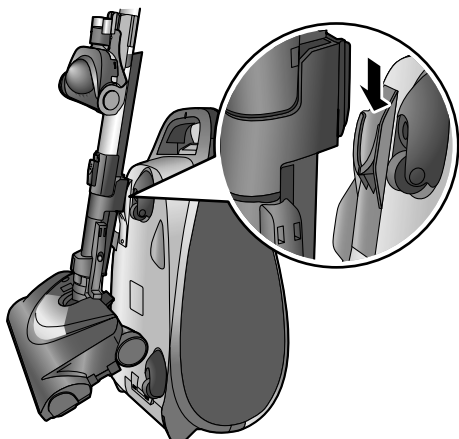

C-7 STORAGE POSITION

Slide the wand holder attached to the nozzle pipe straight into the wand supporter on the left side of the canister bottom.

⚠ CAUTION

DO NOT leave the Power nozzle running in one spot in the upright position for any length of time. Damage to carpet may occur.

Note: Refer to your carpet manufacturers cleaning recommendations. Some more delicate carpets may require that they be vacuumed with the Power nozzle agitator turned off to prevent carpet damage.

⚠ WARNING

- Disconnect the electrical supply before cleaning or maintaining the vacuum cleaner.
- To avoid injury, keep your fingers and hands away from the beater bar.

Indicator for replacing the dust bag

Turn the power control to the highest setting and lift the nozzle off the floor. If the dust indicator turns red, the dust bag is full and requires replacing the dust bag.

NOTE: If the dust bag is not properly installed, the dust cover will not close. Be sure to check that the dust bag is properly installed before operating the vacuum cleaner, otherwise dust will leak out. The dust bag can easily lay on the dust cover packing or clip between the bag collar and the body, so be sure to properly extend it into the body of the vacuum cleaner.

Replacing the dust bag

Before replacing the dust bag, turn off and unplug vacuum cleaner, remove hose from canister.

- D-1** Lift the hood release and raise the dust cover until it clicks properly.
- D-2** Remove the basket and throw away the dust bag.

- D-3** Set the basket first to the vacuum cleaner and set a new dust bag back to the basket.

- D-4** Close the dust cover properly until you hear it click.

D-1

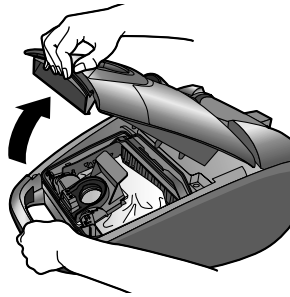
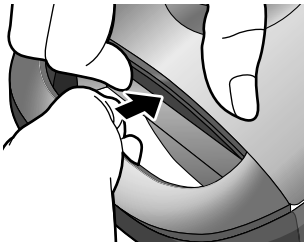

D-2

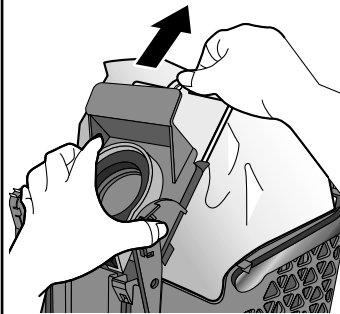
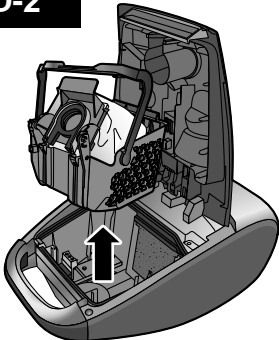

D-3

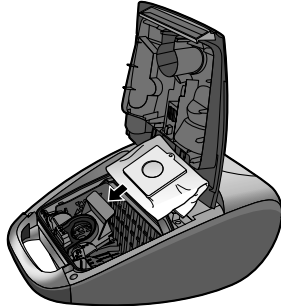
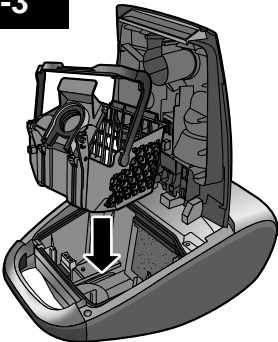

D-4

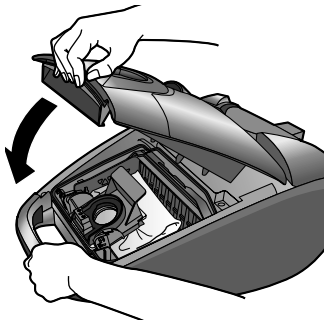

Power nozzle care

Always follow all safety precautions before performing maintenance to the power nozzle.

! WARNING

- **Electrical Shock or Personal Injury Hazard.**
- **Disconnect the electrical supply before performing maintenance to the vacuum cleaner. Failure to do so could result in electrical shock or personal injury from vacuum cleaner suddenly starting.**

Inspect once a month.

D-5 Unscrew the two agitator cover screws on the bottom of the power nozzle.

D-5

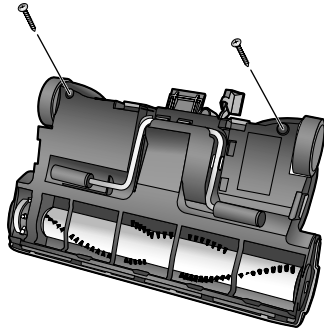

D-6

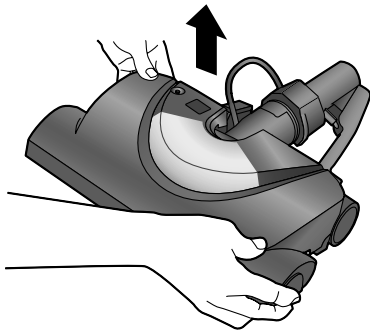

D-6 To remove the power nozzle cover, grasp the side latches and pull out first. Then grasp the rear latches and pull out.

D-7

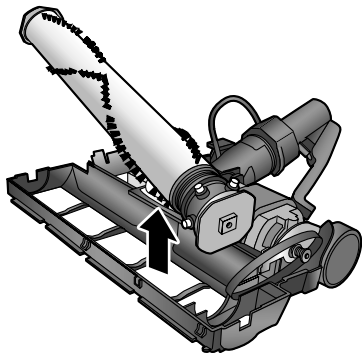

D-7 Lift agitator assembly out and remove the belt. Using an old tooth brush or similar tool, clean any dirt or lint from the brush.

D-8

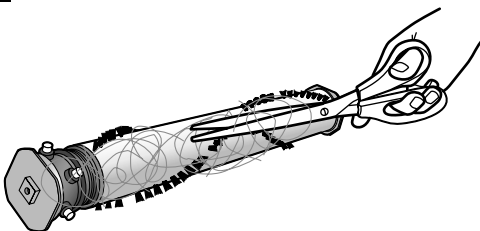

D-8 Then cut across threads, strings, hairs, etc. from the beater bar with a pair of scissors. (Removal as per reverse procedure)

NOTE: Take care not to cut the brush. Do not wash in water.

Brush Servicing

⚠ WARNING

- **Electrical Shock or Personal Injury Hazard**
- **Disconnect electrical supply before performing maintenance to the vacuum cleaner. Failure to do so could result in electrical shock or personal injury from vacuum cleaner suddenly starting.**

D-9

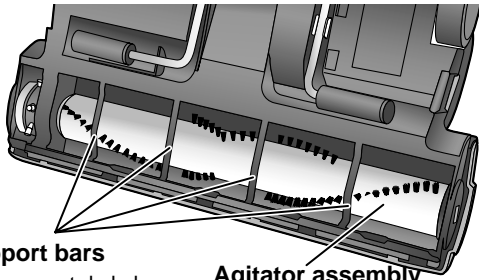

Base support bars

Barres de support de la base
Barra de soporte de la base

Agitator assembly

Assemblage de l'agitateur
Ensamble del agitador

D-9

TO CHECK BRUSHES:

When brushes are worn to the level of the base support bar, replace the brush dowel.

TO REPLACE AGITATOR ASSEMBLY

Remove power nozzle cover, agitator cover, belt and agitator assembly. (See "Power nozzle care").

Replace agitator assembly.

Replace belt, agitator cover, power nozzle cover and screws.

D-10

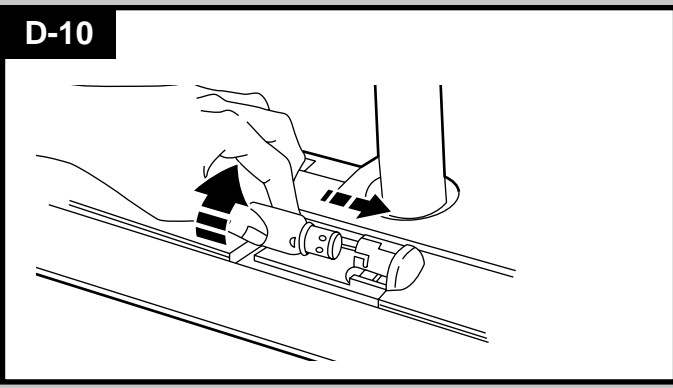

D-10

- Remove power nozzle cover.
Push in and turn bulb counterclockwise to remove.
Replace the bulb.
Only use a bulb rated 130 V AC-15 Watts.
Replace power nozzle cover.

Replacing Headlight Bulb

D-11

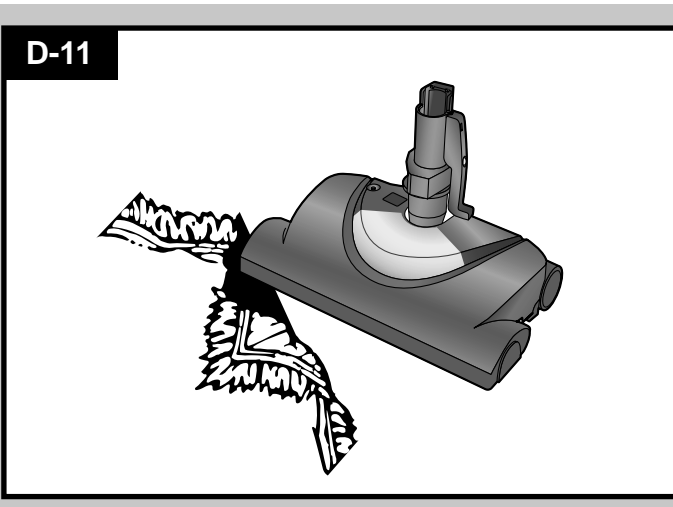

D-11

Overload Protector

The overload protector stops the power nozzle motor when the brush jams and prevents belt breakage.
NOTE: Canister motor will continue to run.

TO CORRECT PROBLEM:

Unplug electrical cord.
Check brush and brush support areas for excessive lint build-up or jamming.
Clean jammed area.

TO RESET:

Press reset button on top of the power nozzle. Plug in and turn on vacuum cleaner.

D - MAINTENANCE AND SERVICING

D-12

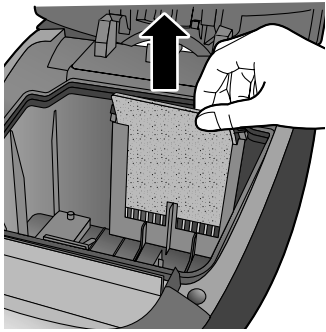

D-13



D-14

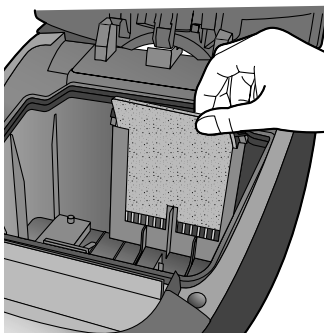

Maintaining the Pre-motor filter

Follow the procedure written below when the suction power is not restored after replacing the dust bag.

D-12 Remove the pre-motor filter.

D-13 Wash gently with water and then allow to dry in a shaded location.

D-14 Return the pre-motor filter to its original position.
NOTE: Make sure you remember to replace the filter. If the filter is not installed, it will cause motor failure.

- Do not wash the filter in a washing machine or dry it with a dryer or other source of hot air.

! CAUTION

- **NEVER REUSE A DUST BAG.**
Very fine materials, such as carpet freshener, face powder, fine dust, plaster, soot, new carpet lint, etc., can clog the bag and cause it to burst before it is full and may cause damage to vacuum cleaner motor. Change bag more often when vacuuming these materials.
- **DO NOT** use hot air or hot surface to dry filters. Keep at room temperature for approximately 24 hours.
- **IMPORTANT:** Before re-installing the washable filters, make sure they are completely dry to avoid damaging the cleaner.

D-15

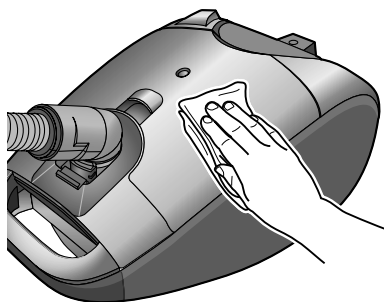

Vacuum cleaner body

D-15 Wipe with a soft cloth soaked with water.

D-16

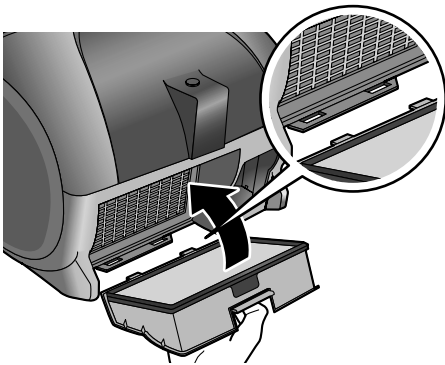
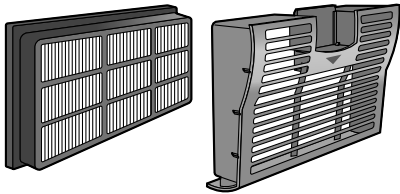
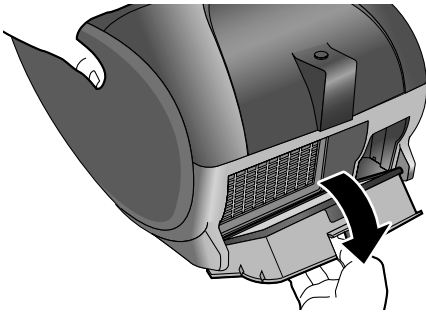

Exhaust filter

- D-16** Exhaust filter is installed in the rear side of the vacuum cleaner. This filter retains small dust particles which may be present in the expelled air. It is advisable to change the exhaust filter when it becomes dirty. To change the exhaust filter, hold the exhaust cover (as illustrated) and pull it out. After changing the filter, set the exhaust cover to original position (as illustrated).

IMPORTANT: Never use the vacuum cleaner without the correct filters properly installed. Failure to do so may result in damage to the motor.

What to do if your cleaner does not work

Check that the vacuum cleaner is correctly plugged in and that the socket outlet is working.

This vacuum cleaner has a thermal protector which automatically trips to protect the vacuum cleaner from overheating.

If the thermal protector device has operated, wait until it resets automatically after approximately 60 minutes. If after having checked the above mentioned points, the vacuum cleaner does not work, take it to an Authorized Service Centre to be repaired.

What to do when the suction performance reduces

- Stop the vacuum cleaner and unplug from the socket outlet.
- Check whether the wands, hose and accessories are blocked or not.
If they are blocked, remove the obstruction.
- Check whether the paper dust bag is full. If it is full, replace it .
- Check whether the pre-motor filter or exhaust filter is blocked with dust.
If they are blocked, clean them out or replace them.

SPECIFICATIONS

	MC-CG887	MC-CG885
Power source	120 V~60 Hz	
Current	12 Amps	
Dimensions (W x L x H)	312 mm x 489 mm x 243 mm	
Net weight	6.5 kg	
Extension wands	Telescopic	Metal x 2
Dusting brush	√	√
Crevice tool	√	√
mini turbine nozzle	√	-

Optional Accessory

Product name	Model number
Dust bag (PACK 4/u.)	C-18

REMINDER FOR CUSTOMER

The model and serial number of this product may be found on the nameplate located on the underside of your vacuum cleaner.

You should note the model and serial number in the spaces provided and retain this book as a permanent record of your purchase.

Model Number.

Serial No.

Date Purchased.

Where Purchased.

SPÉCIFICATIONS

	MC-CG887	MC-CG885
Alimentation	120 V~60 Hz	
Courant	12 Amps	
Dimensions (l x L x H)	312 mm x 489 mm x 243 mm	
Poids net	6.5 kg	
Tubes extensibles	Télescopique	Métal x 2
Brosse à épousseter	√	√
Suceur plat	√	√
Suceur à mini-turbine	√	-

Accessoire en option

Nom du produit	N° de Modèle.
Sac à poussière (paquet de 4)	C-18

RAPPEL DE VOTRE ACHAT

Pour toute réclamation ou information concernant cet appareil, nous vous recommandons de prendre note des renseignements détaillés. Les numéros de série et modèle se trouvent sur la plaque des caractéristiques située sur la partie inférieure de l'appareil.

N° de Modèle.

N° de Série.

Date d'achat.

Lieu d'achat.

ESPECIFICACIONES

	MC-CG887	MC-CG885
Alimentación	120 V~60 Hz	
Corriente	12 Amps	
Dimensiones (A x L x Al)	312 mm x 489 mm x 243 mm	
Peso neto	6.5 kg	
Tuba extensible	Telescopic	Metal x 2
Brocha pequeña	√	√
Herramienta para hendiduras	√	√
boquilla de miniturbina	√	-

Accesorio opcional

Nombre del producto	N° de Modelo
Bolsa para polvo (set de 4 unidades)	C-18

AVISO PARA EL CLIENTE

El número de serie y modelo, se encuentran en la placa de características situada en la parte inferior del aparato.

El número de serie y modelo, se encuentran en la placa de características situada en la parte inferior de del aparato.

N° de Modelo.

N° de Serie.

Fecha de compra.

Lugar de compra.

BEFORE REQUESTING SERVICE

WARNING Electric Shock or Personal Injury Hazard.

Disconnect the electrical supply before performing maintenance to the vacuum cleaner. Failure to do so could result in electric shock or personal injury from vacuum cleaner suddenly starting.

Review this chart to find do-it-yourself solutions for minor performance problems. Any service needed, other than those described in these Operating Instructions, should be performed by an authorized service representative.

PROBLEM	POSSIBLE CAUSE	POSSIBLE SOLUTION
Vacuum cleaner won't start.	<ol style="list-style-type: none"> 1. Unplugged at wall outlet. 2. Tripped circuit breaker/blown fuse at household service panel. 3. Loose hose electrical connections. 	<ol style="list-style-type: none"> 1. Plug in firmly, push ON/OFF switch to ON. 2. Reset circuit breaker or replace fuse. 3. Reconnect hose ends.
Poor job of dirt pick-up.	<ol style="list-style-type: none"> 1. Full or clogged dust bag. 2. Clogged airflow passages. 3. Dirty pre-motor filter. 4. Wrong pile height setting. 5. Open suction control. 6. Hole in hose. 7. Worn power nozzle brushes. 8. Canister hood open. 	<ol style="list-style-type: none"> 1. Change bag. 2. Clear airflow passages. 3. Maintaining the pre-motor filter. 4. Adjust setting. 5. Adjust control. 6. Replace hose. 7. Replace agitator. 8. Close and latch hood.
Power Nozzle will not run when attached.	<ol style="list-style-type: none"> 1. Power nozzle connections unplugged. 2. Tripped overload protector in power nozzle. 	<ol style="list-style-type: none"> 1. Plug in firmly. 2. Remove any items that may be caught or jammed, then reset. If vacuum cleaner starts and stops again, clean agitator and end caps, then reset.
Any, some, or all red lights in dirt sensor burn and never turn clear.	<ol style="list-style-type: none"> 1. Dirt passage is clogged. 	<ol style="list-style-type: none"> 1. Check for clogs in air passages.
Performance indicator is red.	<ol style="list-style-type: none"> 1. Full or clogged dust bag. 2. Dirty pre-motor filter. 3. Clogged airflow passage. 4. Certain attachment tools. 	<ol style="list-style-type: none"> 1. Change bag. 2. Maintaining the pre-motor filter. 3. Clear clog from airflow passage. 4. This is normal. Light should go off when tool is removed.
Vacuum Cleaner picks up moveablerugs -or- Power Nozzle pushes too hard.	<ol style="list-style-type: none"> 1. Wrong pile height setting. 2. Suction too strong. 	<ol style="list-style-type: none"> 1. Adjust setting. 2. Open suction control.
Light won't work.	<ol style="list-style-type: none"> 1. Burned out light bulb. 	<ol style="list-style-type: none"> 1. Change light bulb.
Cord won't rewind.	<ol style="list-style-type: none"> 1. Dirty power cord. 2. Cord jammed. 	<ol style="list-style-type: none"> 1. Clean the power cord. 2. Pull out cord and rewind.

WARRANTY

Panasonic Vacuum Cleaner Limited Warranty

Panasonic Consumer Electronics Company (collectively referred to as "the warrantor") will repair this product with new or refurbished parts free of charge, in the U.S.A. or Puerto Rico for one (1) years from the date of original purchase in the event of a defect in materials or workmanship.

This Limited Warranty Excludes both Labor and Parts for the following items which require normal replacement: Disposable Dust Bag, Filters, Belts, Light Bulbs, Agitator Brushes and Batteries (if supplied).

Carry-in or mail-in service in the U.S.A. can be obtained during the warranty period by contacting a Panasonic Services Company (PASC) Factory Servicenter listed in the Servicenter Directory. Or call, toll free, 1-800-211-PANA (7262) to locate a PASC Authorized Servicenter. Carry-in or mail-in service in Puerto Rico can be obtained during the warranty period by calling the local Panasonic Sales Company telephone number listed in the Servicenter Directory.

This warranty is extended only to the original purchaser. A purchase receipt or other proof of date of original purchase will be required before warranty performance is rendered.

This warranty only covers failures due to defects in materials and workmanship which occur during normal use and does not cover damages which occur in shipment, or failures which are caused by products not supplied by the warrantor, or failures which result from accident, misuse, abuse, neglect, bug infestation, mishandling, misapplication, faulty installation, improper operation or maintenance, alteration, modification, power line surge, improper voltage supply, lightning damage, commercial use such as hotel, office, restaurant or other business or rental use of the product, or service by anyone other than a PASC Authorized Servicenter, or damage that is attributable to acts of God.

LIMITS AND EXCLUSIONS:

There are no express warranties except as listed above.

THE WARRANTOR SHALL NOT BE LIABLE FOR INCIDENTAL OR CONSEQUENTIAL DAMAGES RESULTING FROM THE USE OF THIS PRODUCT, OR ARISING OUT OF ANY BREACH OF THIS WARRANTY. ALL EXPRESS AND IMPLIED WARRANTIES, INCLUDING THE WARRANTIES OF MERCHANTABILITY AND FITNESS FOR A PARTICULAR PURPOSE, ARE LIMITED TO THE APPLICABLE WARRANTY PERIOD SET FORTH ABOVE.

Some states do not allow the exclusion or limitation of incidental or consequential damages, or limitations on how long an implied warranty lasts, so the above exclusions or limitations may not apply to you.

This warranty gives you specific legal rights and you may also have other rights which vary from state to state. If a problem with this product develops during or after the warranty period, you may contact your dealer or Servicenter. If the problem is not handled to your satisfaction, then write to the Consumer Affairs Department at the listed address on the back cover.

WARRANTY

Panasonic Canada Inc.
5770 Ambler Drive, Mississauga, Ontario L4W 2T3

Panasonic Vacuum Cleaner Limited Warranty

Panasonic Canada Inc. warrants this product to be free from defects in material and workmanship and agrees to remedy any such defect for a period as stated below from the date of original purchase.

Vacuum Cleaner - One (1) years, parts and labour

In-home Service will be carried out only to locations accessible by roads and within 50 km of an authorized Panasonic service facility.

LIMITATIONS AND EXCLUSIONS

This warranty does not apply to products purchased outside Canada or to any product which has been improperly installed, subjected to usage for which the product was not designed, misused or abused, damaged during shipping, or which has been altered or repaired in any way that affects the reliability or detracts from the performance, nor does it cover any product which is used commercially. Dry cell batteries are also excluded from coverage under this warranty. This warranty is extended to the original end user purchaser only. A purchase receipt or other proof of date of original purchase is required before warranty service is performed.

THIS EXPRESS, LIMITED WARRANTY IS IN LIEU OF ALL OTHER WARRANTIES, EXPRESS OR IMPLIED, INCLUDING ANY IMPLIED WARRANTIES OF MERCHANTABILITY AND FITNESS FOR A PARTICULAR PURPOSE. IN NO EVENT WILL PANASONIC CANADA INC. BE LIABLE FOR ANY SPECIAL, INDIRECT OR CONSEQUENTIAL DAMAGES.

In certain instances, some jurisdictions do not allow the exclusion or limitation of incidental or consequential damages, or the exclusion of implied warranties, so the above limitations and exclusions may not be applicable.

WARRANTY SERVICE

FOR PRODUCT OPERATION ASSISTANCE, please contact:

Our Customer Care Centre:	Telephone #:	(905) 624-5505
	1-800 #:	1-800-561-5505
	Fax #:	(905) 238-2360
	Email link:	"Contact Us" on www.panasonic.ca

FOR PRODUCT REPAIRS, please locate your nearest Authorized Servicentre at www.panasonic.ca :

Link : "ServicentresTM locator" under "Customer support"

IF YOU SHIP THE PRODUCT TO A SERVICENTRE

Carefully pack and send prepaid, adequately insured and preferably in the original carton.
Include details of the defect claimed, and proof of date of original purchase.

WHAT TO DO WHEN SERVICE IS NEEDED

If your Panasonic Vacuum Cleaner needs service, look in the yellow pages of the telephone book under HOME APPLIANCE SERVICE for your nearest Panasonic Services Company ("PASC") Factory Servicenter, or PASC authorized Servicenter, or call, 1-800-211-PANA (7262) toll free to find a convenient servicenter. **DO NOT send the product to the Executive or Regional Sales offices. They are NOT equipped to make repairs.**

If you ship the product

Carefully pack and send it prepaid, adequately insured and preferably in the original carton. Attach a postage-paid letter to the outside of the carton, which contains a description of your complaint. **DO NOT send the product to the Executive or Regional Sales Offices. They are NOT equipped to make repairs.**

PANASONIC CONSUMER ELECTRONICS COMPANY DIVISION OF PANASONIC CORPORATION OF NORTH AMERICA

One Panasonic Way
Secaucus, New Jersey 07094
World Wide Web Address
<http://www.panasonic.com>

What to do when service is needed Service après-vente (Canada)

WARRANTY SERVICE

For product operation and information assistance, please contact your Dealer or our Customer Care Centre at:
Telephone #: (905) 624-5505 Fax #: (905) 238-2360 Web: www.panasonic.ca

For product repairs, please contact one of the following:

- Your Dealer who will inform you of an authorized Servicentre nearest you.
- Our Customer Care Centre at (905) 624-5505 or www.panasonic.ca
- A Panasonic Factory Servicentre listed on warranty page.

RÉPARATION SOUS GARANTIE

Pour de l'aide sur le fonctionnement de l'appareil ou pour toute demande d'information, veuillez contacter votre détaillant ou notre service à la clientèle au:

N° de téléphone : (905) 624-5505

N° de télécopieur : (905) 238-2360

Site Internet : www.panasonic.ca

Pour la réparation des appareils, veuillez consulter:

- votre détaillant, lequel pourra vous renseigner sur le centre de service agréé le plus près de votre domicile ;
- notre service à la clientèle au (905) 624-5505 ou www.panasonic.ca;
- un de nos centres de service.

Quando necesita servicio

Si su aspiradora Panasonic necesita servicio, busque el Centro de Servicio Panasonic o un Centro de Servicio PASC autorizado más cercano bajo "Servicio de Electrodomésticos" en las páginas amarillas de la guía de teléfonos o llame gratis al 1-800-211-PANA (7262) para encontrar un centro de servicio conveniente. **No mande el producto a las Executive o Regional Sales Offices. No están equipadas para arreglar estos productos.**

Si manda el producto

Empaquete con cuidado en el cartón original si posible y mándelo prepagado y con seguro suficiente. Ponga una carta con sellos en la que describe su problema con el producto en el exterior del cartón. **No mande el producto a las Executive o Regional Sales Offices. No están equipadas para arreglar estos productos.**

PANAMEX COMPANY DIVISION OF PANASONIC CORPORATION OF NORTH AMERICA

One Panasonic Way
Secaucus, New Jersey 07094
World Wide Web Address
<http://www.panasonic.com>

PANASONIC CORPORATION OF NORTH AMERICA

One Panasonic Way Secaucus,
New Jersey 07094
World Wide Web Address
<http://www.panasonic.com>

PANASONIC SALES COMPANY, DIVISION OF PANASONIC PUERTO RICO, INC.

Ave. 65 de Infantería. Km.9.5 San Gabriel
Industrial Park Carolina, Puerto Rico 00985

PANASONIC CANADA INC.

5770 Ambler Drive Mississauga, Ontario
L4W 2T3

V01Z5L00U
S0808-0

Printed in P.R.C.
Imprimé à R.P.C.