

This Owner's Manual is provided and hosted by [Appliance Factory Parts](#).



PANASONIC MC-CG985 Owner's Manual

[Shop genuine replacement parts for PANASONIC
MC-CG985](#)



[Find Your PANASONIC Vacuum Cleaner Parts - Select From 605 Models](#)

----- Manual continues below -----

Panasonic®

VACUUM CLEANER

Aspirateur

Aspiradora

MC-CG985

Operating Instructions

Manuel d'utilisation

Instrucciones de operación

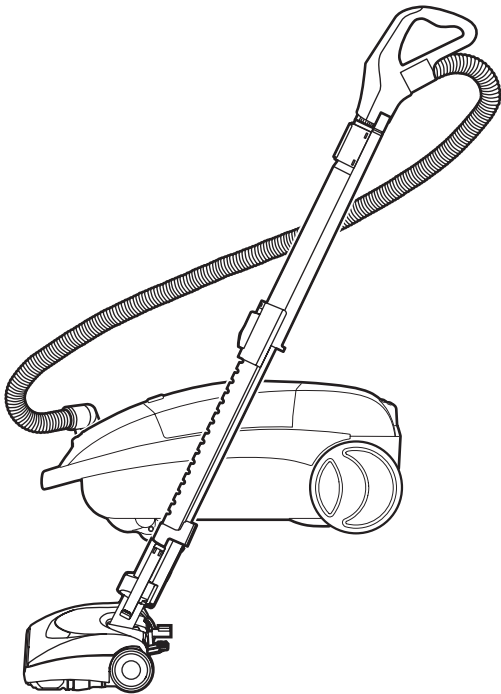

Before operating your vacuum cleaner, please read these instructions completely.

Avant d'utiliser l'appareil, il est recommandé de lire attentivement ce manuel.

Antes de usar su aspiradora, por favor lea completamente estas instrucciones.

CONSUMER INFORMATION

Please read **IMPORTANT SAFETY INSTRUCTIONS** on page 5 before use. Read and understand all instructions.

TO OUR VALUED CUSTOMER

We are very pleased to welcome you to the Panasonic family of products. Thank you for purchasing this product. Our intent is that you become one of our many satisfied customers.

Proper assembly and safe use of your vacuum cleaner are your responsibilities. Your vacuum cleaner is intended only for household use. The vacuum cleaner should be stored in a dry, indoor area. Read the Operating Instructions carefully for important use and safety information.

Special care is required when vacuuming certain types of carpet or floor covering. Always check the carpet or floor covering manufacturer's recommended cleaning instructions before vacuuming.

PLEASE PAY CLOSE ATTENTION TO ALL WARNING AND CAUTION STATEMENTS.

WARNING

WARNING statements are designed to alert you to the possibility of personal injury, loss of human life, and/or damage to the vacuum cleaner and/or personal property if the instructions given are not followed.

CAUTION

CAUTION statements are designed to alert you to the possibility of damage to the vacuum cleaner and/or personal property if the instructions given are not followed.

WARNING

TO AVOID ELECTRICAL SHOCK

Never vacuum damp or wet surfaces or liquids.
DO NOT store vacuum cleaner outdoors.
Replace worn or frayed power cord immediately.
Unplug from outlet when not in use and before servicing.

TO AVOID ACCIDENTS

Except for hand-held cleaners, keep vacuum cleaner on floor - not chairs, tables, steps, stairs, etc.
Store vacuum cleaner promptly after each use to prevent accidents such as tripping over power cord or vacuum cleaner.
Use vacuum cleaner and accessories only in a manner intended by the manufacturer.
The use of an extension cord is not recommended.

© 2008 Panasonic Home Appliances Company of North America,
Division of Panasonic Corporation of North America. All rights reserved.

IMPORTANT SAFETY INSTRUCTIONS

When using your vacuum cleaner, basic precautions should always be followed, including the following:

Read all instructions in this manual before assembling or using your vacuum cleaner.

WARNING To reduce the risk of fire, electrical shock, injury:

1. **DO NOT** leave vacuum cleaner plugged in when not in use. Unplug from outlet when not in use and before servicing.
2. To reduce the risk of fire, or electric shock - **DO NOT** use outdoors or on wet surfaces.
3. **DO NOT** allow to be used as a toy. Close attention is necessary when used by or near children.
4. Use only as described in this manual. Use only manufacturer's recommended attachments.
5. **DO NOT** use with damaged cord or plug. If vacuum cleaner is not working as it should, or if it has been dropped, damaged, left outdoors, or dropped into water, return it to an Authorized Panasonic Service Center.
6. **DO NOT** pull or carry by cord, use cord as a handle, close door on cord, or pull cord around sharp edges or corners. Do not run vacuum cleaner over cord. Keep cord away from heated surfaces.
7. Hold plug when rewinding onto cord reel. **DO NOT** allow plug to whip when rewinding.
8. **DO NOT** unplug by pulling on cord. To unplug, grasp the plug, not the cord.
9. **DO NOT** handle plug or vacuum cleaner with wet hands.
10. **DO NOT** put any objects into openings. **DO NOT** use with any opening blocked; keep free of dust, lint, hair, and anything that may reduce air flow.
11. Keep hair, loose clothing, fingers, and all parts of body away from openings and moving parts.
12. **DO NOT** pick up anything that is burning or smoking, such as cigarettes, matches, or hot ashes.
13. **DO NOT** use without dust bag and/or filters in place.
14. Turn off all controls before unplugging.
15. Use extra care when cleaning on stairs.
16. **DO NOT** use vacuum cleaner to pick up flammable or combustible liquids such as gasoline or use in areas where they may be present.
17. **DO NOT** operate vacuum cleaner with punctured hose. The hose contains electrical wires. Replace if cut or worn. Avoid picking up sharp objects.
18. Always turn off vacuum cleaner before connecting or disconnecting the hose or Power Nozzle.

SAVE THESE INSTRUCTIONS THIS VACUUM CLEANER IS INTENDED FOR HOUSEHOLD USE ONLY

Note: Before you plug in your Panasonic vacuum cleaner, make sure that the voltage indicated on the rating plate located at the back of the vacuum cleaner is the same as your local supply.

TABLE OF CONTENTS

CONSUMER INFORMATION	2
IMPORTANT SAFETY INSTRUCTIONS	5
PARTS IDENTIFICATION	10-12
FEATURE CHART	13
ASSEMBLY	14
Power Nozzle	14
Canister	14
Hood	14
Hose	16
Tool Storage	16
Compact Power Nozzle and Caddy	18
TO OPERATE VACUUM CLEANER	20
Power Cord	20
Electronic Touch Control	22
Telescopic Wand Adjustments	24
Handle Adjustments	24
Suggested Pile Height Settings	24
Using Tools	26-28
Vacuuming Tips	30
FEATURES	32
Overload Protector	32
Electronic Hose/Bag Check Indicator	32
Suction Control	32
Hose Swivel	34
Edge Cleaner	34
Thermal Protector	34
Dirt Sensor	36
ROUTINE CARE OF VACUUM CLEANER	38
Changing Dust Bag	38
Motor Safety Filter Changing	40
Exhaust Filter Changing	42
Cleaning Exterior and Tools	44
POWER NOZZLE CARE	44
Dirt Sensor	46
Removing Belt	48
Replacing Belt	50
Brush Servicing	52
Replacing Headlight Bulb	54
Removing Clogs	54
BEFORE REQUESTING SERVICE	56
WARRANTY	59,60
NOTES	63
WHAT TO DO WHEN SERVICE IS NEEDED	64

PARTS IDENTIFICATION

Nomenclature

Identificación de piezas

Power Nozzle

Tête motorisée

Power Nozzle

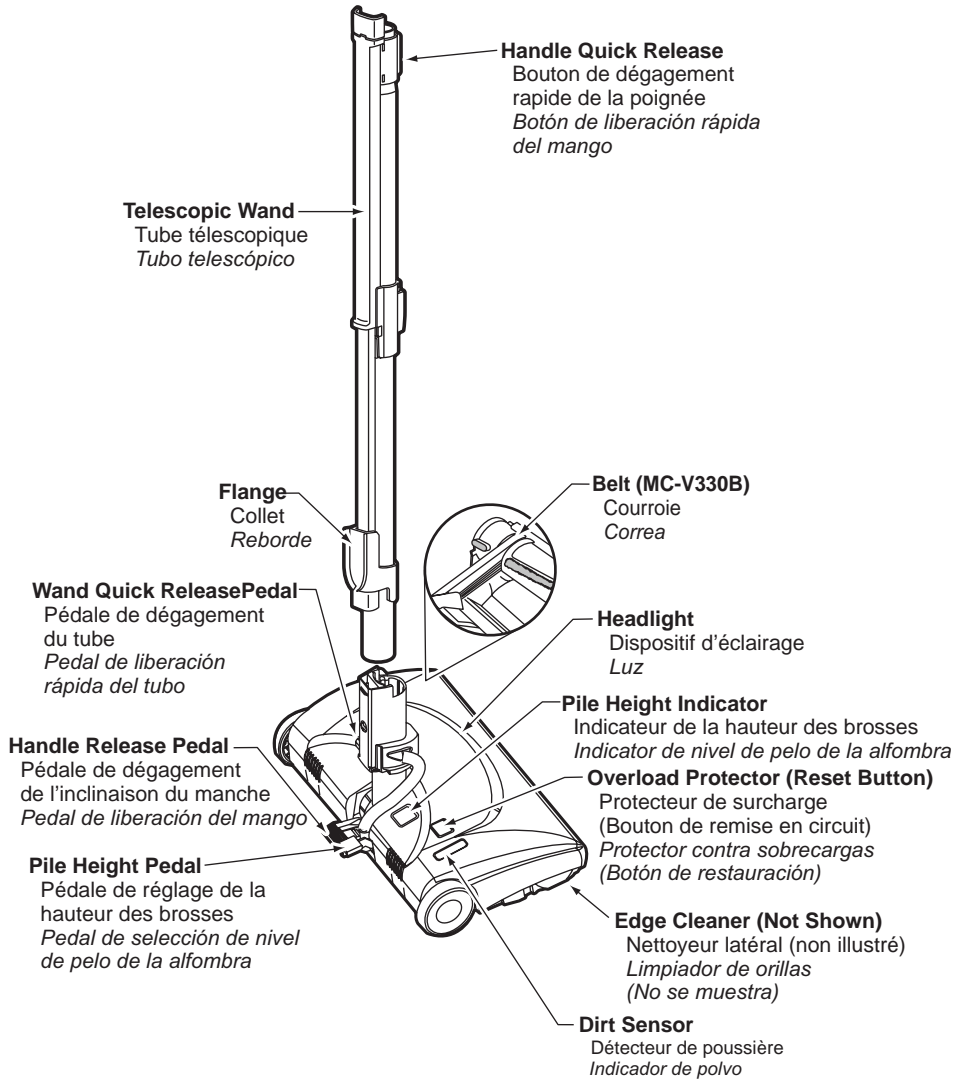

PARTS IDENTIFICATION
Nomenclature
Identificación de piezas

Canister
Chariot
Recepticulo

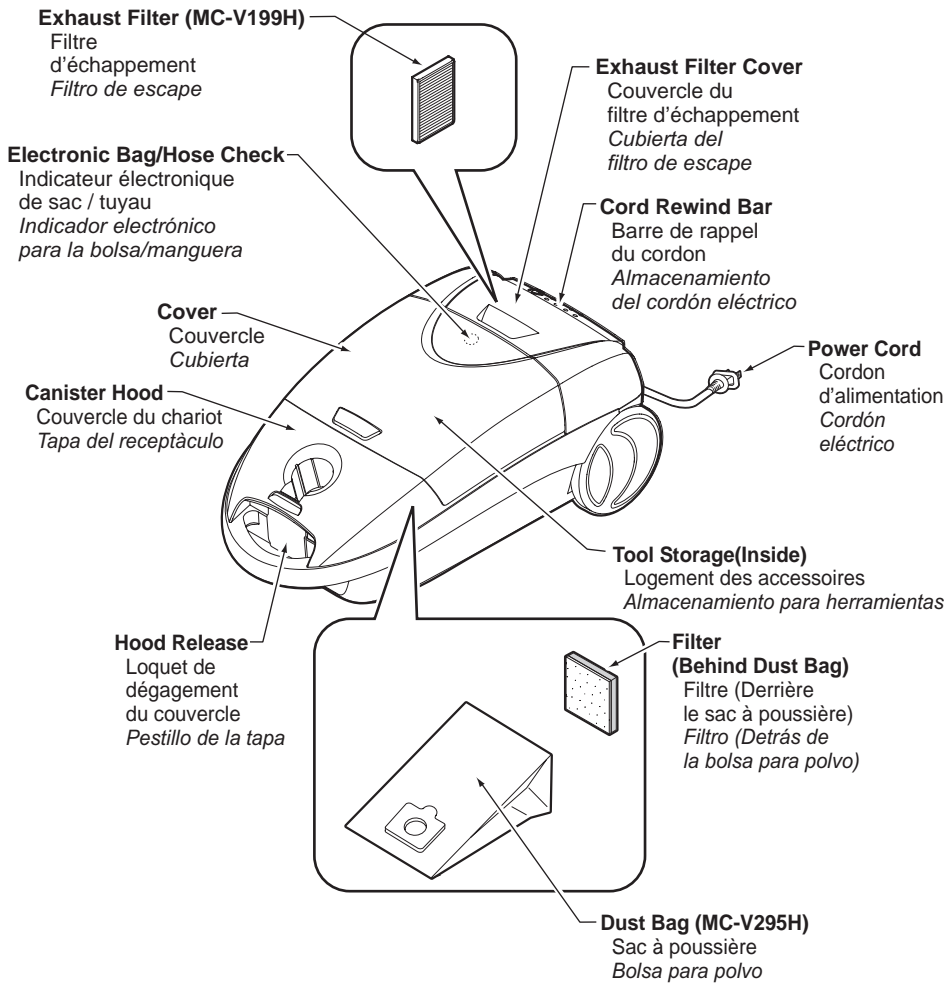

PARTS IDENTIFICATION
Nomenclature
Identificación de piezas

Hose
Tuyau
Manguera

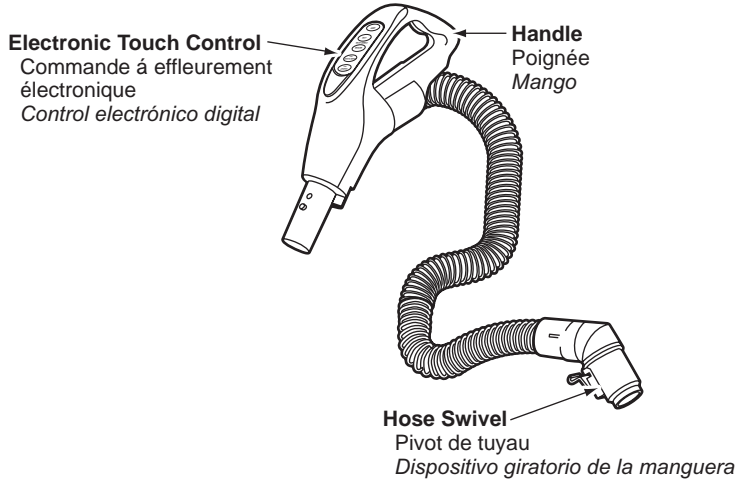

Tools
Accessoires
Herramientas

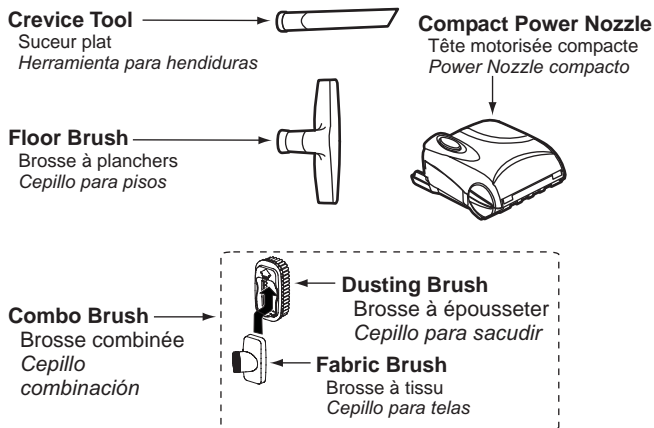

FEATURE CHART

POWER	Overload Protector	Headlight	Tools-On-Board	Cord Length	Dirt Sensor
120V. AC (60Hz) 12.0 A	Yes	Yes	Yes	28 Ft. (8.5 m)	Yes

Tableau des caractéristiques

Alimentation	Protecteur de surcharge	Dispositif d'éclairage	Accessoires	Longueur du cordon	Détecteur de poussière
120 V c.a. (60 Hz) 12,0 A	Oui	Oui	Oui	8,5 m (28 pi)	Oui

Diagrama de características

<i>Voltaje</i>	<i>Protector contra subrecargas</i>	<i>Luz</i>	<i>Herramientas</i>	<i>Extensión de cordón</i>	<i>Detector de tierra</i>
120V. AC (60Hz) 12,0 A	Si	Si	Si	8,5 m (28 pi)	Si

ASSEMBLY

Power Nozzle

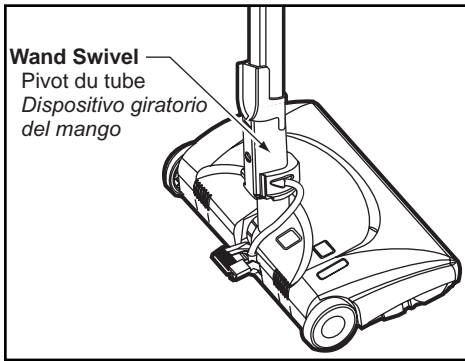

- Insert wand into **POWER NOZZLE** until the wand button snaps into place.

TO REMOVE:

- Press wand quick release pedal.
- Pull wand out of **POWER NOZZLE**.

Canister

- Open canister hood.
- Check dust bag (See **CHANGING DUST BAG** for instructions).
- Check filter (See **MOTOR SAFETY FILTER CHANGING** for instructions).

Hood

- It is normal for the canister hood to come off when it is opened further than needed.
- Line up the hinges, insert them, and close the hood to replace it.

Hose

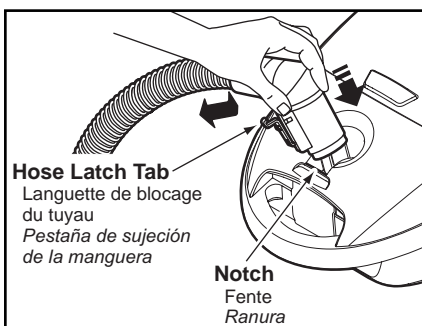

- Line up the hose latch tab and notch in canister hood and insert hose into canister until it snaps in place.

To Remove:

- Lift hose latch tab upward and pull up on hose.

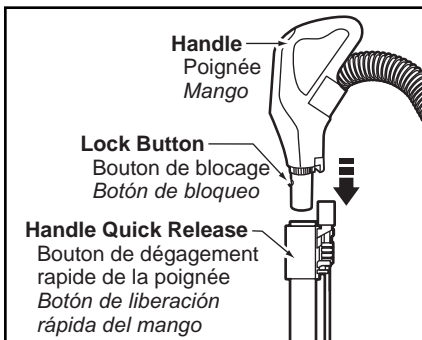

- Insert handle into wand until lock button snaps in place.

- Be sure the hose is not twisted.

To Remove:

- Press handle quick release and pull up on handle.

Tool Storage

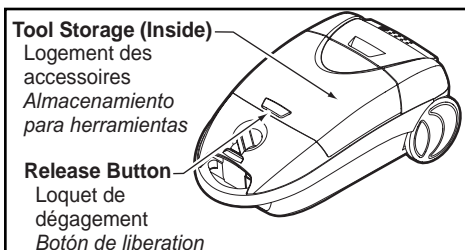

- Tools are stored on-board the vacuum cleaner in the tool storage area.

- To open, press cover release button on the tool storage cover.

- Open cover to access tools as needed (See USING TOOLS).

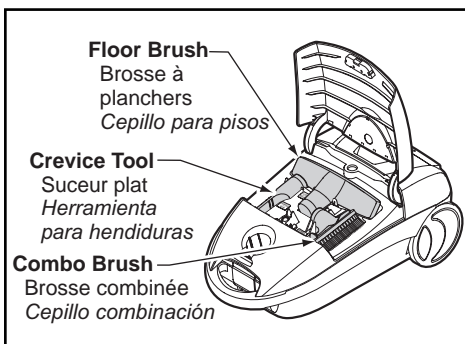

Compact Power Nozzle and Caddy

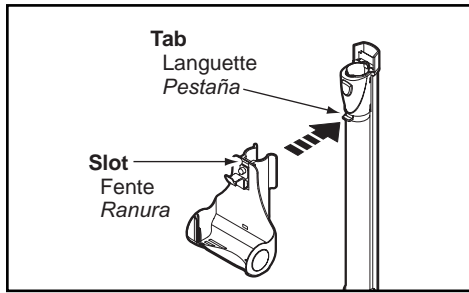

TO ATTACH CADDY

- Align the tab on the wand with the slot in the caddy.
- Press the caddy onto the upper wand. The caddy will snap into place

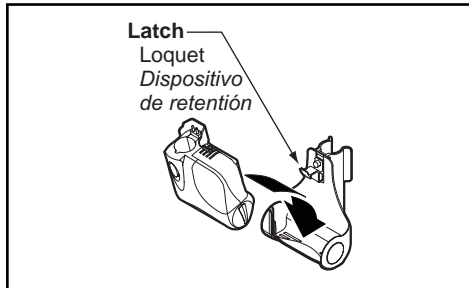

TO INSERT COMPACT POWER NOZZLE

- Place the front of the Compact Power Nozzle into the caddy.
- Rotate the Compact Power Nozzle back until it snaps into place.

TO REMOVE COMPACT POWER NOZZLE

- Press the latch and lift the Compact Power Nozzle out of the caddy.

TO OPERATE VACUUM CLEANER

Power Cord

NOTE: To reduce the risk of electrical shock, this vacuum cleaner has a polarized plug - one blade is wider than the other. This plug will fit in a polarized outlet only one way. If the plug does not fit fully in the outlet, reverse the plug. If it still does not fit, contact a qualified electrician to install the proper outlet. **DO NOT CHANGE THE PLUG IN ANY WAY.** Only use outlets near the floor.



- Pull cord out of canister to desired length.
- Cord will not rewind until cord rewind button is pushed.

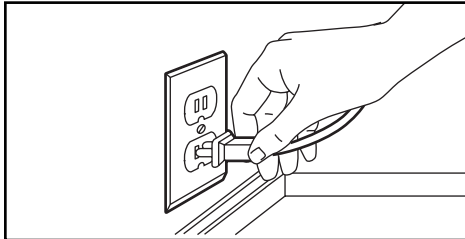

- Plug cord into 120-volt outlet located near the floor.

TO REWIND:

- Unplug the vacuum cleaner.
- Hold the plug while rewinding to prevent damage or injury from the moving cord.
- Push cord rewind bar.

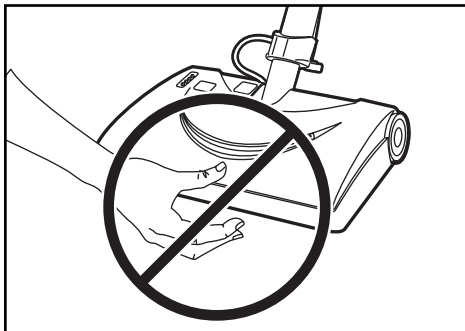
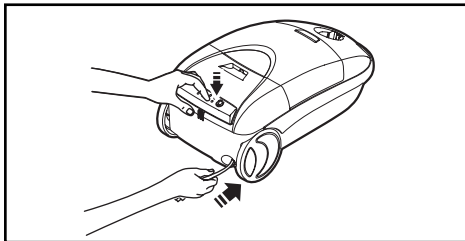

! CAUTION

Moving parts! To reduce the risk of personal injury, **DO NOT** touch the agitator when vacuum cleaner is on. Contacting the agitator while it is rotating can cut, bruise or cause other injuries. Always unplug from electrical outlet before servicing. Use caution when operating near children.

Electronic Touch Control

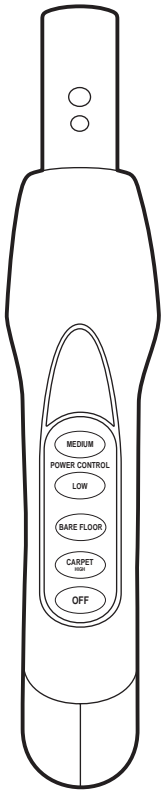

- Select an Electronic Touch Control position on the handle depending on the type of vacuuming you will be doing:
- **CARPET HIGH** - turns on both the canister and the **POWER NOZZLE** motors for **HIGH** power and cleaning of most carpets.
- In order to get **MEDIUM** or **LOW** power level for carpet cleaning, you must press **CARPET HIGH** button first, then press the desired lower power level.
- **BARE FLOOR** - turns on the canister motor only for **HIGH** power and cleaning of bare floors.
- **Power Level MEDIUM** - reduces the power of the canister motor only to the **MEDIUM** level for attachment cleaning of upholstery.
- **Power Level LOW** - reduces the power of the canister motor only to the **LOW** level for attachment cleaning of curtains, blinds, etc.
- **OFF** - turns off canister and **POWER NOZZLE** motors

NOTE - When the **BARE FLOOR** button is pressed, the headlight, wand light and dirt sensor **DO NOT** function since no electricity flows to the **POWER NOZZLE**

Commande à effleurement
électronique

- Sélectionner une position de Commande à effleurement électronique sur le manche, selon le type de nettoyage prévu.

- **CARPET HIGH (Niveau de puissance élevée pour MOQUETTE)** - met en marche les moteurs du réservoir et du POWER NOZZLE pour une haute puissance et la capacité de nettoyage de la plupart des moquettes.

- Afin d'obtenir un niveau de puissance **MEDIUM (MOYEN)** ou **LOW (BAS)**, pour le nettoyage des moquettes, il faut d'abord appuyer sur le bouton Niveau de puissance élevée pour **CARPET HIGH (MOQUETTE)**, puis sélectionner le niveau de puissance désirée.

- **BARE FLOOR (Niveau de puissance élevée pour PLANCHER NU)** - met en marche le moteur du réservoir seulement, pour une haute puissance et le nettoyage des planchers nus.

- **Power Level MEDIUM (Niveau de puissance MOYEN)** - réduit la puissance du moteur du réservoir au niveau moyen pour le nettoyage de meubles rembourrés utilisant les accessoires.

- **Power Level LOW (Niveau de puissance BAS)** - réduit la puissance du moteur du réservoir au niveau bas pour le nettoyage de rideaux, stores, etc.

- **OFF (ARRÊT)** - pour arrêter les moteurs du réservoir et POWER NOZZLE.

REMARQUE : Lorsque le bouton de niveau de puissance élevée **BARE FLOOR (PLANCHER NU)** est appuyé, le phare et le détecteur de poussière NE fonctionnent PAS, puisqu'il n'y a pas de débit d'électricité au POWER NOZZLE.

Control Electrónico Digital

- *Seleccione una posición de Control Electrónico Digital en el mango de acuerdo al tipo de aspirado que desee realizar:*

- *CARPET HIGH (ALFOMBRA ALTO) - enciende los motores del contenedor y de la POWER NOZZLE para obtener alto poder de limpieza para la mayoría de alfombras.*

- Para obtener nivel de poder **MEDIUM** o **LOW (MEDIO o BAJO)** para limpieza de alfombras, apriete el botón de **CARPET HIGH (ALFOMBRA ALTO)** primero, y en seguida apriete el nivel deseado de poder más bajo.

- *BARE FLOOR (PISO RASO) - enciende el motor del contenedor únicamente para poder HIGH (ALTO) y limpieza de pisos rasos (sin alfombras).*

- *Nivel de poder MEDIUM (MEDIO) - reduce la fuerza del motor del contenedor sólo al nivel MEDIUM (MEDIO) para limpieza, con accesorios, de tapicería.*

- *Nivel de poder LOW (BAJO) - reduce la fuerza del motor del contenedor exclusivamente al nivel LOW (BAJO) para limpieza con accesorios de cortinas, persianas, etc.*

- *OFF (APAGADO) - apaga los motores del contenedor y de la POWER NOZZLE.*

- *NOTA - Cuando el botón de BARE FLOOR (PISO RASO) está apretado, el farol, la luz del tubo y el indicador de polvo no funcionan porque la electricidad no fluye al POWER NOZZLE.*

Telescopic Wand Adjustments

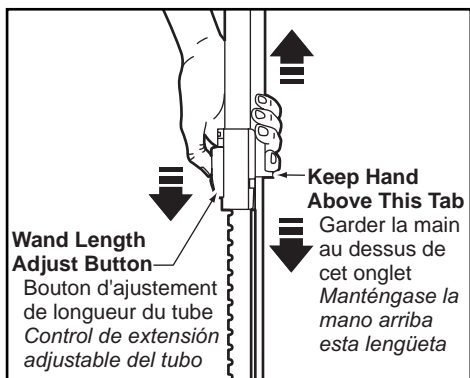

- The wand length is adjustable and requires no assembly.
- To adjust, simply push down on the wand adjust button and slide the upper wand to the desired height.
- When adjusting the wand length you may have to hold the **POWER NOZZLE** with your hand or foot.

Handle Adjustments

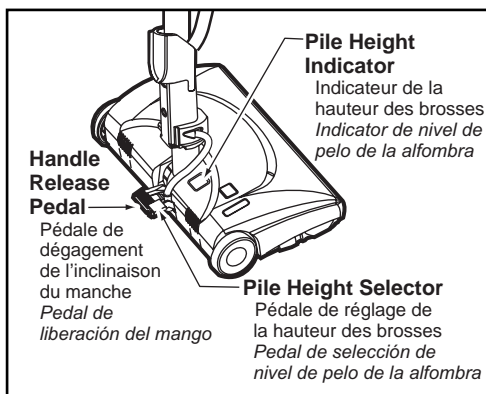

- Lower wand from upright position by pressing on the handle release pedal.
- Select a pile height setting by pressing the small pedal on the rear. The pile height setting is shown in the window.
- Return wands to upright position for storage.

Suggested Pile Height Settings

For best deep down cleaning, use the "XLO" setting. However, you may need to raise the height to make some jobs easier, (such as throw rugs and some deep pile carpets) and to prevent the vacuum cleaner from shutting off. Suggested settings are: "XLO" - most carpets and bare floors. "LO" - low to medium pile. "MED" - medium to deep pile. "HI" - shag; deep pile; scatter rugs.

Using Tools

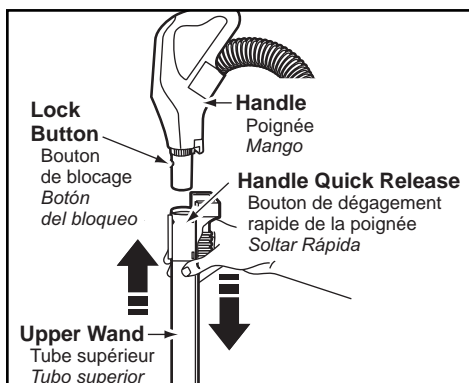

CAUTION

DO NOT attach or remove handle or wands while vacuum cleaner is **ON**. This could cause sparking and damage the electrical contacts.

ATTACHMENTS ON HANDLE

- If the **POWER NOZZLE** is attached, turn vacuum cleaner off before removing handle from wands.
- Press lock button, then pull to remove handle from wand.
- Slide attachments firmly on handle as needed (See page 30).

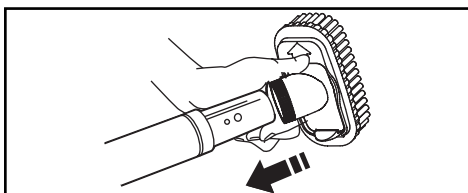

ATTACHMENTS ON WANDS

- If the **POWER NOZZLE** is attached, turn vacuum cleaner off before removing plug from wands.
- To remove wands from **POWER NOZZLE**, lock wands in upright position.
- Press wand quick release pedal with foot and pull the wands straight up out of **POWER NOZZLE**.
- Put attachments on wands as needed (See page 30).

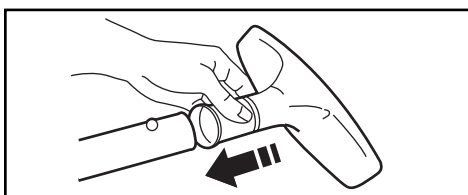
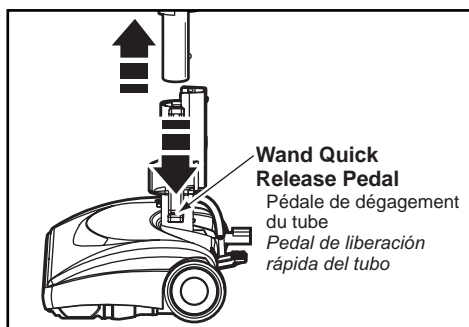
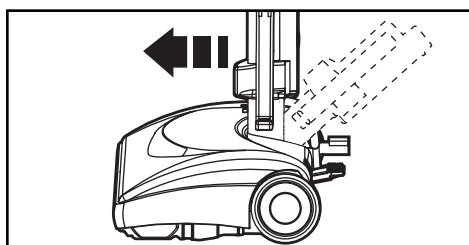

Using Tools

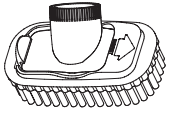

- The Combination Brush may be used on the following items:
 - Furniture
 - Drapes
 - Stairs
 - Walls



- The Crevice Tool may be used on the following items:
 - Furniture
 - Cushions
 - Drapes
 - Stairs
 - Walls

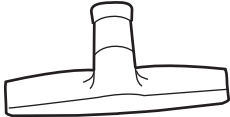

- The Floor Brush may be used on the following items:
 - Stairs
 - Bare Floors
 - Walls

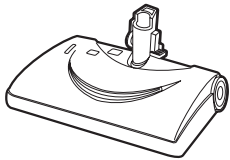

- The Power Nozzle may be used on the following items:
 - Carpeted Floors
 - Rugs



- The Compact Power Nozzle may be used on the following items:
 - Furniture
 - Stairs

Note: Always clean tools before using.

NOTE: When separating wands, depress lock button completely before pulling wands apart. If wand lock button is difficult to depress, push the two wands more tightly together to line up the lock button with the hole. Depress lock button and then pull wands apart.

Vacuuming Tips



Suggested sweeping pattern

For best cleaning action, the **POWER NOZZLE** should be pushed straight away from you and pulled straight back. At the end of each pull stroke, the direction of the **POWER NOZZLE** should be changed to point into the next section to be cleaned. This pattern should be continued across the rug with slow, gliding motions.

- Fast, jerky motions do not provide complete cleaning.
- Small areas can be cleaned without moving the canister.
- Carpeted stairs need to be vacuumed regularly.
- For best cleaning results, fully close the suction control.

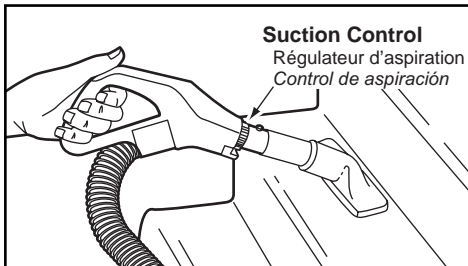

FEATURES

Overload Protector

Overload Protector (Reset Button)

Protecteur de surcharge
(Bouton de remise en circuit)
Protector contra sobrecargas
(Botón de restauración)



- The overload protector stops the **POWER NOZZLE** motor when the brush jams and prevents belt breakage.

NOTE: Canister motor will continue to run.

TO CORRECT PROBLEM:

- Unplug electrical cord.
- Check brush and brush support areas for excessive lint build-up or jamming.

- Clean jammed area.

TO RESET:

- Press reset button on top of the **POWER NOZZLE**. Plug in and turn on vacuum cleaner.

Electronic Hose/Bag Check Indicator

Electronic Bag/Hose Check Indicator

Indicateur électronique
de sac / tuyau
Indicador electrónico
para la bolsa/
manguera

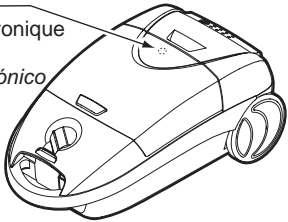

- The light comes on whenever the airflow becomes blocked, dust bag needs changing or canister safety filter needs cleaning.
- The light may come on when using certain attachments, due to reduced airflow through attachment.
- See **REMOVING CLOGS**.

Suction Control

Decrease Suction

Diminution
de l'aspiration
*Diminuir
aspiración*



Increase Suction

Augmentation
de l'aspiration
*Aumentar
aspiración*

- Suction control allows you to change vacuum cleaner suction for different fabric and carpet weight.
- Opening control decreases suction for draperies and lightweight rugs.
- Closing control increases suction for upholstery and carpets.

Hose Swivel

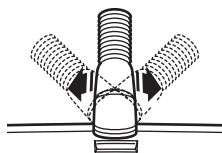

- The hose swivel allows the hose to turn without moving the canister. This is helpful for cleaning in small areas.
- Check hose for twisting before pulling canister.

Edge Cleaner

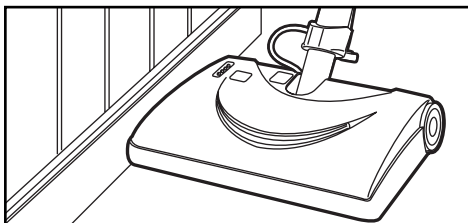

- Active brush edge cleaners are on both sides of the Power Nozzle.
- Guide either side of the Power Nozzle along base-boards or next to furniture to help remove dirt trapped at carpet edges.

Thermal Protector

- If a clog prevents the normal flow of air to the motor, the thermal protector turns the motor off automatically to allow the motor to cool in order to prevent possible damage to the vacuum cleaner.
- During this time the headlight remains on.
- To correct problem, turn off and unplug vacuum cleaner, remove clogs, and/or clean/replace filters.
- Replace full bag if necessary.
- Wait approximately thirty (30) minutes, plug vacuum cleaner in, turn on to see if thermal protector has reset. Thermal protector will not reset if vacuum cleaner is not turned off even if vacuum cleaner cools down.

Dirt Sensor

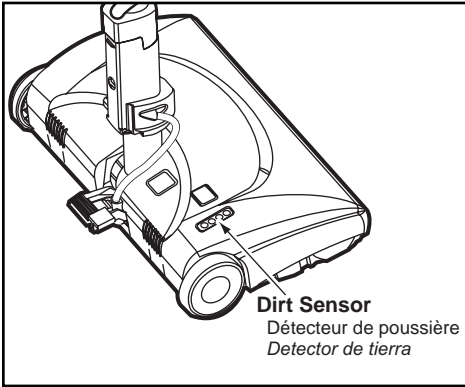

- The dirt sensor light system is mounted on the POWER NOZZLE near the reset button. It consists of a series of three red lights and one green light.
- The lights give you an indication of the amount of dirt particles that are passing through the sensor on its way to the dust bag.

INITIAL START UP

- When the POWER NOZZLE is first started, the following light sequence occurs in a two second time frame:
 1. All three reds come on.
 2. Two reds are on.
 3. One red is on.
 4. One green is on and will remain on until the POWER NOZZLE is placed in use.

NOTE: If the nozzle is on a surface that has dirt on it, dirt will be picked up by the vacuum and one or more red lights might stay on.

IN OPERATION

- When the POWER NOZZLE is being moved back and forth on the floor, the lights will change from one configuration to another as more dirt or less dirt is being vacuumed.
- As long as one or more red lights are on, dirt is passing through the wand to indicate that the surface still needs cleaning.
- When the green light stays on as the POWER NOZZLE is moved back and forth over an area, the sensor is not seeing enough dirt to warrant further cleaning of that area.

NOTE: Dirt sensor lights DO NOT function in the FLOOR setting.

ROUTINE CARE OF VACUUM CLEANER

Changing Dust Bag

Always operate vacuum cleaner with genuine Panasonic micron dust bag type C-19 installed. Panasonic dust bags may be purchased through any authorized Panasonic dealer or ordered from service company.

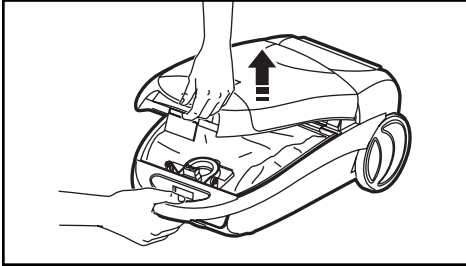

- Unplug cord from wall outlet.
- Pull hood release out and up, then lift canister hood.

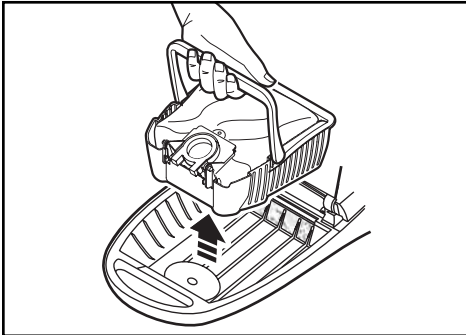

- Lift bag caddy out of canister.
- Remove cardboard tab from red bag mount by pressing away and lifting up.
- Pull bag out of the red bag mount.
- Raise red bag mount up.

Note:

Creasing the cardboard will cause it not to lock in place and dirt may not all go into the bag (some will miss the bag and end up in the bag cavity.)

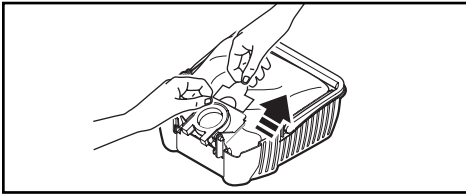

- Install bag into slots by pushing down until the cardboard tab locks into position and the holes align.

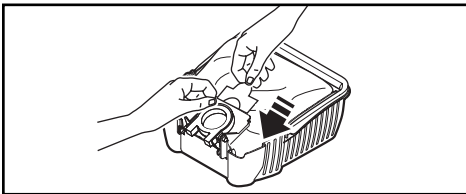

- Insert bag caddy into canister.
- Close and latch canister hood.
- Plug cord into wall outlet.

- **NEVER REUSE A DUST BAG.**

Motor Safety Filter Changing

- Check motor safety filter occasionally and change when dirty.

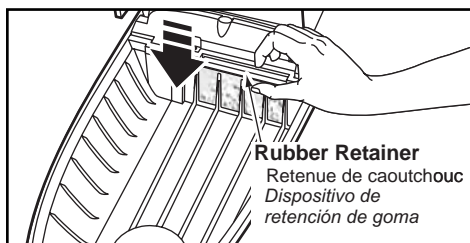

WARNING

Electrical Shock Hazard

Do not operate the vacuum cleaner without the motor safety filter. Be sure the filter is dry and properly installed to prevent motor failure and/or electrical shock.

- Unplug cord from wall outlet.
- Lift rubber retainer and pull out motor safety filter as shown.
- Replace filter.
- White side is mounted facing the dust bag.
- Filter cannot be cleaned and should be replaced at least once a year.
- Insert bag.
- **DO NOT CLEAN FILTER WITH WATER.**
- **DO NOT** operate the vacuum cleaner without filter.

Exhaust Filter Changing

WARNING

Fire and/or Electrical Shock Hazard
Do not operate with a clogged exhaust filter or without the exhaust filter or exhaust filter cover installed.

EXHAUST FILTER HEPA

- The exhaust filter cartridge must be replaced when dirty.
 - Replace the filter when the entire surface area is covered evenly.
 - The filter **CANNOT** be washed as it will lose its dust trapping ability.
-
- Pull up on the exhaust filter cover.
 - Grasp the exhaust filter and pull out to remove.
 - Replace the exhaust filter cartridge, carefully positioning it so that the airflow direction indicated on the filter cartridge matches the direction indicated on the vacuum cleaner.
 - Close the exhaust filter cover until it snaps into place.

Exhaust Filter Cover
Couvercle du
filtre d'échappement
Cubierta del
filtro de escape

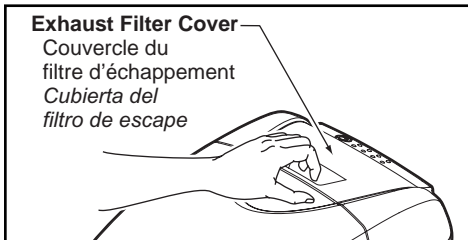

Exhaust Filter
Filtre
d'échappement
Filtro de escape

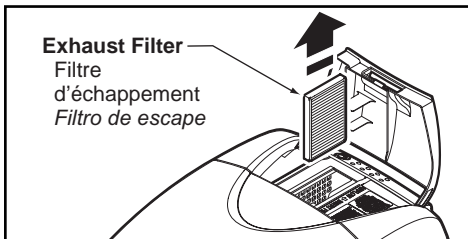

Exhaust Filter
Filtre
d'échappement
Filtro de escape

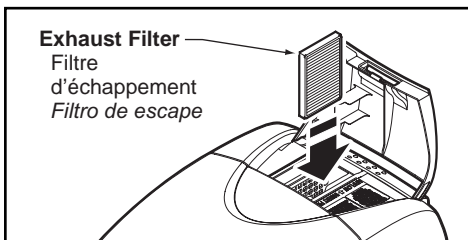

Cleaning Exterior and Tools

- Unplug cord from wall outlet.
- Clean exterior using a clean, soft cloth that has been dipped in a solution of mild liquid detergent and water and wrung dry.
- DO NOT drip water on vacuum cleaner. Wipe dry after cleaning.
- DO NOT clean tools in dishwasher or clothes washer.
- Wash tools in warm soapy water, rinse and air dry.
- DO NOT use tools if they are wet.

POWER NOZZLE CARE

Always follow all safety precautions before performing maintenance to the POWER NOZZLE.

WARNING

Electrical Shock or Personal Injury Hazard.

Disconnect the electrical supply before performing maintenance to the vacuum cleaner. Failure to do so could result in electrical shock or personal injury from vacuum cleaner suddenly starting.

Dirt Sensor

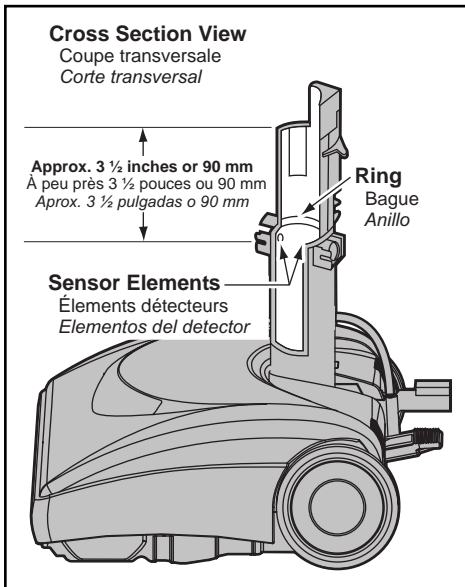
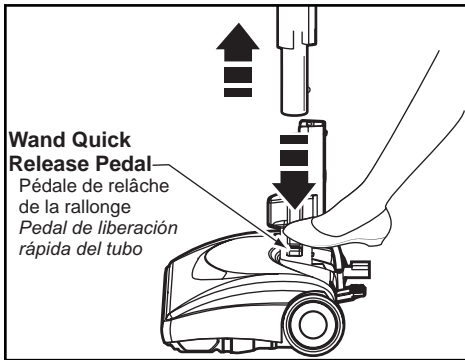

Although the dirt sensor feature in your POWER NOZZLE is designed for years of trouble free use, the passage of dirt through the air passage system can coat the lenses causing the green light to come on and stay on - never switching to red. When this happens the lenses must be cleaned.

CAUTION

Never use water or any cleaning solution when cleaning the lenses. The residue of the water or cleaners will accelerate the recoating of the lenses and make cleaning necessary sooner.

TO CLEAN THE LENSES

- Remove the wand by pressing the quick release pedal and lifting up on the wand.
- As indicated by the illustration, the two dirt sensor elements are located on the inside of the swivel, approximately 3 1/2 inches/90 mm down, (note the arrows). Each element should be cleaned periodically. To reach the sensor elements, use a small brush such as a bottle brush. Brush each sensor element several times to remove dust and dirt.

NOTE: Looking down inside the swivel you will see a ring. The sensor elements are located just slightly below this ring.

- Reinstall the wand after cleaning the sensors.

Removing Belt

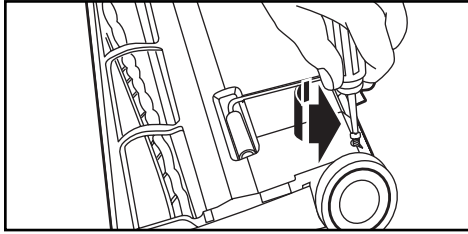

- Disconnect vacuum cleaner from electrical outlet.
- Check and remove hair, string and lint build-up frequently in the POWER NOZZLE brush and brush support areas.

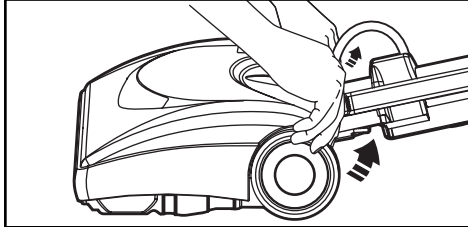

- If build-up becomes excessive, disconnect POWER NOZZLE from wand and follow the steps below.

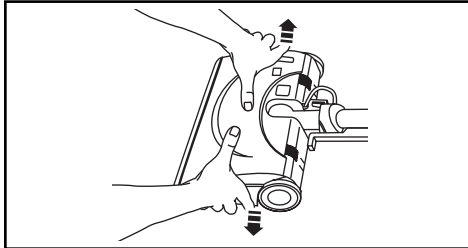

- Turn POWER NOZZLE over.
- Unscrew the two (2) POWER NOZZLE cover screws.
- Turn POWER NOZZLE right side up.
- Press handle release pedal and lower the swivel.

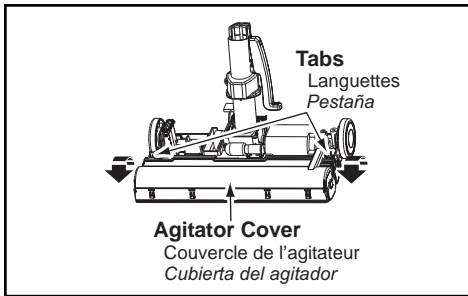

- To remove cover, grasp the sides and pull out.
- Tilt cover forward from back until front snaps free.
- Depress tabs on rear of agitator cover and rotate forward to release from the POWER NOZZLE base.

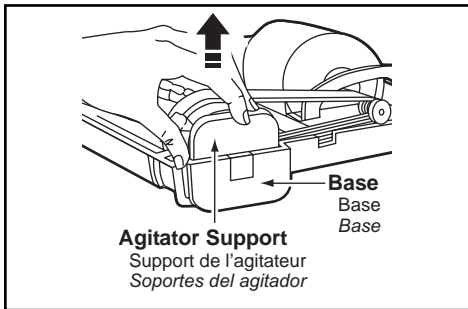

- Lift agitator assembly out .
- Remove worn belt.

Agitator Assembly

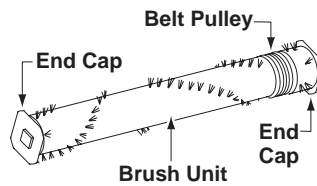

Replacing Belt

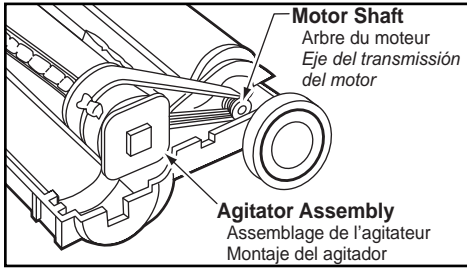

- Install new belt in belt groove on the agitator assembly, then over the motor shaft.
- Place agitator assembly back into POWER NOZZLE.
- Replace agitator cover.

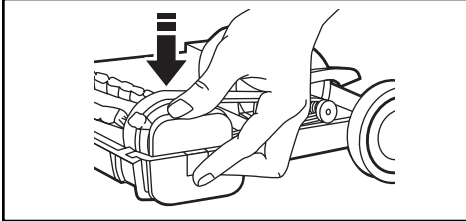

- Line up front of cover and base.
- Rest cover on front edge of base as shown.
- Tilt cover to back.
- Press cover firmly until tabs snap into place.
- Replace cover screws.

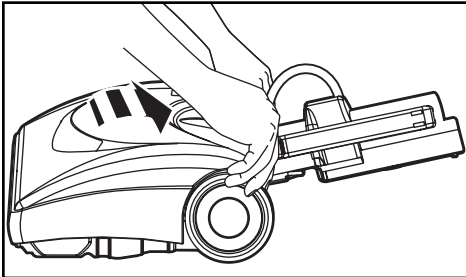
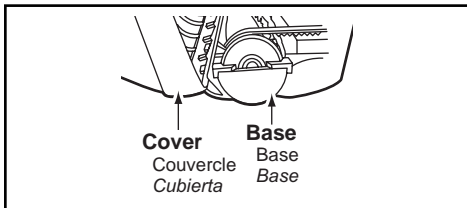
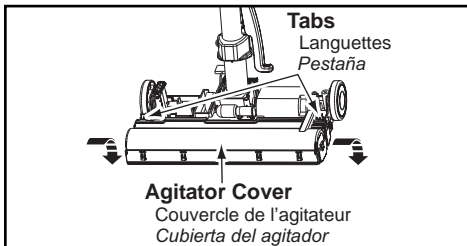

Brush Servicing

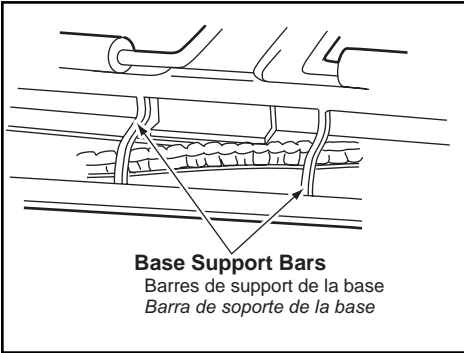

WARNING

Electrical Shock Or Personal Injury Hazard

Disconnect electrical supply before performing maintenance to the vacuum cleaner. Failure to do so could result in electrical shock or personal injury from vacuum cleaner suddenly starting.

TO CHECK BRUSHES:

- When brushes are worn to the level of the base support bar, replace the brush dowel.

TO REPLACE AGITATOR ASSEMBLY

- Remove **POWER NOZZLE** cover, agitator cover, belt and agitator assembly. (See “**REMOVING BELT**”).
- Replace agitator assembly.
- Replace belt, agitator cover, **POWER NOZZLE** cover and screws. (See “**REPLACING BELT**”).

Replacing Headlight Bulb

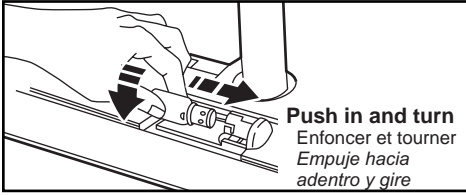
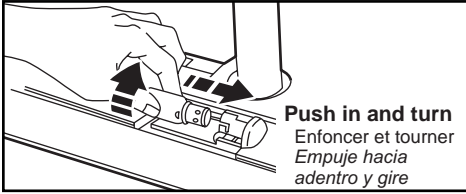

- Remove POWER NOZZLE cover.
- Push in and turn bulb counter-clockwise to remove.
- Replace the bulb.
- Only use a bulb rated 130 V AC-15 Watts.
- Replace POWER NOZZLE cover.

Removing Clogs

The vacuum cleaner creates suction that picks up dirt. Rapidly moving air carries the dirt to the dust bag through the air flow passage. The dust bag lets the air pass through, while it traps the dirt.

For best cleaning results, keep the airflow passage open. Check the starred areas occasionally for clogs. Unplug vacuum cleaner before checking airflow.

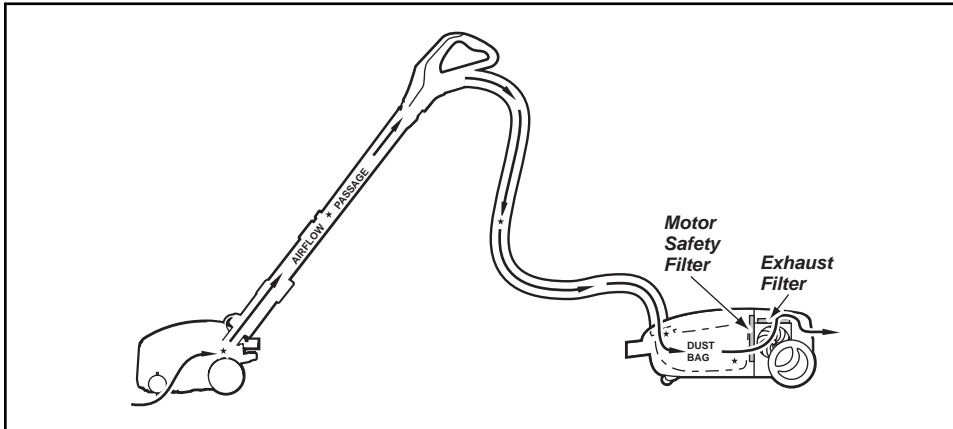

BEFORE REQUESTING SERVICE



WARNING *Electric Shock or Personal Injury Hazard.*

Disconnect the electrical supply before performing maintenance to the vacuum cleaner. Failure to do so could result in electric shock or personal injury from vacuum cleaner suddenly starting.

Review this chart to find do-it-yourself solutions for minor performance problems. Any service needed, other than those described in these Operating Instructions, should be performed by an authorized service representative.

PROBLEM	POSSIBLE CAUSE	POSSIBLE SOLUTION
Vacuum cleaner won't start.	<ol style="list-style-type: none"> 1. Unplugged at wall outlet. 2. Tripped circuit breaker/blown fuse at household service panel. 3. Loose hose electrical connections. 	<ol style="list-style-type: none"> 1. Plug in firmly, push ON/OFF switch to ON. 2. Reset circuit breaker or replace fuse. 3. Reconnect hose ends.
Poor job of dirt pick-up.	<ol style="list-style-type: none"> 1. Full or clogged dust bag. 2. Clogged airflow passages. 3. Dirty safety filter. 4. Wrong pile height setting. 5. Open suction control. 6. Hole in hose. 7. Worn POWER NOZZLE brushes. 8. Worn or broken belt. 9. Dirty agitator or end caps. 10. Canister hood open. 	<ol style="list-style-type: none"> 1. Change bag. 2. Clear airflow passages. 3. Replace filter. 4. Adjust setting. 5. Adjust control. 6. Replace hose. 7. Replace agitator. 8 & 9. See REMOVING BELT and REPLACING BELT. 10. Close and latch hood.
Vacuum cleaner starts but cuts off.	<ol style="list-style-type: none"> 1. Hose or hood electrical connections. 2. Tripped overload protector in POWER NOZZLE. 3. Tripped thermal protector in canister. 	<ol style="list-style-type: none"> 1. Check connections, reconnect hose ends. 2. Remove any items that may be caught or jammed, then reset. If vacuum cleaner starts and stops again, clean agitator and end caps, then reset. 3. Change dust bag, clear airflow blockage. Wait 30 minutes for motor to cool and automatically reset.
Power Nozzle will not run when attached.	<ol style="list-style-type: none"> 1. POWER NOZZLE connections unplugged. 2. Worn or broken belt. 3. Dirty agitator or end caps. 4. Tripped overload protector in POWER NOZZLE. 	<ol style="list-style-type: none"> 1. Plug in firmly. 2 & 3. See REMOVING BELT and REPLACING BELT. 4. Remove any items that may be caught or jammed, then reset. If vacuum cleaner starts and stops again, clean agitator and end caps, then reset.
Constant green light on in dirt sensor.	<ol style="list-style-type: none"> 1. Dirt passage is clogged. 2. Lenses are dirty. 	<ol style="list-style-type: none"> 1. Check for clogs in air passages. 2. Clean lenses.
Any, some, or all red lights in dirt sensor burn and never turn green.	<ol style="list-style-type: none"> 1. Dirt passage is clogged. 	<ol style="list-style-type: none"> 1. Check for clogs in air passages.
No green or red dirt sensor lights.	<ol style="list-style-type: none"> 1. Switch not in CARPET position. 2. No power to sensor board. 	<ol style="list-style-type: none"> 1. Move switch to CARPET position. 2. Take to your nearest Panasonic Servicenter.
Performance indicator is red.	<ol style="list-style-type: none"> 1. Full or clogged dust bag. 2. Dirty filter. 3. Clogged airflow passage. 4. Certain attachment tools. 	<ol style="list-style-type: none"> 1. Change bag. 2. Replace filter. 3. Clear clog from airflow passage. 4. This is normal. Light should go off when tool is removed.
Vacuum Cleaner picks up moveable rugs -or- Power Nozzle pushes too hard.	<ol style="list-style-type: none"> 1. Wrong pile height setting. 2. Suction too strong. 	<ol style="list-style-type: none"> 1. Adjust setting. 2. Open suction control.
Light won't work.	<ol style="list-style-type: none"> 1. Burned out light bulb. 	<ol style="list-style-type: none"> 1. Change light bulb.
Cord won't rewind.	<ol style="list-style-type: none"> 1. Dirty power cord. 2. Cord jammed. 	<ol style="list-style-type: none"> 1. Clean the power cord. 2. Pull out cord and rewind.
Vacuum cleaner leaves marks on carpet.	<ol style="list-style-type: none"> 1. Wrong vacuuming pattern. 	<ol style="list-style-type: none"> 1. See VACUUMING TIPS.

WARRANTY

Panasonic Platinum Series Vacuum Cleaner Limited Warranty

Panasonic Consumer Electronics Company (collectively referred to as "the warrantor") will repair this product, in the event of a defect in materials or workmanship, with new or refurbished parts free of charge, in the U.S.A. or Puerto Rico, for the length of the period indicated on the chart below, from the date of original purchase.

	<u>PARTS</u>	<u>LABOR</u>
All Parts (except motors)	Two (2) Years	Two (2) Years
Motors	Five (5) Years	Five (5) Years

This Limited Warranty Excludes both Labor and Parts for the following items which require normal replacement: Disposable Dust Bag, Filters, Belts, Light Bulbs, Agitator Brushes and Batteries (if supplied).

Carry-in or mail-in service in the U.S.A. can be obtained during the warranty period by calling 1-800-211-PANA (7262) to locate a PSTC authorized service center, or you can also visit our Web Site: <http://www.panasonic.com/consumersupport>.

Carry-in or mail-in service in Puerto Rico can be obtained during the warranty period by calling the local Panasonic Sales Company telephone number listed in the Service Center Directory.

This warranty is extended only to the original purchaser. A purchase receipt or other proof of date of original purchase will be required before warranty performance is rendered.

This warranty only covers failures due to defects in materials and workmanship which occur during normal use and does not cover damages which occur in shipment, or failures which are caused by products not supplied by the warrantor, or failures which result from accident, misuse, abuse, neglect, bug infestation, mishandling, misapplication, faulty installation, improper operation or maintenance, alteration, modification, power line surge, improper voltage supply, lightning damage, commercial use such as hotel, office, restaurant or other business or rental use of the product, or service by anyone other than a PSTC authorized service center, or damage that is attributable to acts of God.

LIMITS AND EXCLUSIONS:

There are no express warranties except as listed above.

THE WARRANTOR SHALL NOT BE LIABLE FOR INCIDENTAL OR CONSEQUENTIAL DAMAGES RESULTING FROM THE USE OF THIS PRODUCT, OR ARISING OUT OF ANY BREACH OF THIS WARRANTY. ALL EXPRESS AND IMPLIED WARRANTIES, INCLUDING THE WARRANTIES OF MERCHANTABILITY AND FITNESS FOR A PARTICULAR PURPOSE, ARE LIMITED TO THE APPLICABLE WARRANTY PERIOD SET FORTH ABOVE.

Some states do not allow the exclusion or limitation of incidental or consequential damages, or limitations on how long an implied warranty lasts, so the above exclusions or limitations may not apply to you.

This warranty gives you specific legal rights and you may also have other rights which vary from state to state. If a problem with this product develops during or after the warranty period, you may contact your dealer or service center. If the problem is not handled to your satisfaction, then write to the Consumer Affairs Department at the listed address on the back cover.

WARRANTY

Panasonic Canada Inc.
5770 Ambler Drive, Mississauga, Ontario L4W 2T3

Panasonic Vacuum Cleaner Limited Warranty

Panasonic Canada Inc. warrants this product to be free from defects in material and workmanship and agrees to remedy any such defect for a period as stated below from the date of original purchase.

Vacuum Cleaner - One (1) year, parts and labour

LIMITATIONS AND EXCLUSIONS

This warranty does not apply to products purchased outside Canada or to any product which has been improperly installed, subjected to usage for which the product was not designed, misused or abused, damaged during shipping, or which has been altered or repaired in any way that affects the reliability or detracts from the performance, nor does it cover any product which is used commercially. Parts such as disposable dust bags, filters, belts, light bulbs and agitator brushes are not covered by this warranty. Rechargeable batteries are warranted for ninety (90) days from date of original purchase.

This warranty is extended to the original end user purchaser only. A purchase receipt or other proof of date of original purchase is required before warranty service is performed.

THIS EXPRESS, LIMITED WARRANTY IS IN LIEU OF ALL OTHER WARRANTIES, EXPRESS OR IMPLIED, INCLUDING ANY IMPLIED WARRANTIES OF MERCHANTABILITY AND FITNESS FOR A PARTICULAR PURPOSE.

IN NO EVENT WILL PANASONIC CANADA INC. BE LIABLE FOR ANY SPECIAL, INDIRECT OR CONSEQUENTIAL DAMAGES.

In certain instances, some jurisdictions do not allow the exclusion or limitation of incidental or consequential damages, or the exclusion of implied warranties, so the above limitations and exclusions may not be applicable.

WARRANTY SERVICE

FOR PRODUCT OPERATION ASSISTANCE, please contact:

Our Customer Care Centre:	Telephone #:	(905) 624-5505
	1-800 #:	1-800-561-5505
	Fax #:	(905) 238-2360
	Email link:	"Contact Us" on www.panasonic.ca

FOR PRODUCT REPAIRS, please locate your nearest Authorized Servicentre at www.panasonic.ca :

Link : "ServicentresTM locator" under "Customer support"

IF YOU SHIP THE PRODUCT TO A SERVICENTRE

Carefully pack and send prepaid, adequately insured and preferably in the original carton.
Include details of the defect claimed, and proof of date of original purchase.

WHAT TO DO WHEN SERVICE IS NEEDED

If your Panasonic Vacuum Cleaner needs service, look in the yellow pages of the telephone book under HOME APPLIANCE SERVICE for your nearest Panasonic Services Company ("PASC") Factory Servicenter, or PASC authorized Servicenter, or call, 1-800-211-PANA (7262) toll free to find a convenient servicenter. **DO NOT send the product to the Executive or Regional Sales offices. They are NOT equipped to make repairs.**

If you ship the product

Carefully pack and send it prepaid, adequately insured and preferably in the original carton. Attach a postage-paid letter to the outside of the carton, which contains a description of your complaint. **DO NOT send the product to the Executive or Regional Sales Offices. They are NOT equipped to make repairs.**

PANASONIC CONSUMER ELECTRONICS COMPANY
DIVISION OF PANASONIC CORPORATION OF NORTH AMERICA

One Panasonic Way
Secaucus, New Jersey 07094
World Wide Web Address
<http://www.panasonic.com>

What to do when service is needed Service après-vente (Canada)

WARRANTY SERVICE

For product operation and information assistance, please contact your Dealer or our Customer Care Centre at:
Telephone #: (905) 624-5505 Fax #: (905) 238-2360 Web: www.panasonic.ca

For product repairs, please contact one of the following:

- Your Dealer who will inform you of an authorized Servicenter nearest you.
- Our Customer Care Centre at (905) 624-5505 or www.panasonic.ca
- A Panasonic Factory Servicenter listed on warranty page.

RÉPARATION SOUS GARANTIE

Pour de l'aide sur le fonctionnement de l'appareil ou pour toute demande d'information, veuillez contacter votre détaillant ou notre service à la clientèle au:

N° de téléphone : (905) 624-5505 N° de télécopieur : (905) 238-2360 Site Internet : www.panasonic.ca

Pour la réparation des appareils, veuillez consulter:

- votre détaillant, lequel pourra vous renseigner sur le centre de service agréé le plus près de votre domicile ;
- notre service à la clientèle au (905) 624-5505 ou www.panasonic.ca;
- un de nos centres de service.

Quando necesita servicio

Si su aspiradora Panasonic necesita servicio, busque el Centro de Servicio Panasonic o un Centro de Servicio PASC autorizado más cercano bajo "Servicio de Electrodomésticos" en las páginas amarillas de la guía de teléfonos o llame gratis al 1-800-211-PANA (7262) para encontrar un centro de servicio conveniente. No mande el producto a las Executive o Regional Sales Offices. No están equipadas para arreglar estos productos.

Si manda el producto

Empaquete con cuidado en el cartón original si posible y mándelo prepagado y con seguro suficiente. Ponga una carta con sellos en la que describe su problema con el producto en el exterior del cartón. No mande el producto a las Executive o Regional Sales Offices. No están equipadas para arreglar estos productos.

PANAMEX COMPANY
DIVISION OF PANASONIC CORPORATION OF NORTH AMERICA

One Panasonic Way
Secaucus, New Jersey 07094
World Wide Web Address
<http://www.panasonic.com>

ACØ1ZDGCZØØØ
CØ1ZDGC1ØØØØ

Printed in Mexico
Imprimé au Mexique
Impreso en México