

Panasonic®

COMMERCIAL VACUUM CLEANER
Aspirateur commercial
Aspiradora comercial

MC-GG773

Operating Instructions
Manuel d'utilisation
Instrucciones de operación

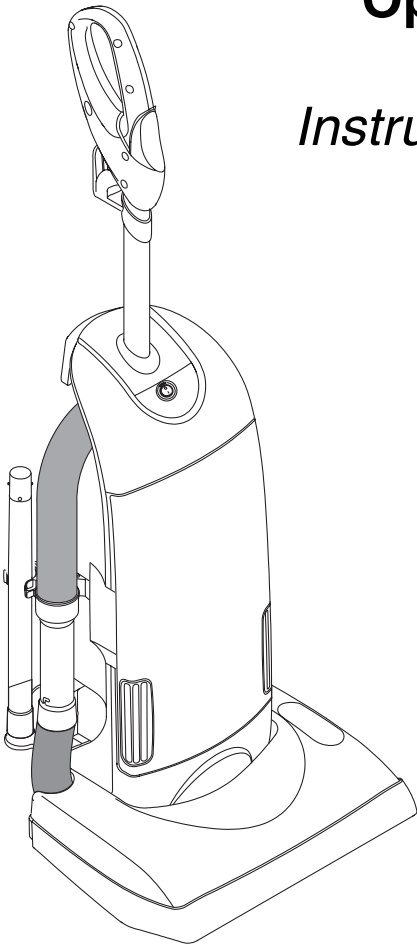

**Before operating your vacuum cleaner,
please read these instructions completely.**

Avant d'utiliser l'appareil, il est recommandé
de lire attentivement ce manuel.

*Antes de usar su aspiradora, lea
completamente estas instrucciones por favor.*

CONSUMER INFORMATION

Please read **IMPORTANT SAFETY INSTRUCTIONS** on page 5 before use. Read and understand all instructions.

TO OUR VALUED CUSTOMER

We are very pleased to welcome you to the Panasonic family of products. Thank you for purchasing this product. Our intent is that you become one of our many satisfied customers.

Proper assembly and safe use of your vacuum cleaner are your responsibilities. Your vacuum cleaner is intended only for commercial use. The vacuum cleaner should be stored in a dry, indoor area. Read the Operating Instructions carefully for important use and safety information.

Special care is required when vacuuming certain types of carpet or floor covering. Always check the carpet or floor covering manufacturer's recommended cleaning instructions before vacuuming.

PLEASE PAY CLOSE ATTENTION TO ALL WARNING AND CAUTION STATEMENTS.

WARNING

WARNING statements are designed to alert you to the possibility of personal injury, loss of human life, and/or damage to the vacuum cleaner and/or personal property if the instructions given are not followed.

CAUTION

CAUTION statements are designed to alert you to the possibility of damage to the vacuum cleaner and/or personal property if the instructions given are not followed.

WARNING

TO AVOID ELECTRICAL SHOCK

Never vacuum damp or wet surfaces or liquids.
DO NOT store vacuum cleaner outdoors.
Replace worn or frayed power cord immediately.
Unplug from outlet when not in use and before servicing.

TO AVOID ACCIDENTS

Except for hand-held vacuum cleaners, keep vacuum cleaner on floor - not chairs, tables, steps, stairs, etc. Store vacuum cleaner promptly after each use to prevent accidents such as tripping over power cord or vacuum cleaner. Use vacuum cleaner and accessories only in a manner intended by the manufacturer. **The use of an extension cord other than the one provided with the vacuum cleaner is not recommended.**

IMPORTANT SAFETY INSTRUCTIONS

When using your vacuum cleaner, basic precautions should always be followed, including the following:

Read all instructions in this manual before assembling or using your vacuum cleaner.

WARNING To reduce the risk of fire, electrical shock, injury:

1. **Read** all instructions in this manual before assembling or using your vacuum cleaner.
2. **Use** your vacuum cleaner only as described in this manual. Use only with Panasonic recommended attachments.
3. **Disconnect** electrical supply before servicing or cleaning out the brush area. Failure to do so could result in the brush unexpectedly starting, causing personal injury from moving parts.
4. **Do not** leave vacuum cleaner when plugged in. Unplug from outlet when not in use and before servicing.
5. **To reduce** the risk of electrical shock - Do not use outdoors or on wet surfaces.
6. **Do not** allow to be used as a toy. Close attention is necessary when used by or near children.
7. **Do not** use with a damaged cord or plug. If vacuum cleaner is not working as it should, has been dropped, damaged, left outdoors, or dropped in water, return it to a Panasonic Service Center.
8. **Do not** pull or carry by cord, use cord as a handle, close a door on cord, or pull cord around sharp edges or corners. Do not run vacuum cleaner over cord. Keep cord away from heated surfaces.
9. **Do not** unplug by pulling on cord. To unplug, grasp the plug, not the cord.
10. **Do not** handle plug or vacuum cleaner with wet hands.
11. **Do not** put any objects into openings.
12. **Do not** use with any opening blocked; keep free of dust, lint, hair, and anything that may reduce air flow.
13. **Keep** hair, loose clothing, fingers, and all parts of body away from openings and moving parts.
14. **Turn off** all controls before unplugging.
15. **Use** extra care when cleaning on stairs. Do not put on chairs, tables, etc. Keep on floor.
16. **Do not** use vacuum cleaner to pick up flammable or combustible liquids (gasoline, cleaning fluid, perfumes, etc.), or use in areas where they may be present. The fumes from these substances can create a fire hazard or explosion.
17. **Do not** pick up anything that is burning or smoking, such as cigarettes, matches, or hot ashes.
18. **Do not** use vacuum cleaner without dust bag and/or filters in place.
19. **You are** responsible for making sure that your vacuum cleaner is not used by anyone unable to operate it properly.
20. **Connect** to a properly grounded outlet only. See Grounding Instructions.

SAVE THESE INSTRUCTIONS

THIS VACUUM CLEANER IS INTENDED FOR COMMERCIAL USE

NOTE: Before you plug in your Panasonic vacuum cleaner, make sure that the voltage indicated on the rating plate located at the back of the vacuum cleaner is the same as your local electrical supply.

TABLE OF CONTENTS

CONSUMER INFORMATION	2
IMPORTANT SAFETY INSTRUCTIONS	5
GROUNDING INSTRUCTIONS	10
PARTS IDENTIFICATION	12
FEATURE CHART	13
ASSEMBLY	14
Attaching Handle	14
Power / Extension Cord Retainer	16
Tool Storage	16
FEATURES	18
Automatic Self Adjusting Nozzle	18
Edge Cleaning	18
Thermal Protector	18
Motor Protector	20
TO OPERATE VACUUM CLEANER	22
ON-OFF Switch	22
Handle Adjustments	24
Tool Usage	24
ROUTINE CARE OF VACUUM CLEANER	26
Replacing Primary HEPA Filter	26
Replacing Secondary Filter	26
Changing Dust Bag	28
Removing and Installing Lower Plate	30
Replacing Belt	32
Agitator Assembly	34
Replacing Brushes	34
Cleaning Agitator	36
Cleaning Exterior and Tools	36
Removing Clogs	38
BEFORE REQUESTING SERVICE	40
WARRANTY	43,44
WHAT TO DO WHEN SERVICE IS NEEDED	48

GROUNDING INSTRUCTIONS

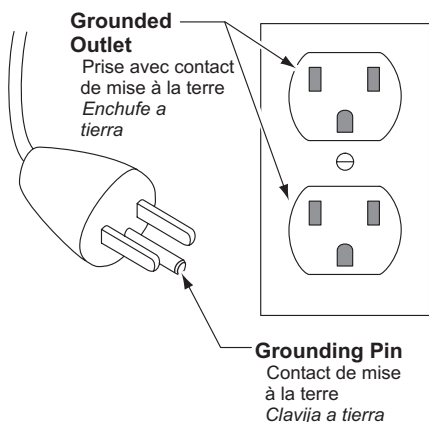

Figure A

Figure A
Figura A

This vacuum cleaner must be grounded. If it should malfunction or breakdown, grounding provides a path of least resistance for electric current to reduce the risk of electric shock. This vacuum cleaner is equipped with a cord having an equipment-grounding conductor and grounding plug. The plug must be plugged into an appropriate outlet that is properly installed and grounded in accordance with all local codes and ordinances.

! DANGER

Improper connection of the equipment-grounding conductor can result in a risk of electric shock. Check with a qualified electrician or service person if you are in doubt as to whether the outlet is properly grounded. Do not modify the plug provided with the vacuum cleaner – if it will not fit the outlet, have a proper outlet installed by a qualified electrician.

This vacuum cleaner is for use on a nominal 120-volt circuit, and has a grounding plug that looks like the plug illustrated in **Figure A**. Make sure that this vacuum cleaner is connected to an outlet having the same configuration as the plug.

No adapter should be used with this vacuum cleaner.

Note: Before you plug in your commercial vacuum cleaner, make sure that the voltage indicated on the rating plate located at the back of the vacuum cleaner is the same as your local supply.

PARTS IDENTIFICATION

Nomenclature Identificación de piezas

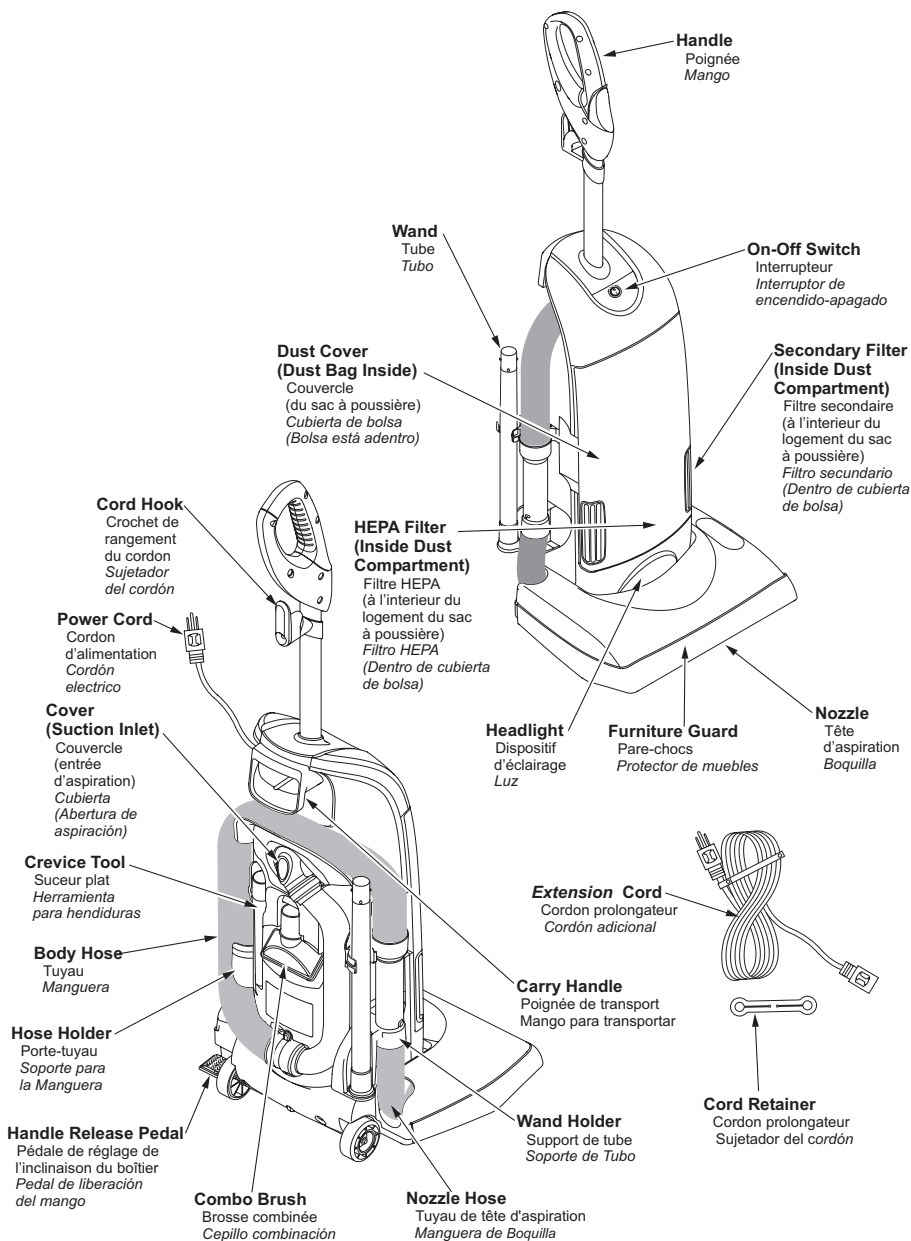

FEATURE CHART

Power	Thermal Protector	Cord Length	Tools
120V AC (60 Hz)	Yes	15.2 m (50 Ft.)	Yes

Tableau des caractéristiques

Alimentation	Protecteur thermique	Longueur du cordon	Accessoires
120 V c.a. (60 Hz)	Oui	15.2 m (50 pi)	Oui

Diagrama de características

Voltaje	Protector termal	Extensión de cordón	Herramientas
120 V c.a. (60 Hz)	Si	15.2 m (50 pi)	Si

ASSEMBLY

Attaching Handle

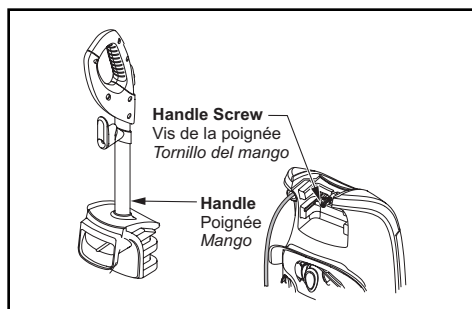

- 1)
 - **DO NOT** plug in until assembly is complete.
 - Remove handle screw from body.
 - Position the handle assembly as shown in the illustration.

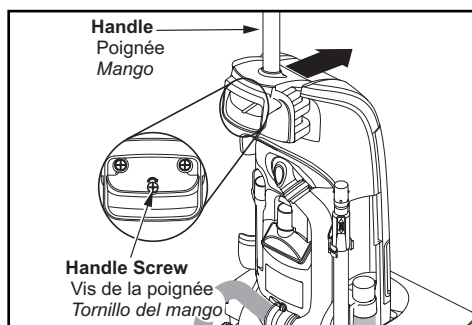

- 2)
 - Remove body hose from holder.
 - When installing the handle, firmly press the handle onto the body.
 - Insert and tighten handle screw.

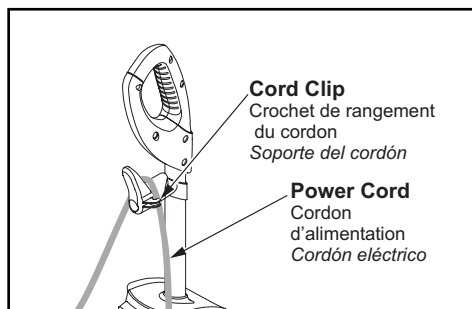

- 3)
 - Push power cord into cord clip.

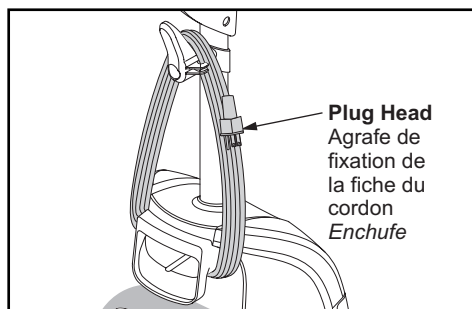

- 4)
 - Wrap power cord around cord hooks.
 - Secure retainer (plug head) to power cord.
 - Place the body hose back on the wand holder pressing firmly on the hose cuff. Make sure body hose is routed correctly on back of vacuum cleaner.

Power / Extension Cord Retainer

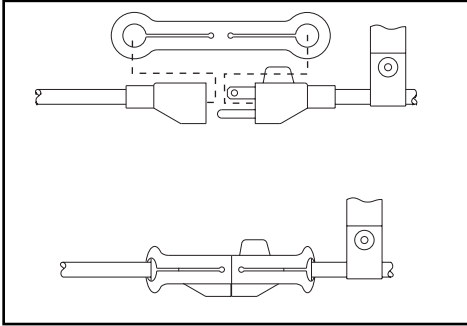

- This vacuum cleaner is equipped with a replaceable extension power cord.
- Use the cord retainer as illustrated to maintain the power cord - extension cord connection.

Tool Storage

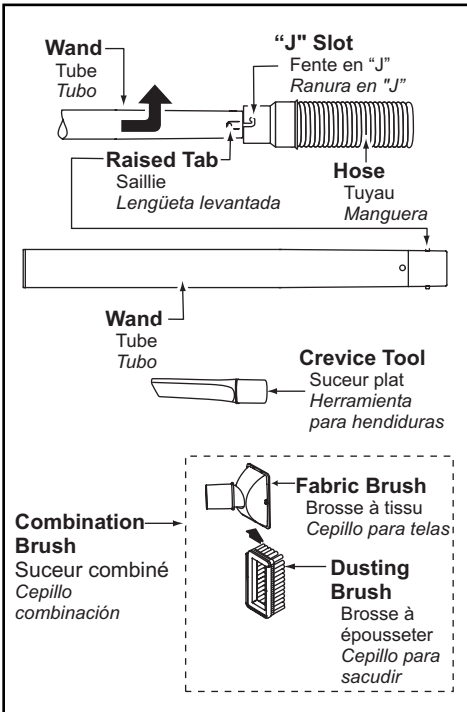

- Some tools may already be stored on vacuum cleaner.
- Place wand in center slot of tool holder.
- Refer to PARTS IDENTIFICATION section for tool location.

Arrêteur de cordon de
puissance/prolongation

- **This vacuum cleaner is equipped with a replaceable extension power cord.**
- **Use the cord retainer as illustrated to maintain the power cord - extension cord connection.**

*Sujetador del cordón
eléctrico / adicional*

- *Esta aspiradora esta equipada con un cordón eléctrico adicional reemplazable.*
- *Use el sujetador del cordón como se muestra para mantener la conexión del cordón eléctrico y el cordón eléctrico adicional.*

Rangement des accessoires

- Certains des accessoires peuvent être déjà rangés sur l'aspirateur.
- Ranger le tube dans la fente avant du porte-accessoires.
- Se reporter à l'illustration de la section « Nomenclature » pour le rangement approprié des accessoires.

Almacenaje de herramientas

- *Es posible que ya se almacenen unas herramientas en la aspiradora.*
- *Coloque el tubo en la ranura trasera del soporte para herramientas.*
- *Véase la sección de "Identificación de piezas" para la ubicación de las herramientas.*

FEATURES

Automatic Self Adjusting Nozzle

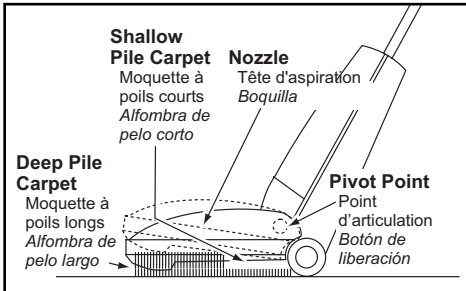

- The nozzle of your Panasonic upright vacuum cleaner automatically adjusts to any carpet pile height.
- Feature allows nozzle to float evenly over carpet pile surfaces.
- No manual adjustments required.

Edge Cleaning

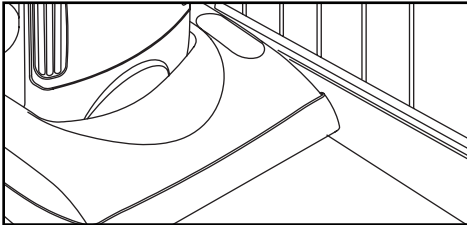

- Edge cleaning feature enables improved cleaning of carpets near walls and furniture.

Thermal Protector

- If a clog prevents the normal flow of air to the motor, the thermal protector turns the motor off automatically to allow the motor to cool in order to prevent possible damage to the vacuum cleaner.
- To correct problem, turn off and unplug vacuum cleaner, remove clogs, and/or clean/replace filters.
- Replace full bag if necessary.
- Wait approximately thirty (30) minutes, plug vacuum cleaner in, and turn on to see if thermal protector has reset. Thermal protector will not reset if vacuum cleaner is not turned off even if vacuum cleaner cools down.

Motor Protector

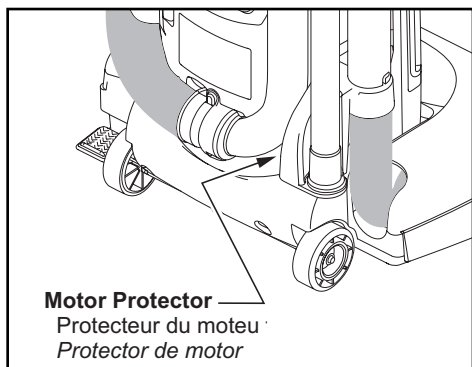

- The motor protector is located behind the wand holder on the back of the vacuum cleaner.
- Automatically opens to provide cooling air to the motor when a clog occurs or when dust bag is full.
- Motor protector may open when using tools.
- Check operation by placing hand over end of hose.
- If the motor protector opens, the vacuum cleaner will make a different sound.
- Do not block motor protector.

TO OPERATE VACUUM CLEANER

ON-OFF Switch

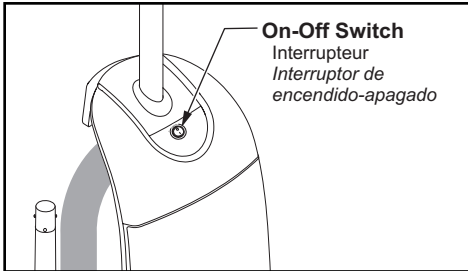

- Ensure “I / O” (ON-OFF) switch is OFF.
- Plug the power cord into 120V outlet.
- “I” position turns vacuum cleaner on.
- “O” position turns vacuum cleaner off.

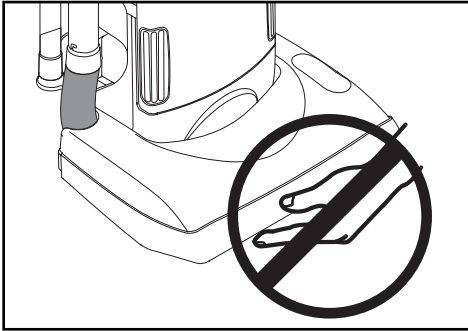

CAUTION

Moving parts! To reduce the risk of personal injury, DO NOT touch the brush when vacuum cleaner is on. Contacting the brush while it is rotating can cut, bruise or cause other injuries. Always unplug from electrical outlet before servicing. Use caution when operating near small children.

Handle Adjustments

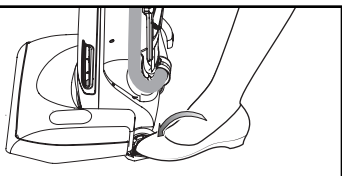

1)

- Step on handle release pedal to change handle position.

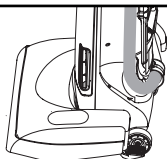

2)

- Move vacuum cleaner to upright position for storage and tool use.

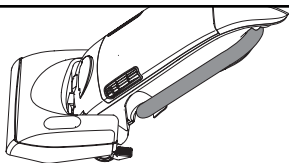

3)

- Move vacuum cleaner to middle position for normal use.

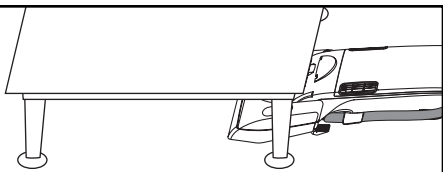

4)

- Use low position for cleaning under furniture.

Tool Usage

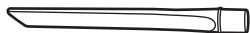

- The Crevice Tool may be used on the following items:

- Furniture
- Cushions
- Drapes
- Stairs
- Walls

Dusting Brush

Brosse à épousseter
Cepillo para sacudir



Fabric Brush
Brosse à tissu
Cepillo para telas

- The Combination Brush may be used on the following items:

- Furniture
- Drapes
- Stairs
- Walls

ROUTINE CARE OF VACUUM CLEANER

Performing the following tasks will keep your new Panasonic vacuum cleaner operating at peak performance levels and will ensure these high levels for years to come. Check the **BEFORE REQUESTING SERVICE** section in this manual for recommendations on performing some of these tasks to help solve various problems that may occur.

Replacing HEPA Filter

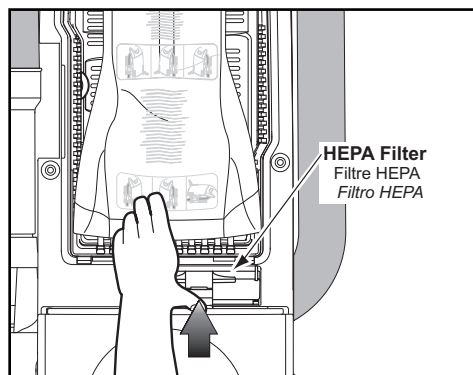

- Check filter when installing a new dust bag.
- If dirty, pull filter assembly from bottom of dust compartment and replace.
- Place new filter in the filter support*, air flow arrow side up, in dust compartment, **DO NOT CLEAN WITH WATER****.

Replacing Secondary Filter

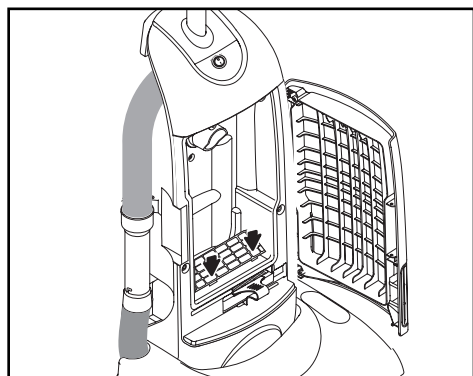

- Secondary filter protects the motor.
- Check filter assembly when installing a new dust bag.
- If dirty, pull filter from bottom of dust compartment.
- Place new filter, white side up, in filter supporter*, **DO NOT CLEAN WITH WATER****.
- Insert filter assembly tabs into the front dust compartment slots then push down into place*.

Note: * Ensure filter is fully inserted.

** Filters cannot be cleaned and should be replaced at least once each year.

Changing Dust Bag

Always operate vacuum cleaner with genuine Panasonic Type U12 Electrostatic or U10 HEPA dust bags installed. Panasonic dust bags may be purchased through any authorized Panasonic dealer or ordered from service company.

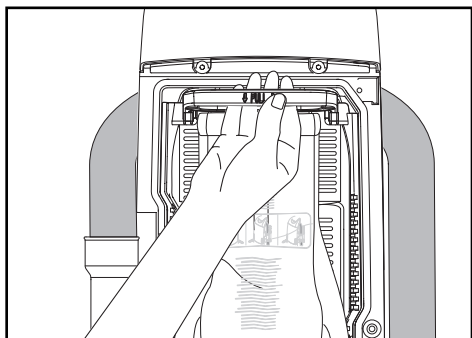

1)

- Pull down and outward on bag holder handle to remove from cavity.

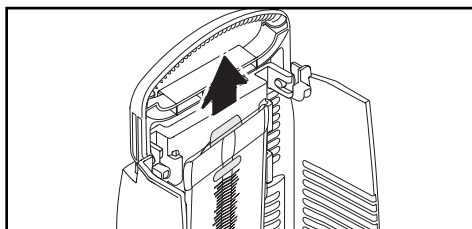

2)

- Pull the cardboard collar of the dust bag sliding the dust bag out of bag holder.

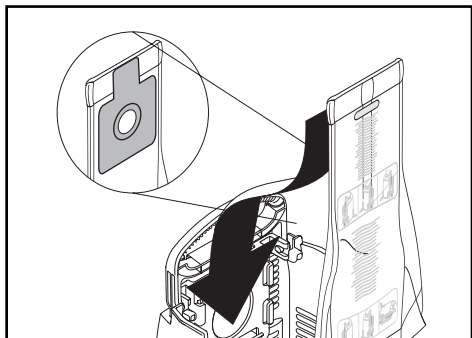

3)

- Spread out new dust bag, taking care not to tear bag.

4)

- Attach new dust bag onto bag holder by holding cardboard collar and sliding it back into the bag holder.

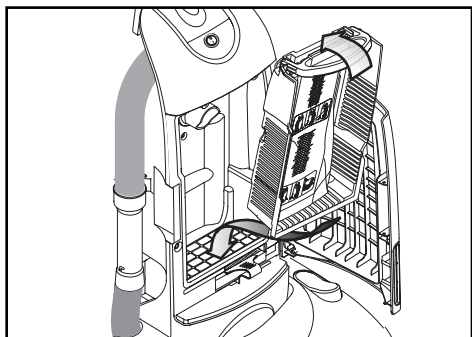

5)

- Reinsert tabs on the bottom of bag holder into groove on the front of secondary filter.

6)

- Hold down the handle and push back the bag holder, press into place without pinching dust bag, release the handle.

! WARNING Electrical Shock or Personal Injury Hazard

Disconnect the electrical supply before servicing or cleaning the vacuum cleaner. Failure to do so could result in electrical shock or personal injury from vacuum cleaner suddenly starting.

Removing and Installing Lower Plate

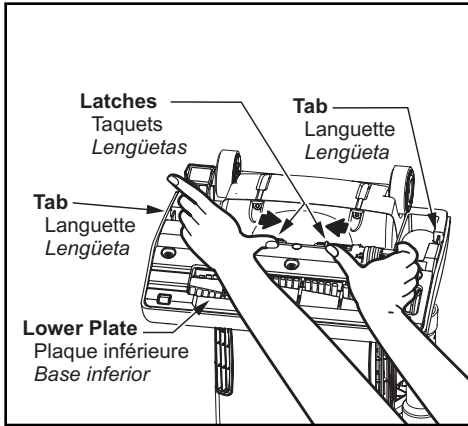

➤ **Before servicing any parts, disconnect vacuum cleaner from electrical outlet.**

➤ **Place paper under nozzle whenever lower plate is removed to protect floor from dirt and debris that may still be remaining in the nozzle chamber.**

➤ **Place handle in upright position and turn vacuum cleaner over to expose lower plate.**

➤ **Release lower plate by pressing two (2) latches and two (2) tabs inward.**

➤ **Remove lower plate and remove any residue that may exist in belt area.**

➤ **Reinstall lower plate by hooking front end of lower plate into slots on front of nozzle housing.**

➤ **Press lower plate into place then push two (2) latches outward.**

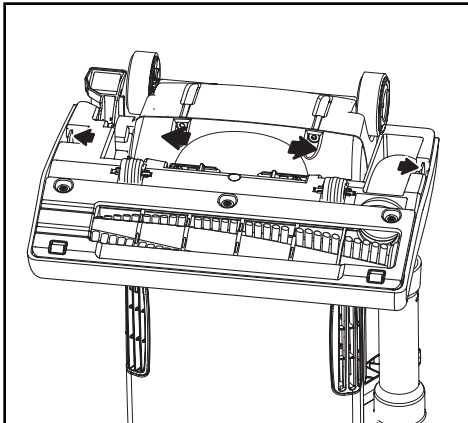

Replacing Belt

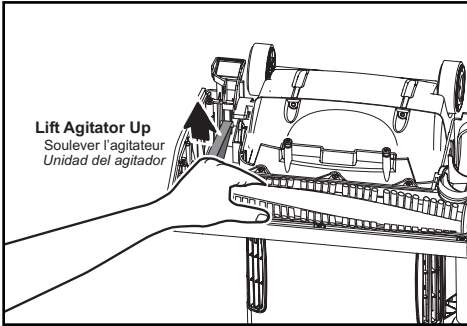

- Replace belt whenever a burning rubber smell caused by excessive belt slippage occurs.
- Remove lower plate. See: "Removing and Installing Lower Plate"
- Remove agitator by carefully lifting out.

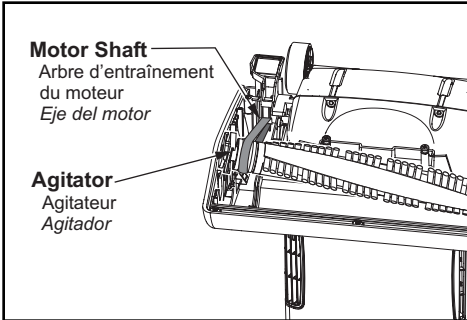

- Remove worn or broken belt.
- Clean agitator. See: "Cleaning Agitator"
- Loop new belt (Panasonic Type UB8 only) around motor shaft and agitator pulley; see illustration for correct belt routing.

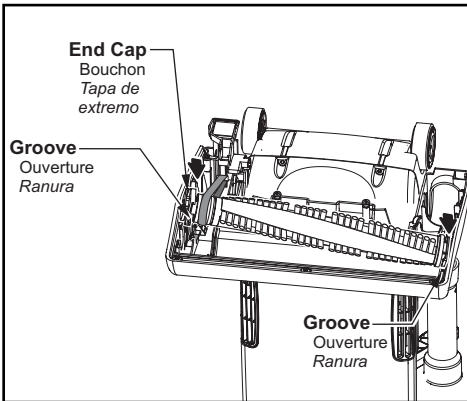

- Reinstall agitator back into nozzle housing grooves.
- After reinstalling the agitator, turn it by hand to make sure the belt is not twisted or pinched and that all rotating parts turn freely.
- Reinstall lower plate. See: "Removing and Installing Lower Plate"

Agitator Assembly

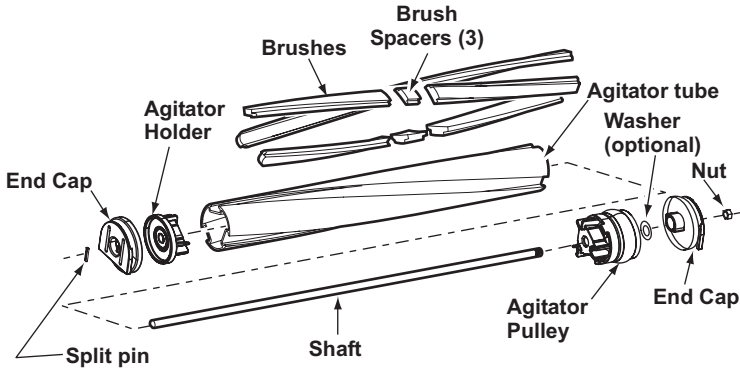

Replacing Brushes



- When the bristles on the agitator are worn so that they do not touch a card held across the lower plate, the brushes should be replaced.

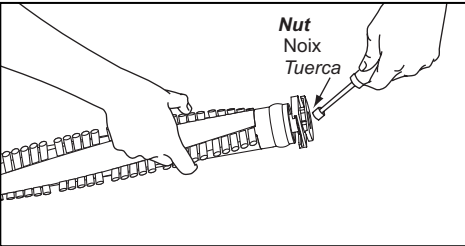

- Remove lower plate and agitator.
- Remove the nut from agitator shaft and end cap.
- Do not bend agitator shaft or lose nut or washer.
- Pull agitator shaft out of agitator body.

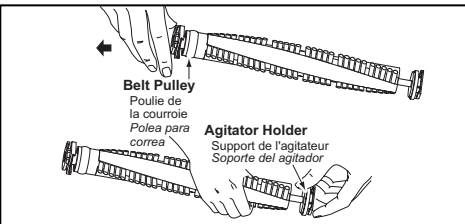

- Pull, or pry out, agitator holder and agitator pulley.
- Push each brush out of agitator body as shown.
- Install new brushes by reversing procedure.
- Reinstall agitator holder and agitator pulley completely.

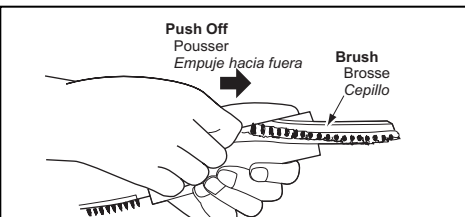

- Reinstall the agitator shaft, washer, end cap and nut.
- See exploded view for correct assembly of parts.
- Position belt over agitator pulley on the agitator.
- Reinstall agitator and lower plate.

Cleaning Agitator

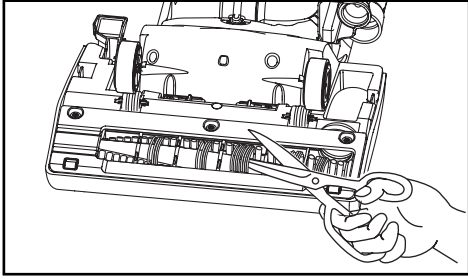

- Clean agitator after every five uses and every time the belt is replaced.
- Remove lower plate. See: “Removing and Installing Lower Plate”
- Cut off any hair, thread, string, carpet pile, and lint entangled around agitator with a pair of scissors.
- Remove agitator. See: “Replacing Belt”
- Remove any string or debris located on the end caps, washers or agitator shaft.
- Reinstall agitator and lower plate. See: “Removing and Installing Lower Plate”

Cleaning Exterior and Tools

- Clean exterior using a clean, soft cloth that has been dipped in a solution of mild liquid detergent and water and wrung dry.
- DO NOT drip water on vacuum cleaner
- Wipe dry after cleaning.
- DO NOT clean tools in dishwasher or clothes washer.
- Wash tools in warm soapy water, rinse and air dry.
- DO NOT use tools if they are wet.

Removing Clogs

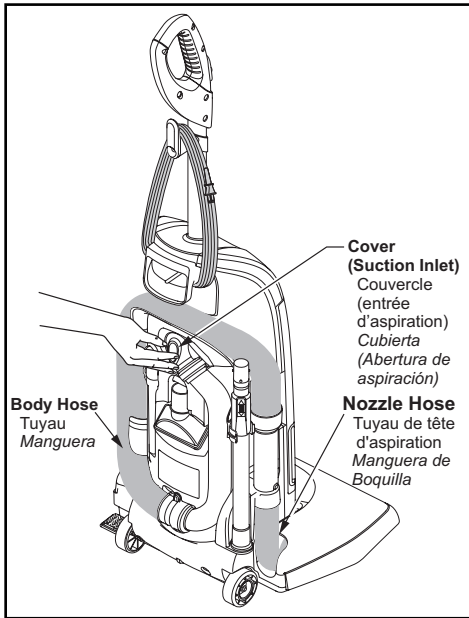

The body hose located on the back of the vacuum cleaner carries the dirt from the nozzle up to the dust bag. If the hose should become clogged:

- **Unplug vacuum cleaner.**
- **Pull open suction inlet cover and check for clogging. Secure suction inlet cover properly after checking.**
- **Disconnect body hose from wand holder and check hose ends.**
- **Plug in vacuum cleaner and turn on.**
- **Stretch body hose in and out to remove clogs that may not be seen.**
- **If clog still exists, turn vacuum cleaner OFF and UNPLUG POWER CORD.**
- **Remove lower plate. See: "Removing and Installing Lower Plate"**
- **Inspect inlet of nozzle hose and clear any obstructions.**

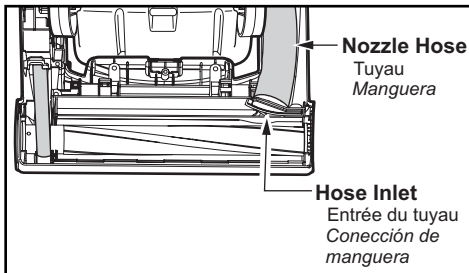

BEFORE REQUESTING SERVICE



WARNING

Electrical Shock or Personal Injury Hazard

Disconnect the electrical supply before servicing or cleaning the vacuum cleaner. Failure to do so could result in electrical shock or personal injury from vacuum cleaner suddenly starting.

Review this chart to find do-it-yourself solutions for minor performance problems. Any service needed, other than those described in these Operating Instructions, should be performed by an authorized service representative.

PROBLEM	POSSIBLE CAUSE	POSSIBLE SOLUTION
Vacuum cleaner will not run.	<ol style="list-style-type: none"> 1. Unplugged at wall outlet. 2. ON-OFF switch not turned on. 3. Tripped circuit breaker/blown fuse at household service panel. 4. Tripped thermal protector. 	<ol style="list-style-type: none"> 1. Plug in firmly. Push ON-OFF switch to ON. 2. Push ON-OFF switch to ON. 3. Reset circuit breaker or replace fuse. 4. Unplug vacuum cleaner, wait thirty (30) minutes, plug in and switch to ON.
Poor job of dirt pickup.	<ol style="list-style-type: none"> 1. Full or clogged dust bag. 2. Broken belt. 3. Clogged body or nozzle hose. 4. Body hose not inserted fully. 5. Worn agitator. 6. Hole in body or nozzle hose. 7. Dust cover improperly installed. 8. Belt not installed on motor shaft. 	<ol style="list-style-type: none"> 1. Change dust bag. 2. Replace belt. 3. Clean body or nozzle hose area. 4. Insert body hose. 5. Replace agitator. 6. Replace body or nozzle hose. 7. Properly install dust cover. 8. Install belt on motor shaft.
Dust escapes the dust bag.	<ol style="list-style-type: none"> 1. Bag improperly installed. 2. Bag torn. 	<ol style="list-style-type: none"> 1. Properly install bag. 2. Replace bag.
Bag holder does not assemble properly	<ol style="list-style-type: none"> 1. Secondary filter improperly installed 	<ol style="list-style-type: none"> 1. Properly install secondary filter

WARRANTY

Panasonic Commercial Vacuum Cleaner Limited Warranty

Panasonic Consumer Electronics Company (collectively referred to as “the warrantor”) will repair this product with new or refurbished parts free of charge, in the U.S.A. or Puerto Rico for one (1) year from the date of original purchase in the event of a defect in materials or workmanship.

This Limited Warranty Excludes both Labor and Parts for the following items which require normal replacement: Disposable Dust Bag, Filters, Belts, Light Bulbs, Agitator Brushes and Batteries (if supplied).

Carry-in or mail-in service in the U.S.A. can be obtained during the warranty period by contacting a Panasonic Services Company (PASC) Factory Servicenter listed in the Servicenter Directory. Or call, toll free, 1-800-211-PANA (7262) to locate a PASC Authorized Servicenter. Carry-in or mail-in service in Puerto Rico can be obtained during the warranty period by calling the local Panasonic Sales Company telephone number listed in the Servicenter Directory.

This warranty is extended only to the original purchaser. A purchase receipt or other proof of date of original purchase will be required before warranty performance is rendered.

This warranty only covers failures due to defects in materials and workmanship which occur during normal use and does not cover damages which occur in shipment, or failures which are caused by products not supplied by the warrantor, or failures which result from accident, misuse, abuse, neglect, bug infestation, mishandling, misapplication, faulty installation, improper operation or maintenance, alteration, modification, power line surge, improper voltage supply, lightning damage, or service by anyone other than a PASC Authorized Servicenter, or damage that is attributable to acts of God.

LIMITS AND EXCLUSIONS:

There are no express warranties except as listed above.

THE WARRANTOR SHALL NOT BE LIABLE FOR INCIDENTAL OR CONSEQUENTIAL DAMAGES RESULTING FROM THE USE OF THIS PRODUCT, OR ARISING OUT OF ANY BREACH OF THIS WARRANTY. ALL EXPRESS AND IMPLIED WARRANTIES, INCLUDING THE WARRANTIES OF MERCHANTABILITY AND FITNESS FOR A PARTICULAR PURPOSE, ARE LIMITED TO THE APPLICABLE WARRANTY PERIOD SET FORTH ABOVE.

Some states do not allow the exclusion or limitation of incidental or consequential damages, or limitations on how long an implied warranty lasts, so the above exclusions or limitations may not apply to you.

This warranty gives you specific legal rights and you may also have other rights which vary from state to state. If a problem with this product develops during or after the warranty period, you may contact your dealer or Servicenter. If the problem is not handled to your satisfaction, then write to the Consumer Affairs Department at the listed address on the back cover.

WARRANTY

Panasonic Canada Inc.
5770 Ambler Drive, Mississauga, Ontario L4W 2T3

Panasonic Commercial Vacuum Cleaner Limited Warranty

Panasonic Canada Inc. warrants this product to be free from defects in material and workmanship and agrees to remedy any such defect for a period as stated below from the date of original purchase.

Commercial Vacuum Cleaner - Ninety (90) days parts and labour

LIMITATIONS AND EXCLUSIONS

This warranty does not apply to products purchased outside Canada or to any product which has been improperly installed, subjected to usage for which the product was not designed, misused or abused, damaged during shipping, or which has been altered or repaired in any way that affects the reliability or detracts from the performance. Parts such as disposable dust bags, filters, belts, light bulbs and agitator brushes are also excluded from coverage under this warranty. This warranty is extended to the original end user purchaser only. A purchase receipt or other proof of date of original purchase is required before warranty service is performed.

THIS EXPRESS, LIMITED WARRANTY IS IN LIEU OF ALL OTHER WARRANTIES, EXPRESS OR IMPLIED, INCLUDING ANY IMPLIED WARRANTIES OF MERCHANTABILITY AND FITNESS FOR A PARTICULAR PURPOSE. IN NO EVENT WILL PANASONIC CANADA INC. BE LIABLE FOR ANY SPECIAL, INDIRECT OR CONSEQUENTIAL DAMAGES.

In certain instances, some jurisdictions do not allow the exclusion or limitation of incidental or consequential damages, or the exclusion of implied warranties, so the above limitations and exclusions may not be applicable.

WARRANTY SERVICE

FOR PRODUCT OPERATION ASSISTANCE, please contact:

Our Customer Care Centre:	Telephone #:	(905) 624-5505
	1-800 #:	1-800-561-5505
	Fax #:	(905) 238-2360
	Email link:	"Contact Us" on www.panasonic.ca

FOR PRODUCT REPAIRS, please locate your nearest Authorized Servicentre at www.panasonic.ca :

Link : "Servicentres™ locator" under "Customer support"

IF YOU SHIP THE PRODUCT TO A SERVICENTRE

Carefully pack and send prepaid, adequately insured and preferably in the original carton.
Include details of the defect claimed, and proof of date of original purchase.

Ref: VAC_CommercialwarEng_Apr06

WHAT TO DO WHEN SERVICE IS NEEDED

If your Panasonic Vacuum Cleaner needs service, look in the yellow pages of the telephone book under HOME APPLIANCE SERVICE for your nearest Panasonic Services Company ("PASC") Factory Servicenter, or PASC authorized Servicenter, or call, 1-800-211-PANA (7262) toll free to find a convenient servicenter. **DO NOT send the product to the Executive or Regional Sales offices. They are NOT equipped to make repairs.**

If you ship the product

Carefully pack and send it prepaid, adequately insured and preferably in the original carton. Attach a postage-paid letter to the outside of the carton, which contains a description of your complaint. **DO NOT send the product to the Executive or Regional Sales Offices. They are NOT equipped to make repairs.**

**PANASONIC CONSUMER ELECTRONICS COMPANY
DIVISION OF MATSUSHITA ELECTRIC CORPORATION OF AMERICA**

One Panasonic Way
Secaucus, New Jersey 07094
World Wide Web Address
<http://www.panasonic.com>

What to do when service is needed Service après-vente (Canada)

WARRANTY SERVICE

For product operation and information assistance, please contact your Dealer or our Customer Care Centre at:

Telephone #: (905) 624-5505

Fax #: (905) 238-2360

Web: www.panasonic.ca

For product repairs, please contact one of the following:

- Your Dealer who will inform you of an authorized Servicentre nearest you.
- Our Customer Care Centre at (905) 624-5505 or www.panasonic.ca

RÉPARATION SOUS GARANTIE

Pour de l'aide sur le fonctionnement de l'appareil ou pour toute demande d'information, veuillez contacter votre détaillant ou notre service à la clientèle au :

N° de téléphone : (905) 624-5505 N° de télécopieur : (905) 238-2360 Site Internet : www.panasonic.ca

Pour la réparation des appareils, veuillez consulter :

- votre détaillant, lequel pourra vous renseigner sur le centre de service agréé le plus près de votre domicile ;
- notre service à la clientèle au (905) 624-5505 ou www.panasonic.ca;
- un de nos centres de service indiqué sur la page de garantie.

Quando necesita servicio

Si su aspiradora Panasonic necesita servicio, busque el Centro de Servicio Panasonic o un Centro de Servicio PASC autorizado más cercano bajo "Servicio de Electrodomésticos" en las páginas amarillas de la guía de teléfonos o llame gratis al 1-800-211-PANA (7262) para encontrar un centro de servicio conveniente. No mande el producto a las Executive o Regional Sales Offices. No están equipadas para arreglar estos productos.

Si manda el producto

Empaquete con cuidado en el cartón original si posible y mándelo prepagado y con seguro suficiente. Ponga una carta con sellos en la que describe su problema con el producto en el exterior del cartón. No mande el producto a las Executive o Regional Sales Offices. No están equipadas para arreglar estos productos.

**PANAMEX COMPANY
DIVISION OF PANASONIC CORPORATION OF NORTH AMERICA**

One Panasonic Way
Secaucus, New Jersey 07094
World Wide Web Address
<http://www.panasonic.com>

AC01ZDEKZ000
C01ZDEK000000

Printed in Mexico
Imprimé au Mexique
Impreso en Mexico