

Panasonic®

VACUUM CLEANER

Aspirateur

Aspiradora

MC-UG471

Operating Instructions

Manuel d'utilisation

Instrucciones de operación

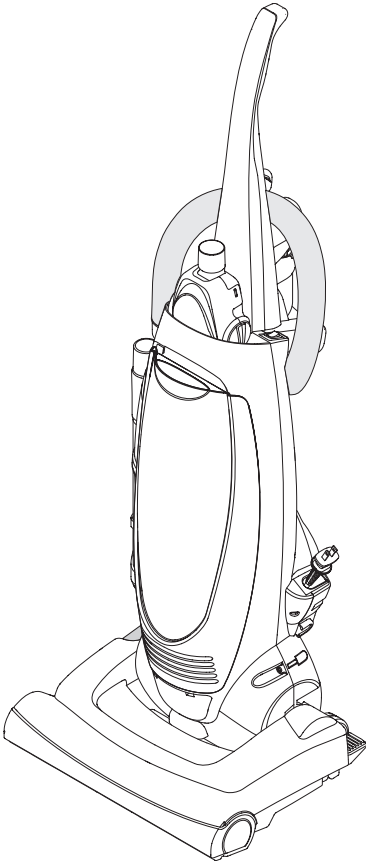

**Before operating your vacuum cleaner,
please read these instructions completely.**

Avant d'utiliser l'appareil, il est recommandé
de lire attentivement ce manuel.

*Antes de usar su aspiradora, lea
completamente estas instrucciones por favor.*

CONSUMER INFORMATION

Please read **IMPORTANT SAFETY INSTRUCTIONS** on page 5 before use. Read and understand all instructions.

TO OUR VALUED CUSTOMER

We are very pleased to welcome you to the Panasonic family of products. Thank you for purchasing this product. Our intent is that you become one of our many satisfied customers.

Proper assembly and safe use of your vacuum cleaner are your responsibilities. Your vacuum cleaner is intended only for household use. The vacuum cleaner should be stored in a dry, indoor area. Read the Operating Instructions carefully for important use and safety information.

Special care is required when vacuuming certain types of carpet or floor covering. Always check the carpet or floor covering manufacturer's recommended cleaning instructions before vacuuming.

PLEASE PAY CLOSE ATTENTION TO ALL WARNING AND CAUTION STATEMENTS.

WARNING

WARNING statements are designed to alert you to the possibility of personal injury, loss of human life, and/or damage to the vacuum cleaner and/or personal property if the instructions given are not followed.

CAUTION

CAUTION statements are designed to alert you to the possibility of damage to the vacuum cleaner and/or personal property if the instructions given are not followed.

WARNING

TO AVOID ELECTRICAL SHOCK

Never vacuum damp or wet surfaces or liquids.
DO NOT store vacuum cleaner outdoors.
Replace worn or frayed power cord immediately.
Unplug from outlet when not in use and before servicing.

TO AVOID ACCIDENTS

Except for hand-held cleaners, keep vacuum cleaner on floor – not chairs, tables, steps, stairs, etc.
Store vacuum cleaner promptly after each use to prevent accidents such as tripping over power cord or vacuum cleaner.
Use vacuum cleaner and accessories only in a manner intended by the manufacturer.
The use of an extension cord is not recommended.

IMPORTANT SAFETY INSTRUCTIONS

When using your vacuum cleaner, basic precautions should always be followed
READ ALL INSTRUCTIONS BEFORE USING THIS VACUUM CLEANER

WARNING

To reduce the risk of fire, electrical shock, injury:

1. **Read** all instructions in this manual before assembling or using your vacuum cleaner.
2. **Use** your vacuum cleaner only as described in this manual. Use only with Panasonic recommended attachments.
3. **Disconnect** electrical supply before servicing or cleaning out the brush area. Failure to do so could result in electrical shock or the brush suddenly starting.
4. **Do not** leave vacuum cleaner when plugged in. Unplug from outlet when not in use and before servicing.
5. **To reduce** the risk of electrical shock - Do not use outdoors or on wet surfaces.
6. **Do not** allow to be used as a toy. Close attention is necessary when used by or near children.
7. **Do not** use with a damaged cord or plug. If vacuum cleaner is not working as it should, has been dropped, damaged, left outdoors, or dropped in water, return it to a Panasonic Service Center.
8. **Do not** pull or carry by cord, use cord as a handle, close a door on cord, or pull cord around sharp edges or corners. Do not run vacuum cleaner over cord. Keep cord away from heated surfaces.
9. **Do not** unplug by pulling on cord. To unplug, grasp the plug, not the cord.
10. **Do not** handle plug or vacuum cleaner with wet hands.
11. **Do not** put any objects into openings.
12. **Do not** use with any opening blocked; keep free of dust, lint, hair, and anything that may reduce air flow.
13. **Keep** hair, loose clothing, fingers, and all parts of body away from openings and moving parts.
14. **Turn off** all controls before unplugging.
15. **Use** extra care when cleaning on stairs. Do not put on chairs, tables, etc. Keep on floor.
16. **Do not** use vacuum cleaner to pick up flammable or combustible liquids (gasoline, cleaning fluid, perfumes, etc.), or use in areas where they may be present. The fumes from these substances can create a fire hazard or explosion.
17. **Do not** pick up anything that is burning or smoking, such as cigarettes, matches, or hot ashes.
18. **Do not** use vacuum cleaner without dust bag and/or filters in place.
19. **Do not** operate vacuum cleaner without the belt access door properly installed (if applicable).
20. **Unplug** before connecting Air Turbine. (if applicable).
22. **Hold** plug when rewinding onto cord reel. Do not allow plug to whip when rewinding.
21. **You are** responsible for making sure that your vacuum cleaner is not used by anyone unable to operate it properly.

SAVE THESE INSTRUCTIONS

THIS VACUUM CLEANER IS INTENDED FOR HOUSEHOLD USE ONLY

NOTE: Before you plug in your Panasonic vacuum cleaner, make sure that the voltage indicated on the rating plate located at the back of the vacuum cleaner is the same as your local electrical supply.

TABLE OF CONTENTS

CONSUMER INFORMATION	2
IMPORTANT SAFETY INSTRUCTIONS	5
PARTS IDENTIFICATION	10
ASSEMBLY	12
Attaching Handle	12
Hose	14
Tool Storage	14
FEATURES	16
Cord Reel	16
Automatic Self-Adjusting Nozzle	16
Motor Protector	18
Thermal Protector	18
Edge Cleaning	20
TO OPERATE VACUUM CLEANER	20
Power Cord	20
ON-OFF Switch	20
Handle Adjustment	22
Using Tools	22
ROUTINE CARE OF VACUUM CLEANER	24
Changing Dust Bag	24
Cleaning Secondary Foam Filter	28
Replacing HEPA Exhaust Filter	28
Removing and Installing Lower Plate	30
Replacing Belt	32
Replacing Headlight Bulb	34
Replacing Agitator	36
Cleaning Agitator	36
Cleaning Exterior	38
Removing Clogs	40
BEFORE REQUESTING SERVICE	42
WARRANTY	45, 46
Notes	49-51
WHAT TO DO WHEN SERVICE IS NEEDED	52

PARTS IDENTIFICATION

Nomenclature Identificación de piezas

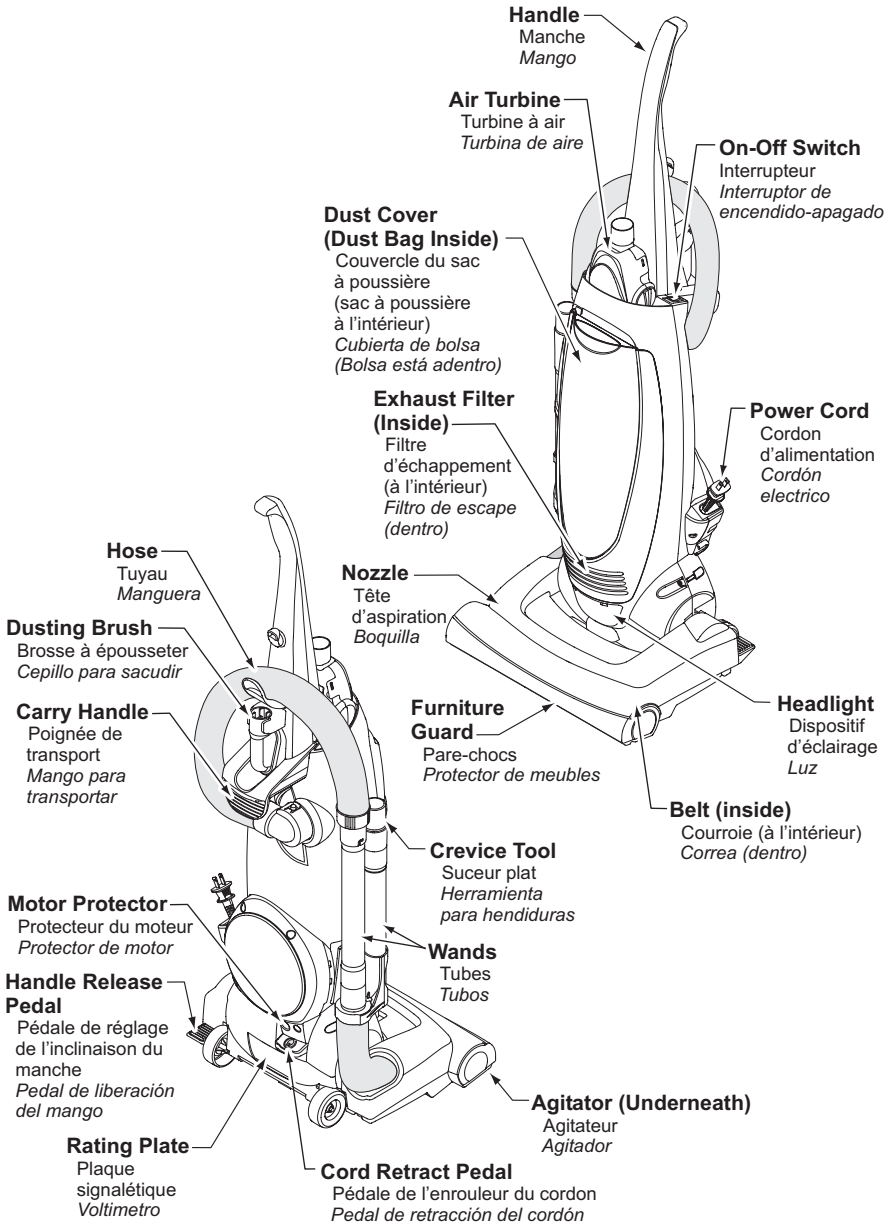

FEATURE CHART

Power	Motor Protector	Cord Length	Tools
120V AC(60Hz)	Yes	7.6 m (25 Ft.)	Yes

Tableau des caractéristiques

Alimentation	Protecteur du moteur	Longueur du cordon	Accessoires
120V c.a. (60Hz)	Oui	7,6 m (25 pi)	Oui

Diagrama de características

<i>Voltaje</i>	<i>Protector de motor</i>	<i>Extensión de cordón</i>	<i>Herramientas</i>
120V c.a. (60Hz)	Si	7,6 m (25 pi)	Si

ASSEMBLY

Attaching Handle

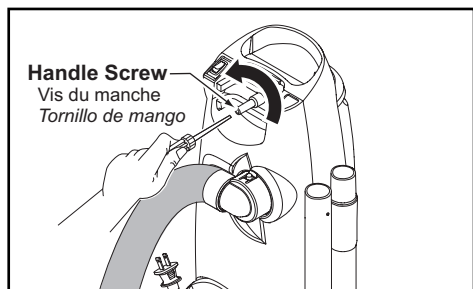

- **DO NOT** plug in until assembly is complete.
- Remove handle screw.
- Slide handle into the opening at the top of the vacuum cleaner.

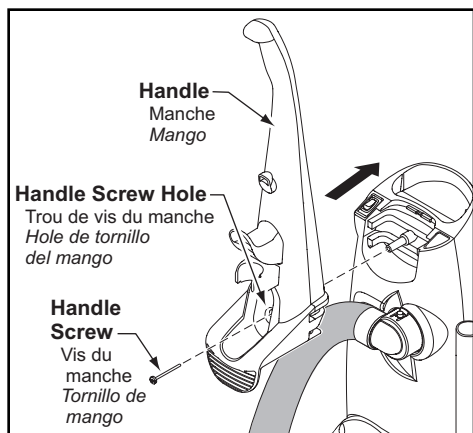

- Insert handle screw so that it passes through the handle and into the vacuum cleaner.
- Begin to tighten the handle screw with fingers. It may be necessary to adjust the handle slightly.
- Using a screwdriver, tighten the handle screw.
- **DO NOT** overtighten. Overtightening could strip the screw hole.
- **DO NOT** operate the vacuum cleaner without handle screw in place.



HOSE

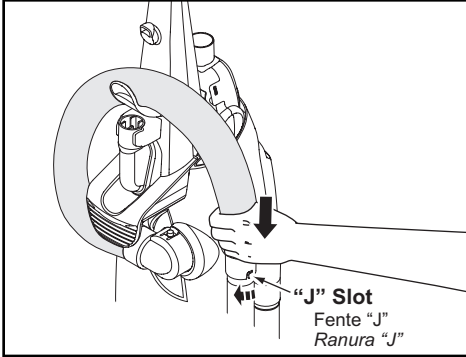

- Loop the hose over the handle and align "J" slots in the hose with the tabs on the extension wand.
- Push the hose onto the wand and twist to lock in place.

TOOL STORAGE

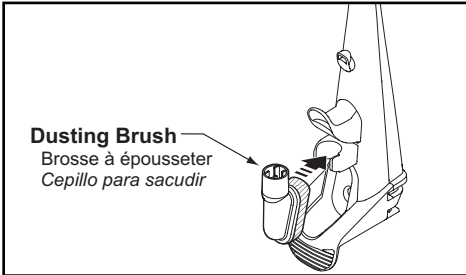

DUSTING BRUSH

- Place the dusting brush into the back of the handle in the storage locations as shown.

AIR TURBINE

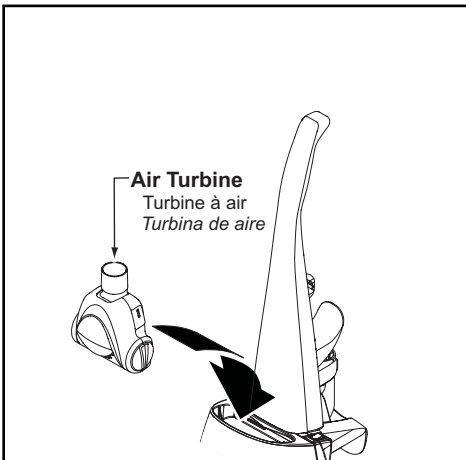

- Place the Air Turbine into the storage compartment.
- Push the Air Turbine down until it snaps into place
- To remove, pull Air Turbine out of storage location
- For operation of the Air Turbine see separate owner's manual.

FEATURES

Cord Reel

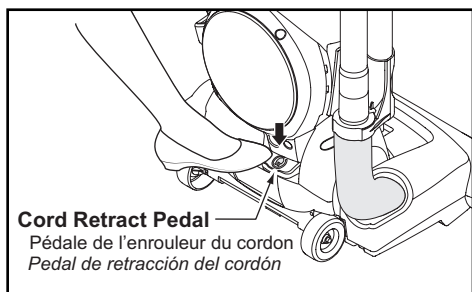
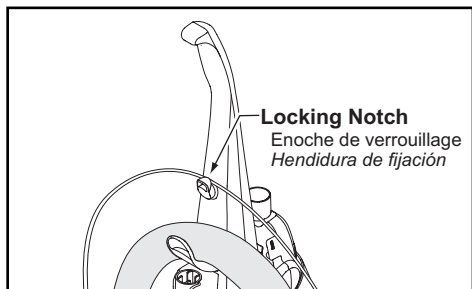

- Pull cord out of cord reel until the end is reached.
- Do not use vacuum cleaner without cord pulled out all the way.
- Push power cord into two (2) cord clips in back of handle.
- Plug the polarized power cord into a 120V outlet located near floor.
- To prevent injury or damage, hold plug head while rewinding cord.
- Push cord retract pedal down to rewind.

Automatic Self-Adjusting Nozzle

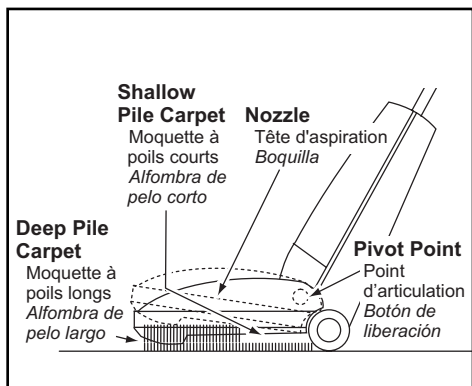

- The nozzle of your Panasonic upright vacuum cleaner automatically adjusts to any carpet pile height.
- Feature allows nozzle to float evenly over carpet pile surfaces.
- No manual adjustments required.

Motor Protector

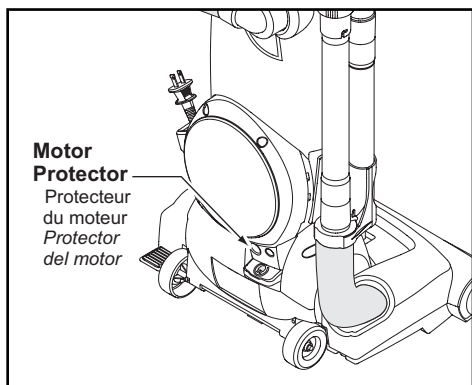

- The motor protector automatically opens to provide cooling air to the motor when a clog occurs or when dust bag needs changing.
- Motor protector may open when using tools.
- If motor protector opens, the vacuum cleaner will make a slightly different sound.

Note: Do not block motor protector.

Thermal Protector

- If a clog prevents the normal flow of air to the motor, the thermal protector turns the motor off automatically to allow the motor to cool in order to prevent possible damage to the vacuum cleaner.
- To correct problem, turn off and unplug vacuum cleaner, remove clogs, and/or clean/replace filters.
- Replace full bag if necessary.
- Wait approximately thirty (30) minutes, plug vacuum cleaner in, turn on to see if thermal protector has reset. Thermal protector will not reset if vacuum cleaner is not turned off even if vacuum cleaner cools down.

Edge Cleaning

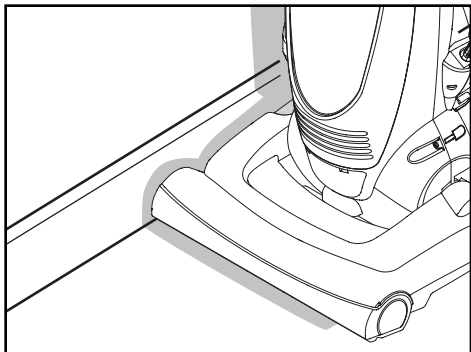

- Edge cleaning feature enables improved cleaning of carpets near walls and furniture.

TO OPERATE VACUUM CLEANER

Power Cord

NOTE: To reduce the risk of electrical shock, this vacuum cleaner has a polarized plug, one blade is wider than the other. This plug will fit in a polarized outlet only one way. If the plug does not fit fully in the outlet, reverse the plug. If it still does not fit, contact a qualified electrician to install the proper outlet. **DO NOT CHANGE THE PLUG IN ANY WAY.** Only use outlets near the floor.

ON-OFF Switch

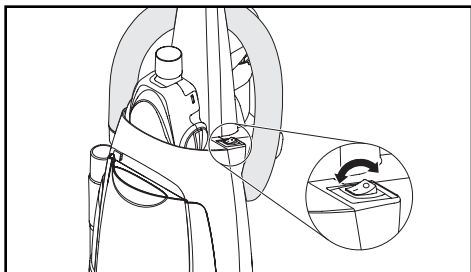

- Ensure ON-OFF switch is OFF.
- Plug the power cord into 120V outlet.
- ON position turns vacuum cleaner on.
- OFF position turns vacuum cleaner off.

Handle Adjustment

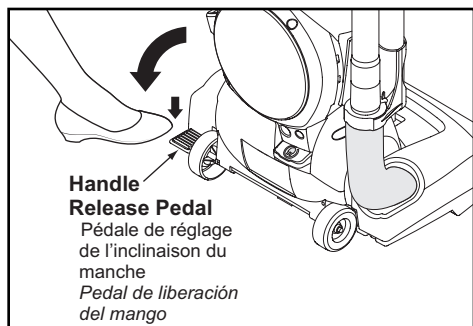

- Step on handle release pedal to change handle position.
- Move vacuum cleaner to upright position for storage and tool use.
- Move vacuum cleaner to middle position for normal use.
- Use low position for cleaning under furniture.

Using Tools

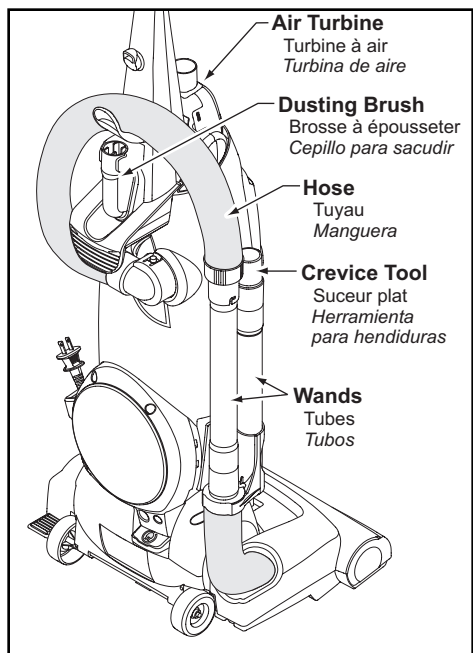

CAUTION

Agitator rotates when using tools, use care to ensure that nothing comes into contact with agitator.

- Remove wand from short hose by twisting and pulling up.
- The tools can be attached to hose, wand(s) or crevice tool.
- **DO NOT** overextend your reach with hose as it could tip vacuum cleaner.
- To prevent tipping of vacuum cleaner, use hose ring mount when cleaning areas below upper cord hook with the tools.

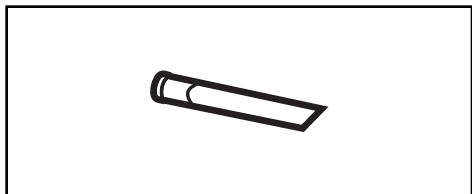

- The Crevice Tool may be used on the following items:
 - Furniture
 - Cushions
 - Drapes
 - Stairs
 - Walls

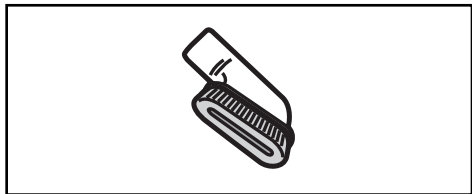

- The Combination Brush may be used on the following items:
 - Furniture
 - Drapes
 - Stairs
 - Walls

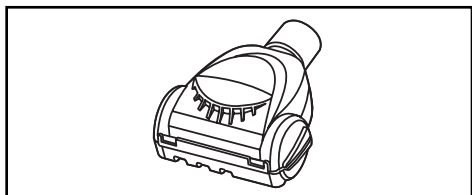

- The Air Turbine may be used on the following items:
 - Furniture
 - Stairs

Note: Always clean tools before using.

ROUTINE CARE OF VACUUM CLEANER

Performing the following tasks will keep your new Panasonic vacuum cleaner operating at peak performance levels and will ensure these high levels for years to come. Check the **BEFORE REQUESTING SERVICE** section in this manual for recommendations on performing some of these tasks to help solve various problems that may occur.

Changing Dust Bag

Always operate vacuum cleaner with genuine Panasonic Type U3 Standard or U6 Electrostatic dust bags installed. Panasonic dust bags may be purchased through any authorized Panasonic dealer or ordered from service company.

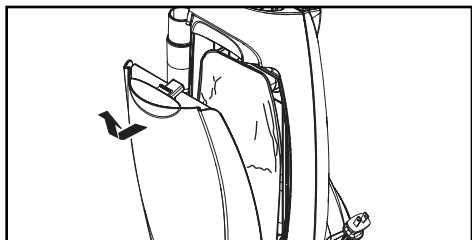

- Pull outward on dust cover grip to remove the dust cover.

Changing Dust Bag

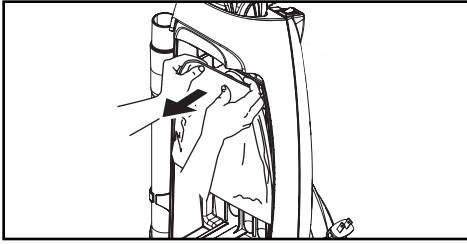

- Remove dust bag by grasping cardboard portion and pulling out.

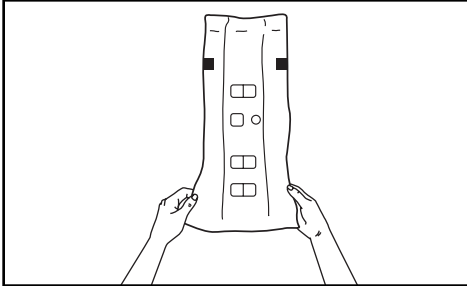

- Spread out new dust bag, taking care not to tear bag.

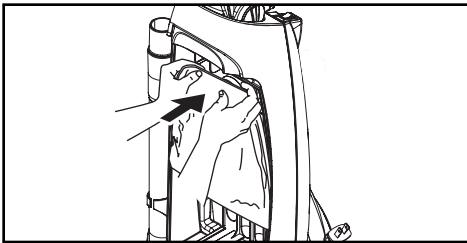

- Attach new dust bag onto bag holder by holding cardboard portion and pushing back.

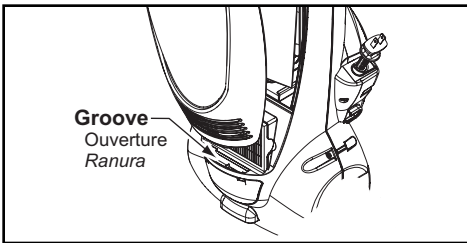

- Reinsert tab on end of dust cover into groove on dust compartment to allow cover to rotate closed.

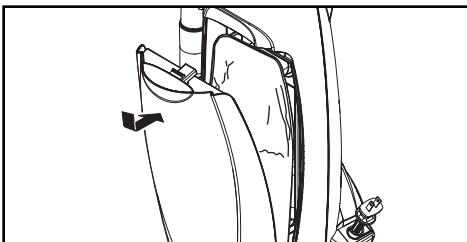

- Rotate dust cover up into closed position and press into place without pinching dust bag.

Cleaning Secondary Foam Filter

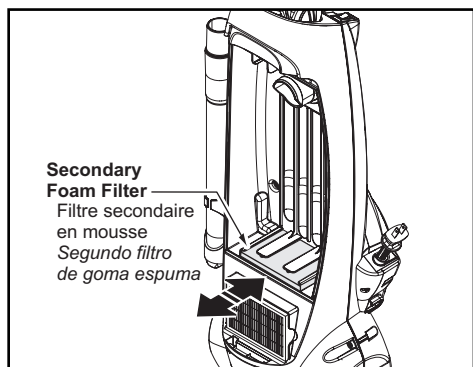

- Secondary foam filter protects motor.
- Check filter when installing a new dust bag.
- If dirty, pull filter from bottom of dust compartment and clean by rinsing in water.
- When dry, slide filter back into place.
- Ensure filter is fully inserted under plastic rib projections.

Replacing HEPA Exhaust Filter

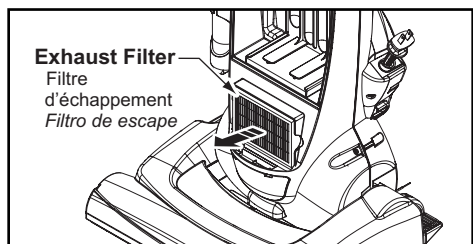

- The HEPA exhaust filter removes dirt from recirculated air.
- Check filter when installing a new dust bag.
- If dirty, remove exhaust filter cartridge.
- Insert new exhaust filter cartridge. **DO NOT CLEAN WITH WATER***

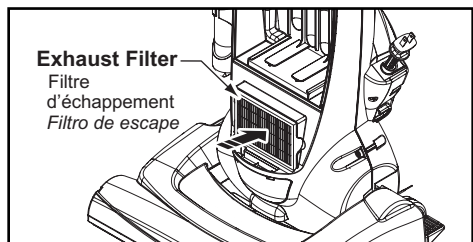

- Place filter in frame and install in dust cover. For proper operation the white side must face dust cover grill.

*Filter cannot be cleaned and should be replaced at least once each year.

! WARNING Electrical Shock or Personal Injury Hazard

Disconnect the electrical supply before servicing or cleaning the vacuum cleaner. Failure to do so could result in electrical shock or personal injury from vacuum cleaner suddenly starting.

Removing and Installing Lower Plate

Locking Tabs

Loquets de sûreté
Lengüetas de cierre

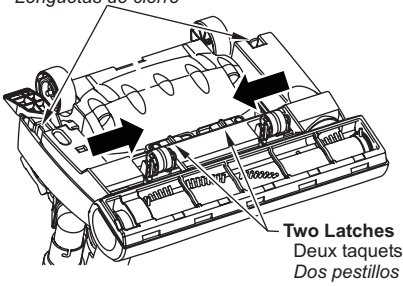

- **Before servicing any parts, disconnect vacuum cleaner from electrical outlet.**
- **Always place paper under nozzle whenever lower plate is removed to protect floor.**
- **Place handle in upright position and turn vacuum cleaner over to expose lower plate.**
- **Release lower plate by pressing two (2) latches and two (2) locking tabs inward as shown.**
- **Remove lower plate and remove any residue that may exist in belt area.**
- **Reinstall lower plate by hooking front end of lower plate into slots on front of nozzle housing.**
- **Press lower plate until locking tabs snap into place then push the two (2) latches outward.**

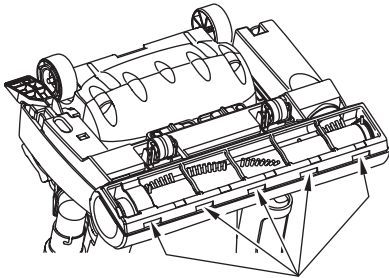

Tabs
Loquets
Lengüetas

Locking Tabs

Loquets de sûreté
Lengüetas de cierre

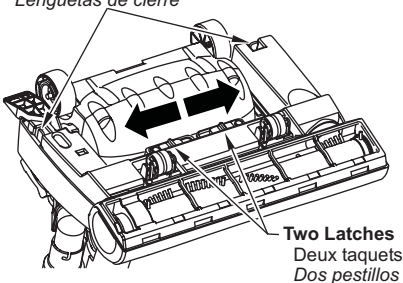

Replacing Belt

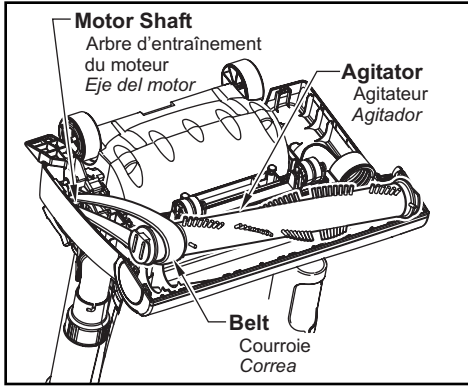

- Remove lower plate.
- Remove agitator by carefully lifting out.
- Remove worn or broken belt.
- Loop new belt (**Panasonic Type UB8 only**) around motor shaft and belt pulley; see illustration for correct belt routing.
- Reinstall agitator back into nozzle housing grooves.
- After reinstalling the agitator, turn it by hand to make sure that belt is not twisted or pinched and that all rotating parts turn freely.
- Reinstall lower plate.

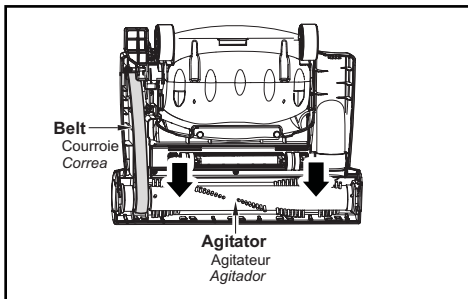
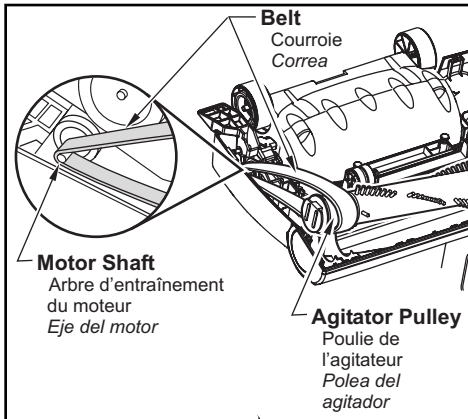

Replacing Headlight Bulb

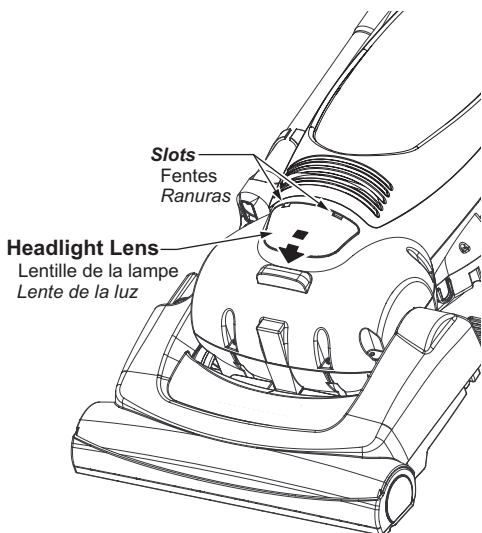

- **Disconnect power cord from electrical outlet. Lower body to lay the vacuum cleaner flat.**
- **Pry out light lens at slots by inserting screwdriver into slot, pushing down on the lens and rotating the screwdriver handle toward unit.**
- **Remove the light bulb by pulling straight out.**
- **To replace the light bulb carefully insert securely into slot. Replace lens cover.**

CAUTION

Do not use a bulb rated over 9W (13V). During extended use, heat from the bulb could overheat surrounding plastic parts.

- **Replace lens cover by inserting bottom tab of lens into slot then applying pressure to top tabs.**
- **A “popping” sound indicates lens is snapped properly in place.**

Replacing Agitator

Base Plate Belt Guard

Base Plate Belt Guard
*Protector de la correa
de la placa de la base*

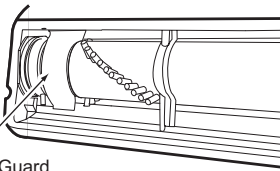

- Turn the vacuum cleaner over to check for worn brushes.
- When brushes are worn to the level of the base belt guard, replace the agitator.
- Remove lower plate and agitator.
- Position belt over belt pulley on the new agitator.
- Reinstall agitator and lower plate.

Cleaning Agitator

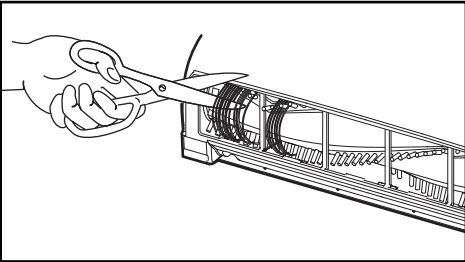

- Clean agitator after every five uses and every time the belt is replaced.
- Remove lower plate.
- Cut off any carpet pile and lint entangled around agitator with a pair of scissors.
- Remove agitator.
- Remove any string or debris located on the end caps.
- Reinstall agitator and lower plate.

Cleaning Exterior

- **Unplug cord from wall outlet.**
- **Clean exterior using a clean, soft cloth that has been dipped in a solution of mild liquid detergent and water and wrung dry.**
- **DO NOT drip water on vacuum cleaner, wipe dry after cleaning.**
- **DO NOT clean tools in dishwasher or clothes washer.**
- **Wash tools in warm, soapy water, rinse and air dry.**
- **DO NOT use tools if they are wet.**

Removing Clogs



WARNING Electrical Shock or Personal Injury Hazard

Disconnect the electrical supply before servicing or cleaning the vacuum cleaner. Failure to do so could result in electrical shock or personal injury from vacuum cleaner suddenly starting.

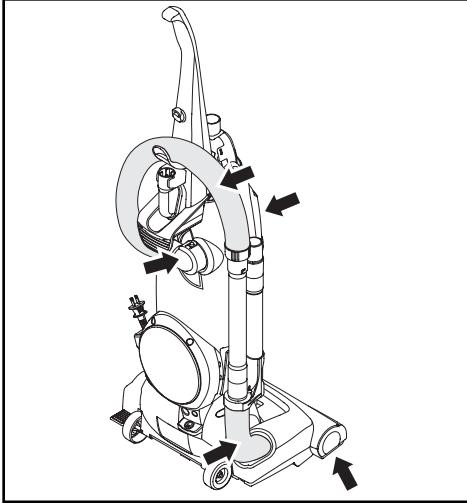

For best cleaning results, keep the airflow passage clear.

- Unplug vacuum cleaner.
- Check each indicated area occasionally for clogs.
- Inspect hose end and clear any obstructions.
- Reinstall hose and lower plate.
- While running the vacuum cleaner with the hose disconnected, stretch the hose in and out to remove the clog.
- If the clog still exists, turn the vacuum cleaner OFF and unplug the power cord.
- Turn the vacuum cleaner over, exposing the underside.
- Remove the lower plate. Remove the short nozzle hose from the housing by lifting it straight up.
- Inspect the hose end and clear it of any obstructions. Reinstall the short nozzle hose and lower plate.

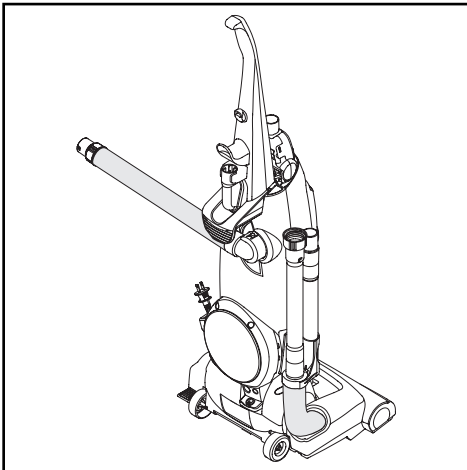

BEFORE REQUESTING SERVICE



WARNING Electrical Shock or Personal Injury Hazard

Disconnect the electrical supply before servicing or cleaning the vacuum cleaner. Failure to do so could result in electrical shock or personal injury from vacuum cleaner suddenly starting.

Review this chart to find do-it-yourself solutions for minor performance problems. Any service needed, other than those described in these Operating Instructions, should be performed by an authorized service representative.

PROBLEM	POSSIBLE CAUSE	POSSIBLE SOLUTION
Vacuum cleaner will not run.	<ol style="list-style-type: none"> 1. Unplugged at wall outlet. 2. ON-OFF switch not turned on. 3. Tripped circuit breaker/blown fuse at household service panel. 	<ol style="list-style-type: none"> 1. Plug in firmly. Push ON-OFF switch to On. 2. Push ON-OFF switch to ON. 3. Reset circuit breaker or replace fuse.
Poor job of dirt pickup.	<ol style="list-style-type: none"> 1. Full or clogged dust bag. 2. Broken belt. 3. Clogged hose or nozzle. 4. Hose not inserted fully. 5. Worn agitator. 6. Dust cover improperly installed. 	<ol style="list-style-type: none"> 1. Change bag. 2. Replace belt. 3. Clean hose or nozzle area. 4. Insert hose. 5. Replace agitator. 6. Properly install dust cover.
Dust escapes the paper bag.	<ol style="list-style-type: none"> 1. Bag improperly installed. 2. Bag torn. 	<ol style="list-style-type: none"> 1. Properly install bag. 2. Replace bag.

WARRANTY

Panasonic Vacuum Cleaner Limited Warranty (United States)

Panasonic Consumer Electronics Company (collectively referred to as "the warrantor") will repair this product with new or refurbished parts free of charge, in the U.S.A. or Puerto Rico for one (1) year from the date of original purchase in the event of a defect in materials or workmanship.

This Limited Warranty Excludes both Labor and Parts for the following items which require normal replacement: Disposable Dust Bag, Filters, Belts, Light Bulbs, Agitator Brushes and Batteries (if supplied).

Carry-in or mail-in service in the U.S.A. can be obtained during the warranty period by contacting a Panasonic Services Company (PASC) Factory Servicenter listed in the Servicenter Directory. Or call, toll-free, 1-800-211-PANA (7262) to locate a PASC Authorized Servicenter. Carry-in or mail-in service in Puerto Rico can be obtained during the warranty period by calling the local Panasonic Sales Company telephone number listed in the Servicenter Directory.

This warranty is extended only to the original purchaser. A purchase receipt or other proof of date of original purchase will be required before warranty performance is rendered.

This warranty only covers failures due to defects in materials and workmanship which occur during normal use and does not cover damages which occur in shipment, or failures which are caused by products not supplied by the warrantor, or failures which result from accident, misuse, abuse, neglect, mishandling, misapplication, faulty installation, improper operation or maintenance, alteration, modification, power line surge, improper voltage supply, lightning damage, commercial use such as hotel, office, restaurant or other business or rental use of the product, or service by anyone other than a PASC Authorized Servicenter, or damage that is attributable to acts of God.

LIMITS AND EXCLUSIONS:

There are no express warranties except as listed above.

THE WARRANTOR SHALL NOT BE LIABLE FOR INCIDENTAL OR CONSEQUENTIAL DAMAGES RESULTING FROM THE USE OF THIS PRODUCT, OR ARISING OUT OF ANY BREACH OF THIS WARRANTY. ALL EXPRESS AND IMPLIED WARRANTIES, INCLUDING THE WARRANTIES OF MERCHANTABILITY AND FITNESS FOR A PARTICULAR PURPOSE, ARE LIMITED TO THE APPLICABLE WARRANTY PERIOD SET FORTH ABOVE.

Some states do not allow the exclusion or limitation of incidental or consequential damages, or limitations on how long an implied warranty lasts, so the above exclusions or limitations may not apply to you.

This warranty gives you specific legal rights and you may also have other rights which vary from state to state. If a problem with this product develops during or after the warranty period, you may contact your dealer or Servicenter. If the problem is not handled to your satisfaction, then write to the Consumer Affairs Department at the listed address on the back cover.

WARRANTY

Panasonic Canada Inc.

PANASONIC PRODUCT - LIMITED WARRANTY

Panasonic Canada Inc. warrants this product to be free from defects in material and workmanship and agrees to remedy any such defect for a period as stated below from the date of original purchase.

Vacuum Cleaner - One (1) year, parts and labour

LIMITATIONS AND EXCLUSIONS

This warranty does not apply to products purchased outside Canada or to any product which has been improperly installed, subjected to usage for which the product was not designed, misused or abused, damaged during shipping, or which has been altered or repaired in any way that affects the reliability or detracts from the performance, nor does it cover any product which is used commercially. Parts such as disposable dust bags, filters, belts, light bulbs and agitator brushes are also excluded from coverage under this warranty. A purchase receipt or other proof of date of original purchase is required before warranty service is performed.

THIS EXPRESS, LIMITED WARRANTY IS IN LIEU OF ALL OTHER WARRANTIES, EXPRESS OR IMPLIED, INCLUDING ANY IMPLIED WARRANTIES OF MERCHANTABILITY AND FITNESS FOR A PARTICULAR PURPOSE. IN NO EVENT WILL PANASONIC CANADA INC. BE LIABLE FOR ANY SPECIAL, INDIRECT OR CONSEQUENTIAL DAMAGES.

In certain instances, some jurisdictions do not allow the exclusion or limitation of incidental or consequential damages, or the exclusion of implied warranties, so the above limitations and exclusions may not be applicable.

WARRANTY SERVICE

FOR PRODUCT OPERATION ASSISTANCE, please contact:

Our Customer Care Centre:	Telephone #:	(905) 624-5505
	1-800 #:	1-800-561-5505
	Fax #:	(905) 238-2360
	Email link:	"Contact Us" on www.panasonic.ca

FOR PRODUCT REPAIRS, please locate your nearest Authorized Servicentre at www.panasonic.ca :

Link : "ServicentresTM locator" under "Customer support"

IF YOU SHIP THE PRODUCT TO A SERVICENTRE

Carefully pack and send prepaid, adequately insured and preferably in the original carton.
Include details of the defect claimed, and proof of date of original purchase.

WHAT TO DO WHEN SERVICE IS NEEDED

If your Panasonic Vacuum Cleaner needs service, look in the Yellow Pages of the telephone book under HOME APPLIANCE SERVICE for your nearest Panasonic Services Company ("PASC") Factory Servicenter, or PASC authorized Servicenter, or call, 1-800-211-PANA (7262) tollfree to find a convenient Servicenter. **DO NOT send the product to the Executive or Regional Sales offices. They are NOT equipped to make repairs.**

If you ship the product

Carefully pack and send it prepaid, adequately insured and preferably in the original carton. Attach a postage-paid letter to the outside of the carton, which contains a description of your complaint. **DO NOT send the product to the Executive or Regional Sales Offices. They are NOT equipped to make repairs.**

**PANASONIC CONSUMER ELECTRONICS COMPANY
DIVISION OF MATSUSHITA ELECTRIC CORPORATION OF AMERICA**

One Panasonic Way
Secaucus, New Jersey 07094
World Wide Web Address
<http://www.panasonic.com>

What to do when service is needed Service après-vente (Canada)

WARRANTY SERVICE

For product operation and information assistance, please contact your Dealer or our Customer Care Centre at:

Telephone #: (905) 624-5505 or 1-800-561-5505 Fax #: (905) 238-2360 Web: www.panasonic.ca

For product repairs, please contact one of the following:

- Your Dealer who will inform you of an authorized Servicentre nearest you.
- Our Customer Care Centre at (905) 624-5505 or www.panasonic.ca
- A Panasonic Factory Servicentre listed on the warranty page.

RÉPARATION SOUS GARANTIE

Pour de l'aide sur le fonctionnement de l'appareil ou pour toute demande d'information, veuillez contacter votre détaillant ou notre service à la clientèle au :

N° de téléphone : (905) 624-5505 N° de télécopieur : (905) 238-2360 Site Internet : www.panasonic.ca

Pour la réparation des appareils, veuillez consulter :

- votre détaillant, lequel pourra vous renseigner sur le centre de service agréé le plus près de votre domicile ;
- notre service à la clientèle au (905) 624-5505 ou www.panasonic.ca;
- un de nos centres de service indiqué sur la page de garantie.

Quando necesita servicio

Si su aspiradora Panasonic necesita servicio, busque el Centro de Servicio Panasonic o un Centro de Servicio PASC autorizado más cercano bajo "Servicio de Electrodomésticos" en las páginas amarillas de la guía de teléfonos o llame gratis al 1-800-211-PANA (7262) para encontrar un centro de servicio conveniente. No mande el producto a las Executive o Regional Sales Offices. No están equipadas para arreglar estos productos.

Si manda el producto

Empaquete con cuidado en el cartón original si posible y mándelo prepagado y con seguro suficiente. Ponga una carta con sellos en la que describe su problema con el producto en el exterior del cartón. No mande el producto a las Executive o Regional Sales Offices. No están equipadas para arreglar estos productos.

**PANAMEX COMPANY
DIVISION OF PANASONIC CORPORATION OF NORTH AMERICA**

One Panasonic Way
Secaucus, New Jersey 07094
World Wide Web Address
<http://www.panasonic.com>