

This Owner's Manual is provided and hosted by Appliance Factory Parts.

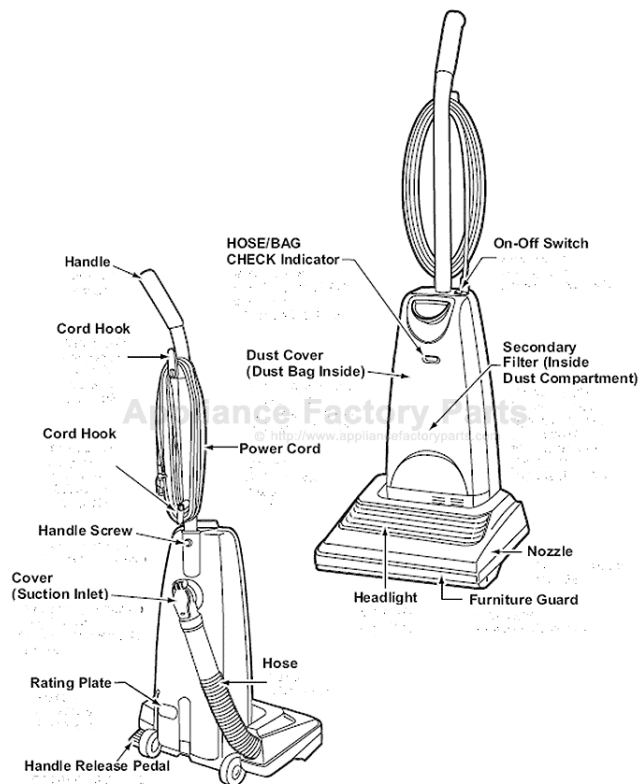

PANASONIC MC-UG585 Owner's Manual

[Shop genuine replacement parts for PANASONIC
MC-UG585](#)



[Find Your PANASONIC Vacuum Cleaner Parts - Select From 605 Models](#)

----- Manual continues below -----

Panasonic®

VACUUM CLEANER

Aspirateur

Aspiradora

MC-UG585

Operating Instructions

Manuel d'utilisation

Instrucciones de operación

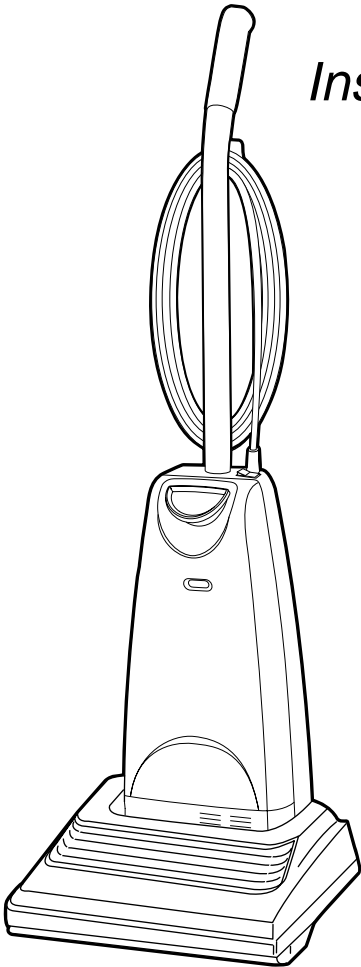

**Before operating your vacuum cleaner,
please read these instructions completely.**

Avant d'utiliser l'appareil, il est recommandé
de lire attentivement ce manuel.

*Antes de usar su aspiradora, lea
completamente estas instrucciones por favor.*

CONSUMER INFORMATION

Please read **IMPORTANT SAFETY INSTRUCTIONS** on page 5 before use. Read and understand all instructions.

TO OUR VALUED CUSTOMER

We are very pleased to welcome you to the Panasonic family of products. Thank you for purchasing this product. Our intent is that you become one of our many satisfied customers.

Proper assembly and safe use of your vacuum cleaner are your responsibilities. Your vacuum cleaner is intended only for household use. The vacuum cleaner should be stored in a dry, indoor area. Read the Operating Instructions carefully for important use and safety information.

Special care is required when vacuuming certain types of carpet or floor covering. Always check the carpet or floor covering manufacturer's recommended cleaning instructions before vacuuming.

PLEASE PAY CLOSE ATTENTION TO ALL WARNING AND CAUTION STATEMENTS.

WARNING

WARNING statements are designed to alert you to the possibility of personal injury, loss of human life, and/or damage to the vacuum cleaner and/or personal property if the instructions given are not followed.

CAUTION

CAUTION statements are designed to alert you to the possibility of damage to the vacuum cleaner and/or personal property if the instructions given are not followed.

WARNING

TO AVOID ELECTRICAL SHOCK

Never vacuum damp or wet surfaces or liquids.
DO NOT store vacuum cleaner outdoors.
Replace worn or frayed power cord immediately.
Unplug from outlet when not in use and before servicing.

TO AVOID ACCIDENTS

Except for hand-held cleaners, keep vacuum cleaner on floor - not chairs, tables, steps, stairs, etc.
Store vacuum cleaner promptly after each use to prevent accidents such as tripping over power cord or vacuum cleaner.
Use vacuum cleaner and accessories only in a manner intended by the manufacturer.
The use of an extension cord is not recommended.

Información para el consumidor

Por favor, lea "Instrucciones importantes de seguridad" en la página 7 antes de usar su aspiradora. Lea y comprenda todas las instrucciones.

A NUESTRO CONSUMIDOR ESTIMADO

Nos da mucho gusto a presentarle a la familia de productos de Panasonic. Le damos las gracias por comprar este producto. Estamos resueltos a hacerle uno de nuestros muchos consumidores satisfechos.

Montaje correcto y uso seguro de su aspiradora son sus responsabilidades. Su aspiradora está fabricada para el uso de domicilio únicamente. Debe guardar la aspiradora en un lugar seco y debajo de techo. Lea las "Instrucciones de operación" con cuidado para la información importante de uso y la información de seguridad.

Se requiere el cuidado especial cuando pasa la aspiradora sobre ciertas clases de alfombra o cubierta de piso. Siempre revise las instrucciones de la limpieza recomendada de fabricante para la alfombra o la cubierta de piso antes de pasar la aspiradora.

Preste mucha atención por favor a todos los avisos y a todas las advertencias

ADVERTENCIA

Las secciones **ADVERTENCIA** están incluidas para llamarle atención a la posibilidad de la lesión corporal, la pérdida de vida humana, y/o el daño a la aspiradora y/o el daño a las propiedades personales si las instrucciones dadas no están seguidas.

CUIDADO

Las secciones **CUIDADO** están incluidas para llamarle atención a la posibilidad del daño a la aspiradora, y/o del daño a las propiedades personales si las instrucciones dadas no están seguidas.

ADVERTENCIA

PARA EVITAR CHOQUE ELÉCTRICO

Nunca pase la aspiradora en las superficies húmedas o mojadas ni aspire los líquidos.
No mantenga la aspiradora a la intemperie.
Cambio en seguida un cordón eléctrico gastado o raído.
Desconéctela cuando lo la está usando y antes de darle servicio.

PARA EVITAR ACCIDENTES

Excepto las aspiradoras a mano, mantenga la aspiradora sobre el suelo - no sobre las sillas, las mesas, los escalones, las escaleras, etc.
Mantenga la aspiradora en un lugar seguro en seguida después de cada uso para evitar accidentes como tropiezo con cordón eléctrico o con aspiradora.
Use la aspiradora y los accesorios únicamente en manera descrita en este manual.
No recomiende un cordón eléctrico adicional.

IMPORTANT SAFETY INSTRUCTIONS

When using your vacuum cleaner, basic precautions should always be followed, including the following:

Read all instructions in this manual before assembling or using your vacuum cleaner.

WARNING To reduce the risk of fire, electrical shock, injury:

1. **Use** your vacuum cleaner only as described in this manual. Use only with Panasonic recommended attachments.
2. **Disconnect** electrical supply before servicing or cleaning out the brush area. Failure to do so could result in the brush unexpectedly starting, causing personal injury from moving parts.
3. **Do not** leave vacuum cleaner when plugged in. Unplug from outlet when not in use and before servicing.
4. **To reduce** the risk of electrical shock - Do not use outdoors or on wet surfaces.
5. **Do not** allow to be used as a toy. Close attention is necessary when used by or near children.
6. **Do not** use with a damaged cord or plug. If vacuum cleaner is not working as it should, has been dropped, damaged, left outdoors, or dropped in water, return it to a Panasonic Service Center.
7. **Do not** pull or carry by cord, use cord as a handle, close a door on cord, or pull cord around sharp edges or corners. Do not run vacuum cleaner over cord. Keep cord away from heated surfaces.
8. **Do not** unplug by pulling on cord. To unplug, grasp the plug, not the cord.
9. **Do not** handle plug or vacuum cleaner with wet hands.
10. **Do not** put any objects into openings.
11. **Do not** use with any opening blocked; keep free of dust, lint, hair, and anything that may reduce air flow.
12. **Keep** hair, loose clothing, fingers, and all parts of body away from openings and moving parts.
13. **Turn off** all controls before unplugging.
14. **Use** extra care when cleaning on stairs. Do not put on chairs, tables, etc. Keep on floor.
15. **Do not** use vacuum cleaner to pick up flammable or combustible liquids (gasoline, cleaning fluid, perfumes, etc.), or use in areas where they may be present. The fumes from these substances can create a fire hazard or explosion.
16. **Do not** pick up anything that is burning or smoking, such as cigarettes, matches, or hot ashes.
17. **Do not** use vacuum cleaner without dust bag and/or filters in place.
18. **You are** responsible for making sure that your vacuum cleaner is not used by anyone unable to operate it properly.

SAVE THESE INSTRUCTIONS

THIS VACUUM CLEANER IS INTENDED FOR HOUSEHOLD USE ONLY

NOTE: Before you plug in your Panasonic vacuum cleaner, make sure that the voltage indicated on the rating plate located at the back of the vacuum cleaner is the same as your local electrical supply.

Importantes mesures de sécurité

Afin de réduire les risques d'incendie, de chocs électriques ou de lésions corporelles.

Veillez lire toutes les instructions de ce manuel avant d'assembler votre aspirateur.

AVERTISSEMENT

Il est important de suivre des précautions générales lors de l'utilisation de l'aspirateur, comprenant celles énumérées ci-dessous:

1. **Utiliser** l'aspirateur seulement de la manière décrite dans ce manuel. Utiliser seulement les accessoires recommandés par Panasonic.
2. **Débrancher** l'alimentation électrique avant de réparer ou de nettoyer les alentours de la brosse. La non-observation de cette consigne pourrait engendrer un choc électrique ou le démarrage soudain et inattendu de la brosse.
3. **Ne pas** laisser l'aspirateur branché. Débrancher de la prise murale lorsque l'aspirateur n'est pas en utilisation et avant de le réparer.
4. **Afin** de réduire les risques de chocs électriques - Ne pas l'utiliser à l'extérieur ou sur des surfaces mouillées.
5. **Ne pas** permettre l'utilisation de l'aspirateur comme un jouet. Il est nécessaire de surveiller de près lors de proximité aux enfants lors de son utilisation.
6. **Ne pas** utiliser si le cordon et/ou la fiche sont endommagés. Si l'aspirateur ne fonctionne pas correctement, s'il est tombé, endommagé, laissé dehors ou tombé dans l'eau, il est nécessaire de l'apporter à un centre de service.
7. **Ne pas** tirer ou porter l'aspirateur par le cordon, ni utiliser le cordon en tant que manche, ni fermer une porte sur le cordon, ni tirer le cordon autour de coins aigus. **Ne pas** passer l'aspirateur sur le cordon. Ne pas laisser le cordon à proximité de surface chauffante.
8. **Ne pas** débrancher en tirant sur le cordon. Saisir la fiche, et non le cordon pour débrancher.
9. **Ne pas** toucher ni la fiche, ni l'aspirateur avec les mains mouillées.
10. **Ne** mettre aucun objet dans les ouvertures.
11. **Ne pas** utiliser si une ouverture est obstruée. Garder libre de poussière, peluche, poil ou tout autre matériel qui pourrait réduire le passage d'air.
12. **Éloigner** les cheveux, vêtements, doigts et toute autre partie du corps des ouvertures et des pièces en mouvement.
13. **Éteindre** tout contrôle avant de débrancher.
14. **Prendre des précautions supplémentaires lors de nettoyage des escaliers. Ne pas mettre sur chaises, tables, etc. mais le garder au niveau du sol.**
15. **Ne pas** utiliser l'aspirateur pour aspirer des liquides ininflammables ou combustibles (essence, liquide nettoyant, parfums etc.) ni dans des endroits où ils pourraient être présents. Les vapeurs de ces produits pourraient créer un danger d'incendie ou d'explosion.
16. **Ne pas** ramasser les objets en combustion ou émettant de la fumée tels que les cigarettes, allumettes ou cendres brûlantes.
17. **Ne pas** utiliser l'aspirateur sans sac à poussière et/ou de filtre en place.
18. **Débrancher** avant d'installer le Air Turbine (le cas échéant). Il est de votre responsabilité de vous assurer que votre aspirateur ne soit pas utilisé par des personnes incompetentes à son utilisation.

Conserver ce manuel d'utilisation

Cet aspirateur est destiné à un usage domestique seulement.

Remarque: Avant de brancher l'aspirateur, vérifier que la tension du secteur corresponde à celle de l'appareil, indiquée sur la plaque signalétique à l'arrière de l'appareil.

TABLE OF CONTENTS

| | |
|---|--------|
| CONSUMER INFORMATION | 2 |
| IMPORTANT SAFETY INSTRUCTIONS | 5 |
| PARTS IDENTIFICATION | 10 |
| FEATURE CHART | 11 |
| ASSEMBLY | 12 |
| Attaching Handle | 12 |
| FEATURES | 14 |
| Using Cord Hook | 14 |
| Automatic Self Adjusting Nozzle | 14 |
| Edge Cleaning | 14 |
| Vac Gauge | 16 |
| Thermal Protector | 16 |
| TO OPERATE VACUUM CLEANER | 18 |
| Power Cord | 18 |
| ON-OFF Switch | 18 |
| Handle Adjustments | 20 |
| ROUTINE CARE OF VACUUM CLEANER | 22 |
| Replacing Secondary HEPA Filter | 22 |
| Changing Dust Bag | 22, 24 |
| Removing and Installing Lower Plate | 26 |
| Replacing Headlight Bulb | 28 |
| Replacing Belt | 28, 30 |
| Cleaning Agitator | 30 |
| Replacing Brushes | 32 |
| Agitator Assembly | 34 |
| Cleaning Exterior and Tools | 34 |
| Removing Clogs | 36 |
| BEFORE REQUESTING SERVICE | 38 |
| WARRANTY | 41, 42 |
| WHAT TO DO WHEN SERVICE IS NEEDED | 48 |

Table des matières

Tabla de contenido

| | |
|---|---|
| Renseignements importants 3 | <i>Información para el consumidor</i> 4 |
| Importantes mesures de sécurité 6 | <i>Instrucciones importantes de seguridad</i> 7 |
| Nomenclature 10 | <i>Identificación de piezas</i> 10 |
| Tableau des caractéristiques.....11 | <i>Diagram de características</i> 11 |
| Assemblage 13 | <i>Montaje</i> 13 |
| Montage du manche 13 | <i>Colocación del mango</i> 13 |
| Caractéristiques 15 | <i>Características</i> 15 |
| Crochet de rangement du cordon15 | <i>Uso del sujetador del cordón</i> 15 |
| Tête d'aspiration autoréglable 15 | <i>Boquilla de ajuste automático</i> 15 |
| Nettoyage latéral 15 | <i>Limpieza para orillas</i> 15 |
| Indicateur du sac à poussière17 | <i>Indicador de aspiración</i> 17 |
| Protecteur thermique 17 | <i>Protector termal</i> 17 |
| Fonctionnement 19 | <i>Para operar la aspiradora</i> 19 |
| Cordon d'alimentation 19 | <i>Cordón eléctrico</i> 19 |
| Interrupteur 19 | <i>Control ON-OFF</i> 19 |
| Réglage de l'inclinaison du manche 21 | <i>Ajustes del mango</i> 21 |
| Entretien de l'aspirateur 23 | <i>Cuidado de rutina de la aspiradora</i> 23 |
| Remplacement du filtre secondaire de type HEPA..... 23 | <i>Cambiar el filtro de HEPA secundario</i> 23 |
| Remplacement du sac à poussière 23, 25 | <i>Cambio de la bolsa de polvo</i> 23-25 |
| Enlèvement et installation de la plaque inférieure 27 | <i>Cambiar e Insertar la base inferior</i> 27 |
| Remplacement de l'ampoule de la lampe.....29 | <i>Cambio de la bombilla</i> 29 |
| Remplacement de la courroie 29, 31 | <i>Cambio de la correa</i> 29, 31 |
| Nettoyage de l'agitateur 31 | <i>Limpieza del agitador</i> 31 |
| Remplacement des brosses..... 33 | <i>Cambiar los cepillos</i> 33 |
| Assemblage de l'agitateur35 | <i>Montaje de agitador</i> 35 |
| Nettoyage du boîtier et des accessoires 35 | <i>Limpieza del exterior y de las herramientas</i> 35 |
| Dégagement des obstructions 37 | <i>Limpiar los residuos de basura en los conductos</i> 37 |
| Guide de dépannage 39 | <i>Antes de pedir servicio</i> 40 |
| Garantie 43 | <i>Garantía</i> 44 |
| Service après-vente 48 | <i>Cuando necesita servicio</i> 48 |

PARTS IDENTIFICATION

Nomenclature Identificación de piezas

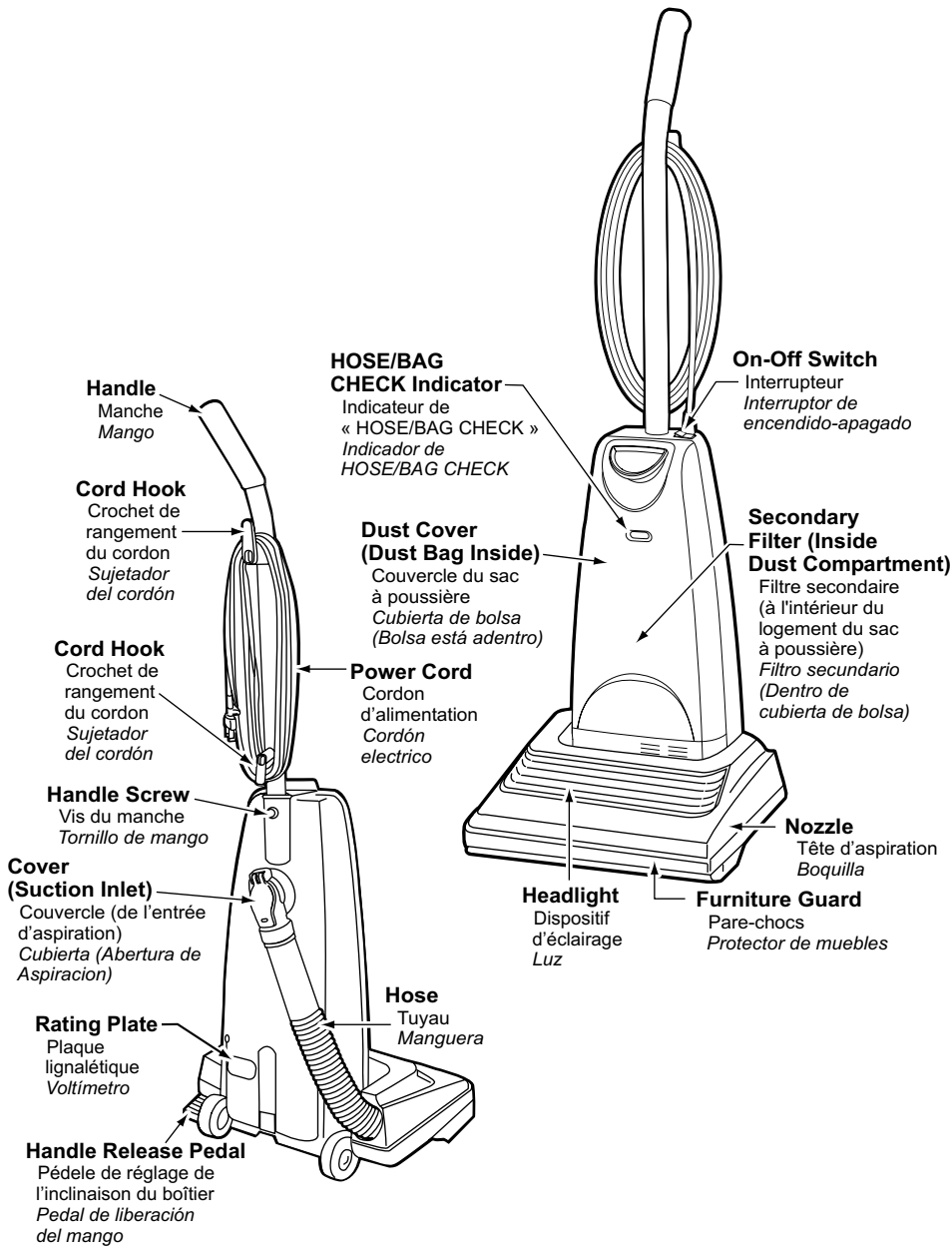

FEATURE CHART

| Power | Thermal Protector | Cord Length | Tools |
|----------------|-------------------|----------------|----------|
| 120V AC (60Hz) | Yes | 9.1 m (30 Ft.) | Optional |

Tableau des caractéristiques

| Alimentation | Protecteur thermique | Longueur du cordon | Accessoires |
|-------------------|----------------------|--------------------|-------------|
| 120 V c.a. (60Hz) | Oui | 9,1 m (30 pi) | Optionnels |

Diagrama de características

| <i>Voltaje</i> | <i>Protector termal</i> | <i>Extensión de cordón</i> | <i>Herramientas</i> |
|-------------------|-------------------------|----------------------------|---------------------|
| 120 V c.a. (60Hz) | Si | 9,1 m (30 pi) | Opcional |

ASSEMBLY

Attaching Handle

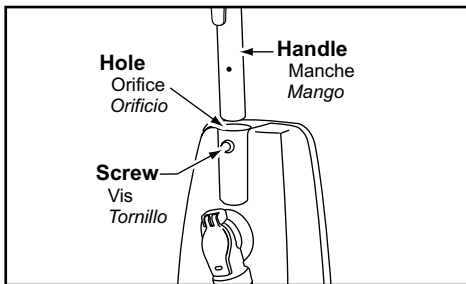

- 1)
 - **DO NOT** plug in until assembly is complete.
 - Remove handle screw.
 - Insert handle with cord hooks to the back of the vacuum cleaner.

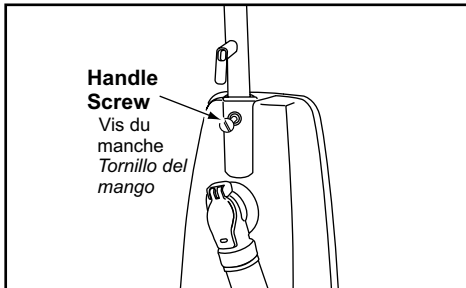

- 2)
 - Insert screw.
 - Tighten screw.

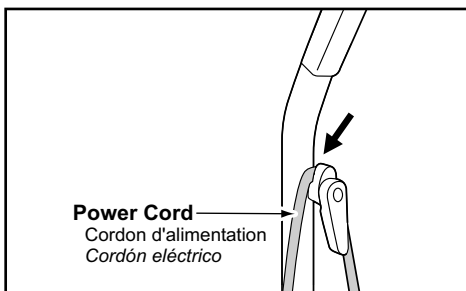

- 3)
 - Push power cord into cord clip.

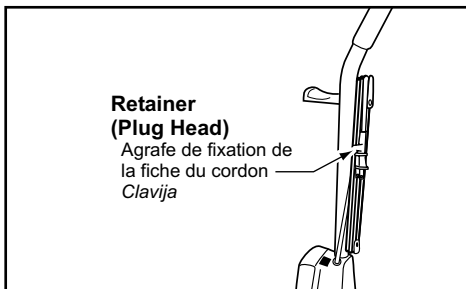

- 4)
 - Wrap power cord around cord hooks.
 - Secure retainer (plug head) to power cord.

FEATURES

Using Cord Hook

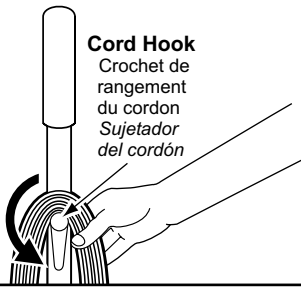

1)

- Detach plug head from power cord.
- Rotate cord hook down to release cord.

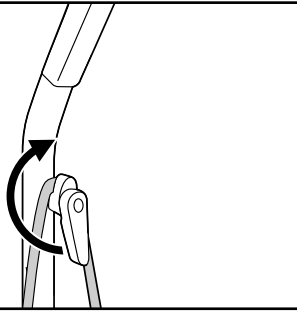

- Return the cord hook to the upright position before attempting to rewind the cord.

Automatic Self Adjusting Nozzle

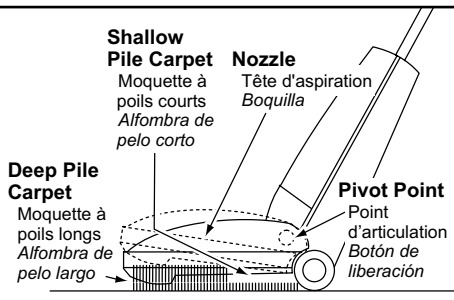

- The nozzle of your Panasonic upright vacuum cleaner automatically adjusts to any carpet pile height.
- Feature allows nozzle to float evenly over carpet pile surfaces.
- No manual adjustments required.

Edge Cleaning

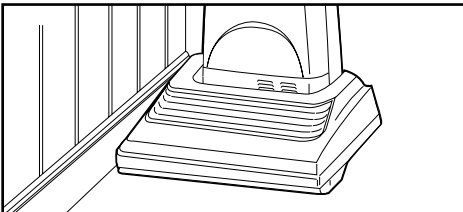

- Edge cleaning feature enables improved cleaning of carpets near walls and furniture.

Hose/Bag Check Indicator

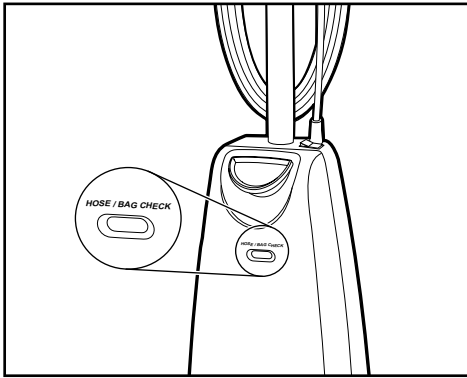

- The **BAG/ HOSE CHECK** indicator detects when dust bag needs changing or the vacuum cleaner is clogged.
- Check dust bag when indicator indicates **FULL**.
- If dust bag is full, change bag according to **CHANGING DUST BAG** section.
- If dust bag is not full, check for clogs according to **REMOVING CLOGS** section.

Thermal Protector

- If a clog prevents the normal flow of air to the motor, the thermal protector turns the motor off automatically to allow the motor to cool in order to prevent possible damage to the vacuum cleaner.
- During this time the headlight remains on.
- To correct problem, turn off and unplug vacuum cleaner, remove clogs, and/or clean/replace filters.
- Replace full bag if necessary.
- Wait approximately thirty (30) minutes, plug vacuum cleaner in, turn on to see if thermal protector has reset. Thermal protector will not reset if vacuum cleaner is not turned off even if vacuum cleaner cools down.

TO OPERATE VACUUM CLEANER

Power Cord

NOTE: To reduce the risk of electrical shock, this vacuum cleaner has a polarized plug, one blade is wider than the other. This plug will fit in a polarized outlet only one way. If the plug does not fit fully in the outlet, reverse the plug. If it still does not fit, contact a qualified electrician to install the proper outlet. **DO NOT CHANGE THE PLUG IN ANY WAY.** Only use outlets near the floor.

ON-OFF Switch

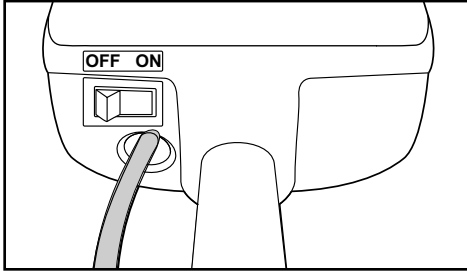

- > Ensure ON-OFF switch is OFF.
- > Plug the power cord into 120V outlet.
- > ON position turns vacuum cleaner on.
- > OFF position turns vacuum cleaner off.

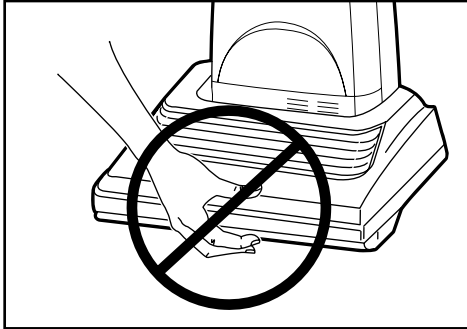

CAUTION

Moving parts! To reduce the risk of personal injury, **DO NOT** touch the agitator when vacuum cleaner is on. Contacting the agitator while it is rotating can cut, bruise or cause other injuries. Always unplug from electrical outlet before servicing. Use caution when operating near children.

Handle Adjustments

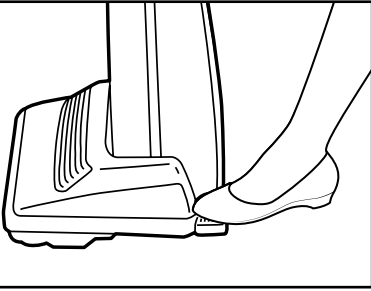

1)

- Step on handle release pedal to change handle position.

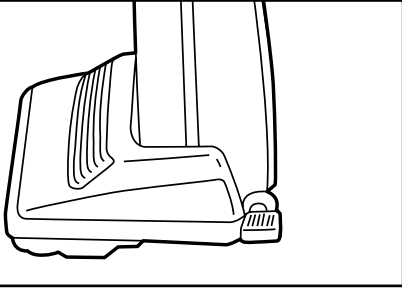

2)

- Move vacuum cleaner to upright position for storage and tool use.

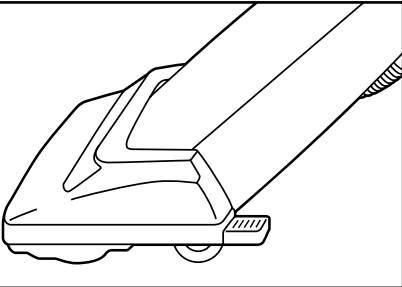

3)

- Move vacuum cleaner to middle position for normal use.

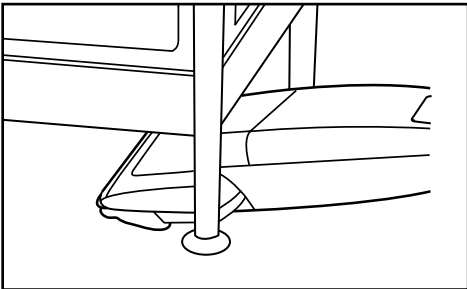

4)

- Use low position for cleaning under furniture.

ROUTINE CARE OF VACUUM CLEANER

Performing the following tasks will keep your new Panasonic vacuum cleaner operating at peak performance levels and will ensure these high levels for years to come. Check the **BEFORE REQUESTING SERVICE** section in this manual for recommendations on performing some of these tasks to help solve various problems that may occur.

Replacing Secondary HEPA Filter

Secondary HEPA Filter (White Side Up)

Filtre secondaire de type HEPA
(Côté blanc sur le dessus)
Filtro de HEPA secundario
(Blanca hacia arriba)

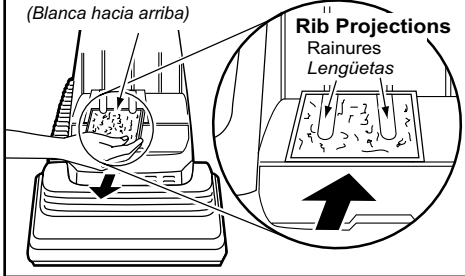

- Secondary HEPA filter protects the motor.
- Check filter when installing a new dust bag.
- If dirty, pull filter from bottom of dust compartment and replace.
- Place new filter, white side up, in dust compartment, **DO NOT CLEAN WITH WATER***.
- Ensure filter is fully inserted under plastic rib projections.

*Filter cannot be cleaned and should be replaced at least once each year.

Changing Dust Bag

Always operate vacuum cleaner with genuine Panasonic Type U12 dust bags installed. Panasonic dust bags may be purchased through any authorized Panasonic dealer or ordered from service company.

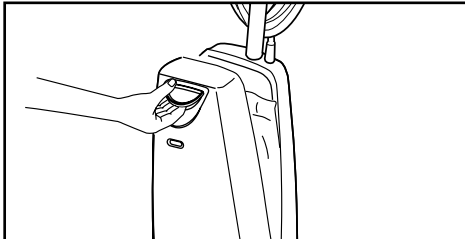

- Lift latch to release dust cover.
- Pull outward to remove dust cover.

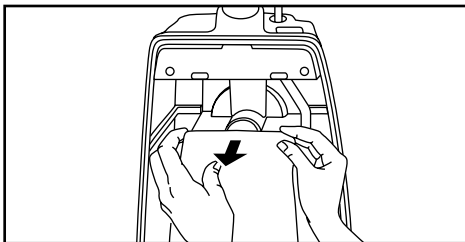

- Remove dust bag by grasping cardboard portion and pulling out.

Changing Dust Bag

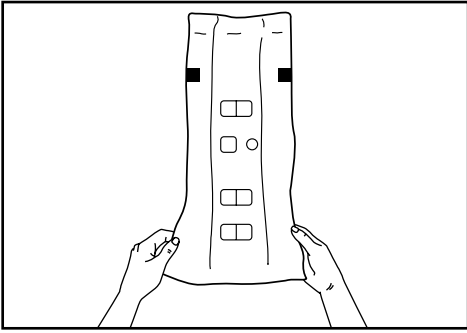

- Spread out new dust bag, taking care not to tear bag.

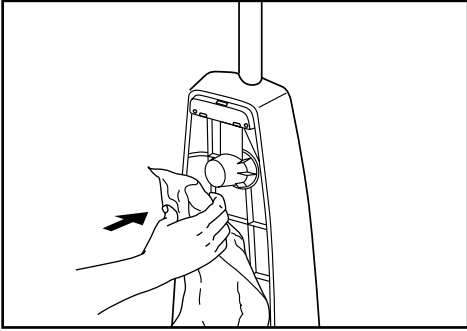

- Attach new dust bag onto bag holder by holding cardboard portion and pushing back.

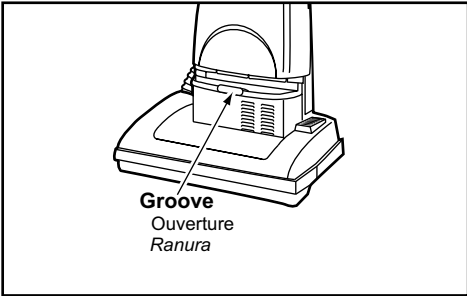

- Reinsert tab on end of dust cover into groove on dust compartment.

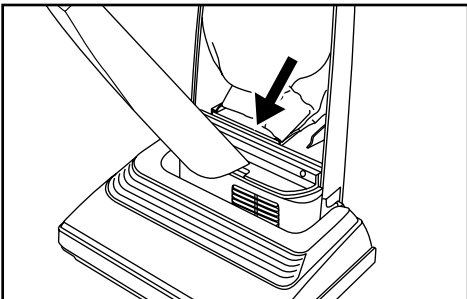

- Press dust cover into place without pinching dust bag.

! WARNING Electrical Shock or Personal Injury Hazard

Disconnect the electrical supply before servicing or cleaning the vacuum cleaner. Failure to do so could result in electrical shock or personal injury from vacuum cleaner suddenly starting.

Removing and Installing Lower Plate

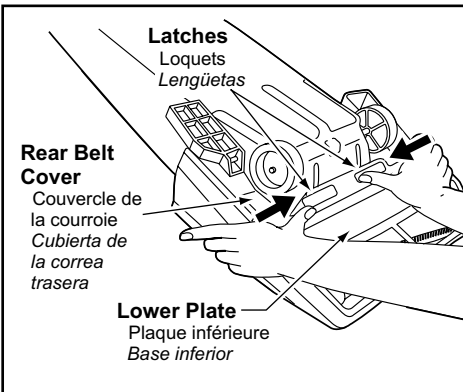

- **Before servicing any parts, disconnect vacuum cleaner from electrical outlet.**
- **Place paper under nozzle any time lower plate is removed to protect floor.**
- **Place handle in upright position and turn vacuum cleaner over to expose lower plate.**
- **Release lower plate by pressing two (2) latches inward.**
- **Remove lower plate and remove any residue that may exist in belt area.**
- **Close the rear belt cover and reinstall lower plate by hooking front end of lower plate into slots on front of nozzle housing.**
- **Make sure all wires are routed properly and not pinched.**
- **Press lower plate into place then push two (2) latches outward.**

Replacing Headlight Bulb

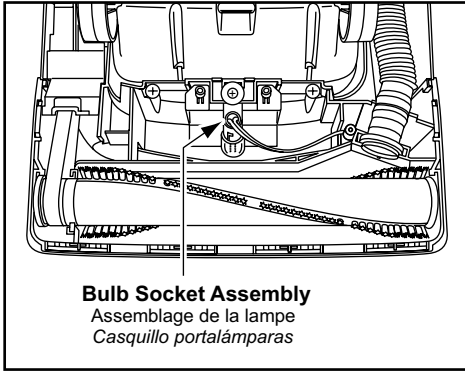

- Remove lower plate.
- Remove bulb socket screw, grasp the bulb socket assembly and pull upward while moving it back and forth.
- Remove old bulb from the bulb socket assembly by pushing in while turning counter-clockwise.
- Replace bulb by pushing in while turning clockwise.
- Only use a bulb rated 130 V AC-15 Watts or less.
- Reinstall bulb socket assembly into nozzle housing by pushing it back down into slot and reinstall bulb socket screw.
- Reinstall lower plate.

Replacing Belt

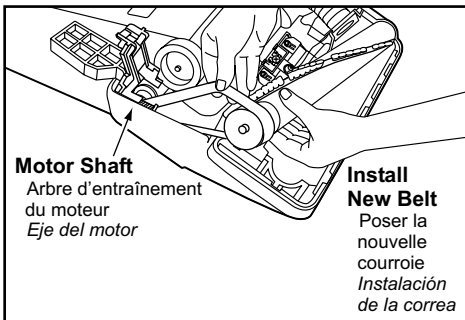
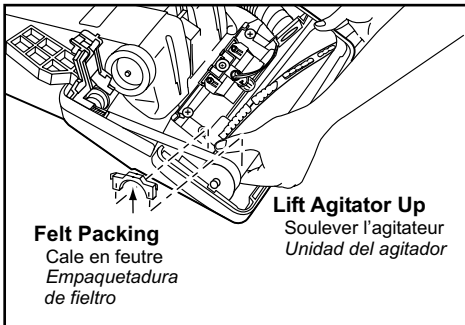

- Replace belt whenever a burning rubber smell caused by excessive slippage occurs.
- Remove lower plate.
- Lift rear belt cover and remove felt packing.
- Remove agitator by carefully lifting out.
- Remove worn or broken belt.
- Clean agitator.
- Loop new belt (Panasonic Type UB8 only) around motor shaft and agitator pulley; see illustration for correct belt routing.

Replacing Belt

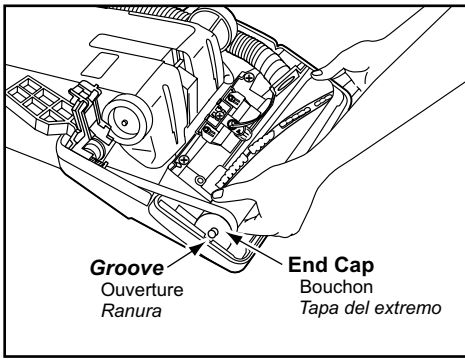

- Reinstall agitator back into nozzle housing grooves.
- Close rear belt cover and reinstall felt packing.
- After reinstalling the agitator, turn it by hand to make sure that belt is not twisted or pinched and that all rotating parts turn freely.
- Reinstall lower plate.

Cleaning Agitator

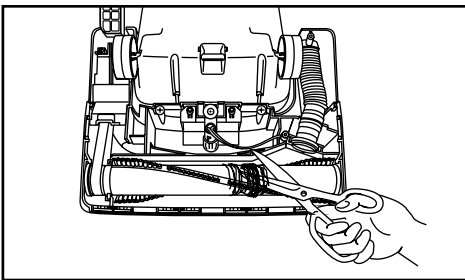

- Clean agitator after every five uses and every time the belt is replaced.
- Remove lower plate.
- Cut off any carpet pile and lint entangled around agitator with a pair of scissors.
- Remove agitator.
- Remove any string or debris located on the end caps, washers or agitator shaft.
- Reinstall agitator and lower plate.

Replacing Brushes

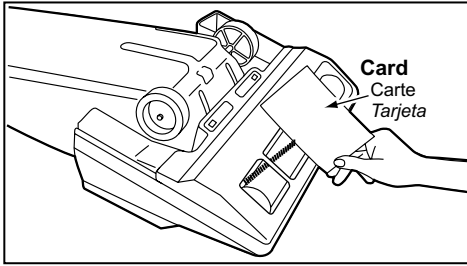

- When the bristles on the agitator are worn so that they do not touch a card held across the lower plate, the brushes should be replaced.
- Remove lower plate and agitator.

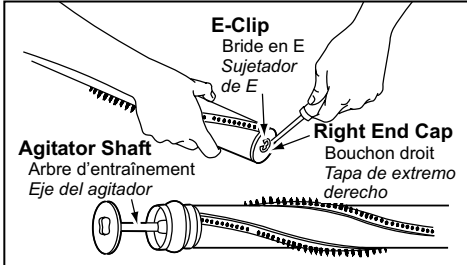

- Remove the E-clip from agitator shaft and end cap.
- Do not bend agitator shaft or lose E-clip.
- Pull agitator shaft out of agitator body.

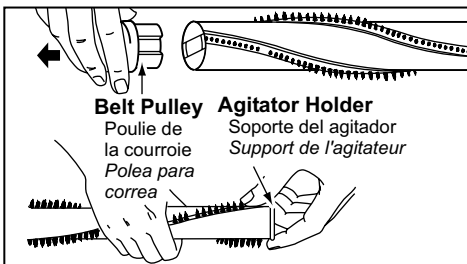

- Pull, or pry out, agitator holder and agitator pulley.
- Push each brush out of agitator body as shown.
- Install new brushes by reversing procedure.
- Reinstall agitator holder and agitator pulley completely.

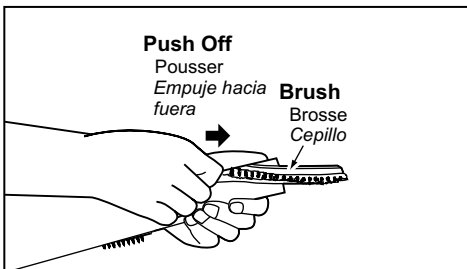

- Reinstall the agitator shaft, end cap and E-clip.
- See exploded view on page 32 for correct assembly of parts.
- Position belt over agitator pulley on the agitator.
- Reinstall agitator and lower plate.

Agitator Assembly

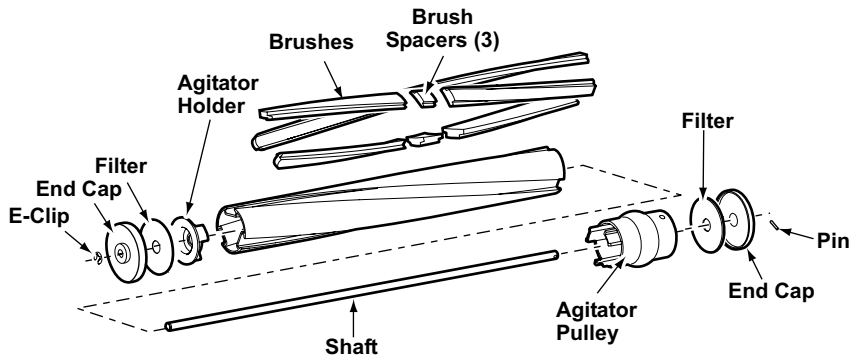

Cleaning Exterior and Tools

- Unplug cord from wall outlet.
- Clean exterior using a clean, soft cloth that has been dipped in a solution of mild liquid detergent and water and wrung dry.
- DO NOT drip water on vacuum cleaner and wipe dry after cleaning.
- DO NOT clean tools in dishwasher or clothes washer.
- Wash tools in warm soapy water, rinse and air dry.
- DO NOT use tools if they are wet.

Removing Clogs

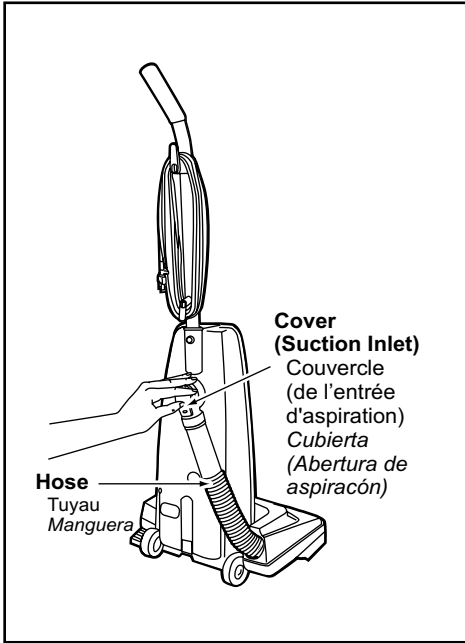

The hose located on the back of the vacuum cleaner carries the dirt from the nozzle up to the dust bag. If the hose should become clogged:

- Unplug vacuum cleaner.
- Pull open suction inlet cover and check for clogging.
- Remove lower plate.
- Remove hose from nozzle by lifting straight up.

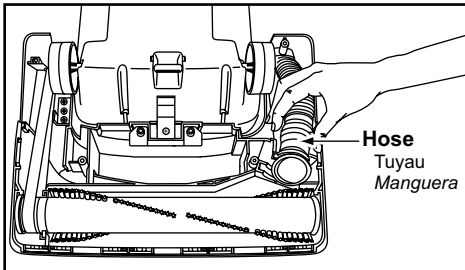

- Inspect hose end and clear any obstructions.
- Reinstall hose and lower plate.

BEFORE REQUESTING SERVICE

WARNING Electrical Shock or Personal Injury Hazard

Disconnect the electrical supply before servicing or cleaning the vacuum cleaner. Failure to do so could result in electrical shock or personal injury from vacuum cleaner suddenly starting.

Review this chart to find do-it-yourself solutions for minor performance problems. Any service needed, other than those described in these Operating Instructions, should be performed by an authorized service representative.

| PROBLEM | POSSIBLE CAUSE | POSSIBLE SOLUTION |
|-------------------------------------|--|---|
| Vacuum Cleaner will not run. | <ol style="list-style-type: none"> 1. Unplugged at wall outlet. 2. ON-OFF switch not turned on. 3. Tripped circuit breaker/blown fuse at household service panel. | <ol style="list-style-type: none"> 1. Plug in firmly. Push ON-OFF switch to On. 2. Push ON-OFF switch to ON. 3. Reset circuit breaker or replace fuse. |
| Poor job of dirt pickup. | <ol style="list-style-type: none"> 1. Full or clogged dust bag. 2. Broken belt. 3. Clogged hose or nozzle. 4. Hose not inserted fully. 5. Worn agitator. 6. Hole in hose. 7. Dust cover improperly installed. | <ol style="list-style-type: none"> 1. Change bag. 2. Replace belt. 3. Clean hose or nozzle area. 4. Insert hose. 5. Replace agitator. 6. Replace hose. 7. Properly install dust cover. |
| Dust escapes the paper bag. | <ol style="list-style-type: none"> 1. Bag improperly installed. 2. Bag torn. | <ol style="list-style-type: none"> 1. Properly install bag. 2. Replace bag. |

WARRANTY

Panasonic Platinum Series Vacuum Cleaner Limited Warranty

Panasonic Consumer Electronics Company (collectively referred to as "the warrantor") will repair this product, in the event of a defect in materials or workmanship, with new or refurbished parts free of charge, in the U.S.A. or Puerto Rico, for the length of the period indicated on the chart below, from the date of original purchase.

| | PARTS | LABOR |
|----------------------------------|----------------|---------------|
| All Parts (except motors) | Two (2) Years | Two (2) Years |
| Motors | Five (5) Years | Two (2) Years |

This Limited Warranty Excludes both Labor and Parts for the following items which require normal replacement: Disposable Dust Bag, Filters, Belts, Light Bulbs, Agitator Brushes and Batteries (if supplied).

Carry-in or mail-in service in the U.S.A. can be obtained during the warranty period by calling 1-800-211-PANA (7262) to locate a PSTC authorized service center, or you can also visit our Web Site: <http://www.panasonic.com/consumersupport>.

Carry-in or mail-in service in Puerto Rico can be obtained during the warranty period by calling the local Panasonic Sales Company telephone number listed in the Service Center Directory.

This warranty is extended only to the original purchaser. A purchase receipt or other proof of date of original purchase will be required before warranty performance is rendered.

This warranty only covers failures due to defects in materials and workmanship which occur during normal use and does not cover damages which occur in shipment, or failures which are caused by products not supplied by the warrantor, or failures which result from accident, misuse, abuse, neglect, bug infestation, mishandling, misapplication, faulty installation, improper operation or maintenance, alteration, modification, power line surge, improper voltage supply, lightning damage, commercial use such as hotel, office, restaurant or other business or rental use of the product, or service by anyone other than a PSTC authorized service center, or damage that is attributable to acts of God.

LIMITS AND EXCLUSIONS:

There are no express warranties except as listed above.

THE WARRANTOR SHALL NOT BE LIABLE FOR INCIDENTAL OR CONSEQUENTIAL DAMAGES RESULTING FROM THE USE OF THIS PRODUCT, OR ARISING OUT OF ANY BREACH OF THIS WARRANTY. ALL EXPRESS AND IMPLIED WARRANTIES, INCLUDING THE WARRANTIES OF MERCHANTABILITY AND FITNESS FOR A PARTICULAR PURPOSE, ARE LIMITED TO THE APPLICABLE WARRANTY PERIOD SET FORTH ABOVE.

Some states do not allow the exclusion or limitation of incidental or consequential damages, or limitations on how long an implied warranty lasts, so the above exclusions or limitations may not apply to you.

This warranty gives you specific legal rights and you may also have other rights which vary from state to state. If a problem with this product develops during or after the warranty period, you may contact your dealer or service center. If the problem is not handled to your satisfaction, then write to the Consumer Affairs Department at the listed address on the back cover.

WARRANTY

Panasonic Canada Inc.
5770 Ambler Drive, Mississauga, Ontario L4W 2T3

Panasonic Platinum Series Vacuum Cleaner Limited Warranty

EXCHANGE PROGRAM

Panasonic Canada Inc. warrants this product to be free from defects in material and workmanship and agrees to replace the product for a period as stated below from the date of original purchase.

Platinum Series Vacuum Cleaner - Two (2) years

LIMITATIONS AND EXCLUSIONS

This warranty does not apply to products purchased outside Canada or to any product which has been improperly installed, subjected to usage for which the product was not designed, misused or abused, damaged during shipping, or which has been altered or repaired in any way that affects the reliability or detracts from the performance, nor does it cover any product which is used commercially. Parts such as disposable dust bags, filters, belts, light bulbs and agitator brushes are not covered by this warranty. Rechargeable batteries are warranted for ninety (90) days from date of original purchase. This warranty is extended to the original end user purchaser only. A purchase receipt or other proof of date of original purchase is required before warranty service is performed.

THIS EXPRESS, LIMITED WARRANTY IS IN LIEU OF ALL OTHER WARRANTIES, EXPRESS OR IMPLIED, INCLUDING ANY IMPLIED WARRANTIES OF MERCHANTABILITY AND FITNESS FOR A PARTICULAR PURPOSE.

IN NO EVENT WILL PANASONIC CANADA INC. BE LIABLE FOR ANY SPECIAL, INDIRECT OR CONSEQUENTIAL DAMAGES.

In certain instances, some jurisdictions do not allow the exclusion or limitation of incidental or consequential damages, or the exclusion of implied warranties, so the above limitations and exclusions may not be applicable.

CONTACT INFORMATION

For product information and operation assistance, please contact:

Our Customer Care Centre: Telephone #: (905) 624-5505
1-800 #: 1-800-561-5505
Fax #: (905) 238-2360
Email link: "customer support" on www.panasonic.ca

For defective product exchange within the warranty period, please contact the original dealer or our Customer Care Centre.