

Panasonic®

VACUUM CLEANER

Aspirateur

Aspiradora

MC-UG693

Operating Instructions

Manuel d'utilisation

Instrucciones de operación

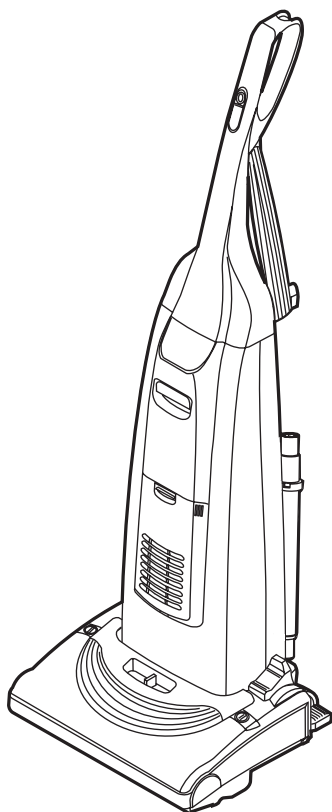

**Before operating your vacuum cleaner,
please read these instructions completely.**

Avant d'utiliser l'appareil, il est recommandé
de lire attentivement ce manuel.

*Antes de usar su aspiradora, lea
completamente estas instrucciones por favor.*

CONSUMER INFORMATION

Please read **IMPORTANT SAFETY INSTRUCTIONS** on page 5 before use. Read and understand all instructions.

TO OUR VALUED CUSTOMER

We are very pleased to welcome you to the Panasonic family of products. Thank you for purchasing this product. Our intent is that you become one of our many satisfied customers.

Proper assembly and safe use of your vacuum cleaner are your responsibilities. Your vacuum cleaner is intended only for household use. The vacuum cleaner should be stored in a dry, indoor area. Read the Operating Instructions carefully for important use and safety information.

Special care is required when vacuuming certain types of carpet or floor covering. Always check the carpet or floor covering manufacturer's recommended cleaning instructions before vacuuming.

PLEASE PAY CLOSE ATTENTION TO ALL WARNING AND CAUTION STATEMENTS.

WARNING

WARNING statements are designed to alert you to the possibility of personal injury, loss of human life, and/or damage to the vacuum cleaner and/or personal property if the instructions given are not followed.

CAUTION

CAUTION statements are designed to alert you to the possibility of damage to the vacuum cleaner and/or personal property if the instructions given are not followed.

WARNING

TO AVOID ELECTRICAL SHOCK

Never vacuum damp or wet surfaces or liquids.
DO NOT store vacuum cleaner outdoors.
Replace worn or frayed power cord immediately.
Unplug from outlet when not in use and before servicing.

TO AVOID ACCIDENTS

Except for hand-held vacuum cleaners, keep vacuum cleaner on floor - not chairs, tables, steps, stairs, etc.
Store vacuum cleaner promptly after each use to prevent accidents such as tripping over power cord or vacuum cleaner. Use vacuum cleaner and accessories only in a manner intended by the manufacturer. The use of an extension cord is not recommended.

IMPORTANT SAFETY INSTRUCTIONS

When using your vacuum cleaner, basic precautions should always be followed, including the following:

Read all instructions in this manual before assembling or using your vacuum cleaner.

WARNING To reduce the risk of fire, electrical shock, injury:

1. **Use** your vacuum cleaner only as described in this manual. Use only with Panasonic recommended attachments.
2. **Disconnect** electrical supply before servicing or cleaning out the brush area.
3. **Do not** leave vacuum cleaner when plugged in. Unplug from outlet when not in use and before servicing.
4. **To reduce** the risk of electrical shock - Do not use outdoors or on wet surfaces.
5. **Do not** allow to be used as a toy. Close attention is necessary when used by or near children.
6. **Do not** use with a damaged cord or plug. If vacuum cleaner is not working as it should, has been dropped, damaged, left outdoors, or dropped in water, return it to a Panasonic Service Center.
7. **Do not** pull or carry by cord, use cord as a handle, close a door on cord, or pull cord around sharp edges or corners. Do not run vacuum cleaner over cord. Keep cord away from heated surfaces.
8. **Do not** unplug by pulling on cord. To unplug, grasp the plug, not the cord.
9. **Do not** handle plug or vacuum cleaner with wet hands.
10. **Do not** put any objects into openings.
11. **Do not** use with any opening blocked; keep free of dust, lint, hair, and anything that may reduce air flow.
12. **Keep** hair, loose clothing, fingers, and all parts of body away from openings and moving parts.
13. **Turn off** all controls before unplugging.
14. **Use** extra care when cleaning on stairs. Do not put on chairs, tables, etc. Keep on floor.
15. **Do not** use vacuum cleaner to pick up flammable or combustible liquids (gasoline, cleaning fluid, perfumes, etc.), or use in areas where they may be present. The fumes from these substances can create a fire hazard or explosion.
16. **Do not** pick up anything that is burning or smoking, such as cigarettes, matches, or hot ashes.
17. **Do not** use vacuum cleaner without dust bag and/or filters in place.
18. **Unplug** before connecting Air Turbine (if applicable).
19. **You are** responsible for making sure that your vacuum cleaner is not used by anyone unable to operate it properly.

SAVE THESE INSTRUCTIONS

THIS VACUUM CLEANER IS INTENDED FOR HOUSEHOLD USE ONLY

NOTE: Before you plug in your Panasonic vacuum cleaner, make sure that the voltage indicated on the rating plate located at the back of the vacuum cleaner is the same as your local electrical supply.

TABLE OF CONTENTS

CONSUMER INFORMATION	2
IMPORTANT SAFETY INSTRUCTIONS	5
PARTS IDENTIFICATION	10
FEATURE CHART	11
ASSEMBLY	12
Attaching Hose	12
Attaching Handle.....	14
Power Cord	16
TO OPERATE VACUUM CLEANER	16
Power Cord	18
ON-OFF Switch	20
Handle Adjustments	20
Using Tools	22-26
Tool Use Chart	26
FEATURES	28
Height Adjust Selection	28
Carpet-Bare Floor Selector	30
Edge Cleaning	30
Thermal Protector	32
Motor Protector	34
VACUUMING TIPS	36
ROUTINE CARE OF VACUUM CLEANER	38
Vacuum Cleaner Storage	38
Cleaning Exterior and Tools.....	40
Changing Dust Bag	42-44
Replacing Motor Safety Filter	46
Replacing HEPA Exhaust Filter	48
Removing Belt	50
Replacing Belt	52-56
Cleaning Agitator.....	56
Replacing Headlight Bulb.....	58
Replacing Agitator.....	60
Removing Clogs.....	62-64
BEFORE REQUESTING SERVICE	66
WARRANTY	69,70
WHAT TO DO WHEN SERVICE IS NEEDED	76

PARTS IDENTIFICATION

Nomenclature

Identificación de piezas

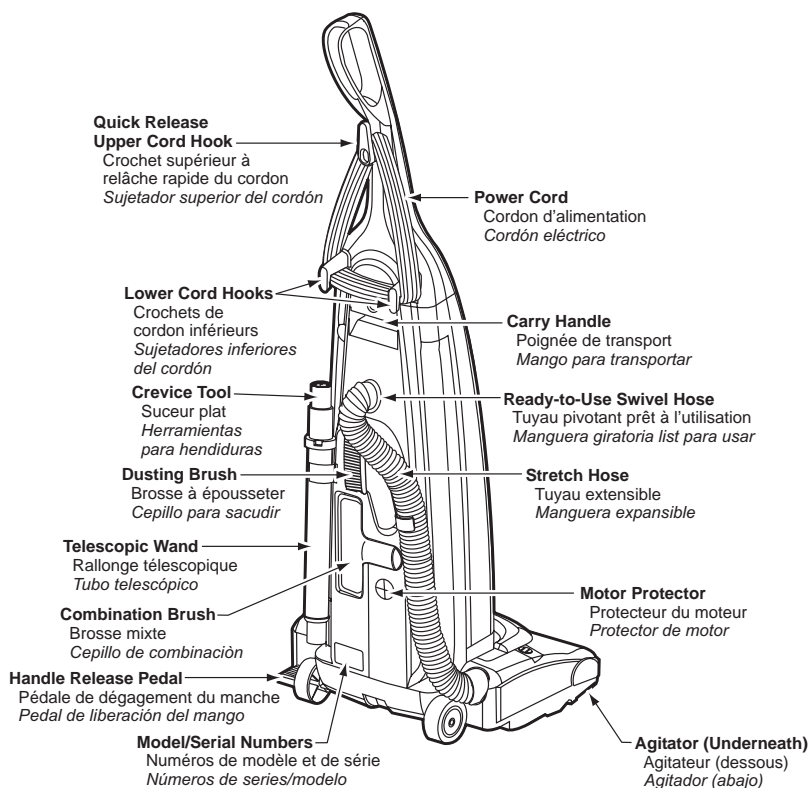

FEATURE CHART

Power	Thermal Protector	Cord Length	Tools
120V AC(60Hz)	Yes	10.7 m (35 Ft.)	Yes



Tableau des caractéristiques

Alimentation	Protecteur thermique	Longueur du cordon	Accessoires
120 V c.a. (60 Hz)	Oui	10,7 m (35 pi)	Oui

Diagrama de características

Voltaje	Protector termal	Extensión de cordón	Herramientas
120 V c.a. (60 Hz)	Si	10,7 m (35 pi)	Si

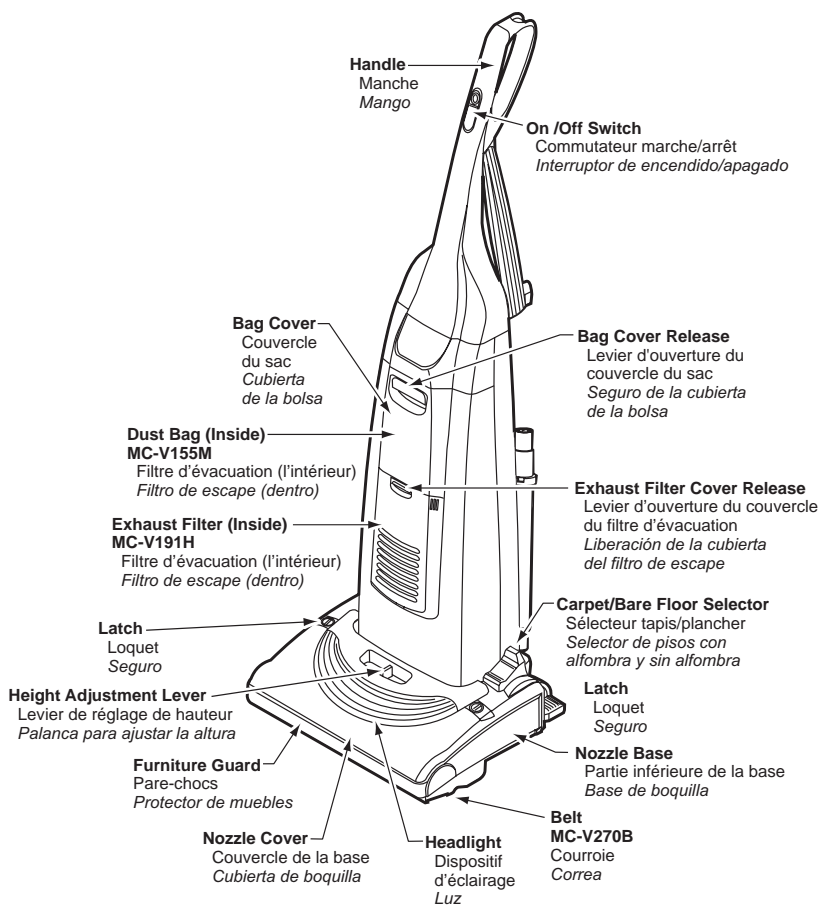
ASSEMBLY



WARNING

Electrical Shock Hazard

Do not plug into the electrical supply until the assembly is complete. Failure to do so could result in electrical shock or injury.

Attaching Hose

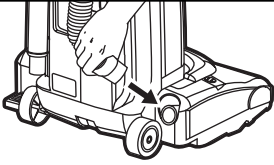

- Attach stretch hose end to nozzle as shown.

Attaching Handle

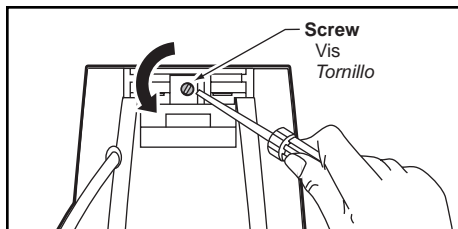

➤ Remove the screw located just below the top edge of the back of the vacuum cleaner.

➤ Position the handle as shown in the illustration.

➤ Slide the handle into the opening at the top of the vacuum cleaner.

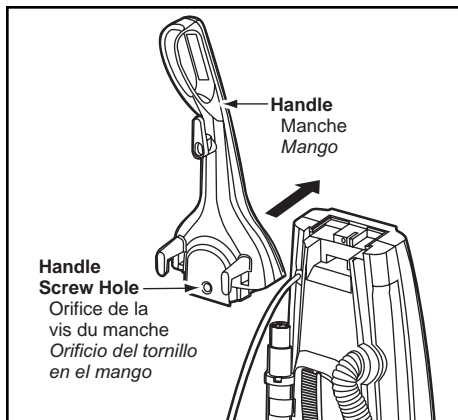

➤ Insert the screw so it passes through the handle into the vacuum cleaner.

➤ Begin to tighten the screw with your fingers. It may be necessary to adjust the handle slightly.

➤ Using a screwdriver, tighten the screw.

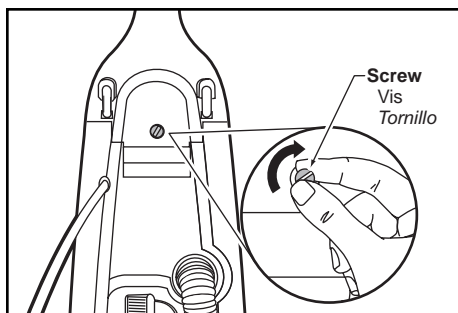

CAUTION

Do not overtighten.

Overtightening could strip the screw holes.

Do not operate the vacuum cleaner without the screw in place.

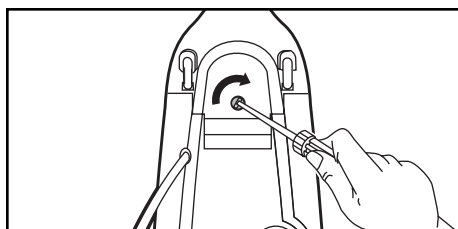

Attaching Power Cord

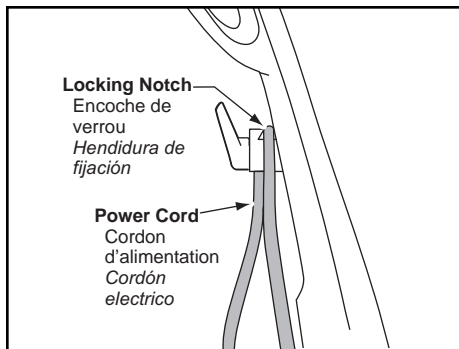

- Make sure the quick release upper cord hook is in the upright position.
- Remove the wire tie from the power cord.
- Lock the cord into place by forcing it into the locking notch on the body of the quick release upper cord hook as shown.
- This helps keep the power cord out from under the vacuum cleaner agitator.
- Wrap the power cord around the upper and lower cord hooks and lock the power cord plug onto the power cord.

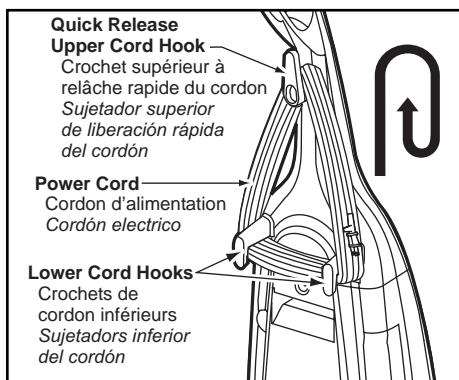

TO OPERATE VACUUM CLEANER

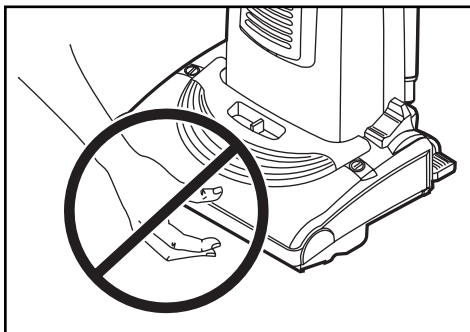

CAUTION

Moving parts! To reduce the risk of personal injury, **DO NOT** touch the brush when vacuum cleaner is on. Contacting the brush while it is rotating can cut, bruise or cause other injuries. Always unplug from electrical outlet before servicing.

Use caution when operating near children.

Power Cord

NOTE: To reduce the risk of electrical shock, this vacuum cleaner has a polarized plug, one blade is wider than the other. This plug will fit in a polarized outlet only one way. If the plug does not fit fully in the outlet, reverse the plug. If it still does not fit, contact a qualified electrician to install the proper outlet. **DO NOT CHANGE THE PLUG IN ANY WAY.** Only use outlets near the floor.

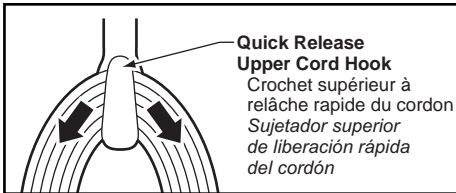

- Turn the quick release upper cord hook to either side and down to release the power cord.
- Detach the power cord plug from the power cord and pull the cord off the quick release upper cord hook.
- Be sure the power cord is still locked into the locking notch of the upper cord hook.
- Plug the polarized power cord into a 120 Volt outlet located near the floor.
- To replace cord, turn upper hook counter-clockwise pointing up, then wrap cord.



WARNING

Personal Injury and Product Damage
Hazard

- DO NOT place hands or feet under the vacuum cleaner at any time.
 - DO NOT use outlets above counters.
- Damage from cord to items in surrounding area could occur.

ON-OFF Switch

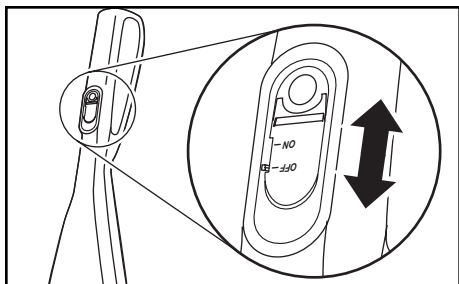

- Ensure ON-OFF switch is OFF.
- Plug the power cord into 120V outlet.
- ON position turns vacuum cleaner on.
- OFF position turns vacuum cleaner off.

Handle Adjustments

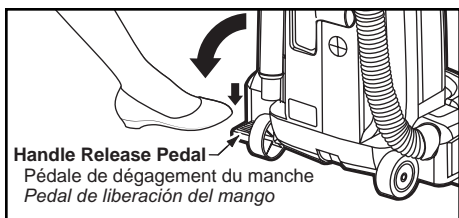

- Release the handle by pressing down on the handle release pedal with your foot and pulling back and down on the handle with your hand.

Using Tools

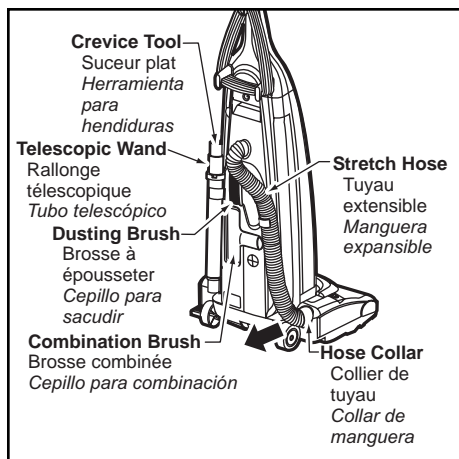

- Place the carpet/bare floor selector in the bare floor setting by rotating the selector back and down to the bare floor setting. See **CARPET/BARE FLOOR SELECTOR** section.

NOTE: When returning the bare floor selector to the carpet setting, use caution as the selector can move quickly to that setting due to tension created by the belt.

- Identify each of the attachments shown.

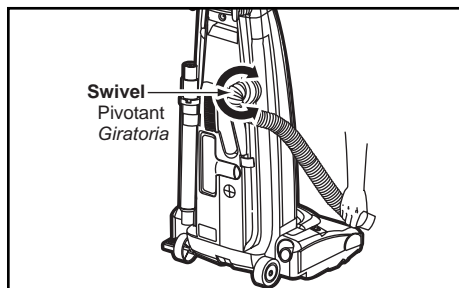

- Remove the lower end of the stretch hose from the vacuum cleaner by grasping the hose collar, twisting and pulling straight out.

- The attachments can now be added to the hose.

- The attached hose swivels to make cleaning easier in every direction.

- Remove the hose from the hose clip by pulling straight out.

NOTE: The motor protector may open when using attachments or when cleaning new carpet, due to reduced airflow by the attachments themselves or by new carpet fuzz filling the dust bin quickly. See the **TROUBLESHOOTING** section.



CAUTION

Do not allow vacuum cleaner to remain in one spot for any length of time when the agitator is turning. Damage to carpet may occur.

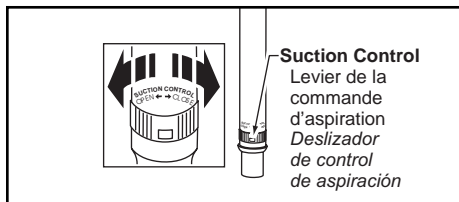
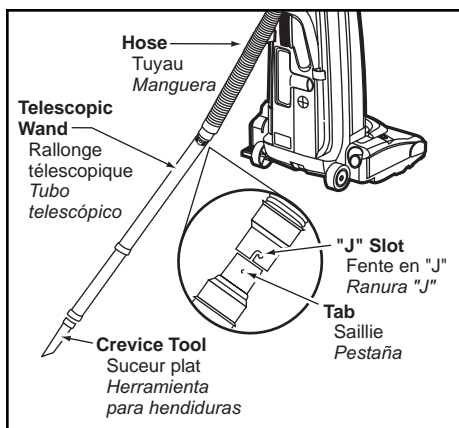
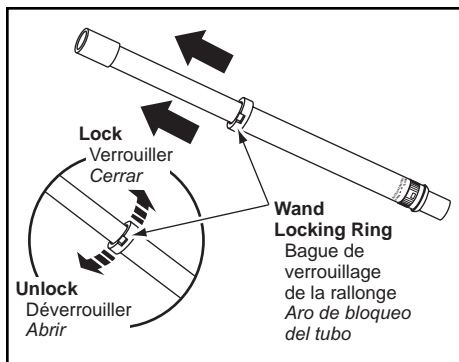
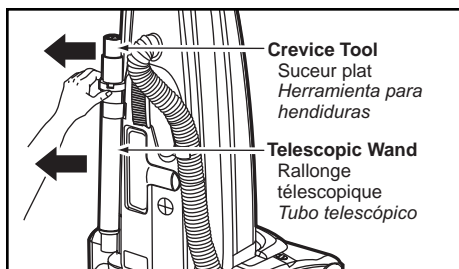

TELESCOPING WAND:

- Remove the telescopic wand from its storage position.
- Remove the crevice tool from its storage position in the wand.
- Turn the locking ring to the UNLOCK position.
- Extend the wand to its full length.
- Turn the locking ring to the LOCK position.
- Attach the extension wand onto the open end of the hose.
- Align the tabs on the extension wand with the "J" slots in the hose (as illustrated above right).
- Push the wand into the hose and twist to the right to lock.

SUCTION CONTROL SLIDE Telescopic Wand

- When using attachments for cleaning draperies, small rugs with low pile and other delicate items, twist the suction control slide to the open position.
- This will reduce suction for ease of cleaning.
- The slide is located on the telescopic wand, close to the hose.

Note: Return suction control slide to the closed position for normal cleaning.

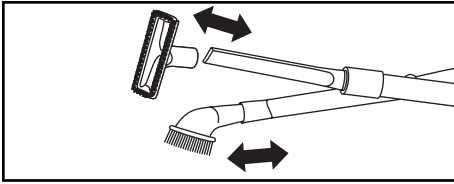

- To achieve maximum reach with the attachments, add the crevice tool to the end of the wand by inserting and twisting slightly.
- The dusting brush or the combination brush may be attached directly to the wand or placed on the end of the crevice tool.

CAUTION

When using attachments, be careful not to overextend the stretch hose when reaching. Trying to reach beyond the hose stretch capability could cause the vacuum cleaner to tip over. Make sure the carpet/bare floor selector is in the bare floor position. Damage to the floor surface may occur if the carpet setting is used.

Tool Use Chart

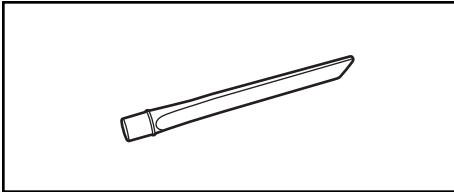

- The Crevice Tool may be used on the following items:
 - Furniture
 - Cushions
 - Drapes
 - Stairs
 - Walls

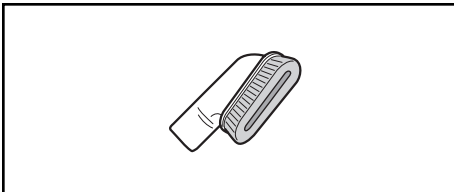

- The Dusting Brush may be used on the following items:
 - Furniture
 - Drapes
 - Stairs
 - Walls



- The Combination Brush may be used on the following items:
 - Furniture
 - Drapes
 - Stairs
 - Walls

FEATURES

Height Adjust Selection

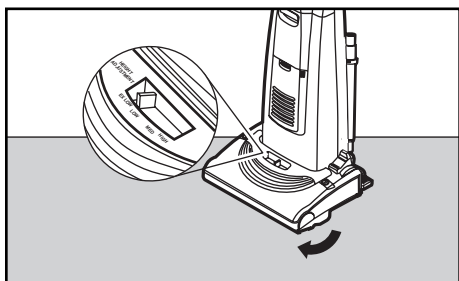

To select a pile height setting:

- Turn off vacuum cleaner.
- Select a pile height setting by tilting the vacuum cleaner back until front wheels are lifted slightly off the floor as illustrated.
- Slide the adjustment lever to the correct setting.

SUGGESTED PILE HEIGHT SETTINGS

You may need to raise the height to make some jobs easier, such as scatter rugs and longer pile carpets.

Suggested settings are:

HIGH: shag carpet, long pile, plush, scatter rugs.

MED: medium to long pile.

LOW: short to medium pile.

EX LOW: very low pile.



WARNING

Personal Injury Hazard

DO NOT place hands or feet underneath the vacuum cleaner when changing from the bare floor to the carpet pile height setting. The agitator begins to revolve rapidly when the vacuum cleaner is turned on and is in the carpet setting.

Carpet/Bare Floor Selector

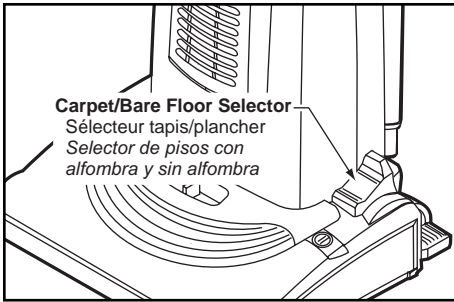

➤ Selector should be placed in **BARE FLOOR (TOOLS)** position when using vacuum cleaner on bare floors and when using tools.

➤ The agitator does not rotate in the **BARE FLOOR (TOOLS)** position.

➤ Selector should be placed in **CARPET** position when using vacuum cleaner on carpeted floors.

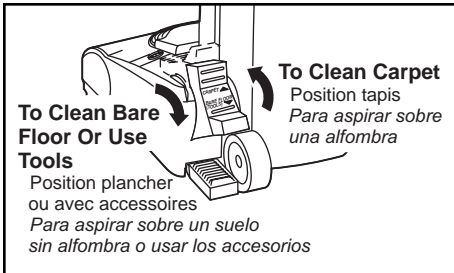

➤ For longer belt life, turn vacuum cleaner off before moving selector.

➤ Otherwise, take care when selecting either position to ensure selector is pushed as **fully and quickly** as possible to desired position.

➤ Failure to do so can cause belt to rub on selector shaft and result in belt becoming hot and creating a burning rubber smell.

Edge Cleaning

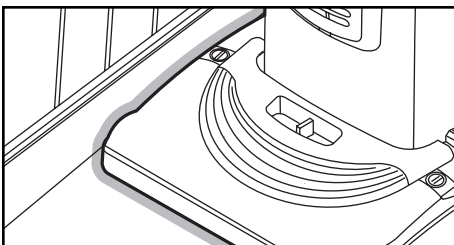

➤ Edge cleaning feature enables improved cleaning of carpets near walls and furniture.

Thermal Protector

- If a clog prevents the normal flow of air to the motor, the thermal protector turns the motor off automatically to allow the motor to cool in order to prevent possible damage to the vacuum cleaner.
- During this time the headlight remains on.
- To correct problem, turn off and unplug vacuum cleaner, remove clogs, and/or clean/replace filters.
- Replace full bag if necessary.
- Wait approximately thirty (30) minutes, plug vacuum cleaner in, turn on to see if thermal protector has reset. Thermal protector will not reset if vacuum cleaner is not turned off even if vacuum cleaner cools down.

Motor Protector

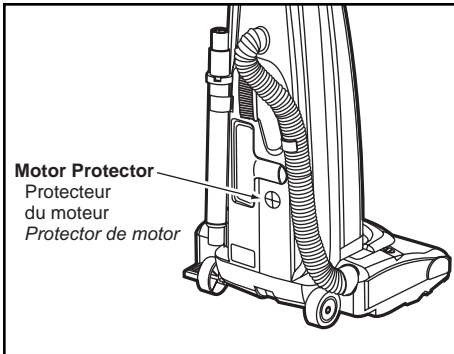

- The motor protector is located behind the wand holder on the back of the vacuum cleaner.
- Automatically opens to provide cooling air to the motor when a clog occurs or when dust bag is full.
- Motor protector may open when using tools.
- Check operation by placing hand over end of hose.
- If the motor protector opens, the vacuum cleaner will make a different sound.
- Do not block motor protector.

VACUUMING TIPS

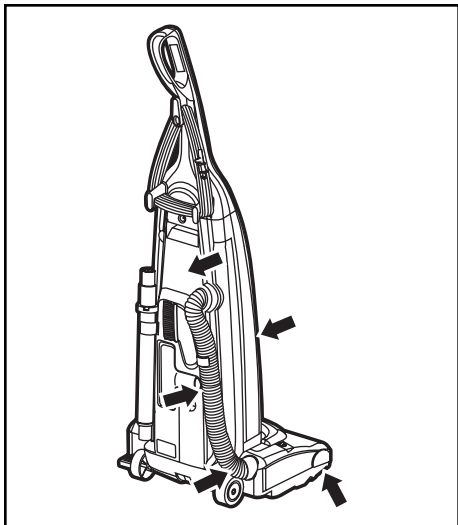

Carpet edges:

- Guide either side or the front of the nozzle along a baseboard.
- The full length brushes help remove dirt at carpet edges.

Stairs:

- Put handle in full upright position.
- Place the carpet/bare floor selector in the bare floor position.
- Use the crevice tool or fabric brush.

- Set the ON/OFF switch to ON.

For best cleaning results:

- Keep the airflow passage clear.
- Occasionally, check each of the areas indicated for clogs.
- Unplug the vacuum cleaner from the outlet before checking.



WARNING

Personal Injury Hazard

Use care if vacuum cleaner is placed on stairs. If it falls, personal injury or property damage could result.

ROUTINE CARE OF VACUUM CLEANER

Performing the following tasks will keep your new Panasonic vacuum cleaner operating at peak performance levels and will ensure these high levels for years to come. Check the **BEFORE REQUESTING SERVICE** section in this manual for recommendations on performing some of these tasks to help solve various problems that may occur.

Always follow all safety precautions when cleaning and servicing the vacuum cleaner.

WARNING

Electrical Shock And Personal Injury Hazard

Disconnect electrical supply before performing maintenance to the vacuum cleaner. Failure to do so could result in electrical shock or personal injury from vacuum cleaner suddenly starting.

Vacuum Cleaner Storage

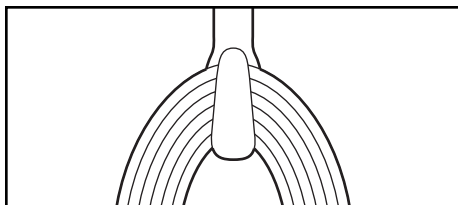

- Gather the cord and wrap it loosely around the upper and lower cord hooks.
- Store the vacuum cleaner in a dry, indoor area, on the floor with the handle locked in the upright position.

WARNING

Electrical Shock And Personal Injury Hazard

Wrapping the cord too tightly puts stress on the cord and can cause cord damage. A damaged cord is an electrical shock hazard and could cause personal injury or damage.

Cleaning Exterior and Tools



CAUTION

Do not use attachments if they are wet. Attachments used in dirty areas, such as under a refrigerator, should not be used on other surfaces until they are washed. They could leave marks.

- **Unplug cord from wall outlet.**

- **DO NOT drip water on vacuum cleaner.**

- **Clean exterior using a clean, soft cloth that has been dipped in a solution of mild liquid detergent and water, then wrung dry.**

- **Wipe dry after cleaning.**

- **To reduce static electricity and dust build-up, wipe outer surface of vacuum cleaner and attachments.**

- **Wash attachments in warm soapy water, rinse and air dry.**

- **Do not clean in dishwasher.**

Changing Dust Bag

Always operate vacuum cleaner with genuine Panasonic type dust bags installed. Panasonic dust bags may be purchased through any authorized Panasonic dealer or ordered from service company.

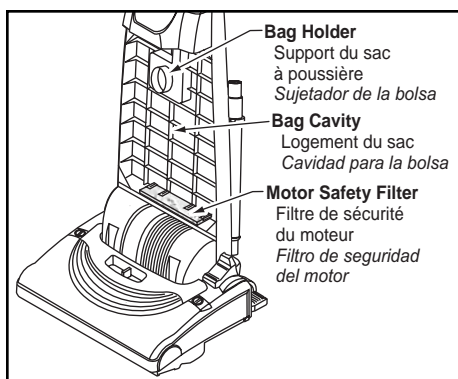
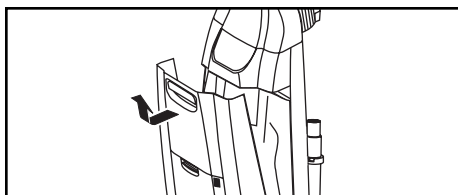
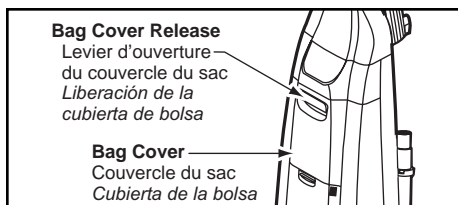

TO REMOVE DUST BAG

- Pull out on the bag cover release located near the top of the bag cover.
- Pull the bag cover forward and lift up. Remove and lay aside.
- Grasp the dust bag collar and pull gently, carefully removing the dust bag.
- Throw away the used dust bag.
- Do not reuse.
- Check the bag holder and the motor safety filter.
- If either is blocked, check TROUBLESHOOTING.

CAUTION

NEVER REUSE A DUST BAG. Very fine materials, such as carpet freshener, face powder, fine dust, plaster, soot, etc. can clog the bag and cause it to burst before it is full. Change bag more often when vacuuming these materials.

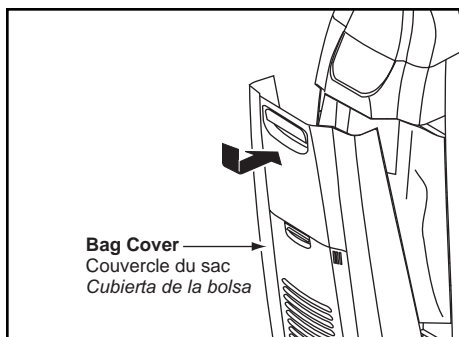
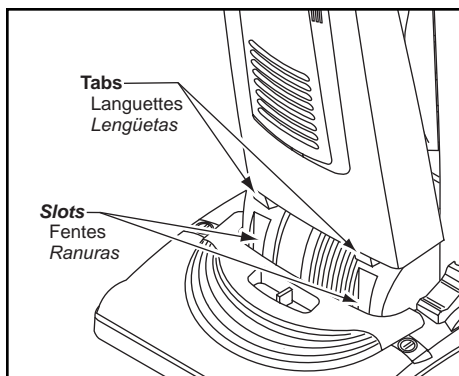
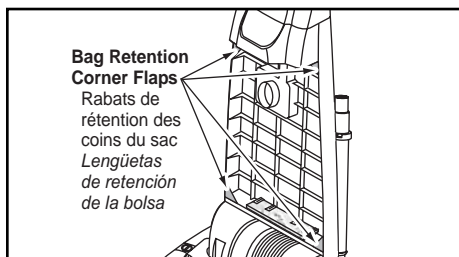
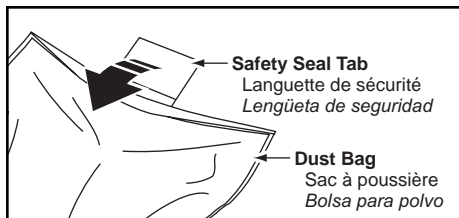

TO REPLACE DUST BAG

- **Unfold the new dust bag.**
- **Fold the safety seal tab on the new dust bag away from the opening that fits on the bag holder.**

Note: See PARTS IDENTIFICATION for dust bag number.

- **Insert the dust bag onto the bag holder completely by holding the bag collar.**
- **Place the dust bag collar into position.**
- **Tuck the bag behind each of the four bag retention corner flaps shown here.**
- **Be sure the bottom and sides of the dust bag are completely within bag cavity prior to replacing the bag cover.**
- **Position the bag cover so its positioning tabs fit into the body positioning tab slots.**
- **Close the bag cover.**
- **You will hear a distinct snap when cover is securely closed.**
- **Check to see that the dust bag is fully enclosed in the bag cover.**

Replacing Motor Safety Filter

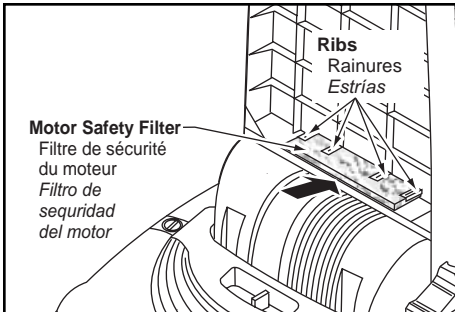
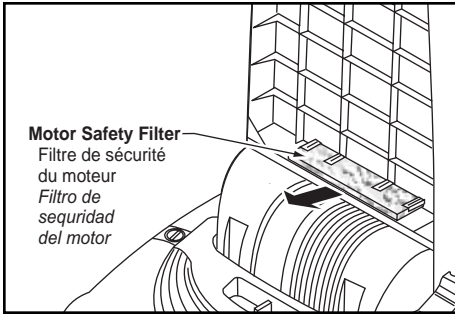
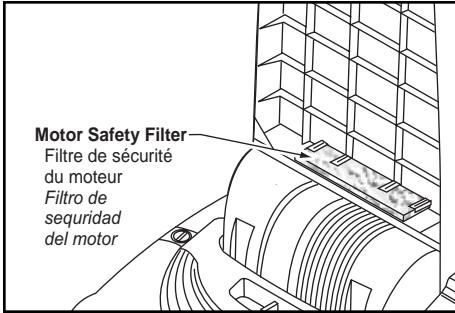

The filter must be replaced when dirty. It should be replaced regularly depending on use conditions. The filter **CANNOT** be washed as it will lose its dust trapping ability.

WARNING

Electrical Shock Hazard

Do not operate the vacuum cleaner without the motor safety filter. Be sure the filter is dry and properly installed to prevent motor failure and/or electrical shock.

- Check motor safety filter frequently and change when dirty.
- Remove the dust bag as outlined in the **DUST BAG CHANGING** section.

NOTE: See **PARTS IDENTIFICATION** for motor safety filter number.

- If the filter, located in the bottom of the bag cavity, is dirty, remove it by pulling forward out from under the ribs.
- Replace the filter, smooth (white) side up, by sliding it back into place under the ribs in the bag cavity.
- Replace the bag as outlined in the **DUST BAG CHANGING** section.

Replacing HEPA Exhaust Filter

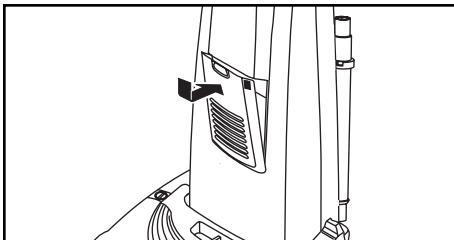
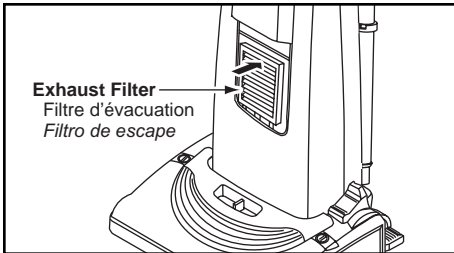
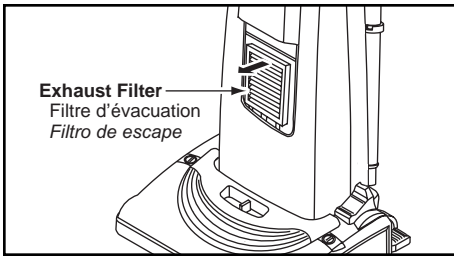
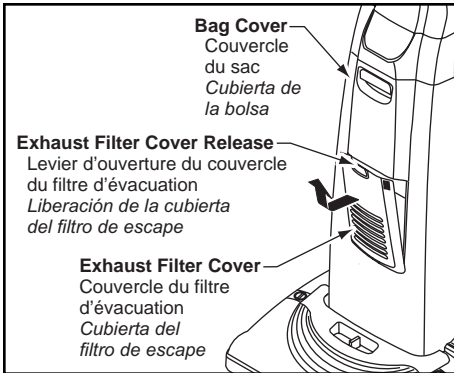

The filter must be replaced when dirty. It should be replaced regularly depending on use conditions. The filter **CANNOT** be washed as it will lose its dust trapping ability.

WARNING

Do not operate without exhaust filter.

- Slide the exhaust filter cover release down.
- Pull out on exhaust filter cover to remove from bag cover.
- Remove the exhaust filter cartridge from the bag cover.

Note: See PARTS IDENTIFICATION for the exhaust filter number.

- Replace the exhaust filter cartridge, carefully positioning it so that it fits into the bag cover.
- The grey edge of the filter should be facing away from the operator. Push only on filter cartridge frame, not on filter itself.
- Replace the exhaust filter cover and secure the latch by pushing it upward.

Removing Belt

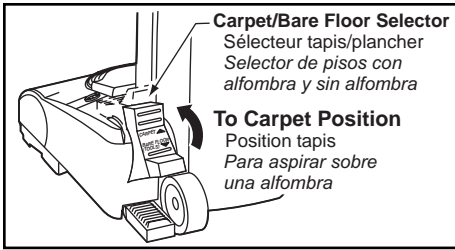

- Disconnect power cord from electrical outlet.
- Place the carpet/bare floor selector in the carpet position.
- Slide latches outward and remove nozzle cover.

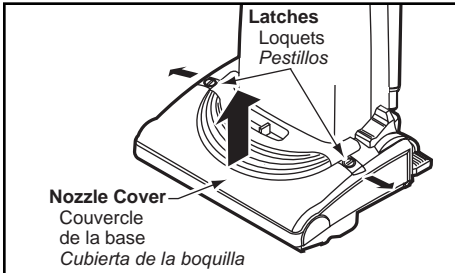

- Unfasten the furniture guard retainers from the posts on both sides of the agitator cover.
- Depress tabs on rear of agitator cover and rotate forward to release from the nozzle body.

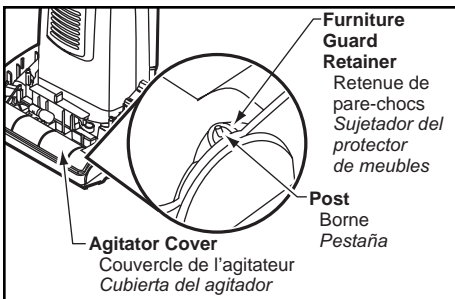

- The light bulb socket assembly does not have to be removed. Lay the agitator cover over to the side out of the way.
- Position hands on the agitator. If the belt is still attached to the agitator, there will be tension on the agitator.

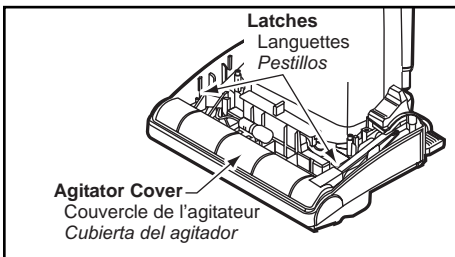

- Carefully lift the right end of the agitator and then the left end.

Note: It may be necessary to pull the edge of the furniture guard out of the way to allow the ends of the agitator to be removed easily.

- Remove the belt from the motor drive shaft.

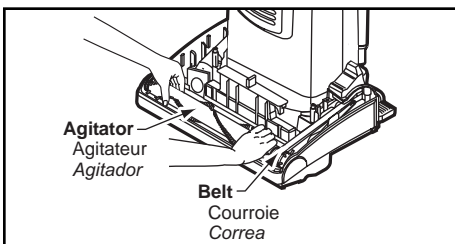

WARNING

Personal Injury Hazard

Be careful when removing the agitator as the belt tension is high. Failure to do so could result in personal injury from the agitator releasing quickly and snapping away.

Replacing Belt

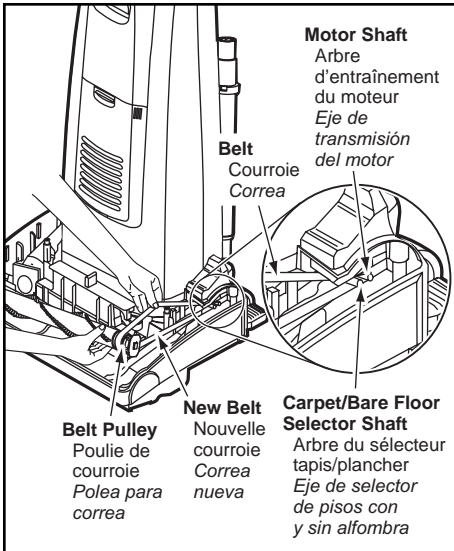

- Make sure that the carpet/bare floor selector is in the carpet position.
- Loop the new belt on the motor shaft.

BELT ROUTING

Correct Routing of Belt (Selector in Carpet Position)

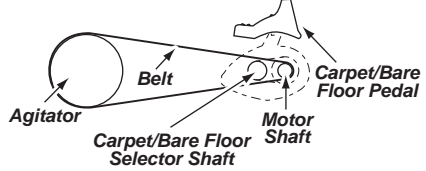

Incorrect Routing of Belt (Belt on Selector Shaft)

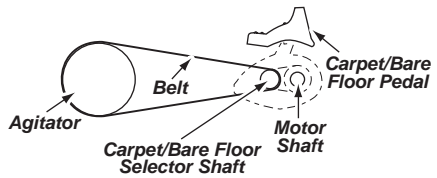

Incorrect Routing of Belt (Selector in Bare Floor Position)

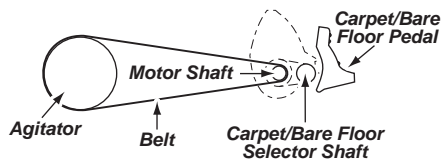

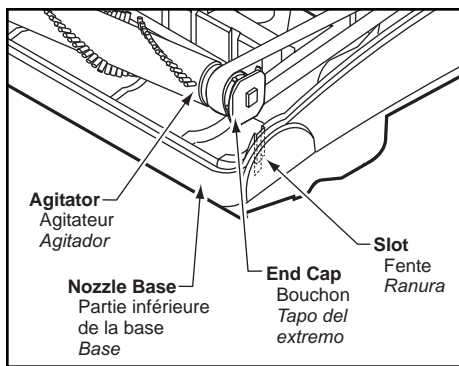

Note: See PARTS IDENTIFICATION for belt number.

- Loop the other end of the belt on the belt pulley on the agitator.
- Insert the agitator by placing the rounded portion of the end cap down into the slot in the nozzle base.

Note: It may be necessary to hold the furniture guard out of the way in order to allow proper insertion of the agitator into the nozzle base.

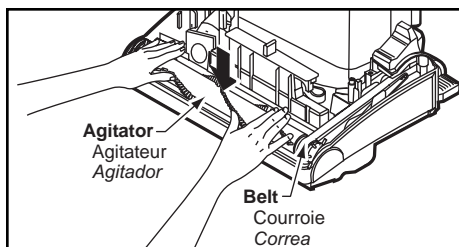

Note: Care must be taken due to the belt tension during reassembly.

- Press firmly, checking to see that each end is completely inserted.

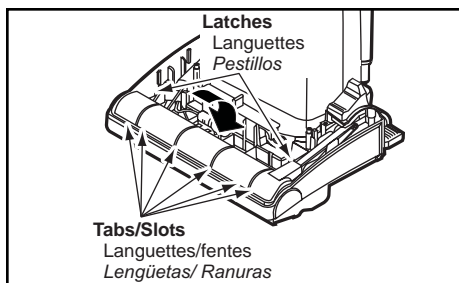

- Check to see that the belt is centered on the belt pulley. Turn the agitator with your fingers to see that it turns freely.
- To re-attach the agitator cover, insert the six (6) tabs into the six slots along the front edge of the nozzle base.

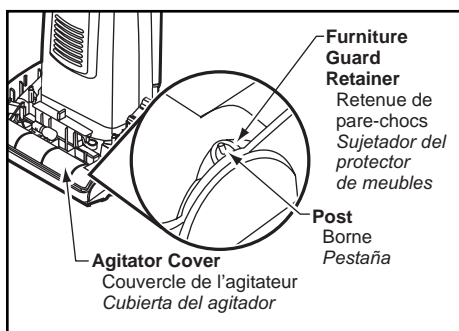

- Lower the agitator cover to its original position.
- After positioning the agitator cover, push forward on the two (2) locking tabs in order to ensure that they are securely in place.
- Re-fasten the furniture guard retainers to the posts on both sides of the agitator cover.

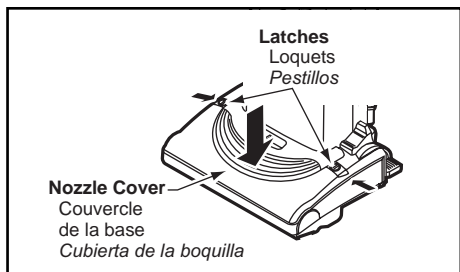
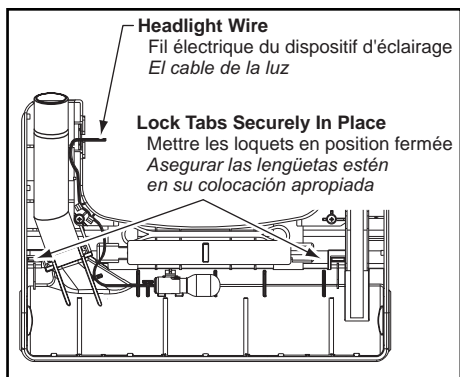

Note: If the agitator cover is not installed correctly, you may experience a loss of performance and possible agitator vibration, etc.

- **Make sure the headlight wires are tucked securely in place.**
- **Replace the nozzle cover and secure the latches.**

Cleaning Agitator

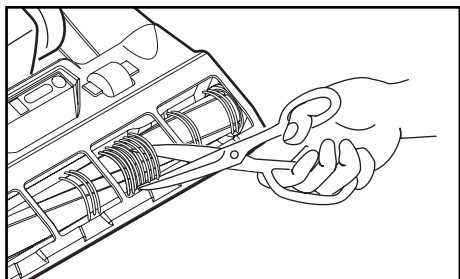

- **Clean agitator after every five uses and every time the belt is replaced.**
- **Cut off any carpet pile and lint entangled around agitator with a pair of scissors.**
- **Remove agitator.**
- **Remove any string or debris located on the end caps, washers or agitator shaft.**
- **Reinstall agitator, agitator cover, and nozzle cover**

Replacing Headlight Bulb

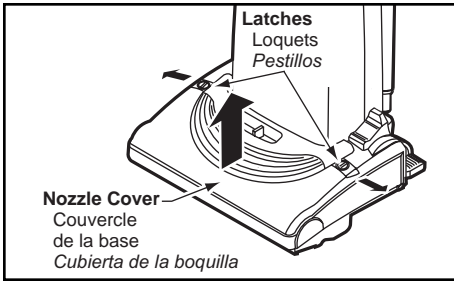

- Disconnect power cord from electrical outlet.
- Slide latches outward and remove nozzle cover
- Remove the light bulb by pushing the bulb in while turning counter-clockwise to release from the slot.

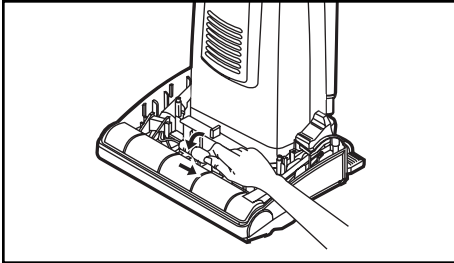

- Only use a bulb rated 130 V AC-15 Watts or less.
- To replace the light bulb carefully insert and turn clockwise to securely fit into slot.

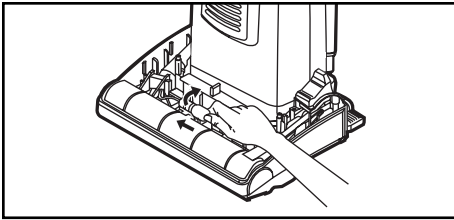

- Replace the nozzle cover and secure the latches.

NOTE: DO NOT plug in or turn on until the vacuum cleaner is completely reassembled.

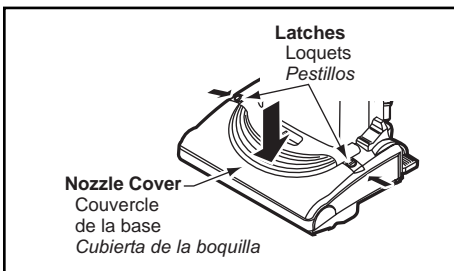

Replacing Agitator

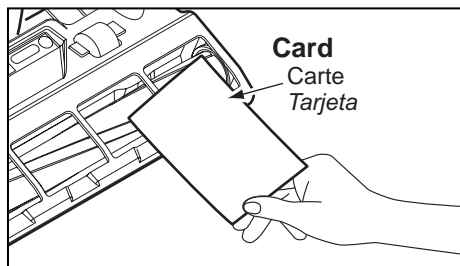

- When the bristles on the agitator are worn so that they do not touch a card held across the lower plate, the brushes should be replaced.
- Remove the nozzle cover, agitator cover and agitator. See **REMOVING BELT**.
- Replace the agitator with a new one.
- Reassemble the belt, agitator, agitator cover and nozzle cover. See **REPLACING BELT** section.

Removing Clogs

WARNING

Electrical Shock Or Personal Injury Hazard

Disconnect electrical supply before servicing or cleaning the vacuum cleaner. Failure to do so could result in electrical shock or personal injury from vacuum cleaner suddenly starting.

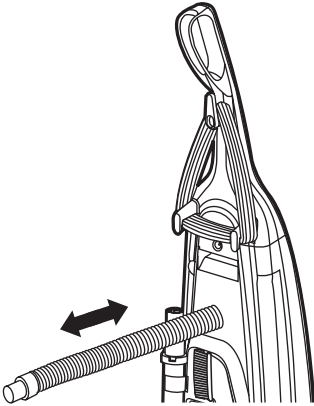

Stretch Hose In and Out
Étirer et relâcher le tuyau
Extienda y afloje la manguera

Always follow all safety precautions when cleaning and servicing the vacuum cleaner.

- If the vacuum cleaner does not seem to have adequate suction, first check if the dust bag is full or if a filter is clogged. See **DUST BAG CHANGING** and **FILTER CHANGING**.

- If the bag and filter areas are free of clogs, check the hose area.

- Remove the lower end of the stretch hose from the vacuum cleaner by grasping the hose collar, twisting, and pulling straight out.

- Plug in the vacuum cleaner and turn it on.

- Stretch the hose to maximum length and then allow the hose to return to its storage length.

- Turn off and unplug the vacuum cleaner.

- Visually inspect the hose and the base area into which the hose is inserted.

- Remove any visible clog.

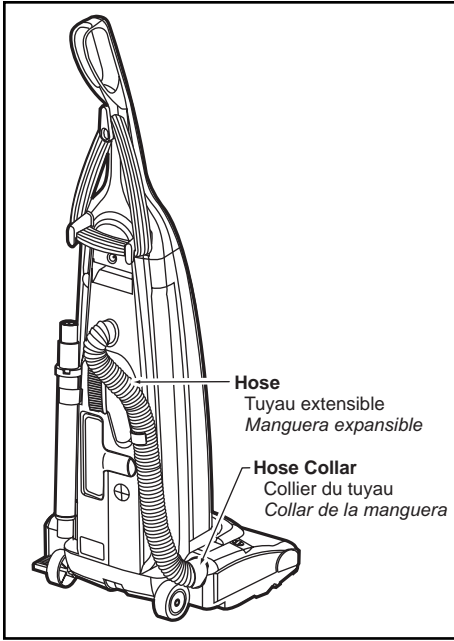

! WARNING

Personal Injury Hazard

DO NOT place hands or feet underneath the vacuum cleaner at any time. The agitator will be revolving rapidly when the vacuum cleaner is turned on and is in the carpet setting.

- **Re-insert the hose into the opening on the lower body from which it was removed.**
- **Press firmly to assure connection.**
- **If the bag and filter areas and the hose areas are free of clogs, check the nozzle area.**
- **To check this area, see the section on BELT CHANGING AND AGITATOR CLEANING.**
- **Return the vacuum cleaner to the upright position before plugging into an electrical outlet.**

BEFORE REQUESTING SERVICE



WARNING

Electrical Shock or Personal Injury Hazard

Disconnect the electrical supply before servicing or cleaning the vacuum cleaner. Failure to do so could result in electrical shock or personal injury from vacuum cleaner suddenly starting.

Review this chart to find do-it-yourself solutions for minor performance problems. Any service needed, other than those described in these Operating Instructions, should be performed by an authorized service representative.

PROBLEM	POSSIBLE CAUSE	POSSIBLE SOLUTION
Vacuum Cleaner won't run.	<ol style="list-style-type: none"> 1. Unplugged at wall outlet. 2. Tripped circuit breaker/blown fuse. 3. On/off switch not turned on. 	<ol style="list-style-type: none"> 1. Plug in firmly, push on/off switch to on. 2. Reset circuit breaker or replace fuse at household service panel. 3. Push on/off switch to on.
Poor job of dirt pick-up.	<ol style="list-style-type: none"> 1. Full or clogged dust bag. 2. Wrong pile height setting. 3. Worn agitator. 4. Clogged nozzle or bag holder. 5. Clogged hose. 6. Hole in hose. 7. Broken/misplaced belt. 8. Hose not inserted fully. 9. Motor protection system activated. 10. Dirty filters. 	<ol style="list-style-type: none"> 1. Change bag. 2. Adjust setting. 3. Replace agitator. 4. Check CLOG REMOVAL. 5. Check for clogs. 6. Replace hose. 7. Replace/fix belt. 8. Insert hose fully. 9. Check for clogs. 10. Change filters.
Vacuum cleaner picks up moveable rugs or pushes too hard.	<ol style="list-style-type: none"> 1. Wrong pile height setting. 	<ol style="list-style-type: none"> 1. Adjust setting.
Light won't work.	<ol style="list-style-type: none"> 1. Burned out light bulb. 	<ol style="list-style-type: none"> 1. Change light bulb.
	<ol style="list-style-type: none"> 1. Broken belt. 2. Bare floor selector in bare floor setting. 3. Belt installed incorrectly. 	<ol style="list-style-type: none"> 1. Replace belt. 2. Move selector to the carpet setting. 3. Check BELT CHANGING AND AGITATOR CLEANING.
Air flow restricted with attachment use. Sound changes.	<ol style="list-style-type: none"> 1. Attachment use restricts air flow. 2. New carpet fuzz clogged air path. 	<ol style="list-style-type: none"> 1. Check ATTACHMENTS. 2. Check CLOG REMOVAL and clean hose.
Excessive noise as vacuum cleaner is shut off.	<ol style="list-style-type: none"> 1. Belt rubbing on carpet/bare floor selector shaft. 	<ol style="list-style-type: none"> 1. Push selector all the way forward.

WARRANTY

Panasonic Vacuum Cleaner Limited Warranty (United States)

Panasonic Consumer Electronics Company (collectively referred to as "the warrantor") will repair this product with new or refurbished parts free of charge, in the U.S.A. or Puerto Rico for one (1) year from the date of original purchase in the event of a defect in materials or workmanship.

This Limited Warranty Excludes both Labor and Parts for the following items which require normal replacement: Disposable Dust Bag, Filters, Belts, Light Bulbs, Agitator Brushes and Batteries (if supplied).

Carry-in or mail-in service in the U.S.A. can be obtained during the warranty period by contacting a Panasonic Services Company (PASC) Factory Servicenter listed in the Servicenter Directory. Or call, toll-free, 1-800-211-PANA (7262) to locate a PASC Authorized Servicenter. Carry-in or mail-in service in Puerto Rico can be obtained during the warranty period by calling the local Panasonic Sales Company telephone number listed in the Servicenter Directory.

This warranty is extended only to the original purchaser. A purchase receipt or other proof of date of original purchase will be required before warranty performance is rendered.

This warranty only covers failures due to defects in materials and workmanship which occur during normal use and does not cover damages which occur in shipment, or failures which are caused by products not supplied by the warrantor, or failures which result from accident, misuse, abuse, neglect, bug infestation, mishandling, misapplication, faulty installation, improper operation or maintenance, alteration, modification, power line surge, improper voltage supply, lightning damage, commercial use such as hotel, office, restaurant or other business or rental use of the product, or service by anyone other than a PASC Authorized Servicenter, or damage that is attributable to acts of God.

LIMITS AND EXCLUSIONS:

There are no express warranties except as listed above.

THE WARRANTOR SHALL NOT BE LIABLE FOR INCIDENTAL OR CONSEQUENTIAL DAMAGES RESULTING FROM THE USE OF THIS PRODUCT, OR ARISING OUT OF ANY BREACH OF THIS WARRANTY. ALL EXPRESS AND IMPLIED WARRANTIES, INCLUDING THE WARRANTIES OF MERCHANTABILITY AND FITNESS FOR A PARTICULAR PURPOSE, ARE LIMITED TO THE APPLICABLE WARRANTY PERIOD SET FORTH ABOVE.

Some states do not allow the exclusion or limitation of incidental or consequential damages, or limitations on how long an implied warranty lasts, so the above exclusions or limitations may not apply to you.

This warranty gives you specific legal rights and you may also have other rights which vary from state to state. If a problem with this product develops during or after the warranty period, you may contact your dealer or Servicenter. If the problem is not handled to your satisfaction, then write to the Consumer Affairs Department at the listed address on the back cover.

WARRANTY

Panasonic Canada Inc.

5770 Ambler drive, Mississauga, Ontario L4W 2T3

PANASONIC PRODUCT - LIMITED WARRANTY

EXCHANGE PROGRAM

Panasonic Canada Inc. warrants this product to be free from defects in material and workmanship and agrees to replace the product for a period as stated below from the date of original purchase.

Vacuum Cleaner - One (1) year

LIMITATIONS AND EXCLUSIONS

This warranty does not apply to products purchased outside Canada or to any product which has been improperly installed, subjected to usage for which the product was not designed, misused or abused, damaged during shipping, or which has been altered or repaired in any way that affects the reliability or detracts from the performance, nor does it cover any product which is used commercially. Parts such as disposable dust bags, filters, belts, light bulbs and agitator brushes are not covered by this warranty. Rechargeable batteries are warranted for ninety (90) days from date of original purchase. This warranty is extended to the original end user purchaser only. A purchase receipt or other proof of date of original purchase is required before warranty service is performed.

THIS EXPRESS, LIMITED WARRANTY IS IN LIEU OF ALL OTHER WARRANTIES, EXPRESS OR IMPLIED, INCLUDING ANY IMPLIED WARRANTIES OF MERCHANTABILITY AND FITNESS FOR A PARTICULAR PURPOSE. IN NO EVENT WILL PANASONIC CANADA INC. BE LIABLE FOR ANY SPECIAL, INDIRECT OR CONSEQUENTIAL DAMAGES.

In certain instances, some jurisdictions do not allow the exclusion or limitation of incidental or consequential damages, or the exclusion of implied warranties, so the above limitations and exclusions may not be applicable.

CONTACT INFORMATION

For product information and operation assistance, please contact:

Our Customer Care Centre:	Telephone #:	(905) 624-5505
	1-800 #:	1-800-561-5505
	Fax #:	(905) 238-2360
	Email link:	"customer support" on www.panasonic.ca

For defective product exchange within the warranty period, please contact the original dealer or our Customer Care Centre.

Vacuum_Xchange warEng_Jan07