

Panasonic®

Operating Instructions Manuel d'utilisation *Instrucciones de operación*

VACUUM CLEANER

Aspirateur

Aspiradora

MC-UL675

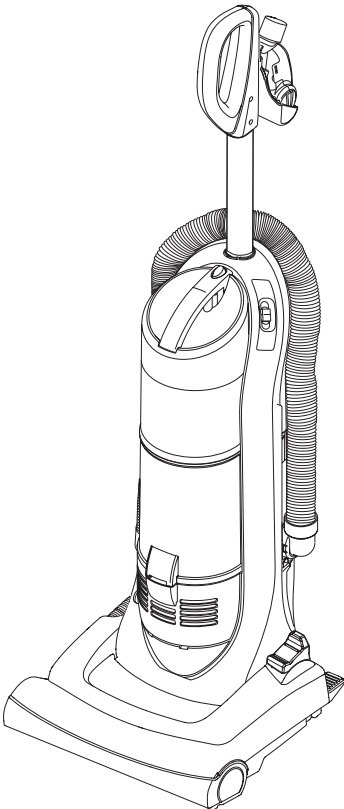

**Before operating your vacuum cleaner,
please read these instructions completely.**

Avant d'utiliser l'appareil, il est recommandé
de lire attentivement ce manuel.

*Antes de usar su aspiradora, lea
completamente estas instrucciones por favor.*

CONSUMER INFORMATION

Please read **IMPORTANT SAFETY INSTRUCTIONS** on page 5 before use. Read and understand all instructions.

TO OUR VALUED CUSTOMER

We are very pleased to welcome you to the Panasonic family of products. Thank you for purchasing this product. Our intent is that you become one of our many satisfied customers.

Proper assembly and safe use of your vacuum cleaner are your responsibilities. Your vacuum cleaner is intended only for household use. The vacuum cleaner should be stored in a dry, indoor area. Read the Operating Instructions carefully for important use and safety information.

Special care is required when vacuuming certain types of carpet or floor covering. Always check the carpet or floor covering manufacturer's recommended cleaning instructions before vacuuming.

PLEASE PAY CLOSE ATTENTION TO ALL WARNING AND CAUTION STATEMENTS.

WARNING

WARNING statements are designed to alert you to the possibility of personal injury, loss of human life, and/or damage to the vacuum cleaner and/or personal property if the instructions given are not followed.

CAUTION

CAUTION statements are designed to alert you to the possibility of damage to the vacuum cleaner and/or personal property if the instructions given are not followed.

WARNING

TO AVOID ELECTRICAL SHOCK

Never vacuum damp or wet surfaces or liquids.
DO NOT store vacuum cleaner outdoors.
Replace worn or frayed power cord immediately.
Unplug from outlet when not in use and before servicing.

TO AVOID ACCIDENTS

Except for hand-held vacuum cleaners, keep vacuum cleaner on floor - not chairs, tables, steps, stairs, etc.
Store vacuum cleaner promptly after each use to prevent accidents such as tripping over power cord or vacuum cleaner.
Use vacuum cleaner and accessories only in a manner intended by the manufacturer.
The use of an extension cord is not recommended.

IMPORTANT SAFETY INSTRUCTIONS

When using your vacuum cleaner, basic precautions should always be followed, including the following:

Read all instructions in this manual before assembling or using your vacuum cleaner.

WARNING To reduce the risk of fire, electrical shock, injury:

1. **Use** your vacuum cleaner only as described in this manual. Use only with Panasonic recommended attachments.
2. **Disconnect** electrical supply before servicing or cleaning out the brush area. Failure to do so could result in the brush unexpectedly starting, causing personal injury from moving parts.
3. **Do not** leave vacuum cleaner when plugged in. Unplug from outlet when not in use and before servicing.
4. **To reduce** the risk of electrical shock - Do not use outdoors or on wet surfaces.
5. **Do not** allow to be used as a toy. Close attention is necessary when used by or near children.
6. **Do not** use with a damaged cord or plug. If vacuum cleaner is not working as it should, has been dropped, damaged, left outdoors, or dropped in water, return it to a Panasonic Service Center.
7. **Do not** pull or carry by cord, use cord as a handle, close a door on cord, or pull cord around sharp edges or corners. Do not run vacuum cleaner over cord. Keep cord away from heated surfaces.
8. **Do not** unplug by pulling on cord. To unplug, grasp the plug, not the cord.
9. **Do not** handle plug or vacuum cleaner with wet hands.
10. **Do not** put any objects into openings.
11. **Do not** use with any opening blocked; keep free of dust, lint, hair, and anything that may reduce air flow.
12. **Keep** hair, loose clothing, fingers, and all parts of body away from openings and moving parts.
13. **Turn off** all controls before unplugging.
14. **Use** extra care when cleaning on stairs. Do not put on chairs, tables, etc. Keep on floor.
15. **Do not** use vacuum cleaner to pick up flammable or combustible liquids (gasoline, cleaning fluid, perfumes, etc.), or use in areas where they may be present. The fumes from these substances can create a fire hazard or explosion.
16. **Do not** pick up anything that is burning or smoking, such as cigarettes, matches, or hot ashes.
17. **Do not** use vacuum cleaner without dust bin and/or filters in place.
18. **Unplug** before connecting Air Turbine.
19. **Hold** plug when rewinding onto cord reel. Do not allow plug to whip when rewinding.
20. **Do not** operate vacuum cleaner without the exhaust filter or exhaust filter cover in place.
21. **You are** responsible for making sure that your vacuum cleaner is not used by anyone unable to operate it properly.

SAVE THESE INSTRUCTIONS

THIS VACUUM CLEANER IS INTENDED FOR HOUSEHOLD USE ONLY

NOTE: Before you plug in your Panasonic vacuum cleaner, make sure that the voltage indicated on the rating plate located at the back of the vacuum cleaner is the same as your local electrical supply.

TABLE OF CONTENTS

CONSUMER INFORMATION	2
IMPORTANT SAFETY	
INSTRUCTIONS	5
PARTS IDENTIFICATION	10,11
FEATURE CHART	11
ASSEMBLY	12
Attaching Components	12
Using Cord Reel	12
FEATURES	14
Adjustable Handle	14
Automatic Self Adjusting Nozzle	14
Edge Cleaning	14
Filter Cleaning System	16
Cord Hook	16
TO OPERATE VACUUM CLEANER	18
Power Cord	18
ON / OFF Switch	18
Using Adjustable Handle	18
Using Tools with Removable Hose	20
Body Release	22
Carpet-Bare Floor Selector	24
Attachments	26
Dirt Sensor	28
Performance Indicator	30
To Clean Dirt Sensor Optics	30
Dust Bin Cleaning	32
Filter Changing and Cleaning	34
To Clean the Pre-filter	36
Motor Protector	38
ROUTINE CARE OF VACUUM CLEANER	40
Cleaning Secondary Filter Screen	40
Replacing HEPA Exhaust Filter	42
Cleaning Agitator	44
Thermal Protector	44
Removing and Installing Lower Plate	46
Replacing Belt	48
Replacing Headlight Bulb	50
Cleaning Exterior and Tools	52
Removing Clogs	54
BEFORE REQUESTING SERVICE	56
WARRANTY	59,60
WHAT TO DO WHEN SERVICE IS NEEDED	64

PARTS IDENTIFICATION

Nomenclature

Identificación de piezas

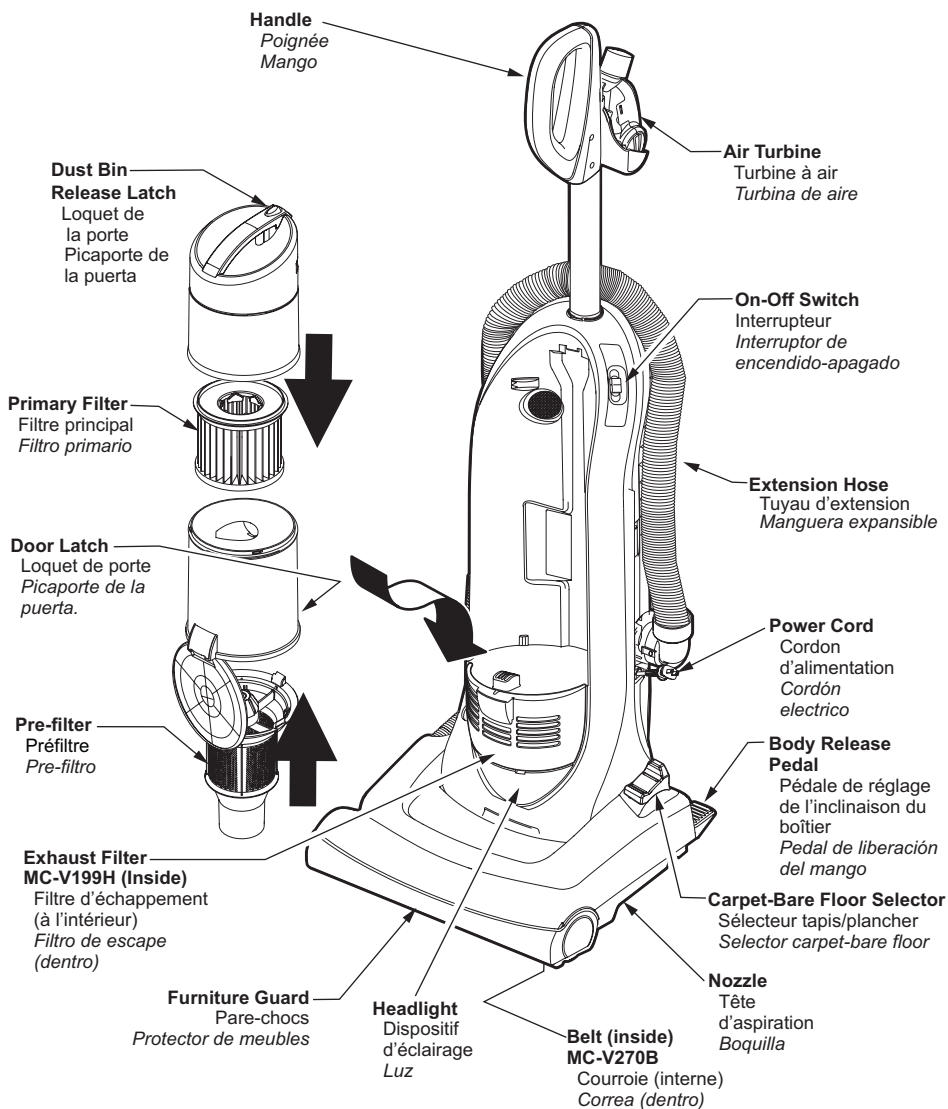

ASSEMBLY

Attaching Components

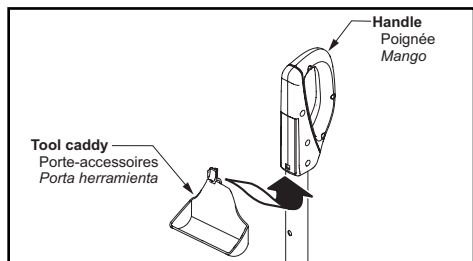

CAUTION

DO NOT plug in until assembly is complete.

- Slide the tool caddy into the handle slots and push upward until a locking click is produced.

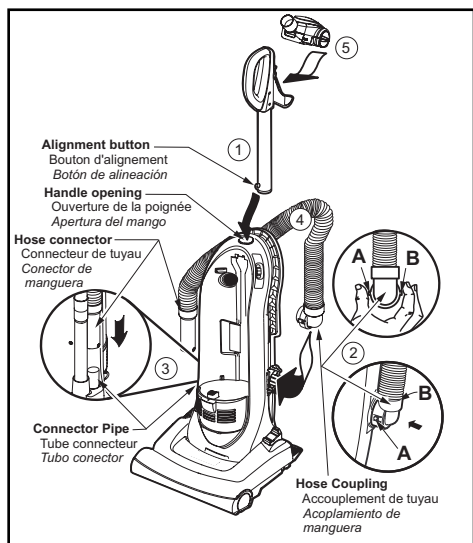

- Insert adjustable handle assembly as illustrated.
- Attach hose end to vacuum cleaner as illustrated.
- Insert hose onto connector pipe.
- Place extension hose on hose holder.
- Insert air turbine into holder on vacuum cleaner handle as indicated.

Using Cord Reel

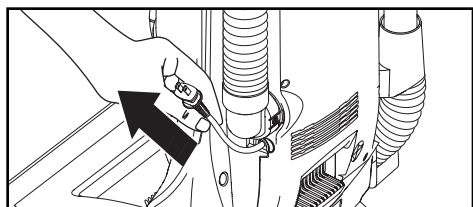

- Do not use vacuum cleaner without cord pulled out all the way.

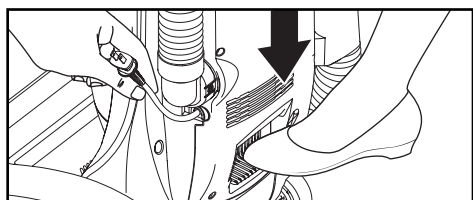

FEATURES

Adjustable Handle

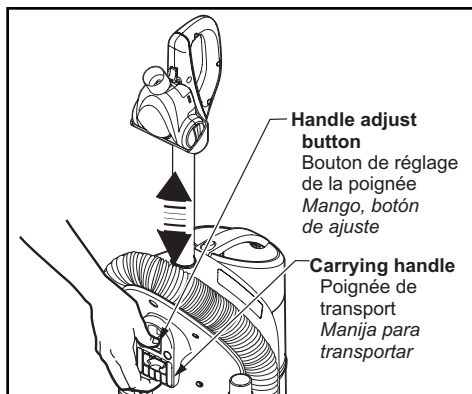

- Press Handle Adjust button and raise handle to a comfortable operating position. You should hear a click to ensure handle is secure in position.

CAUTION

DO NOT carry the vacuum cleaner by the adjustable handle or dust bin handle. Use **ONLY** the carrying handle located on the back of the vacuum cleaner.

Automatic Self Adjusting Nozzle

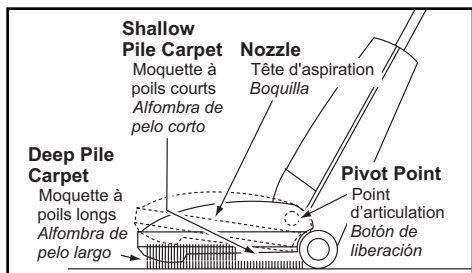

- The nozzle of your Panasonic vacuum cleaner automatically adjusts to any carpet pile height.
- Feature allows nozzle to float evenly over carpet pile surfaces.
- No manual adjustments required.

Edge Cleaning

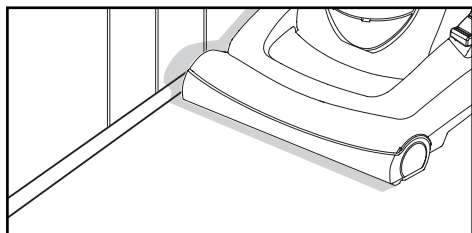

- Edge cleaning feature enables improved cleaning of carpets near walls and furniture.

Filter Cleaning System

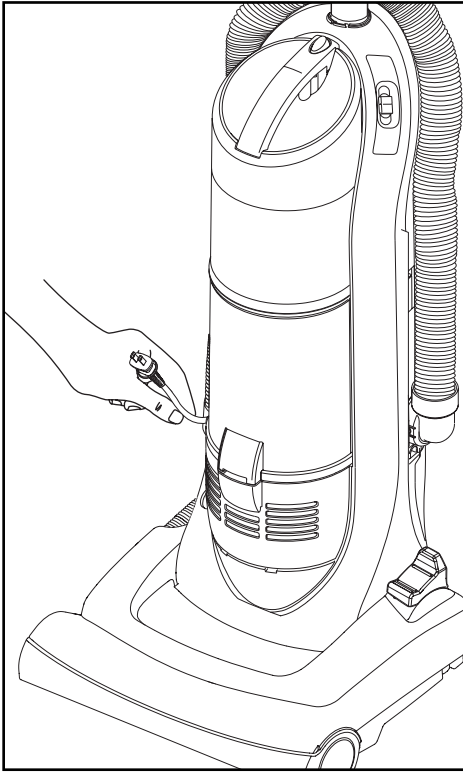

Your Panasonic vacuum cleaner is equipped with the latest technology.

- Filter Cleaning System is activated by the cord reel.
- Each time the power cord is pulled out the filter is cleaned.
- Before use, pull power cord out until the end is reached

NOTE:

DO NOT use vacuum cleaner if power cord is not pulled out to the end.

Cord Hook

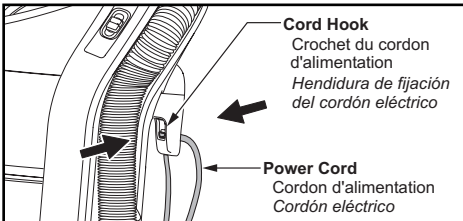

- Make sure the power cord is placed into the cord hook as shown.

Note: This helps keep the power cord out from under the vacuum cleaner agitator.

TO OPERATE VACUUM CLEANER

Power Cord

Note: To reduce the risk of electrical shock, this vacuum cleaner has a polarized plug, one blade is wider than the other. This plug will fit in a polarized outlet only one way. If the plug does not fit fully in the outlet, reverse the plug. If it still does not fit, contact a qualified electrician to install the proper outlet. **DO NOT CHANGE THE PLUG IN ANY WAY.** Only use outlets near the floor.

ON / OFF Switch

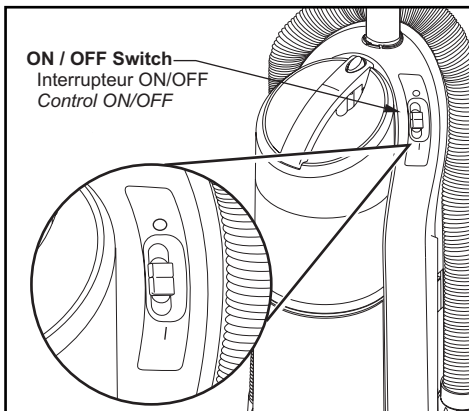

- Ensure “I/O” switch is OFF “O”
- Plug the power cord into 120V outlet
- “I” position turns vacuum cleaner on.
- “O” position turns vacuum cleaner off.

Using the Adjustable Handle

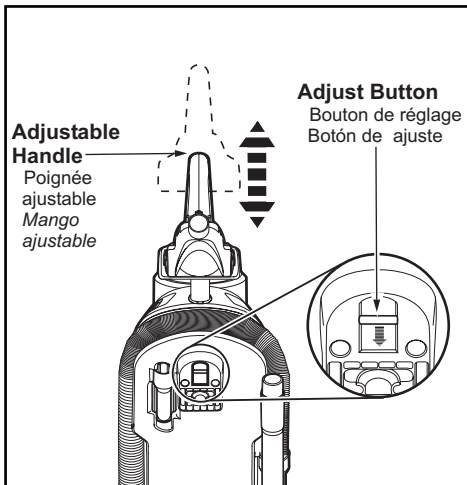

- Press the HANDLE ADJUST button located on the back of the vacuum cleaner.
- Raise or lower the adjustable handle to the desired operating position. You should hear a click to ensure handle is secure in position.

CAUTION

DO NOT carry the vacuum cleaner by the adjustable handle. Use **ONLY** the carrying handle located on the back of the vacuum cleaner.

Using Tools with Removable Hose

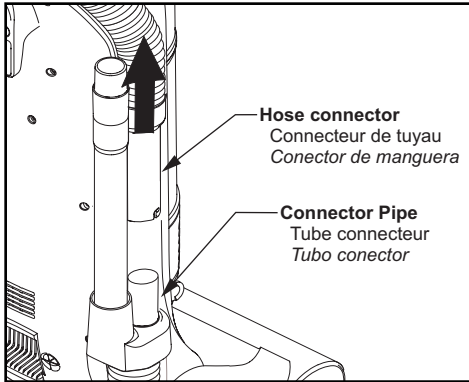

- To remove hose from connector pipe; grasp hose by the hose connector and slide off of connector pipe.
- With the hose free from the connector pipe, it now can be used to add attachments.

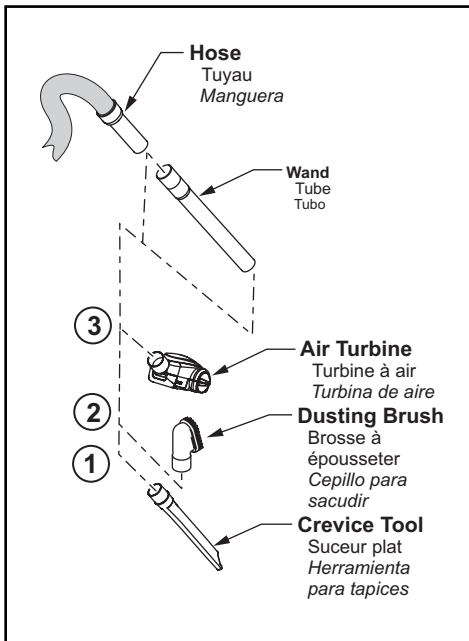

- Add attachments to suit your cleaning needs.
- The Crevice Tool ① may be used on the following items:
 - Furniture
 - Cushions
 - Drapes
 - Stairs
 - Walls
- The Dusting Brush ② may be used on the following items:
 - Furniture
 - Drapes
 - Stairs
 - Walls
- The Panasonic Air Turbine ③ may be used on the following items:
 - Furniture
 - Stairs
 - Floors
- To reinstall hose to connector pipe slide hose connector onto connector pipe and push down to a press fitting.

Body Release

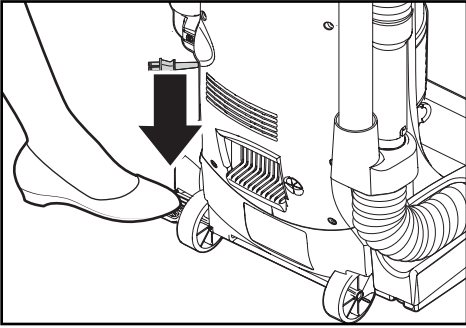

- Your vacuum cleaner is equipped with three (3) position body release;
 - Upright position (locked)
 - Middle position (normal use)
 - Low position (getting under furniture)

- Release the body by pressing down on the body release pedal with your foot and pulling back and down on the handle with your hand.

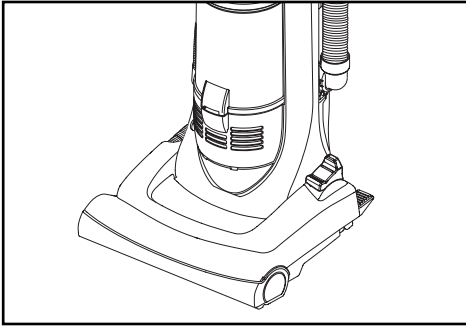

- Move the vacuum cleaner to upright position for storage and tool use.

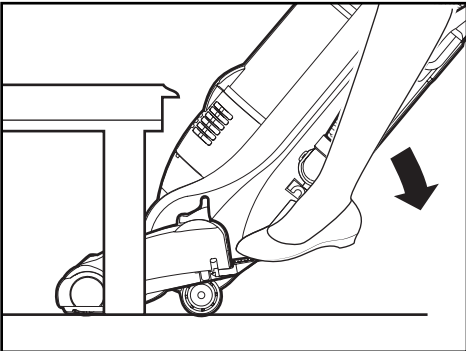

- Move the vacuum cleaner to middle position for normal use.

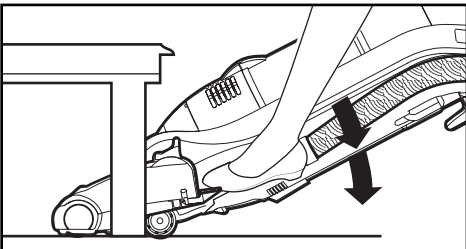

- To move the vacuum cleaner to the low position press the body release pedal again.

Carpet/Bare Floor Selector

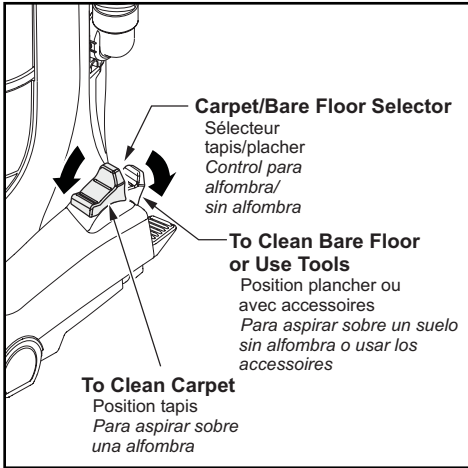

- Selector should be placed in **BARE FLOOR (TOOLS)** position when using vacuum cleaner on bare floors and when using tools. The agitator does not rotate in the **BARE FLOOR (TOOLS)** position.
- Selector should be placed in **CARPET** position when using vacuum cleaner on carpeted floors.

NOTE: For longer belt life, turn vacuum cleaner off before moving selector.

- Otherwise, take care when selecting either position to ensure selector is pushed as fully and quickly as possible to desired position.
- Failure to do so can cause belt to rub on selector shaft and result in belt becoming hot and creating a burning rubber smell.



NOTE: When using attachments make sure the vacuum cleaner is in the upright position and the Carpet/ Bare Floor selector is in the **BARE FLOOR** position.

CAUTION:

While using the accessories, hold the handle with one hand to avoid pulling the vacuum cleaner over.

Attachments

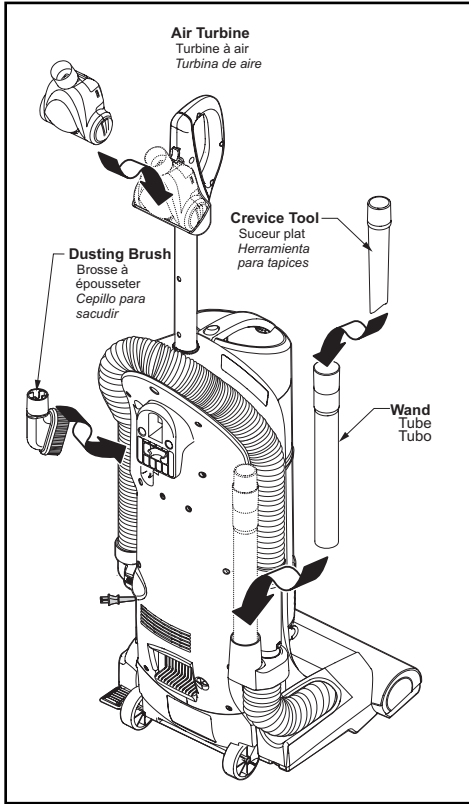

Identify each of the attachments shown.

Note: The motor protector may open when using attachments or when cleaning new carpet, due to reduced airflow by the attachments themselves or by new carpet lint filling the dust bin quickly.

Note: When using attachments make sure the vacuum cleaner is in the upright position and the Carpet/ Bare Floor selector is in the BARE FLOOR position.

- Remove the upper end of the hose that is attached to the connector pipe by grasping the hose connector, twisting and pulling straight out. The attachments can now be added to the hose.
- Remove dusting brush from the vacuum cleaner. Place back in its appropriate storage location.
- Remove extension wand from the side of the vacuum cleaner. Place back in its appropriate storage location.
- Remove crevice tool from inside of the wand. Place back in its appropriate storage location.
- Remove Air Turbine from the vacuum cleaner. Place back in its appropriate storage location.

Dirt Sensor

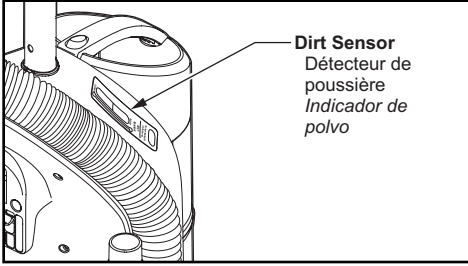

- The electronic dirt sensor is a feature which will detect particles as they pass through the vacuum cleaner.
- The dirt sensor indicator is located on the front of the vacuum cleaner as illustrated.

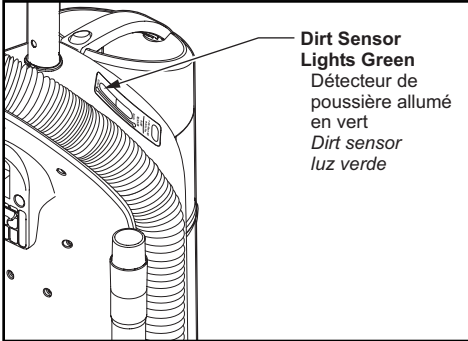

- When there is little or no dirt present the dirt sensor is green.

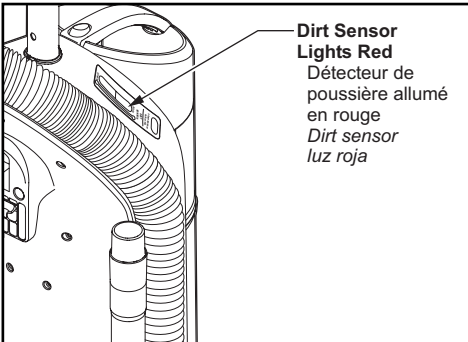

- When there is dirt present the dirt sensor is red.

Performance Indicator

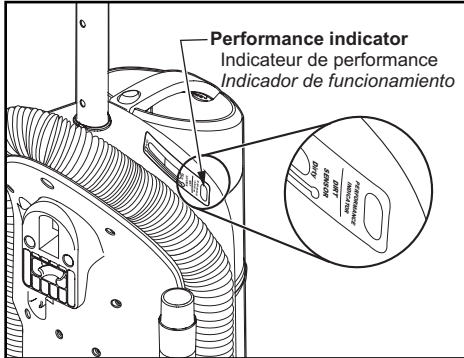

- When the vacuum cleaner is running with normal air flow, the light on the performance indicator is off. The light comes on whenever the airflow becomes blocked. If that occurs, check the dust bin clean/replace clogged filters, and check other possible clog locations shown in **CLOG REMOVAL**. The light may also come on when using attachments, due to reduced airflow through the attachment. In some cases, the performance indicator light may not come on if the motor protector has opened.

To Clean Dirt Sensor Optics

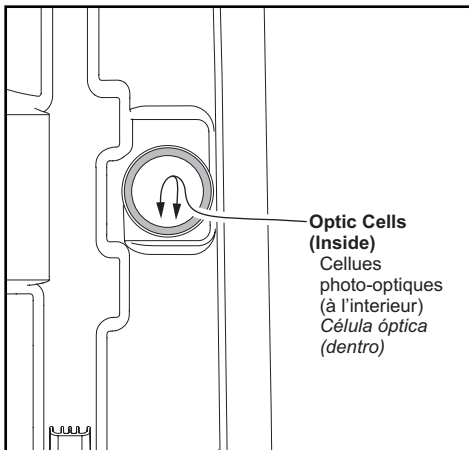

- The dirt sensor optics consist of two optic cells located inside the suction inlet. Occasionally, it may become necessary to clean the two optic cells to assure maximum performance.
- Clean optic cells:
 - When dirt or dust adheres to the optic cells.
 - Whenever the dust bin is cleaned.
- To clean the dirt sensor optics, remove the dust bin.
- With the dust bin removed you can insert a cloth into the suction inlet opening.
- Wipe the optic cells with a soft, dry cloth.
- Never use cleaners or liquids as they can help speed the recoating of the optic cells and make it necessary to clean them much sooner than normal.

Dust Bin Cleaning

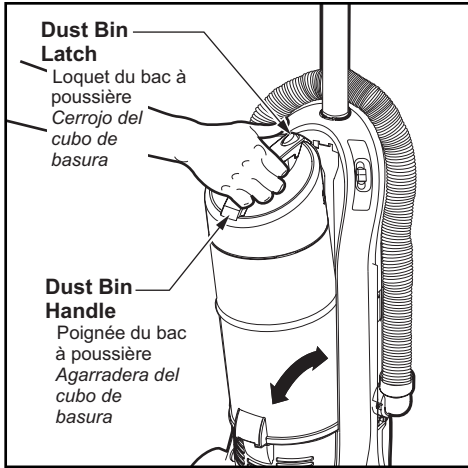

- Always empty the dust bin when dirt level reaches the “MAX” line.
- Grasp the handle on the top of the dust bin. Push the dust bin latch down. Pull out and up to remove dust bin from vacuum cleaner.

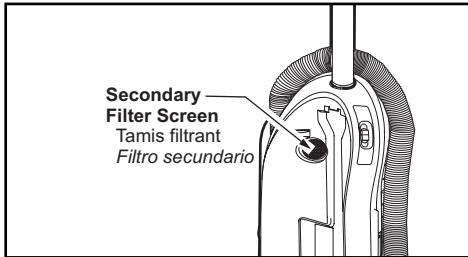

- Remove any clogs that might be located in the filter screen.

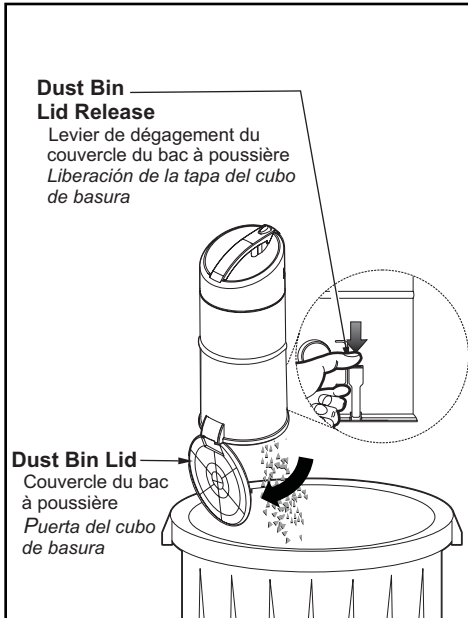

CAUTION

Be sure to hold the dust bin over a proper trash container prior to releasing the door of the dust bin.

- Press dust bin lid release and the dust bin will open. The debris will fall out.

Filter Changing and Cleaning

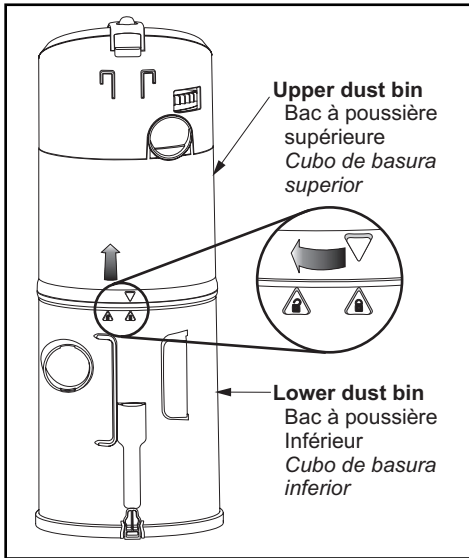

- Check primary filter frequently and clean when dirty.
- To remove primary filter, open upper dust bin lid assembly. Turn the upper dust bin to the unlock position as shown.
- While holding primary filter over a trash container grasp filter, push sideways and remove filter from upper dust bin.
- Clean primary filter by gently tapping over a trash container. Tap on several sides to ensure best cleaning.
- Rinse with water only as needed. Do not use any detergent or soap.

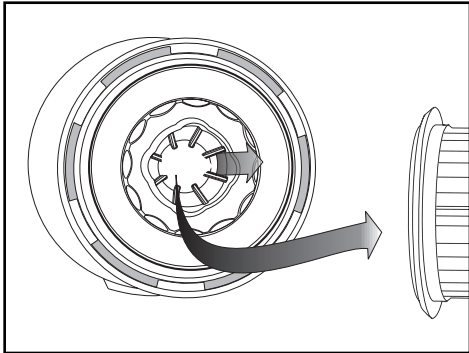

- Allow the filter to dry for 24 hours before putting it back into the vacuum cleaner.
- When cleaning the filter no longer restores vacuum cleaner suction to full power you need to replace the filter.

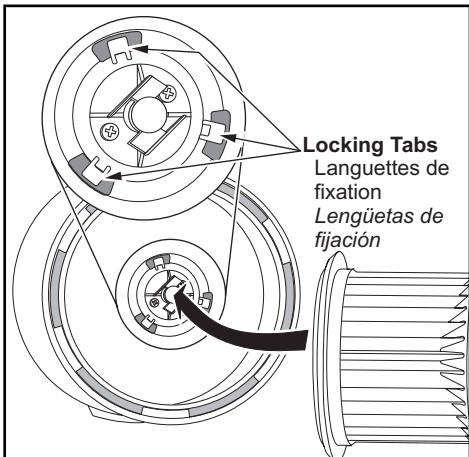

TO REPLACE PRIMARY FILTER

- With slot side on filter facing the dust bin, slide the filter's opening over the cleaning cam, and then push filter until it locks onto tabs in dust bin.

Note: Under normal use and care, your filter can be expected to last up to 5 years.

To Clean the Pre-filter

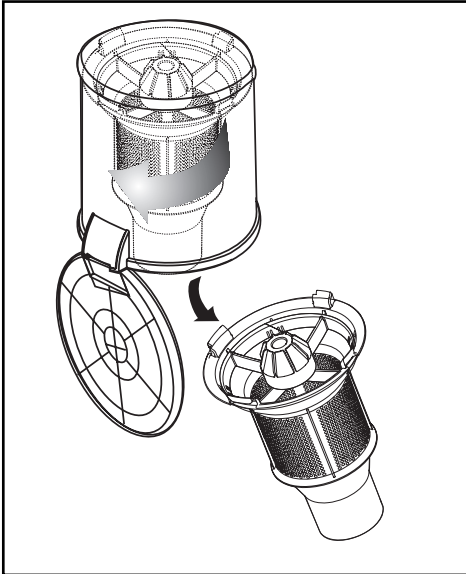

- Turn clockwise and pull the pre-filter. Clean by gently tapping over a trash container.
- Return the pre-filter to the dust bin, aligning the pre-filter tabs to the lower dust bin slots, then turn counter-clockwise to the lock position.
- After the dust bin is empty of debris, firmly close the door. Make sure you hear a “click” sound to indicate that the door is fully latched.
- Reassemble upper and lower dust bins. Place dust bin unit back into vacuum cleaner by inserting the bottom first and tilting back.

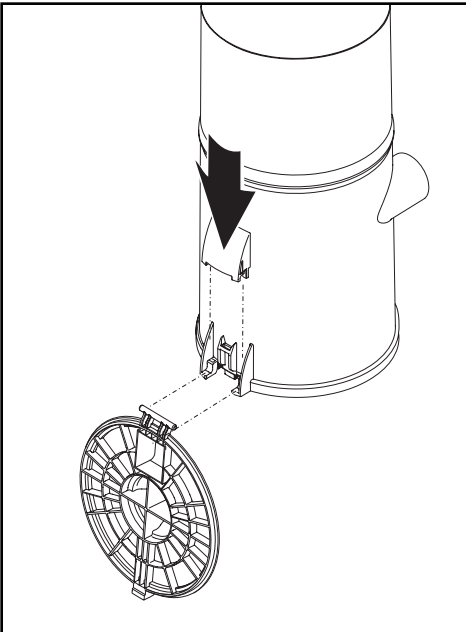

- A retention clip is located on the hinge area of the dust bin.
- This clip may release when the dust bin door is opened to prevent damage to the door or the dust bin.
- To reassemble, slide the tabs on the dust bin door into the slots on the dust bin.
- Secure in place using the retention clip.

Motor Protector

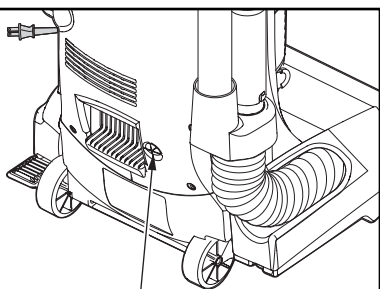

Motor Protector
Protecteur du moteur
Protector de motor

- Automatically opens to provide cooling air to the motor when a clog occurs or when dust bin needs emptying.
- Motor protector may open when using tools.
- Check operation by placing hand over end of hose.
- If motor protector opens, the vacuum cleaner will make a slightly different sound.
- Do not block motor protector.

ROUTINE CARE OF VACUUM CLEANER

Performing the following tasks will keep your new Panasonic vacuum cleaner operating at peak performance levels and will ensure these high levels for years to come. Check the **BEFORE REQUESTING SERVICE** section in this manual for recommendations on performing some of these tasks to help solve various problems that may occur.

WARNING Electrical Shock or Personal Injury Hazard

Disconnect the electrical supply before servicing or cleaning the vacuum cleaner. Failure to do so could result in electrical shock or personal injury from vacuum cleaner suddenly starting.

Cleaning Secondary Filter Screen

Secondary
Filter Screen
Tamis filtrant
Filtro secundario

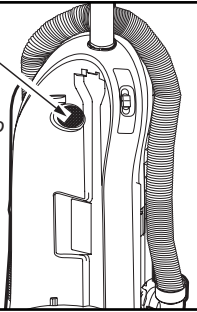

- The secondary filter screen protects the motor.
- Always check filter screen when cleaning dust bin.
- If dirty or clogged, remove debris from filter screen.

Replacing HEPA Exhaust Filter

Press Release Tab

Appuyer sur la languette de dégagement
Presione lengüetas de liberación

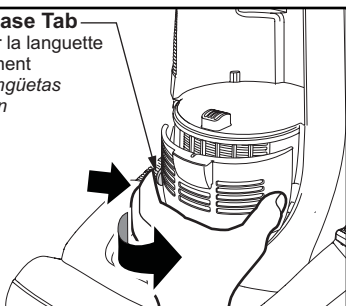

- The HEPA exhaust filter removes dirt from exhaust air.
- Check filter after emptying dust bin. Replace when dirty.
- To remove exhaust filter cover, press on release tab and rotate off.

Exhaust Filter

Filtere d'évacuation
Filtro de salida

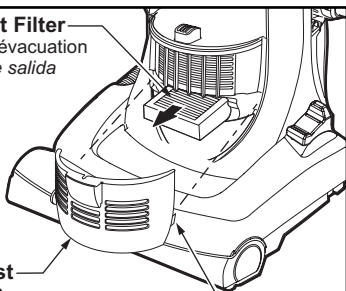

Exhaust Filter Cover

Couvercle du filtre d'évacuation
Cubierta de filtro de salida

Tab

Languette
Lengüeta

- Grasp the exhaust filter and pull out to remove.
- Ensure foam edge of the filter is facing down when placing filter into filter compartment.

Exhaust Filter

Filtere d'évacuation
Filtro de salida

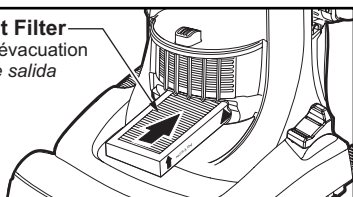

- Ensure that Air Flow arrows are pointing upward.

Release Tab

Languette de dégagement
Lengüetas de liberación

Slot
Fente
Lengüeta

Tab
Languette
Lengüeta

Exhaust Filter Cover

Couvercle du filtre d'évacuation
Cubierta de filtro de salida

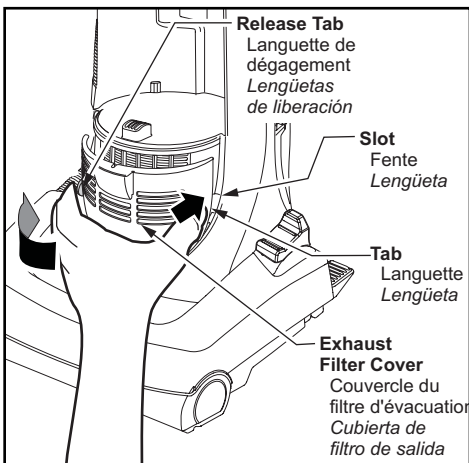

- Reinstall exhaust filter cover by placing the tab on the cover into the slot on the body and snapping into place.

WARNING

Do not operate vacuum cleaner with a clogged exhaust filter or without the exhaust filter cover installed.

- * Filter cannot be cleaned and should be replaced at least once each year.

Cleaning Agitator

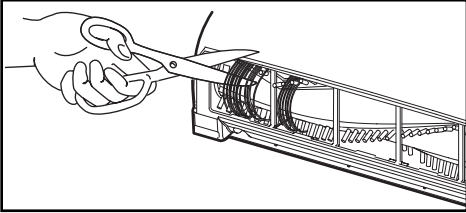

- Clean agitator after every five uses.
- Turn vacuum cleaner over, exposing the agitator.
- Cut off any carpet pile and lint entangled around agitator with a pair of scissors.

Thermal Protector

- If a clog prevents the normal flow of air to the motor, the thermal protector turns the motor off automatically to allow the motor to cool in order to prevent possible damage to the vacuum cleaner.
- To correct problem, turn off and unplug the vacuum cleaner, remove clogs and/or clean/replace filters.
- Empty dust bin if necessary.
- Wait approximately thirty (30) minutes, plug vacuum cleaner in, turn on to see if thermal protector has reset. Thermal protector will not reset if the vacuum cleaner is not unplugged even if vacuum cleaner cools down.

WARNING Electrical Shock or Personal Injury Hazard

Disconnect the electrical supply before servicing or cleaning the vacuum cleaner. Failure to do so could result in electrical shock or personal injury from vacuum cleaner suddenly starting.

Removing and Installing Lower Plate

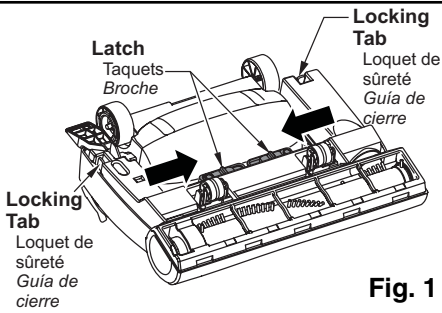

- **Before servicing any parts, disconnect vacuum cleaner from electrical outlet.**
- **Always place paper under nozzle whenever lower plate is removed to protect floor.**
- **Place body in upright position and turn vacuum cleaner over to expose lower plate.**
- **Release lower plate by pressing two (2) latches and two (2) locking tabs inward as shown. (Fig. 1)**

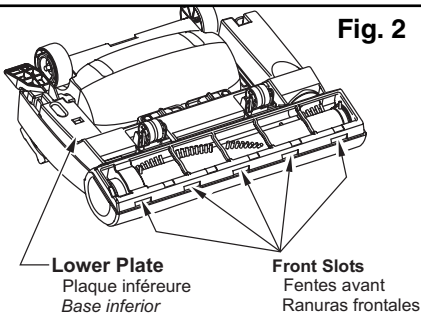

- **Remove lower plate and remove any residue that may exist in belt area.**
- **Reinstall lower plate by hooking front end of lower plate into slots on front of nozzle housing. (Fig. 2)**

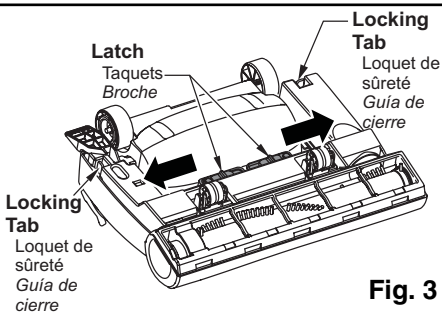

- **Rotate lower plate until locking tabs snap into place then push the two (2) latches outward. (Fig. 3)**

Replacing Belt

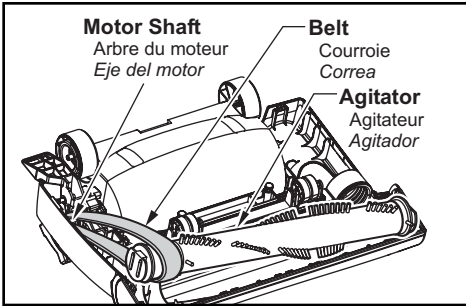

➤ Replace belt whenever a burning rubber smell caused by excessive slippage occurs.

➤ Place carpet-bare floor selector in CARPET position.

➤ Remove lower plate.

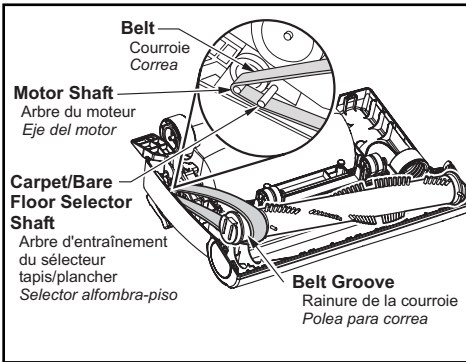

➤ Remove agitator by carefully lifting out.

➤ Remove worn or broken belt.

➤ Loop new belt around motor shaft and brush pulley; see illustration for correct belt routing.

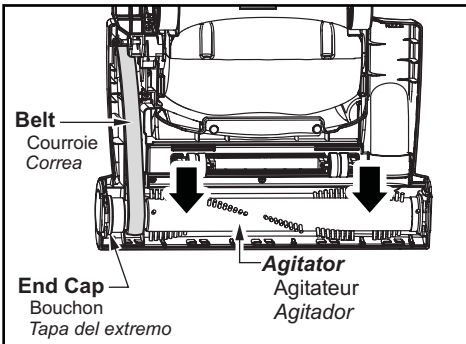

➤ Clean agitator and reinstall the two (2) end caps.

➤ Reinstall agitator back into nozzle housing grooves.

➤ After reinstalling the agitator, turn it by hand to make sure the belt is not twisted or pinched and that all rotating parts turn freely.

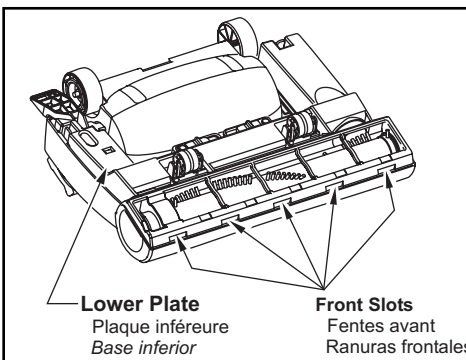

➤ Reinstall lower plate. Ensure tabs are locked into slots.

Replacing Headlight Bulb

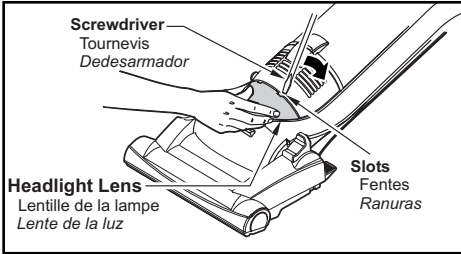

- Disconnect power cord from electrical outlet. Lower body to lay the vacuum cleaner flat.
- Pry out light lens at slots by inserting screwdriver into slot, pushing down on the lens and rotating the screwdriver handle toward vacuum cleaner.

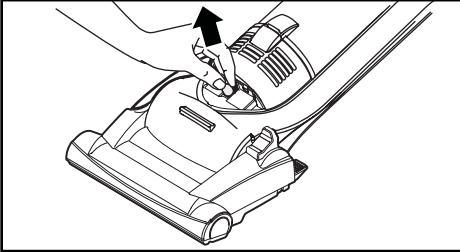

- Remove the light bulb by pulling straight out.

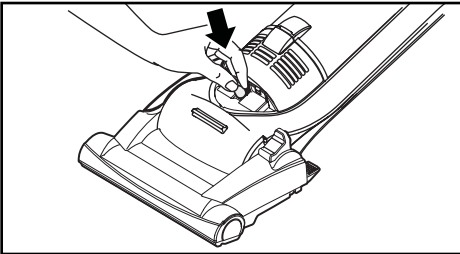

- To replace the light bulb carefully insert securely into slot. Replace lens cover.

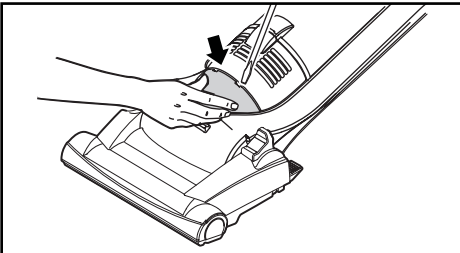

- A “popping” sound indicates lens is snapped properly in place.

CAUTION

Do not use a bulb rated over 9W (13V). During extended use, heat from the bulb could overheat surrounding plastic parts.

- Replace lens cover by inserting bottom tab of lens into slot then applying pressure to top tabs.

Cleaning Exterior and Tools

- **Unplug cord from wall outlet.**
- **Clean exterior using a clean, soft cloth that has been dipped in a solution of mild liquid detergent and water and wrung dry.**
- **DO NOT drip water on the vacuum cleaner and wipe dry after cleaning.**
- **DO NOT clean tools in dishwasher or clothes washer.**
- **Wash tools in warm soapy water, rinse and air dry.**
- **DO NOT use tools if they are wet.**

Removing Clogs

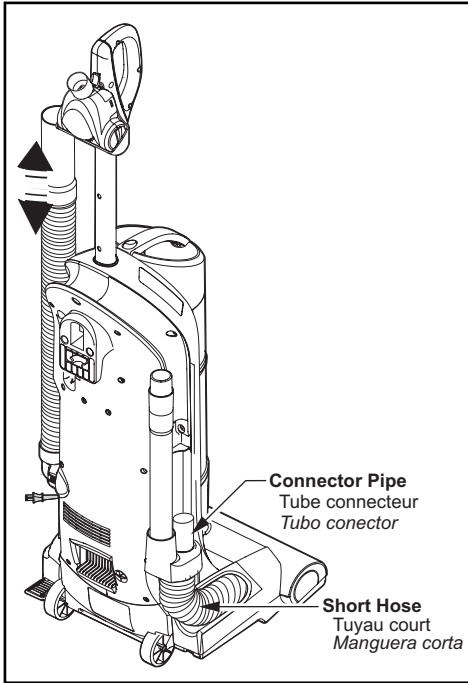

If the vacuum cleaner does not seem to have adequate suction, first check if the dust bin is full or if a filter is clogged.

- Check the hose area.
- Remove extension hose by grasping the hose collar, twisting, and pulling straight off.
- Visually inspect the hose and the base area into which the hose is connected.
- Remove any visible clog.
- Re-connect the extension hose to the connector pipe.

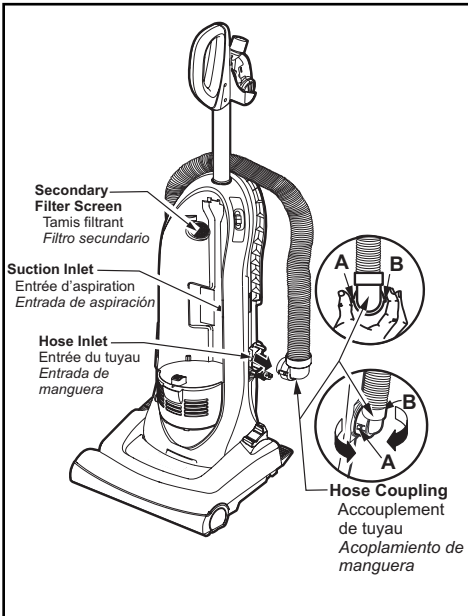

- Plug in the vacuum cleaner and turn it on.
- Stretch the hose to maximum length and then allow the hose to return to its storage length.
- Turn off and unplug the vacuum cleaner.
- Remove dust bin and check secondary filter screen for clogs.
- If the dust bin, filter areas and the hose areas are free of clogs, check the nozzle area.
- Return the vacuum cleaner to the upright position before plugging into an electrical outlet.

BEFORE REQUESTING SERVICE



WARNING Electrical Shock or Personal Injury Hazard

Disconnect the electrical supply before servicing or cleaning the vacuum cleaner. Failure to do so could result in electrical shock or personal injury from vacuum cleaner suddenly starting.

Review this chart to find do-it-yourself solutions for minor performance problems. Any service needed, other than those described in these Operating Instructions, should be performed by an authorized service representative.

PROBLEM	POSSIBLE CAUSE	POSSIBLE SOLUTION
Vacuum Cleaner won't run.	<ol style="list-style-type: none"> 1. Unplugged at wall outlet. 2. Tripped circuit breaker/blown fuse at household service panel. 3. Thermal protector tripped. 	<ol style="list-style-type: none"> 1. Plug in firmly, turn on vacuum cleaner. 2. Reset circuit breaker or replace fuse. 3. Unplug vacuum cleaner, allow to cool and thermal protector will reset itself.
Poor job of dirt pick-up.	<ol style="list-style-type: none"> 1. Full or clogged dust bin. 2. Worn agitator. 3. Clogged nozzle. 4. Clogged hose. 5. Hole in hose. 6. Hose not inserted fully 7. Motor protection system activated. 8. Dirty filters. 	<ol style="list-style-type: none"> 1. Empty dust bin. 2. Take to your nearest Panasonic Service Center. 3. Check for clogs. 4. Check for clogs. 5. Take to your nearest Panasonic Service Center. 6. Check hose connection 7. Check for clogs. 8. Change primary filter and exhaust filter.
Light won't work.	<ol style="list-style-type: none"> 1. Burned out light bulb. 	<ol style="list-style-type: none"> 1. Change light bulb.
Agitator does not turn.	<ol style="list-style-type: none"> 1. Carpet/Bare floor selector in Bare Floor 2. Broken belt. 	<ol style="list-style-type: none"> 1. Move selector to the Carpet position. 2. Replace belt.
Air flow restricted with attachment use. Sound changes.	<ol style="list-style-type: none"> 1. Attachment use restricts air flow. 2. New carpet fuzz clogged air path. 	<ol style="list-style-type: none"> 1. See ATTACHMENTS. 2. See CLOG REMOVAL and clean hose.
Dirt Sensor will not work.	<ol style="list-style-type: none"> 1. Dirty optic cells. 	<ol style="list-style-type: none"> 1. Clean optic cells.

WARRANTY

Panasonic Vacuum Cleaner Limited Warranty (United States)

Panasonic Consumer Electronics Company (collectively referred to as "the warrantor") will repair this product with new or refurbished parts free of charge, in the U.S.A. or Puerto Rico for one (1) year from the date of original purchase in the event of a defect in materials or workmanship.

This Limited Warranty Excludes both Labor and Parts for the following items which require normal replacement: Disposable Dust Bag, Filters, Belts, Light Bulbs, Agitator Brushes and Batteries (if supplied).

Carry-in or mail-in service in the U.S.A. can be obtained during the warranty period by contacting a Panasonic Services Company (PASC) Factory Servicenter listed in the Servicenter Directory. Or call, toll free, 1-800-211-PANA (7262) to locate a PASC Authorized Servicenter. Carry-in or mail-in service in Puerto Rico can be obtained during the warranty period by calling the local Panasonic Sales Company telephone number listed in the Servicenter Directory.

This warranty is extended only to the original purchaser. A purchase receipt or other proof of date of original purchase will be required before warranty performance is rendered.

This warranty only covers failures due to defects in materials and workmanship which occur during normal use and does not cover damages which occur in shipment, or failures which are caused by products not supplied by the warrantor, or failures which result from accident, misuse, abuse, neglect, mishandling, misapplication, faulty installation, improper operation or maintenance, alteration, modification, power line surge, improper voltage supply, lightning damage, commercial use such as hotel, office, restaurant or other business or rental use of the product, or service by anyone other than a PASC Authorized Servicenter, or damage that is attributable to acts of God.

LIMITS AND EXCLUSIONS:

There are no express warranties except as listed above.

THE WARRANTOR SHALL NOT BE LIABLE FOR INCIDENTAL OR CONSEQUENTIAL DAMAGES RESULTING FROM THE USE OF THIS PRODUCT, OR ARISING OUT OF ANY BREACH OF THIS WARRANTY. ALL EXPRESS AND IMPLIED WARRANTIES, INCLUDING THE WARRANTIES OF MERCHANTABILITY AND FITNESS FOR A PARTICULAR PURPOSE, ARE LIMITED TO THE APPLICABLE WARRANTY PERIOD SET FORTH ABOVE.

Some states do not allow the exclusion or limitation of incidental or consequential damages, or limitations on how long an implied warranty lasts, so the above exclusions or limitations may not apply to you.

This warranty gives you specific legal rights and you may also have other rights which vary from state to state. If a problem with this product develops during or after the warranty period, you may contact your dealer or Servicenter. If the problem is not handled to your satisfaction, then write to the Consumer Affairs Department at the listed address on the back cover.

WARRANTY

Panasonic Canada Inc.

PANASONIC PRODUCT - LIMITED WARRANTY

Panasonic Canada Inc. warrants this product to be free from defects in material and workmanship and agrees to remedy any such defect for a period as stated below from the date of original purchase.

Vacuum Cleaner - One (1) year, parts and labour

LIMITATIONS AND EXCLUSIONS

This warranty does not apply to products purchased outside Canada or to any product which has been improperly installed, subjected to usage for which the product was not designed, misused or abused, damaged during shipping, or which has been altered or repaired in any way that affects the reliability or detracts from the performance, nor does it cover any product which is used commercially. Parts such as disposable dust bags, filters, belts, light bulbs and agitator brushes are also excluded from coverage under this warranty. A purchase receipt or other proof of date of original purchase is required before warranty service is performed.

THIS EXPRESS, LIMITED WARRANTY IS IN LIEU OF ALL OTHER WARRANTIES, EXPRESS OR IMPLIED, INCLUDING ANY IMPLIED WARRANTIES OF MERCHANTABILITY AND FITNESS FOR A PARTICULAR PURPOSE. IN NO EVENT WILL PANASONIC CANADA INC. BE LIABLE FOR ANY SPECIAL, INDIRECT OR CONSEQUENTIAL DAMAGES.

In certain instances, some jurisdictions do not allow the exclusion or limitation of incidental or consequential damages, or the exclusion of implied warranties, so the above limitations and exclusions may not be applicable.

WARRANTY SERVICE

FOR PRODUCT OPERATION ASSISTANCE, please contact:

Our Customer Care Centre:	Telephone #:	(905) 624-5505
	1-800 #:	1-800-561-5505
	Fax #:	(905) 238-2360
	Email link:	"Contactez-nous" sous "Support à la clientèle" on www.panasonic.ca

FOR PRODUCT REPAIRS, please locate your nearest Authorized Servicentre at www.panasonic.ca :

Link : "ServicentresTM locator" under "Customer support"

IF YOU SHIP THE PRODUCT TO A SERVICENTRE

Carefully pack and send prepaid, adequately insured and preferably in the original carton.
Include details of the defect claimed, and proof of date of original purchase.

Ref: VACwar Eng_Apr06

WHAT TO DO WHEN SERVICE IS NEEDED

If your Panasonic Vacuum Cleaner needs service, look in the yellow pages of the telephone book under HOME APPLIANCE SERVICE for your nearest Panasonic Services Company ("PASC") Factory Servicenter, or PASC authorized Servicenter, or call, 1-800-211-PANA (7262) toll free to find a convenient servicenter. **DO NOT** send the product to the Executive or Regional Sales offices. They are NOT equipped to make repairs.

If you ship the product

Carefully pack and send it prepaid, adequately insured and preferably in the original carton. Attach a postage-paid letter to the outside of the carton, which contains a description of your complaint. **DO NOT** send the product to the Executive or Regional Sales Offices. They are NOT equipped to make repairs.

PANASONIC CONSUMER ELECTRONICS COMPANY
DIVISION OF PANASONIC CORPORATION OF NORTH AMERICA

One Panasonic Way
Secaucus, New Jersey 07094
World Wide Web Address
<http://www.panasonic.com>

What to do when service is needed Service après-vente (Canada)

WARRANTY SERVICE

For product operation and information assistance, please contact your Dealer or our Customer Care Centre at:

Telephone #: (905) 624-5505

Fax #: (905) 238-2360

Web: www.panasonic.ca

For product repairs, please contact one of the following:

- Your Dealer who will inform you of an authorized Servicentre nearest you.
- Our Customer Care Centre at (905) 624-5505 or www.panasonic.ca

RÉPARATION SOUS GARANTIE

Pour de l'aide sur le fonctionnement de l'appareil ou pour toute demande d'information, veuillez contacter votre détaillant ou notre service à la clientèle au :

N° de téléphone : (905) 624-5505 N° de télécopieur : (905) 238-2360 Site Internet : www.panasonic.ca

Pour la réparation des appareils, veuillez consulter :

- votre détaillant, lequel pourra vous renseigner sur le centre de service agréé le plus près de votre domicile ;
- notre service à la clientèle au (905) 624-5505 ou www.panasonic.ca;
- un de nos centres de service indiqué sur la page de garantie.

Quando necesita servicio

Si su aspiradora Panasonic necesita servicio, busque el Centro de Servicio Panasonic o un Centro de Servicio PASC autorizado más cercano bajo "Servicio de Electrodomésticos" en las páginas amarillas de la guía de teléfonos o llame gratis al 1-800-211-PANA (7262) para encontrar un centro de servicio conveniente. No mande el producto a las Executive o Regional Sales Offices. No están equipadas para arreglar estos productos.

Si manda el producto

Empaquete con cuidado en el cartón original si posible y mándelo prepagado y con seguro suficiente. Ponga una carta con sellos en la que describe su problema con el producto en el exterior del cartón. No mande el producto a las Executive o Regional Sales Offices. No están equipadas para arreglar estos productos.

PANAMEX COMPANY
DIVISION OF PANASONIC CORPORATION OF NORTH AMERICA

One Panasonic Way
Secaucus, New Jersey 07094
World Wide Web Address
<http://www.panasonic.com>

AÇ01ZDDPZ000
C01ZDDP20000

Printed in China
Imprimé en Chine
Impreso en China