

# Panasonic®

**VACUUM CLEANER (HOUSEHOLD)**

*Aspirateur (Domestique)*

*Aspiradora (Domestico)*

**Model No. MC-UL915**

**Operating Instructions**

*Manuel d'utilisation*

*Instrucciones de operación*

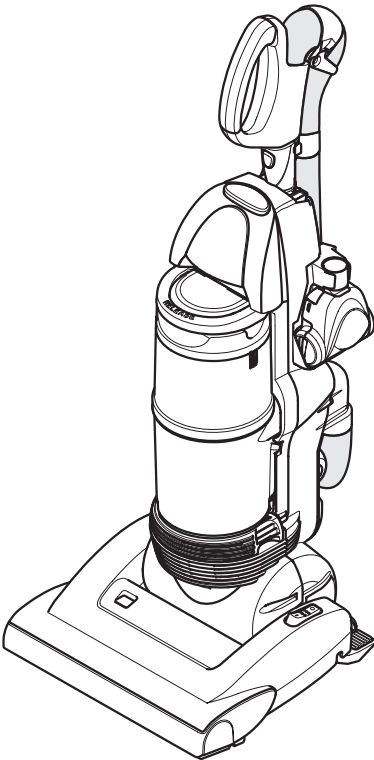

**Before operating your vacuum cleaner,  
please read these instructions completely.**

*Avant d'utiliser l'appareil, il est recommandé  
de lire attentivement ce manuel.*

*Antes de usar su aspiradora, lea  
completamente estas instrucciones por favor.*

# TABLE OF CONTENTS

CONSUMER INFORMATION .....	5
IMPORTANT SAFETY INSTRUCTIONS .....	8-9
PARTS IDENTIFICATION .....	14-15
FEATURE CHART .....	15
ASSEMBLY .....	16
FEATURES .....	18
Overload Protector .....	18
Automatic Self Adjusting Nozzle .....	18
Dirt Sensor .....	20
Carpet/Bare Floor Selector .....	20
Edge Cleaning .....	20
Adjustable Handle Release .....	22
Motor Protector .....	22
Thermal Protector .....	24
TO OPERATE VACUUM CLEANER .....	26
Power Cord .....	26
Cord Hook .....	26
Adjustable Handle .....	28
Locking Notch .....	28
ON/OFF Switch .....	28
Body Release .....	30
Carpet/Bare Floor Selector .....	30
Using Tools .....	32
Tools .....	34
ROUTINE CARE OF VACUUM CLEANER .....	36
Emptying Dust Bin .....	36
Cleaning Dirt Sensor Optics .....	40
Dust Bin Cleaning .....	42
Cleaning Pre-Filter .....	46
Replacing HEPA Exhaust Filter .....	48
Primary Filter Cleaning .....	50
Removing and Installing Lower Plate .....	52
Replacing Belt .....	54
Replacing Headlight Bulb .....	56
Cleaning Exterior and Tools .....	58
Cleaning Agitator .....	58
Removing Clogs .....	60
BEFORE REQUESTING SERVICE .....	64
WARRANTY .....	67, 68
WHAT TO DO WHEN SERVICE IS NEEDED .....	72

# CONSUMER INFORMATION

Please read **IMPORTANT SAFETY INSTRUCTIONS** on pages 8-9 before use. Read and understand all instructions.

## TO OUR VALUED CUSTOMER

We are very pleased to welcome you to the Panasonic family of products. Thank you for purchasing this product. Our intent is that you become one of our many satisfied customers.

**Proper assembly and safe use of your vacuum cleaner are your responsibilities. Your vacuum cleaner is intended only for household use. The vacuum cleaner should be stored in a dry, indoor area. Read the Operating Instructions carefully for important use and safety information.**

**Special care is required when vacuuming certain types of carpet or floor covering. Always check the carpet or floor covering manufacturer's recommended cleaning instructions before vacuuming.**

## PLEASE PAY CLOSE ATTENTION TO ALL WARNING AND CAUTION STATEMENTS.



**WARNING** statements are designed to alert you to the possibility of personal injury, loss of human life, and/or damage to the vacuum cleaner and/or personal property if the instructions given are not followed.



**CAUTION** statements are designed to alert you to the possibility of damage to the vacuum cleaner and/or personal property if the instructions given are not followed.



### TO AVOID ELECTRICAL SHOCK

Never vacuum damp or wet surfaces or liquids.  
DO NOT store vacuum cleaner outdoors.  
Replace worn or frayed power cord immediately.  
Unplug from outlet when not in use and before servicing.

### TO AVOID ACCIDENTS

Except for hand-held cleaners, keep vacuum cleaner on floor - not chairs, tables, steps, stairs, etc.  
Store vacuum cleaner promptly after each use to prevent accidents such as tripping over power cord or vacuum cleaner.  
Use vacuum cleaner and accessories only in a manner intended by the manufacturer.  
The use of an extension cord is not recommended.

# IMPORTANT SAFETY INSTRUCTIONS

When using your vacuum cleaner, basic precautions should always be followed, including the following:

Read all instructions in this manual before assembling or using your vacuum cleaner.

## WARNING

To reduce the risk of fire, electrical shock, injury:

1. **Use** your vacuum cleaner only as described in this manual. Use only with Panasonic recommended attachments.
2. **Disconnect** electrical supply before servicing or cleaning out the brush area. Failure to do so could result in the brush unexpectedly starting, causing personal injury from moving parts.
3. **Do not** leave vacuum cleaner when plugged in. Unplug from outlet when not in use and before servicing.
4. **To reduce** the risk of electrical shock - Do not use outdoors or on wet surfaces.
5. **Do not** allow to be used as a toy. Close attention is necessary when used by or near children.
6. **Do not** use with a damaged cord or plug. If vacuum cleaner is not working as it should, has been dropped, damaged, left outdoors, or dropped in water, return it to a Panasonic Service Center.
7. **Do not** pull or carry by cord, use cord as a handle, close a door on cord, or pull cord around sharp edges or corners. Do not run vacuum cleaner over cord. Keep cord away from heated surfaces.
8. **Do not** unplug by pulling on cord. To unplug, grasp the plug, not the cord.
9. **Do not** handle plug or vacuum cleaner with wet hands.
10. **Do not** put any objects into openings.
11. **Do not** use with any opening blocked; keep free of dust, lint, hair, and anything that may reduce air flow.
12. **Keep** hair, loose clothing, fingers, and all parts of body away from openings and moving parts.
13. **Turn off** all controls before unplugging.
14. **Use** extra care when cleaning on stairs.
15. **Do not** put on chairs, tables, etc. Keep on floor.
16. **Do not** use vacuum cleaner to pick up flammable or combustible liquids (gasoline, cleaning fluid, perfumes, etc.), or use in areas where they may be present. The fumes from these substances can create a fire hazard or explosion.
17. **Do not** pick up anything that is burning or smoking, such as cigarettes, matches, or hot ashes.
18. **Do not** use vacuum cleaner without dust bin and/or filters in place.

19. **Always** clean the dust bin after vacuuming carpet cleaners or freshner powders, and fine dust. The products clog the filters, reduce airflow and can cause damage to the vacuum cleaner. Failure to clean the dust bin could cause permanent damage to the vacuum cleaner.
20. **Do not** use the vacuum cleaner to pick up sharp hard objects, small toys, pins, paper clips, etc. They may damage the vacuum cleaner or dust bin.
21. **Unplug** before connecting Air Turbine.
22. **You are** responsible for making sure that your vacuum cleaner is not used by anyone unable to operate it properly.

## **SAVE THESE INSTRUCTIONS**

### **THIS VACUUM CLEANER IS INTENDED FOR HOUSEHOLD USE ONLY**

**NOTE:** Before you plug in your Panasonic vacuum cleaner, make sure that the voltage indicated on the rating plate located at the back of the vacuum cleaner is the same as your local electrical supply.

# PARTS IDENTIFICATION

## Nomenclature

## Identificación de piezas

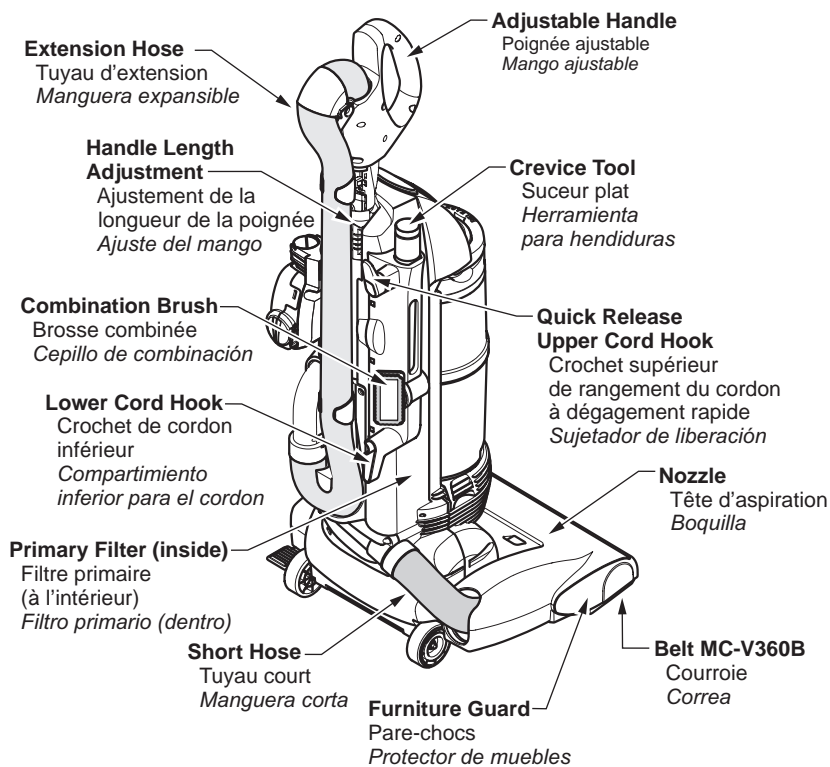

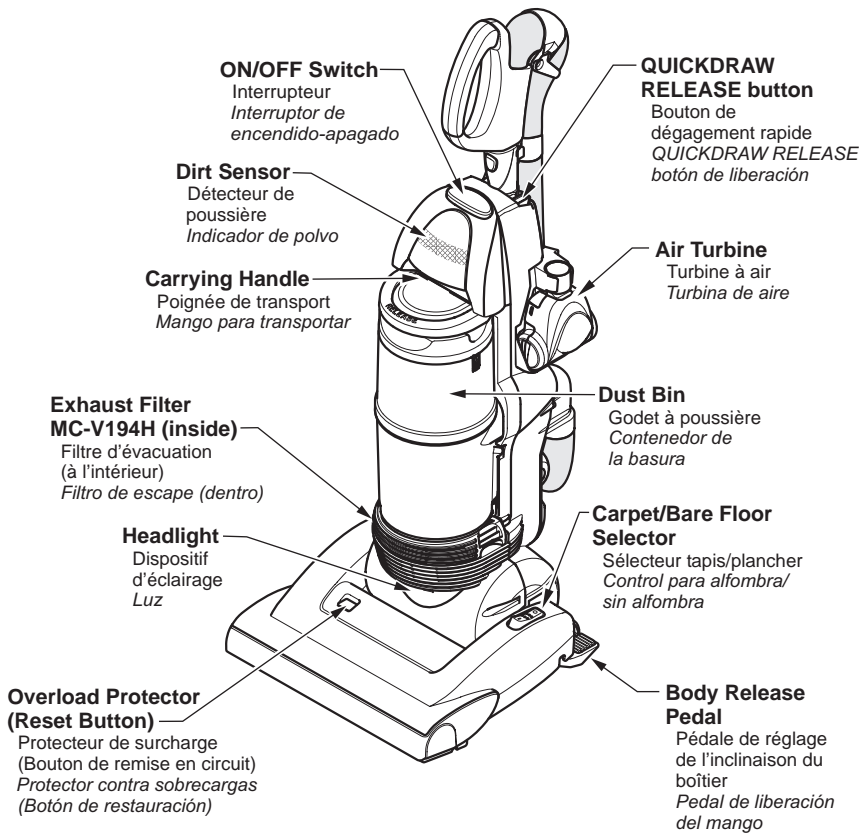

## FEATURE CHART

Power	Dirt Sensor	Headlight	Cord Length	Bare Floor
120V AC (60Hz)	Yes	Yes	35 Ft	Yes

### Tableau des caractéristiques

Alimentation	Décteur de poussière	Dispositif d'éclairage	Longueur du cordon	Position plancher
120 V c.a. (60 Hz)	Oui	Oui	10,7m (35 pi)	Oui

### Diagrama de características

Voltaje	Sensor de basura	Luz	Extensión de cordón	Uso sin alfombra
120 V c.a. (60 Hz)	Si	Si	10.7m (35 pi)	Si

## ASSEMBLY

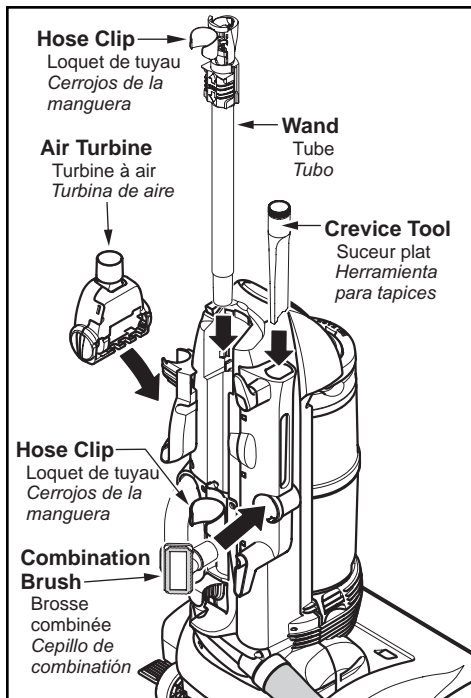

### CAUTION

**DO NOT** plug in until assembly is complete.

- Insert wand into vacuum cleaner until it locks in place.
- Insert crevice tool, dusting brush, and Air Turbine into storage locations on the vacuum cleaner.

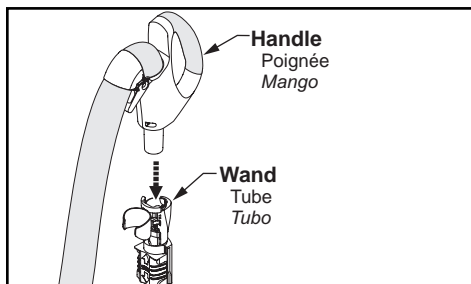

- Insert handle into wand.
- Insert hose into clips on the wand and the back of the vacuum cleaner.

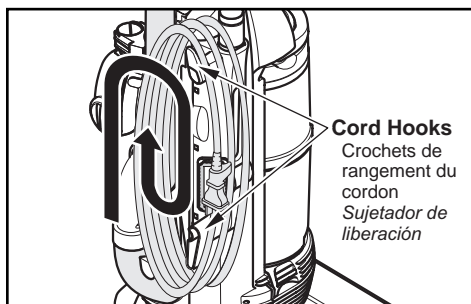

- Wrap power cord clockwise around upper and lower cord hooks as shown.



# FEATURES

## Overload Protection

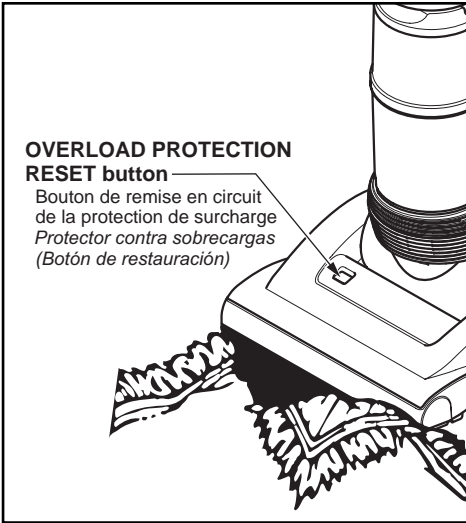

- The **OVERLOAD PROTECTION RESET** button stops the nozzle motor when the brush jams to prevent belt breakage.

**NOTE:** The vacuum cleaner motor will continue to run.

### TO CORRECT PROBLEM:

- Unplug electrical cord.
- Check nozzle areas for excessive lint buildup or jamming.
- Clean jammed area.

### TO RESET:

- Press reset button on top of the nozzle. Plug in and turn on vacuum cleaner.

## Automatic Self Adjusting Nozzle

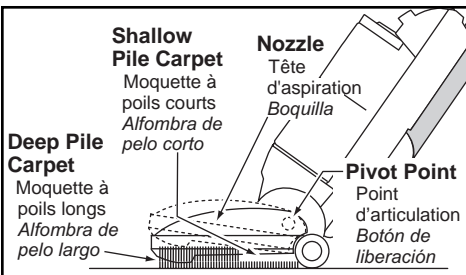

- The nozzle of your Panasonic vacuum cleaner automatically adjusts to any carpet pile height.
- Feature allows nozzle to float evenly over carpet pile surfaces.
- No manual adjustments required.

## Dirt Sensor

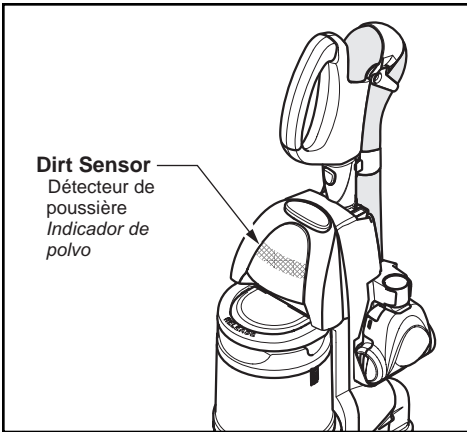

- The electronic dirt sensor is a feature which will detect particles as they pass through the vacuum cleaner.
- The dirt sensor indicator is located on the front of the vacuum cleaner as illustrated.
- When there is little or no dirt present the dirt sensor is green.
- With normal or heavy dirt concentration the dirt sensor is red.

## Carpet/Bare Floor Selector

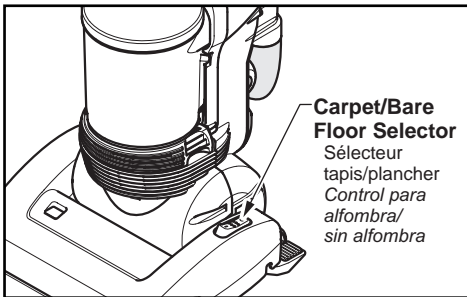

- Selector should be placed in BARE FLOOR (TOOLS) position when using vacuum cleaner on bare floors and when using tools. The agitator does not rotate in the BARE FLOOR (TOOLS) position.
- Selector should be placed in CARPET position when using vacuum cleaner on carpeted floors.

## Edge Cleaning

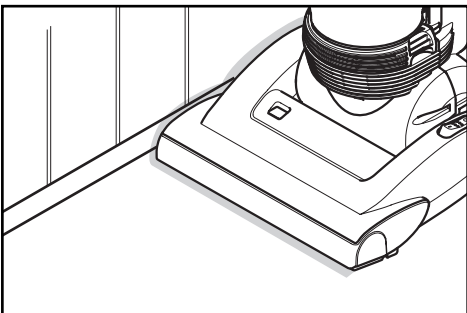

- Edge cleaning feature enables improved cleaning of carpets near walls and furniture.

## Adjustable Handle Release

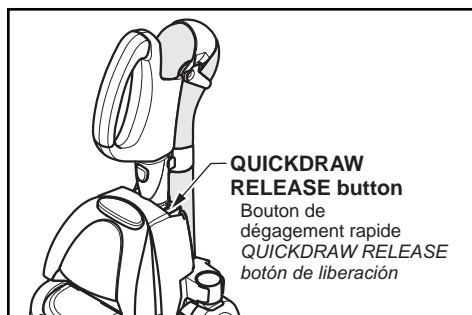

- Remove the handle by pushing the **QUICKDRAW RELEASE** button.
- Lift adjustable handle assembly out of the vacuum cleaner.
- With the handle free from the vacuum cleaner it now can be used as an extension wand. Length can be changed when being used as a wand.
- Add attachments to suit your cleaning needs.

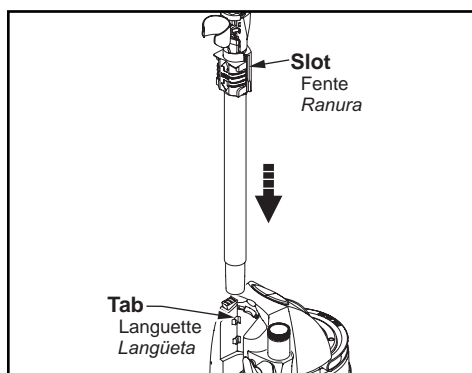

- Place adjustable handle securely back into the vacuum cleaner by aligning slots on handle assembly with tabs on body as shown.

## Motor Protector

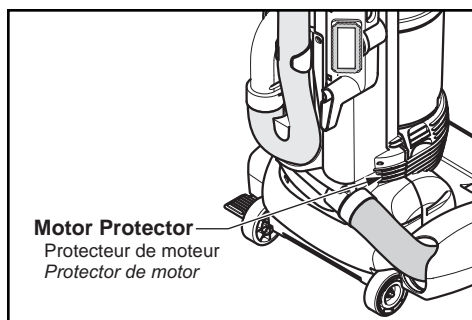

- Automatically opens to provide cooling air to the motor when a clog occurs or when dust bin needs emptying.
- Motor protector may open when using tools.
- If motor protector opens, the vacuum cleaner will make a slightly different sound.

**Note:** Do not block motor protector.

## Thermal Protector

- This vacuum cleaner has a thermal protector which automatically trips to protect the vacuum cleaner from overheating.
- If a clog prevents the normal flow of air to the motor, the thermal protector turns the motor off automatically. This allows the motor to cool in order to prevent possible damage to the vacuum cleaner.

### TO CORRECT PROBLEM:

- Turn the vacuum cleaner off and unplug the power cord from the outlet to allow the vacuum cleaner to cool and the thermal protector to reset.
- Check for and remove clogs, if necessary. Also check and replace any clogged filters and empty dust bin if necessary.
- Wait approximately fifty (50) minutes and plug the vacuum cleaner in and turn back on to see if the motor protector has reset.

## TO OPERATE VACUUM CLEANER

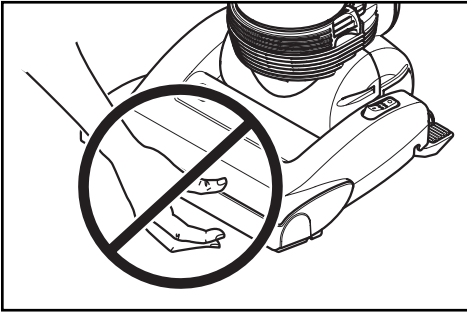

### **⚠ CAUTION**

Moving parts! To reduce the risk of personal injury, **DO NOT** touch the agitator when vacuum cleaner is on. Contacting the agitator while it is rotating can cut, bruise or cause other injuries. Always unplug from electrical outlet before servicing. Use caution when operating near children.

## Power Cord

**Note:** To reduce the risk of electrical shock, this vacuum cleaner has a polarized plug, one blade is wider than the other. This plug will fit in a polarized outlet only one way. If the plug does not fit fully in the outlet, reverse the plug. If it still does not fit, contact a qualified electrician to install the proper outlet. **DO NOT CHANGE THE PLUG IN ANY WAY.** Only use outlets near the floor.

## Cord Hook

### **Cord Hook**

Crochet de rangement du cordon  
Sujetador de liberación

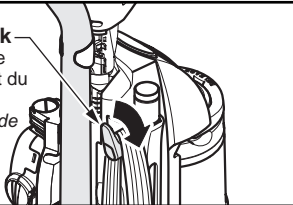

- Detach plug head from power cord.
- Rotate cord hook down to release cord.
- Return the cord hook to the upright position before attempting to rewind the cord.

## Adjustable Handle

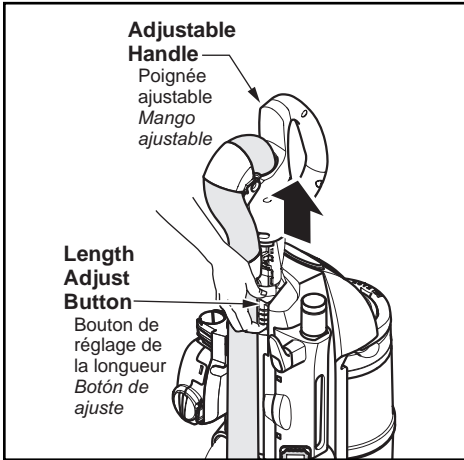

- Press the handle **LENGTH ADJUST** button located on the back of the vacuum cleaner.
- Raise or lower the adjustable handle to the desired operating position.

### CAUTION

**DO NOT** carry the vacuum cleaner by the adjustable handle. Use **ONLY** the carrying handle located on the front of the vacuum cleaner.

## Locking Notch

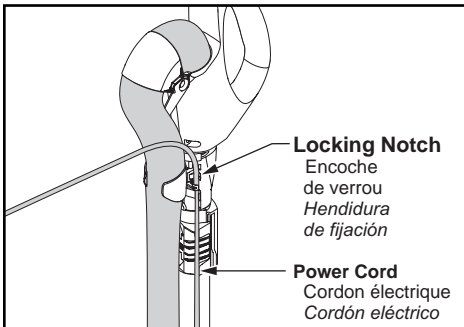

- Make sure the power cord is placed into the locking notch as shown.

**Note:** This helps keep the power cord out from under the vacuum cleaner agitator.

## ON / OFF Switch

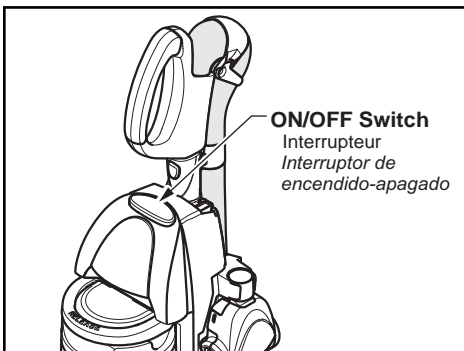

- Plug the power cord into an outlet near the floor.
- Press the switch to turn the vacuum cleaner on.
- When finished vacuuming, press the switch again to turn the vacuum cleaner off.
- Unplug the cord from the outlet when not in use.

## Body Release

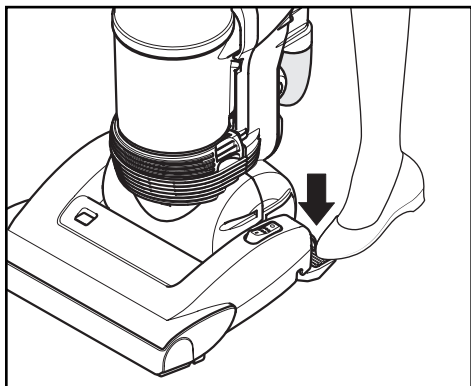

- Your vacuum cleaner is equipped with three (3) position body release;
  - Upright position (locked)
  - Middle position (normal use)
  - Low position (under furniture)
- Release the body by pressing down on the body release pedal with your foot and pulling back and down on the handle with your hand.
- Move the vacuum cleaner to upright position for storage and tool use.

## CAUTION

**DO NOT** press the handle quick release button when the vacuum cleaner is in use.

## Carpet/Bare Floor Selector

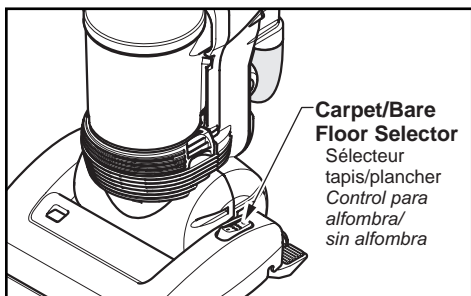

- Selector should be placed in BARE FLOOR (TOOLS) position when using vacuum cleaner on bare floors and when using tools. The agitator does not rotate in the BARE FLOOR (TOOLS) position.
- Selector should be placed in CARPET position when using vacuum cleaner on carpeted floors.

## Using Tools



- Press the handle quick release button on the wand to remove the handle to use tools on the handle.

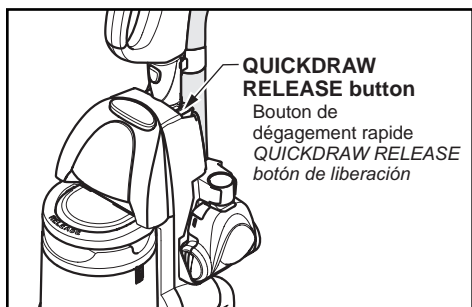

- Press the QUICKDRAW RELEASE button to remove the extension wand from the vacuum cleaner to use tools on the extension wand.
- Add attachments to suit your cleaning needs. (see TOOLS for suggested attachment usage)

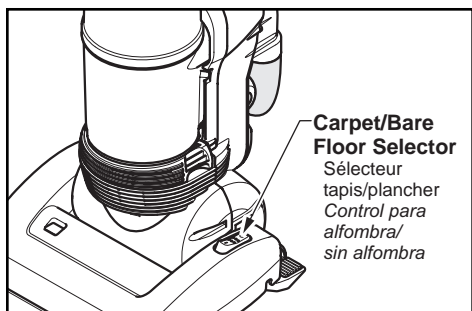

- Selector should be placed in BARE FLOOR (TOOLS) position when using vacuum cleaner on bare floors and when using tools.

### CAUTION

When using attachments, place one hand on the vacuum cleaner to prevent tipping the vacuum cleaner over.



## Tools



- The Crevice Tool may be used on the following items:
  - Furniture
  - Cushions
  - Drapes
  - Stairs
  - Walls

### Dusting Brush

Brosse à épousseter  
Cepillo para sacudir



Fabric Brush  
Brosse à tissu  
Cepillo para telas

- The Combination Brush may be used on the following items:
  - Furniture
  - Drapes
  - Stairs
  - Walls



- The Floor Brush may be used on the following items:
  - Stairs
  - Floors

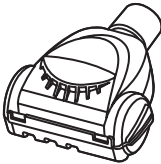

- The Air Turbine may be used on the following items:
  - Furniture
  - Stairs
- Operating instructions for the Air Turbine are included with the product.

**Note:** Always clean tools before using.

## ROUTINE CARE OF VACUUM CLEANER

Performing the following tasks will keep your new Panasonic vacuum cleaner operating at peak performance levels and will ensure these high levels for years to come. Check the **BEFORE REQUESTING SERVICE** section in this manual for recommendations on performing some of these tasks to help solve various problems that may occur.

### **WARNING** Electrical Shock or Personal Injury Hazard

Disconnect the electrical supply before servicing or cleaning the vacuum cleaner. Failure to do so could result in electrical shock or personal injury from vacuum cleaner suddenly starting.

### Emptying Dust Bin

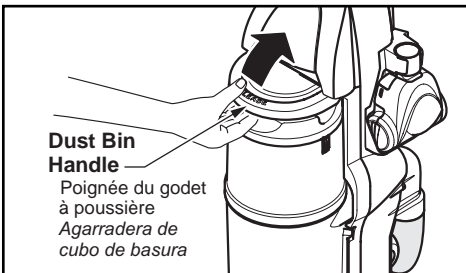

➤ Always empty the dust bin when dirt level reaches the “MAX” line.

➤ Grasp the handle on the top of the dust bin. Lift up and out to remove dust bin from vacuum cleaner.

➤ Remove any clogs that might be located in the pre-filter. (See “Cleaning Pre-Filter”)

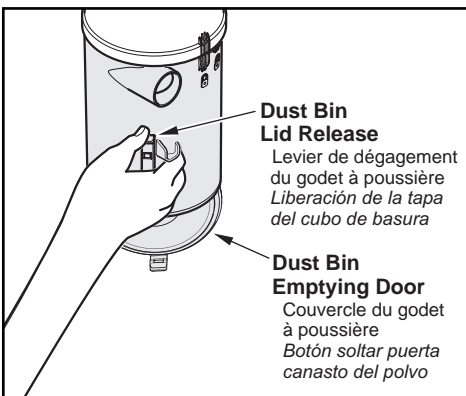

### **CAUTION**

Be sure to hold the dust bin over a proper trash container prior to releasing the door of the dust bin.

➤ Press dust bin lid release and the dust bin will open and the debris will fall out.

➤ Shake the dust bin to release any debris that might hang in the pre-filter

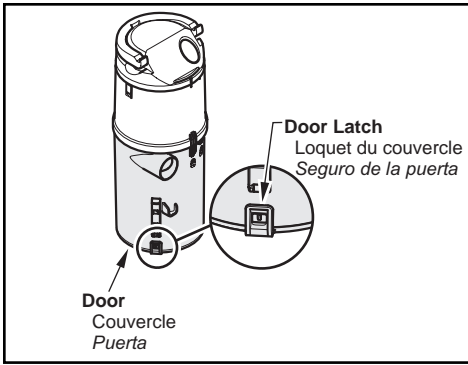

## TO REPLACE DUST BIN

- After the dust bin is empty of debris, firmly close the door. Make sure you hear a "click" sound to indicate that the door is fully latched.

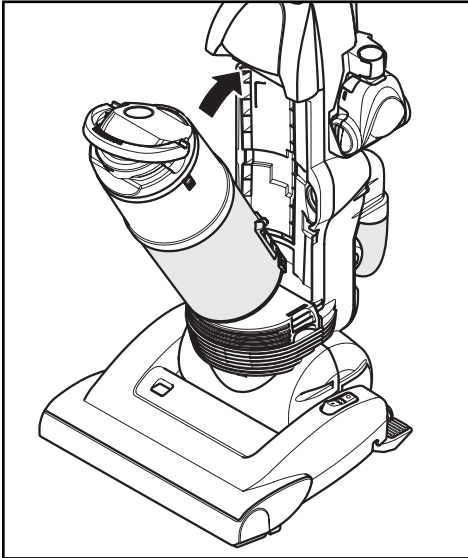

- Place dust bin back into vacuum cleaner by inserting the bottom first and tilting back.
- Push forward and lower dust bin handle to lock dust bin in place.

## Cleaning Dirt Sensor Optics

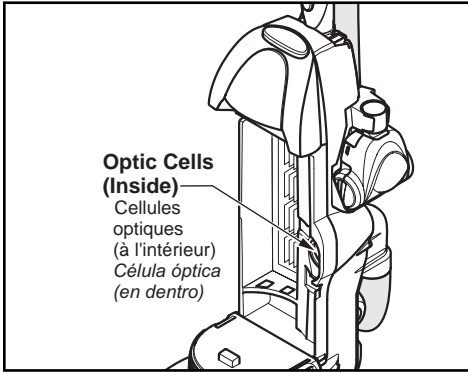

- The dirt sensor optics consist of two optic cells located inside the suction inlet. Occasionally, it may become necessary to clean the two optic cells to assure maximum performance.
  
- **Clean optic cells:**
  - When dirt or dust adheres to the optic cells.
  - Whenever the dust bin is cleaned.
  
- To clean the dirt sensor optics, remove dust bin from vacuum cleaner.
  
- Wipe the optic cells with a soft, dry cloth.
  
- Never use cleaners or liquids as they can help speed the recoating of the optic cells and make it necessary to clean them much sooner than normal.

## Dust Bin Cleaning

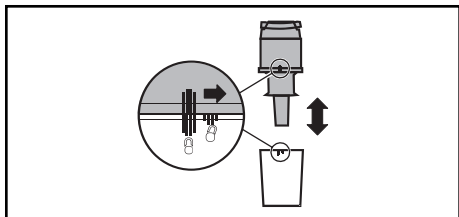

### To Disassemble Dust Bin:

- Remove dust bin from vacuum cleaner (See **EMPTYING DUST BIN**) and empty contents.

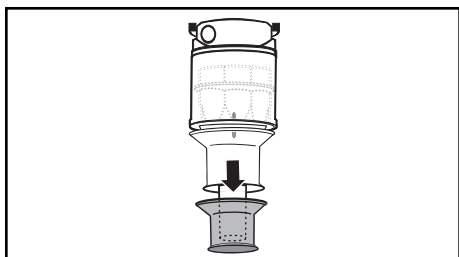

- Remove pre-filter by pulling downward as shown. See **PRE-FILTER CLEANING**

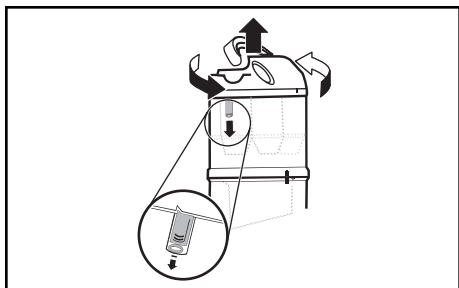

- Rotate upper dust bin to unlock, then lift off.
- Press the lid release button downward and twist lid to remove from dust bin.

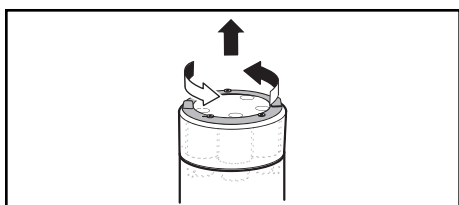

- Rotate fastener ring to unlock, and lift off.

- Remove upper portion of dust bin from air guide.

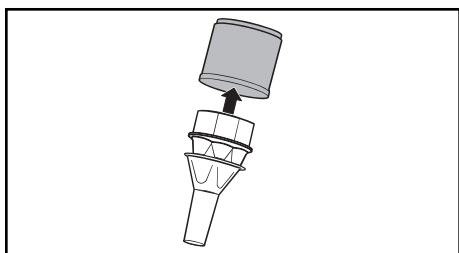

- Rinse with cold water only, **DO NOT** use detergent or soap. Allow parts to dry 24 hours before putting back into vacuum cleaner.

- **DO NOT** wash in the dishwasher.

- **DO NOT** install parts if still damp.

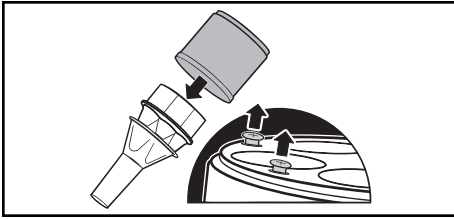

To assemble dust bin:

- Reinstall upper portion of dust bin onto air guide so that the locking screws pass through the holes in the upper portion.

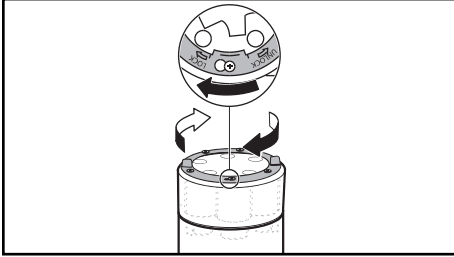

- Using alignment marks on the fastener ring and dust bin, place fastener ring onto dust bin and rotate to lock in place.

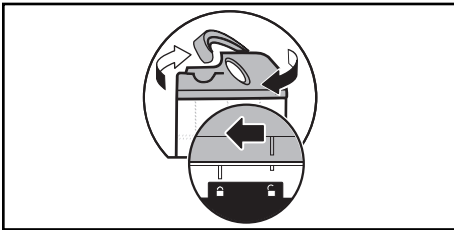

- Place the dust bin lid on the upper portion of the dust bin using alignment slots, and rotate until the lid locks in place.

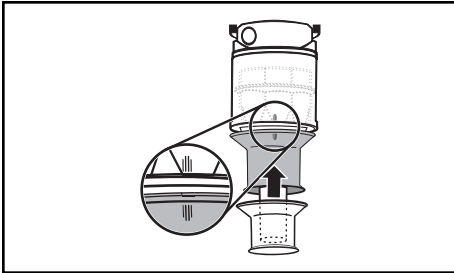

- Reinstall pre-filter by using the alignment ribs on the pre-filter to align with the ribs on the upper portion of the dust bin.

- Press into place. A noticeable “click” should be heard.

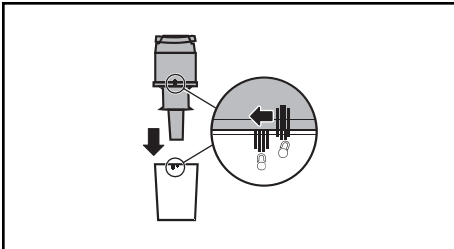

- Reinstall lower portion of the dust bin by aligning ribs on the upper portion with the UNLOCK ribs on the lower portion.

- Rotate until ribs from the upper portion of the dust bin align with the LOCK ribs.

**NOTE:** If lower portion of dust bin does not fit properly check pre-filter installation.

## Cleaning Pre-Filter

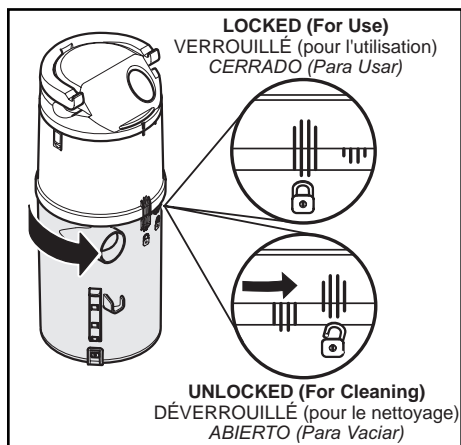

- Empty dust bin.
- Rotate dust bin lid assembly counter-clockwise (as indicated on the lid), and lift off.
- Clean pre-filter by gently tapping over a trash container.
- Rinse with water only as needed, do not use any detergent or soap.

**DO NOT** wash in the dishwasher.  
**DO NOT** install damp.

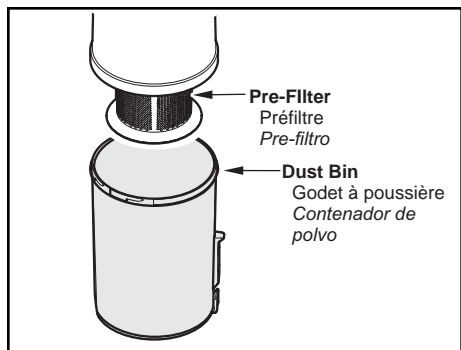

- Allow pre-filter to dry for 24 hours before placing back into vacuum cleaner.

### To Reinstall:

- Replace the lower portion of the dust bin by aligning marks as shown, **UNLOCKED (For Cleaning)**.
- Rotate while pressing downward until marks align as shown; **LOCKED (For Use)**.
- Reinstall the dust bin.

## Replacing HEPA Exhaust Filter

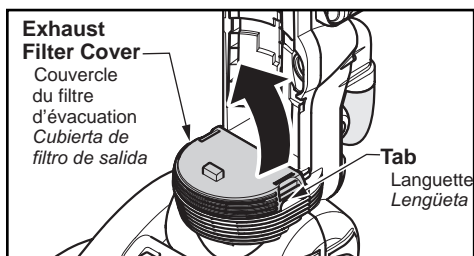

- The HEPA exhaust filter removes dirt from exhaust air.
- Check filter after emptying dust bin. Replace when dirty.\*
- To remove, lift at tab.

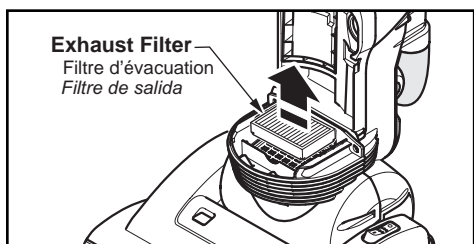

- Grasp the exhaust filter and pull out to remove.

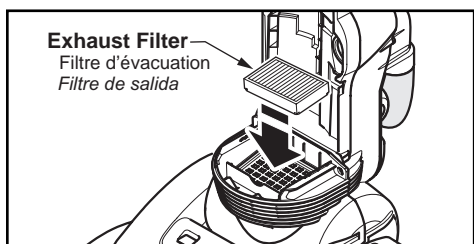

- Ensure foam edge of the filter is facing towards the vacuum cleaner when placing filter into filter compartment.

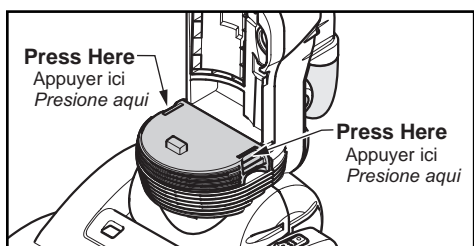

- Reinstall exhaust filter cover by placing the cover on the body and snapping into place as shown.
- \* Filter cannot be cleaned and should be replaced at least once each year.  
Part Number: MC-V194H



## Primary Filter Cleaning

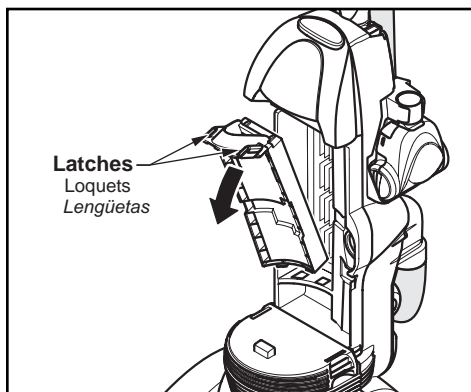

It is recommended to clean filter with cold water at least every three (3) months.

Check the primary filter frequently and clean when dirty.

➤ Remove the cover by pressing the latches located on each side.

➤ Lift cover off of vacuum cleaner.

➤ Remove the primary filter from the filter cover.

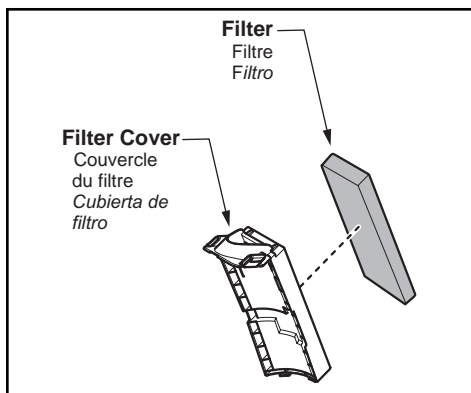

➤ Wash with cold water only, DO NOT use detergent or soap.

➤ Once the filter is washed clean, squeeze by hand and allow to air dry.

➤ Allow filter to dry 24 hours before putting back into vacuum cleaner.

**NOTE:** When the cleaning of the filter no longer restores vacuum cleaner suction to full power, replace the filter.

**DO NOT** operate without primary filter installed.

**DO NOT** wash in the dishwasher.

**DO NOT** install damp.

➤ Reinstall the filter into the filter cover.

➤ Reinstall the filter cover by snapping into place on the the vacuum cleaner. A noticeable “click” should be heard.



## WARNING

Electrical Shock or Personal Injury Hazard

Disconnect the electrical supply before servicing or cleaning the vacuum cleaner. Failure to do so could result in electrical shock or personal injury from vacuum cleaner suddenly starting.

### Removing and Installing Lower Plate

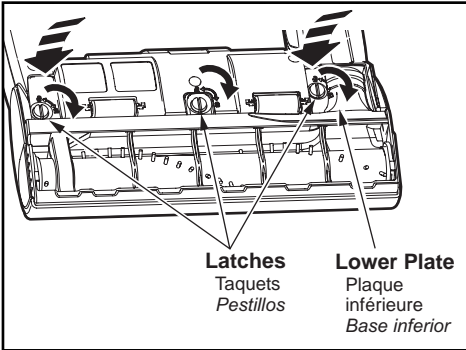
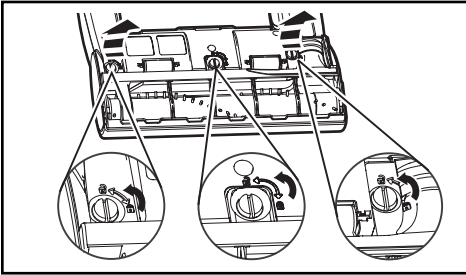

- **Before servicing any parts, disconnect vacuum cleaner from electrical outlet.**
- **Always place paper under nozzle whenever lower plate is removed to protect floor.**
- **Place body in upright position and turn vacuum cleaner over to expose lower plate.**
- **Release lower plate by rotating the lower plate latches to the UNLOCK position.**
- **Remove lower plate and remove any residue that may exist in belt area.**
- **Reinstall lower plate by hooking front end of lower plate into slots on front of nozzle.**
- **Press lower plate onto nozzle and secure by rotating the lower plate latches to the LOCK position.**

## Replacing Belt

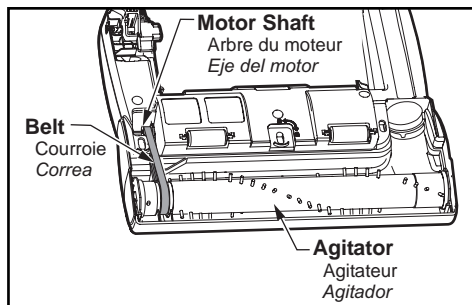

- Replace belt whenever a burning rubber smell caused by excessive slippage occurs.
- Remove lower plate. See “Removing and Installing Lower Plate”

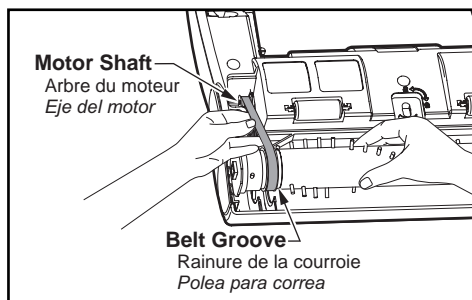

- Remove agitator by carefully lifting out.
- Remove worn or broken belt.
- Clean agitator and the end caps.

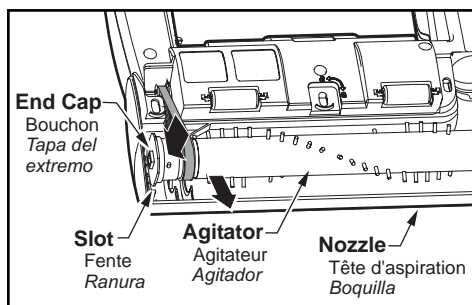

- Loop new belt around motor shaft and agitator belt groove; see illustration for correct belt routing.
- Reinstall agitator back into nozzle housing grooves.

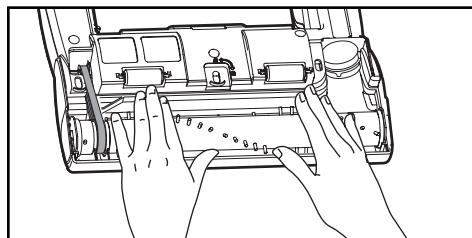

- After reinstalling the agitator, turn it by hand to make sure that belt is not twisted or pinched and that all rotating parts turn freely.
- Reinstall lower plate. Ensure tabs are locked into slots.

## Replacing Headlight Bulb

### Flat Screwdriver

Tournevis à lame plate  
Desarmador plano

### Headlight Lens

Lentille de la lampe  
Lente de la luz

Slots  
Fentes  
Ranuras

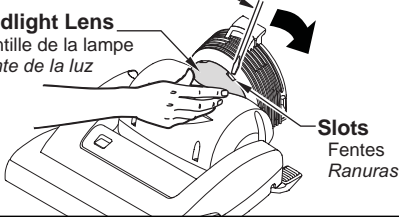

- Disconnect power cord from electrical outlet. Lower body to lay the vacuum cleaner flat.
- Gently pry out light lens at slots by inserting screwdriver into slot, pushing down on the lens and rotating the screwdriver handle toward vacuum cleaner.

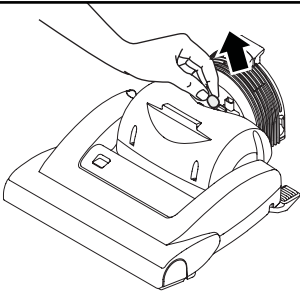

- Remove the light bulb by pulling straight out.



### CAUTION

Do not use a bulb rated over 9W (13V). During extended use, heat from the bulb could overheat surrounding plastic parts.

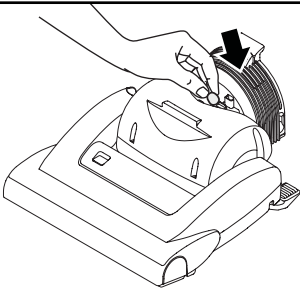

- To replace the light bulb carefully insert securely into slot. Replace lens cover.

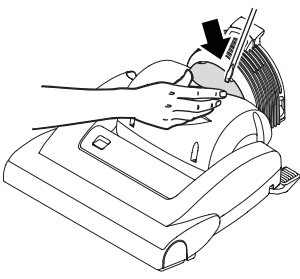

- Replace lens cover by inserting bottom tab of lens into slot then applying pressure to top tabs.
- A “popping” sound indicates lens is snapped properly in place.

## Cleaning Exterior and Tools

- Unplug cord from wall outlet.
- Clean exterior using a clean, soft cloth that has been dipped in a solution of mild liquid detergent and water and wrung dry.
- DO NOT drip water on the vacuum cleaner and wipe dry after cleaning.
- DO NOT clean tools in dishwasher or clothes washer.
- Wash tools in warm soapy water, rinse and air dry.
- DO NOT use tools if they are wet.

## Cleaning Agitator

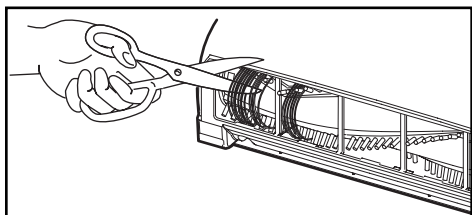

- Clean agitator after every five uses and every time the belt is replaced.
- Remove lower plate. See: “Removing and Installing Lower Plate”
- Cut off any hair, thread, string, carpet pile, and lint entangled around agitator with a pair of scissors.
- Remove agitator. See: “Replacing Belt”
- Remove any string or debris located on the end caps, washers or agitator shaft.
- Reinstall agitator and lower plate. See: “Removing and Installing Lower Plate”

## Removing Clogs

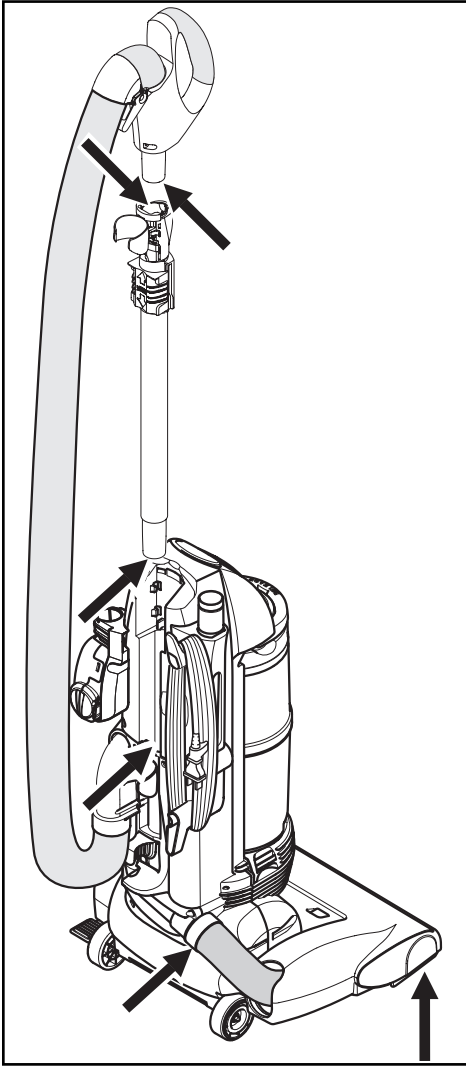

If the vacuum cleaner does not seem to have adequate suction, first check if the dust bin is full or if a filter is clogged.

- Check the handle and extension wand area.
- Remove handle by pressing handle quick release button.
- Visually inspect the hose and the base area into which the hose is connected.
- Remove any visible clog.
- Plug in the vacuum cleaner and turn it on.
- Stretch the hose to maximum length and then allow the hose to return to its storage length.
- Turn off and unplug the vacuum cleaner.
- Remove lower plate. See: “Removing and Installing Lower Plate”
- Inspect inlet of nozzle hose and clear any obstructions.
- Remove dust bin and check for clogs.

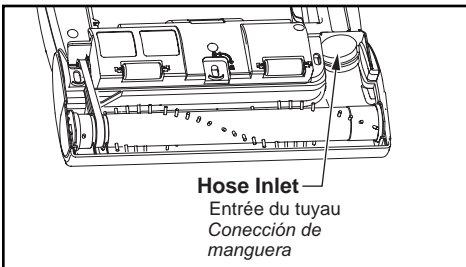

- If the dust bin and filter areas and the hose areas are free of clogs, check the nozzle area.
- Return the vacuum cleaner to the upright position before plugging into an electrical outlet.

## Dégagement des obstructions

Si l'aspirateur semble ne pas avoir assez de puissance d'aspiration, voir d'abord si le godet à poussière est plein ou si le filtre est obstrué.

- Vérifier la poignée et le tuyau d'extension.
- Retirer la poignée en appuyant sur le bouton de dégagement.
- Inspecter visuellement le tuyau ainsi que les alentours de la base dans laquelle le tuyau est connecté.
- Dégager les obstructions.
- Brancher l'aspirateur et le mettre en marche.
- Étirer le tuyau à sa longueur maximale, puis le laisser reprendre sa forme de rangement.
- Arrêter l'aspirateur et débrancher.
- Retirer la plaque inférieure. Voir: "Enlèvement et installation de la plaque inférieure"
- Vérifier l'entrée du tuyau court et éliminer toute obstruction.
- Retirer le godet à poussière et vérifier l'orifice d'entrée du godet à poussière pour toute obstruction.
- Si le godet, le filtre et le tuyau sont libres d'obstructions, vérifier la tête d'aspiration.
- Retourner l'aspirateur à sa position verticale avant de brancher à une prise d'alimentation.

## Quitando los residuos de basura en los conductos

*Si considera que la aspiradora no aspira bien asegúrese primero de que la contenedor de polvo no esté lleno y de que el filtro no esté atascado.*

- *Si las zonas del filtro y la contenedor de polvo no están atascadas, examine la zona de la manguera.*
- *Remueva el mango presionando el botón de liberación rápida del mango.*
- *Examine visualmente la zona de la base donde se inserta la manguera.*
- *Retire cualquier material bloqueante.*
- *Enchufe la aspiradora y échela a andar.*
- *Estire la manguera a la longitud máxima y retórnela a la longitud de almacenaje.*
- *Apague la unidad y desconéctela.*
- *Quite la base inferior. Vea: "Remover y reinstalar la base inferior"*
- *Revise el extremo de la manguera y quite los obstáculos.*
- *Remueva el contenedor de polvo y chequee la puerta por obstáculos.*
- *Si el contenedor de polvo y áreas de filtrado y áreas de la manguera están libres de obstáculos, revise el área de la boquilla.*
- *Retorne la aspiradora a la posición vertical antes de enchufarla en un tomacorriente.*

**Dust Bin Lid**

Couvercle du  
godet à poussière  
Cubierta de contenedor  
de polvo

**Release Button**

Bouton de  
dégagement  
Botón de liberador

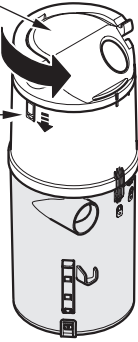

**TO REMOVE CLOG FROM DUST BIN**

- Press the release button on the side of the dust bin.
- While pressing the release button rotate the top of the dust bin counter-clockwise.

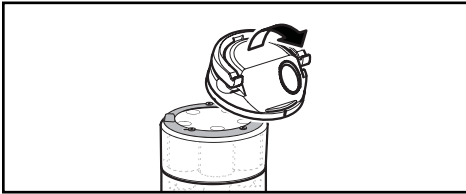

- Lift off dust bin lid.
- Remove any clogs or debris under dust bin lid.

**To Replace:**

- Align the slot on the dust bin lid with the short slot on the dust bin.
- Rotate dust bin lid clockwise until it locks in place. The slot on the dust bin lid should align with the long slot on the dust bin.



## BEFORE REQUESTING SERVICE



### **WARNING** Electrical Shock or Personal Injury Hazard

Disconnect the electrical supply before servicing or cleaning the vacuum cleaner. Failure to do so could result in electrical shock or personal injury from vacuum cleaner suddenly starting.

Review this chart to find do-it-yourself solutions for minor performance problems. Any service needed, other than those described in these Operating Instructions, should be performed by an authorized service representative.

PROBLEM	POSSIBLE CAUSE	POSSIBLE SOLUTION
Vacuum Cleaner won't run.	<ol style="list-style-type: none"> <li>1. Unplugged at wall outlet.</li> <li>2. Tripped circuit breaker/blown fuse at household service panel.</li> <li>3. Thermal protector tripped.</li> <li>4. Defective wall outlet.</li> </ol>	<ol style="list-style-type: none"> <li>1. Plug in firmly, turn on vacuum cleaner.</li> <li>2. Reset circuit breaker or replace fuse.</li> <li>3. Allow to cool 30-50 minutes and thermal protector will reset itself.</li> <li>4. Check with a good appliance or lamp. Have outlet properly serviced.</li> </ol>
Poor job of dirt pick up	<ol style="list-style-type: none"> <li>1. Full or clogged dust bin.</li> <li>2. Worn agitator.</li> <li>3. Clogged nozzle.</li> <li>4. Clogged hose.</li> <li>5. Hole in hose.</li> <li>6. Broken belt</li> <li>7. Motor protection system activated.</li> <li>8. Dirty filters.</li> <li>9. Dust bin not assembled correctly.</li> </ol>	<ol style="list-style-type: none"> <li>1. Empty dust bin.</li> <li>2. Take to your nearest Panasonic Service Center.</li> <li>3. Check for clogs.</li> <li>4. Check for clogs.</li> <li>5. Take to your nearest Panasonic Service Center.</li> <li>6. Replace belt.</li> <li>7. Check for clogs.</li> <li>8. Clean or change primary filter and/or change exhaust filter.</li> <li>9. Remove dust bin and reinstall.</li> </ol>
Light won't work.	<ol style="list-style-type: none"> <li>1. Burned out light bulb.</li> </ol>	<ol style="list-style-type: none"> <li>1. Change light bulb.</li> </ol>
Agitator does not turn.	<ol style="list-style-type: none"> <li>1. Carpet/Bare floor selector in Bare Floor position</li> <li>2. Broken belt.</li> <li>3. Tripped overload protector in nozzle.</li> <li>4. Handle in full upright position.</li> </ol>	<ol style="list-style-type: none"> <li>1. Select <b>CARPET</b> position.</li> <li>2. Replace belt.</li> <li>3. Remove any items that may be caught or jammed, then reset. If vacuum cleaner starts and stops again, clean agitator and end caps, then reset.</li> <li>4. Move handle from upright position.</li> </ol>
Air flow restricted with attachment use. Sound changes.	<ol style="list-style-type: none"> <li>1. Tool use restricts air flow.</li> <li>2. New carpet fuzz clogged air path.</li> </ol>	<ol style="list-style-type: none"> <li>1. Check tools for fuzz, lint, pet hair or other debris.</li> <li>2. See CLOG REMOVAL section and clean hose.</li> </ol>

**Panasonic Canada Inc.**  
5770, Ambler Drive, Mississauga (Ontario) L4W 2T3

**PANASONIC PRODUCT - LIMITED WARRANTY**

Panasonic Canada Inc. warrants this product to be free from defects in material and workmanship under normal use and for a period as stated below from the date of original purchase agrees to, at its option either (a) repair your product with new or refurbished parts, (b) replace it with a new or a refurbished equivalent value product, or (c) refund your purchase price. The decision to repair, replace or refund will be made by Panasonic Canada Inc.

**Vacuum Cleaner - One (1) year, parts and labour**

This warranty is given only to the original purchaser, or the person for whom it was purchased as a gift, of a Panasonic brand product mentioned above sold by an authorized Panasonic dealer in Canada and purchased and used in Canada, which product was not sold "as is", and which product was delivered to you in new condition in the original packaging.

**IN ORDER TO BE ELIGIBLE TO RECEIVE WARRANTY SERVICE HEREUNDER, A PURCHASE RECEIPT OR OTHER PROOF OF DATE OF ORIGINAL PURCHASE, SHOWING AMOUNT PAID AND PLACE OF PURCHASE IS REQUIRED**

**LIMITATIONS AND EXCLUSIONS**

This warranty ONLY COVERS failures due to defects in materials or workmanship, and DOES NOT COVER normal wear and tear or cosmetic damage. The warranty ALSO DOES NOT COVER damages which occurred in shipment, or failures which are caused by products not supplied by Panasonic Canada Inc., or failures which result from accidents, misuse, abuse, neglect, mishandling, misapplication, alteration, faulty installation, set-up adjustments, misadjustment of consumer controls, improper maintenance, power line surge, lightning damage, modification, introduction of sand, humidity or liquids, commercial use such as hotel, office, restaurant, or other business or rental use of the product, or service by anyone other than a Authorized Servicer, or damage that is attributable to acts of God.

Parts such as disposable dust bags, filters, belts, light bulbs and agitator brushes are not covered by this warranty.

THIS EXPRESS, LIMITED WARRANTY IS IN LIEU OF ALL OTHER WARRANTIES, EXPRESS OR IMPLIED, INCLUDING ANY IMPLIED WARRANTIES OF MERCHANTABILITY AND FITNESS FOR A PARTICULAR PURPOSE. IN NO EVENT WILL PANASONIC CANADA INC. BE LIABLE FOR ANY SPECIAL, INDIRECT OR CONSEQUENTIAL DAMAGES RESULTING FROM THE USE OF THIS PRODUCT OR ARISING OUT OF ANY BREACH OF ANY EXPRESS OR IMPLIED WARRANTY. (As examples, this warranty excludes damages for lost time, travel to and from the Authorized Servicer, loss of or damage to media or images, data or other memory or recorded content. This list of items is not exhaustive, but for illustration only.)

In certain instances, some jurisdictions do not allow the exclusion or limitation of incidental or consequential damages, or the exclusion of implied warranties, so the above limitations and exclusions may not be applicable. This warranty gives you specific legal rights and you may have other rights which vary depending on your province or territory.

**WARRANTY SERVICE**

For product operation and information assistance, please contact:

**PRODUCT OPERATION ASSISTANCE**

Customer Care Centre:

Telephone #: 1-800-561-5505

Fax #: (905) 238-2360

Email link: "Support → contact us → email" on [www.panasonic.ca](http://www.panasonic.ca)

**PRODUCT REPAIRS**

Please locate your nearest Authorized Servicentre.

Link: "Support → Panasonic Servicentre® locator" on [www.panasonic.ca](http://www.panasonic.ca)

**IF YOU SHIP THE PRODUCT TO A SERVICENTRE**

Carefully pack and send prepaid, adequately insured and preferably in the original carton.  
Include details of the defect claimed, and proof of date of original purchase.

## WHAT TO DO WHEN SERVICE IS NEEDED

If your Panasonic Vacuum Cleaner needs service, look in the yellow pages of the telephone book under HOME APPLIANCE SERVICE for your nearest Panasonic Services Company ("PASC") Factory Servicenter, or PASC authorized Servicenter, or call, 1-800-211-PANA (7262) toll free to find a convenient servicenter. **DO NOT send the product to the Executive or Regional Sales offices. They are NOT equipped to make repairs.**

If you ship the product

Carefully pack and send it prepaid, adequately insured and preferably in the original carton. Attach a postage-paid letter to the outside of the carton, which contains a description of your complaint. **DO NOT send the product to the Executive or Regional Sales Offices. They are NOT equipped to make repairs.**

PANASONIC CONSUMER ELECTRONICS COMPANY  
DIVISION OF PANASONIC CORPORATION OF NORTH AMERICA

One Panasonic Way  
Secaucus, New Jersey 07094  
World Wide Web Address  
<http://www.panasonic.com>

## What to do when service is needed Service après-vente (Canada)

### WARRANTY SERVICE

For product operation and information assistance, please contact your Dealer or our Customer Care Centre at:  
Telephone #: 1-800-561-5505 Fax #: (905) 238-2360 Web: [www.panasonic.ca](http://www.panasonic.ca)

For product repairs, please locate your nearest Authorized Servicecentre.

Link: "Support → Panasonic Servicecentre locator" on [www.panasonic.ca](http://www.panasonic.ca)

### RÉPARATION SOUS GARANTIE

Pour de l'aide sur le fonctionnement de l'appareil ou pour toute demande d'information, veuillez contacter votre détaillant ou notre service à la clientèle au :

N° de téléphone : 1-800-561-5505 N° de télécopieur : (905) 238-2360 Site Internet : [www.panasonic.ca](http://www.panasonic.ca)

Pour la réparation des appareils, veuillez localiser le centre de service agréé le plus près de votre domicile.

Lien: "Support à la clientèle → Centres de service" sur le site [www.panasonic.ca](http://www.panasonic.ca).

## Cuando necesita servicio

Si su aspiradora Panasonic necesita servicio, busque el Centro de Servicio Panasonic o un Centro de Servicio PASC autorizado más cercano bajo "Servicio de Electrodomésticos" en las páginas amarillas de la guía de teléfonos o llame gratis al 1-800-211-PANA (7262) para encontrar un centro de servicio conveniente. No mande el producto a las Executive o Regional Sales Offices. No están equipadas para arreglar estos productos.

Si manda el producto

Empaquete con cuidado en el cartón original si posible y mándelo prepago y con seguro suficiente. Ponga una carta con sellos en la que describe su problema con el producto en el exterior del cartón. No mande el producto a las Executive o Regional Sales Offices. No están equipadas para arreglar estos productos.

PANAMEX COMPANY  
DIVISION OF PANASONIC CORPORATION OF NORTH AMERICA

One Panasonic Way  
Secaucus, New Jersey 07094  
World Wide Web Address  
<http://www.panasonic.com>