

Panasonic®

Operating Instructions Manuel d'utilisation *Instrucciones de operación*

VACUUM CLEANER

Aspirateur

Aspiradora

MC-UL975

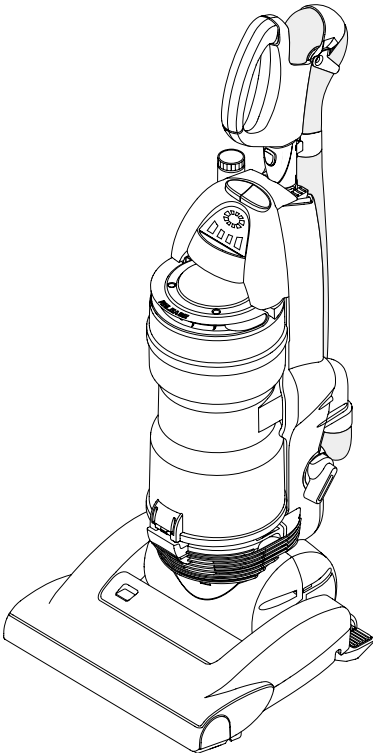

**Before operating your vacuum cleaner,
please read these instructions completely.**

Avant d'utiliser l'appareil, il est recommandé
de lire attentivement ce manuel.

*Antes de usar su aspiradora, lea
completamente estas instrucciones por favor.*

CONSUMER INFORMATION

Please read **IMPORTANT SAFETY INSTRUCTIONS** on page 5 before use. Read and understand all instructions.

TO OUR VALUED CUSTOMER

We are very pleased to welcome you to the Panasonic family of products. Thank you for purchasing this product. Our intent is that you become one of our many satisfied customers.

Proper assembly and safe use of your vacuum cleaner are your responsibilities. Your vacuum cleaner is intended only for household use. The vacuum cleaner should be stored in a dry, indoor area. Read the Operating Instructions carefully for important use and safety information.

Special care is required when vacuuming certain types of carpet or floor covering. Always check the carpet or floor covering manufacturer's recommended cleaning instructions before vacuuming.

PLEASE PAY CLOSE ATTENTION TO ALL WARNING AND CAUTION STATEMENTS.

WARNING

WARNING statements are designed to alert you to the possibility of personal injury, loss of human life, and/or damage to the vacuum cleaner and/or personal property if the instructions given are not followed.

CAUTION

CAUTION statements are designed to alert you to the possibility of damage to the vacuum cleaner and/or personal property if the instructions given are not followed.

WARNING

TO AVOID ELECTRICAL SHOCK

Never vacuum damp or wet surfaces or liquids.
DO NOT store vacuum cleaner outdoors.
Replace worn or frayed power cord immediately.
Unplug from outlet when not in use and before servicing.

TO AVOID ACCIDENTS

Except for hand-held cleaners, keep vacuum cleaner on floor - not chairs, tables, steps, stairs, etc.
Store vacuum cleaner promptly after each use to prevent accidents such as tripping over power cord or vacuum cleaner.
Use vacuum cleaner and accessories only in a manner intended by the manufacturer.
The use of an extension cord is not recommended.

IMPORTANT SAFETY INSTRUCTIONS

When using your vacuum cleaner, basic precautions should always be followed, including the following:

Read all instructions in this manual before assembling or using your vacuum cleaner.

WARNING To reduce the risk of fire, electrical shock, injury:

1. **Use** your vacuum cleaner only as described in this manual. Use only with Panasonic recommended attachments.
2. **Disconnect** electrical supply before servicing or cleaning out the brush area. Failure to do so could result in the brush unexpectedly starting, causing personal injury from moving parts.
3. **Do not** leave vacuum cleaner when plugged in. Unplug from outlet when not in use and before servicing.
4. **To reduce** the risk of electrical shock - Do not use outdoors or on wet surfaces.
5. **Do not** allow to be used as a toy. Close attention is necessary when used by or near children.
6. **Do not** use with a damaged cord or plug. If vacuum cleaner is not working as it should, has been dropped, damaged, left outdoors, or dropped in water, return it to a Panasonic Service Center.
7. **Do not** pull or carry by cord, use cord as a handle, close a door on cord, or pull cord around sharp edges or corners. Do not run vacuum cleaner over cord. Keep cord away from heated surfaces.
8. **Do not** unplug by pulling on cord. To unplug, grasp the plug, not the cord.
9. **Do not** handle plug or vacuum cleaner with wet hands.
10. **Do not** put any objects into openings.
11. **Do not** use with any opening blocked; keep free of dust, lint, hair, and anything that may reduce air flow.
12. **Keep** hair, loose clothing, fingers, and all parts of body away from openings and moving parts.
13. **Turn off** all controls before unplugging.
14. **Use** extra care when cleaning on stairs. Do not put on chairs, tables, etc. Keep on floor.
15. **Do not** use vacuum cleaner to pick up flammable or combustible liquids (gasoline, cleaning fluid, perfumes, etc.), or use in areas where they may be present. The fumes from these substances can create a fire hazard or explosion.
16. **Do not** pick up anything that is burning or smoking, such as cigarettes, matches, or hot ashes.
17. **Do not** use vacuum cleaner without dust bin and/or filters in place.
18. **Unplug** before connecting Air Turbine.
19. **You are** responsible for making sure that your vacuum cleaner is not used by anyone unable to operate it properly.

SAVE THESE INSTRUCTIONS

THIS VACUUM CLEANER IS INTENDED FOR HOUSEHOLD USE ONLY

NOTE: Before you plug in your Panasonic vacuum cleaner, make sure that the voltage indicated on the rating plate located at the back of the vacuum cleaner is the same as your local electrical supply.

TABLE OF CONTENTS

CONSUMER INFORMATION	2
IMPORTANT SAFETY INSTRUCTIONS	5
PARTS IDENTIFICATION	10,11
FEATURE CHART	11
ASSEMBLY	12
Attaching Components	12
FEATURES	14
AEROBLAST	14
Dirt Sensor	16
Automatic Self Adjusting Nozzle	16
Overload Protector	18
Edge Cleaning	18
TO OPERATE VACUUM CLEANER	20
Adjustable Handle	20
Cord Hook	20
Locking Notch	20
Power Cord	22
ON/OFF Switch	22
Carpet/Bare Floor Selector	22
Body Release	24
Adjustable Handle Release	26
Using Tools	28
Tools	30
ROUTINE CARE OF VACUUM CLEANER	32
Dust Bin Cleaning	32
Cleaning HEPA Primary Filter	36
Cleaning Pre-Filter	38
Replacing HEPA Exhaust Filter	40
Cleaning Dirt Sensor Optics	42
Thermal Protector	44
Removing and Installing Lower Plate	46
Replacing Belt	48
Replacing Headlight Bulb	50
Cleaning Exterior and Tools	52
Cleaning Agitator	52
Removing Clogs	54
BEFORE REQUESTING SERVICE	56
WARRANTY	59, 60
WHAT TO DO WHEN SERVICE IS NEEDED	64

PARTS IDENTIFICATION

Nomenclature Identificación de piezas

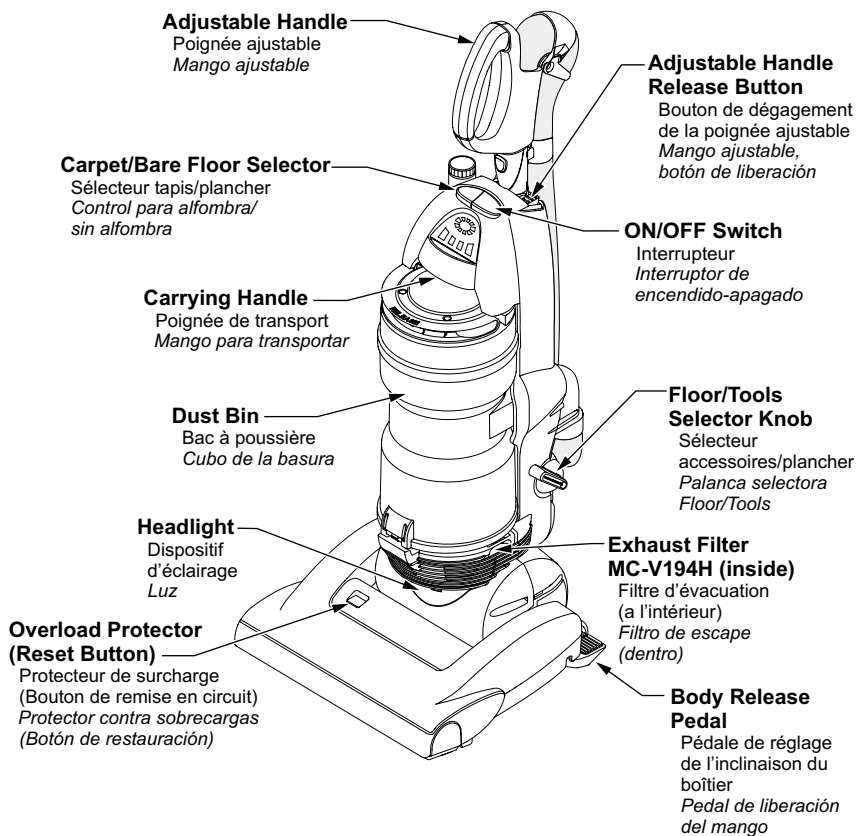

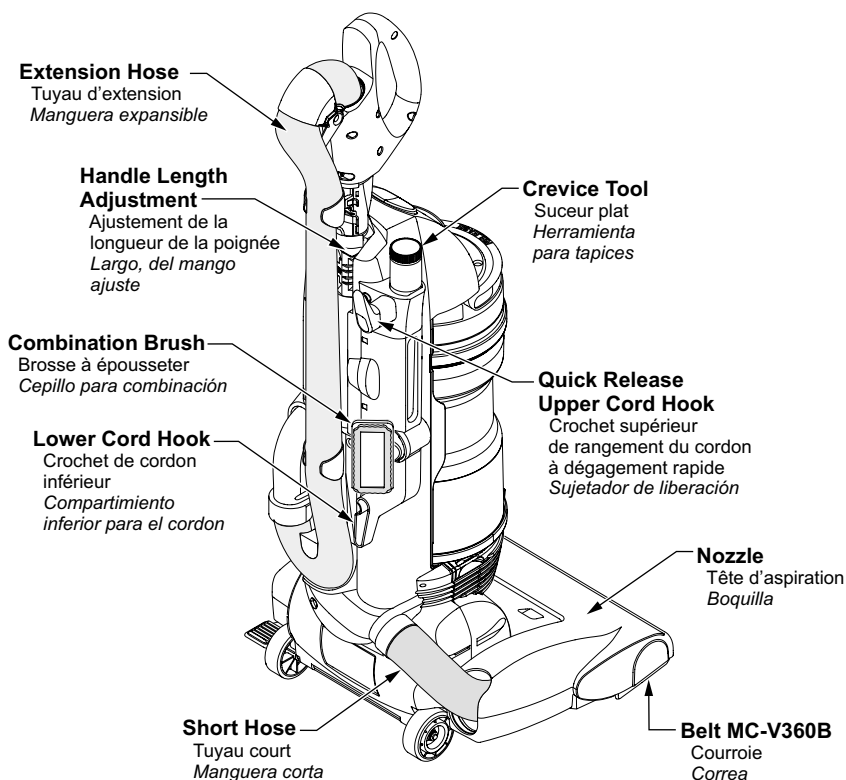

FEATURE CHART

Power	Dirt Sensor	Headlight	Cord Length	Bare Floor
120V AC(60Hz)	Yes	Yes	35 Ft	Yes

Tableau des caractéristiques

Alimentation	Détecteur de poussière	Dispositif d'éclairage	Longueur du cordon	Position plancher
120 V c.a. (60 Hz)	Oui	Oui	10,7m (35 pi)	Oui

Diagrama de características

Voltaje	Sensor de basura	Luz	Extensión de cordón	Uso sin alfombra
120 V c.a. (60 Hz)	Si	Si	10.7m (35 pi)	Si

ASSEMBLY

Attaching Components

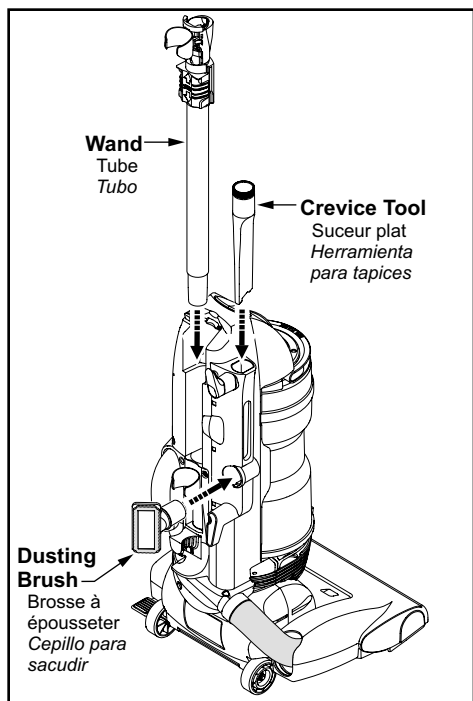

CAUTION

DO NOT plug in until assembly is complete.

- Insert wand into vacuum cleaner until it locks in place.
- Insert crevice tool and dusting brush into storage locations on the vacuum cleaner.
- Insert handle into wand.
- Insert hose into clips on the wand and the back of the vacuum cleaner.
- Wrap power cord clockwise around upper and lower cord hooks as shown.

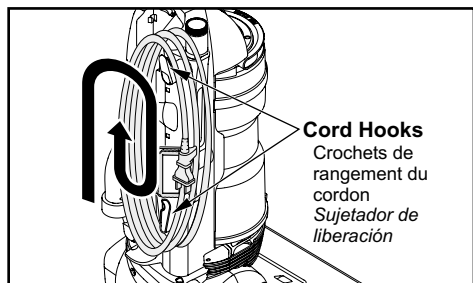
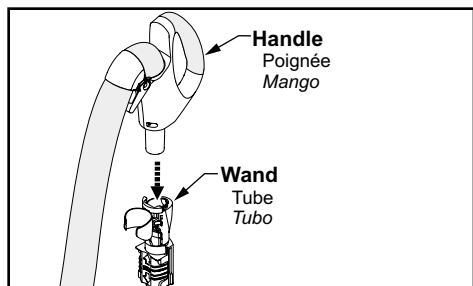

FEATURES

AEROBLAST

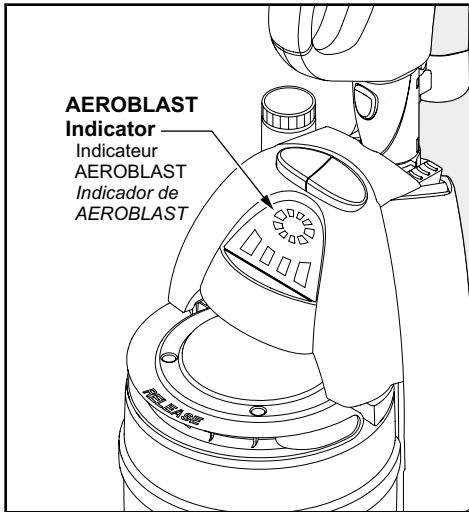

Your Panasonic vacuum cleaner is equipped with the latest technology.

- When the vacuum cleaner is turned on, AEROBLAST automatically cleans the primary filter for 15-20 seconds.
- During the cleaning cycle, it is normal for the vacuum cleaner to make a series of noises and the **FILTER CLEANING** lights on the display will flash to indicate the filter is being cleaned.
- You may use your vacuum during the cleaning cycle. It is not necessary to wait until the cleaning cycle is finished.

Note:

If the AEROBLAST indicator lights stay lit when the vacuum cleaner is turned on, the dust bin is either not installed, or not installed properly.

Dirt Sensor

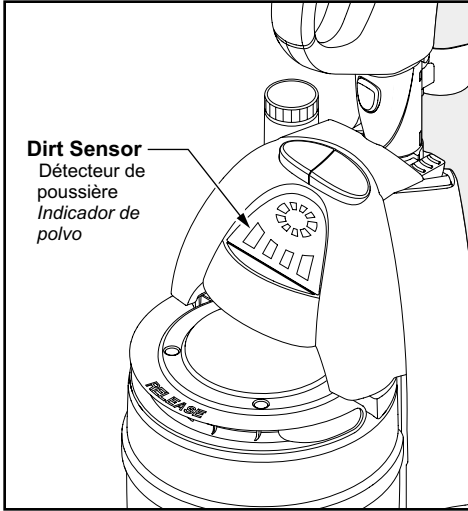

- The electronic dirt sensor is a feature which will detect particles as they pass through the vacuum cleaner.
- The dirt sensor indicator is located on the front of the vacuum cleaner as illustrated.
- When there is little or no dirt present the dirt sensor is green.
- With normal dirt concentration the dirt sensor is amber.
- With heavy dirt concentration the dirt sensor is amber and red.

Automatic Self Adjusting Nozzle

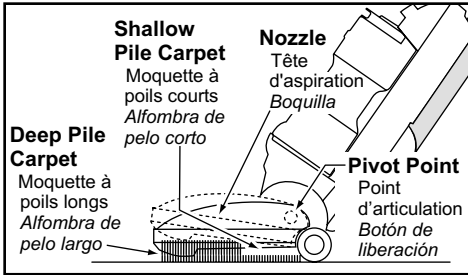

- The nozzle of your Panasonic vacuum cleaner automatically adjusts to any carpet pile height.
- Feature allows nozzle to float evenly over carpet pile surfaces.
- No manual adjustments required.

Overload Protection

OVERLOAD PROTECTION RESET button

Bouton de remise en circuit
de la protection de surcharge
Protector contra sobrecargas
(Botón de restauración)

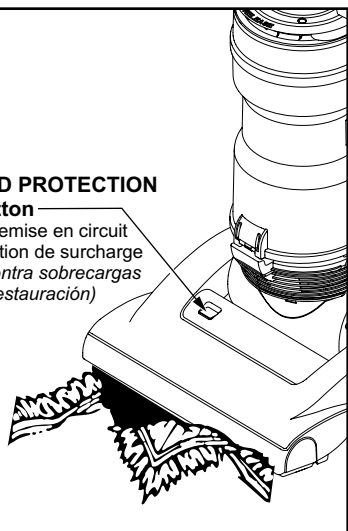

- The OVERLOAD PROTECTION RESET button stops the nozzle motor when the brush jams to prevent belt breakage.

NOTE: The vacuum cleaner motor will continue to run.

TO CORRECT PROBLEM:

- Unplug electrical cord.
- Check nozzle areas for excessive lint buildup or jamming.
- Clean jammed area.

TO RESET:

- Press reset button on top of the nozzle. Plug in and turn on vacuum cleaner.

Edge Cleaning

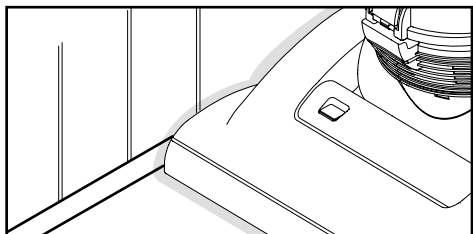

- Edge cleaning feature enables improved cleaning of carpets near walls and furniture.

TO OPERATE VACUUM CLEANER

Adjustable Handle

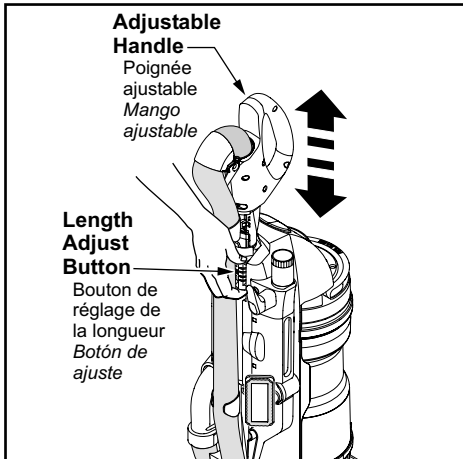

- Press the handle **LENGTH ADJUST** button located on the back of the vacuum cleaner.
- Raise or lower the adjustable handle to the desired operating position.

CAUTION

DO NOT carry the vacuum cleaner by the adjustable handle. Use **ONLY** the carrying handle located on the front of the vacuum cleaner.

Cord Hook

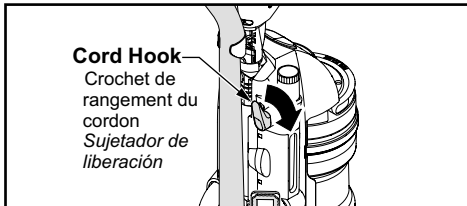

- Detach plug head from power cord.
- Rotate cord hook down to release cord.
- Return the cord hook to the upright position before attempting to rewind the cord.

Locking Notch

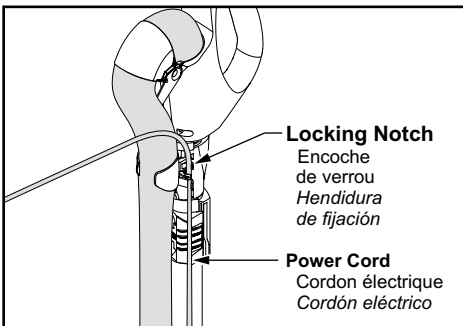

- Make sure the power cord is placed into the locking notch as shown.

Note: This helps keep the power cord out from under the vacuum cleaner agitator.

Power Cord

Note: To reduce the risk of electrical shock, this vacuum cleaner has a polarized plug, one blade is wider than the other. This plug will fit in a polarized outlet only one way. If the plug does not fit fully in the outlet, reverse the plug. If it still does not fit, contact a qualified electrician to install the proper outlet. **DO NOT CHANGE THE PLUG IN ANY WAY.** Only use outlets near the floor.

ON / OFF Switch

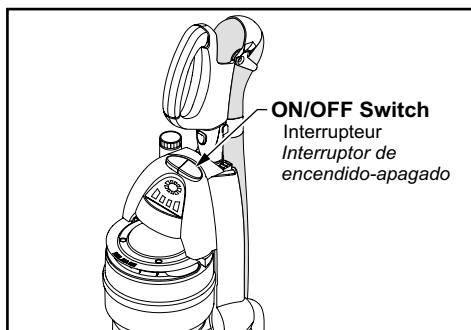

- Plug the power cord into an outlet near the floor.
- Press the switch to turn the vacuum cleaner on.
- When finished vacuuming, press the switch again to turn the vacuum cleaner off.
- Unplug the cord from the outlet when not in use.

Carpet/Bare Floor Selector

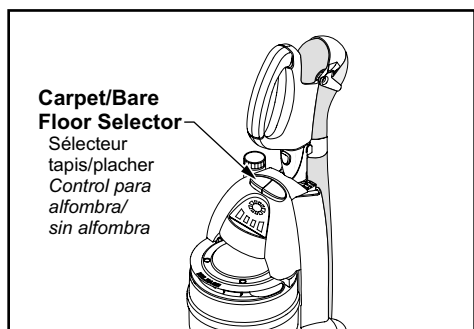

- Selector should be placed in **BARE FLOOR (TOOLS)** position when using vacuum cleaner on bare floors and when using tools. The agitator does not rotate in the **BARE FLOOR (TOOLS)** position.
- Selector should be placed in **CARPET** position when using vacuum cleaner on carpeted floors.

Body Release

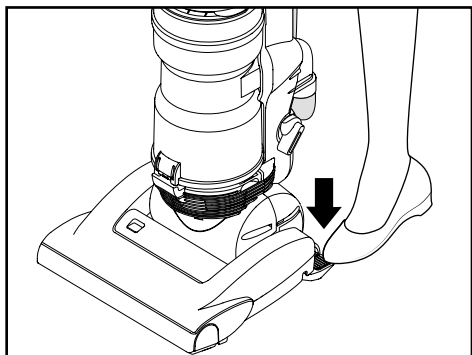

- Your vacuum cleaner is equipped with three (3) position body release;
 - Upright position (locked)
 - Middle position (normal use)
 - Low position (getting under furniture)

- Release the body by pressing down on the body release pedal with your foot and pulling back and down on the handle with your hand.

- Move the vacuum cleaner to upright position for storage and tool use.

CAUTION

DO NOT press the handle quick release button when the vacuum cleaner is in use.

Adjustable Handle Release

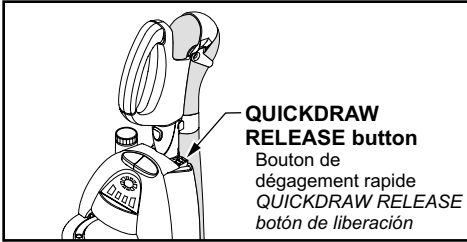

- Remove the handle by pushing the QUICKDRAW RELEASE button.
- Lift adjustable handle assembly out of the vacuum cleaner.
- With the handle free from the vacuum cleaner it now can be used as an extension wand. Length can be changed when being used as a wand.
- Add attachments to suit your cleaning needs.
- Place adjustable handle securely back into the vacuum cleaner by aligning slots on handle assembly with tabs on body as shown.

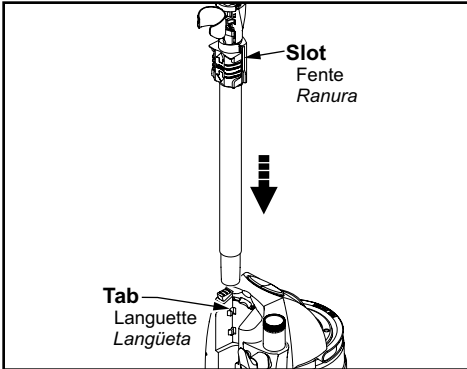

Using Tools

Handle Quick Release

Bouton de dégagement rapide de la poignée
Botón de liberación rápida del mango

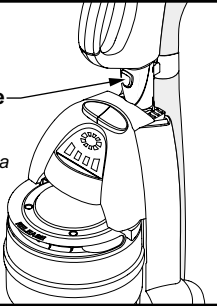

- Press the handle quick release button on the wand to remove the handle to use tools on the handle.
- Press the adjustable handle release button to remove the extension wand from the vacuum cleaner to use tools on the extension wand.
- Rotate the selector knob up to **TOOLS** when using attachments. Return selector knob down to **FLOOR** setting when not using attachments.

QUICKDRAW RELEASE button

Bouton de dégagement rapide
QUICKDRAW RELEASE
botón de liberación

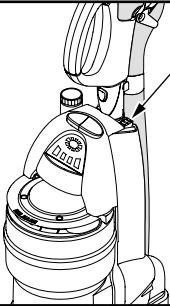

- Add attachments to suit your cleaning needs. (see **TOOLS** for suggested attachment usage)

⚠ CAUTION

When using attachments, place one hand on the vacuum cleaner to prevent pulling the vacuum cleaner over.

Floor/Tools Selector Knob

Sélecteur accessoires/
plancher
Palanca selectora
Floor/Tools

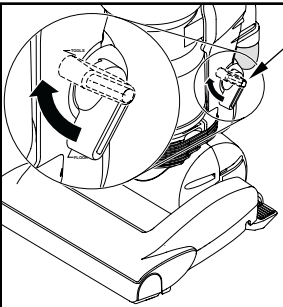

TOOLS

FLOOR

Tools

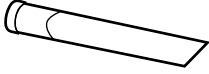

- The Crevice Tool may be used on the following items:
 - Furniture
 - Cushions
 - Drapes
 - Stairs
 - Walls

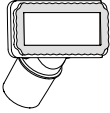

- The Dusting Brush may be used on the following items:
 - Furniture
 - Drapes
 - Stairs
 - Walls



- The Floor Brush may be used on the following items:
 - Stairs
 - Floors



- The Air Turbine may be used on the following items:
 - Furniture
 - Stairs
- Operating instructions for the Air Turbine are included with the product.

Note: Always clean tools before using.

ROUTINE CARE OF VACUUM CLEANER

Performing the following tasks will keep your new Panasonic vacuum cleaner operating at peak performance levels and will ensure these high levels for years to come. Check the **BEFORE REQUESTING SERVICE** section in this manual for recommendations on performing some of these tasks to help solve various problems that may occur.

WARNING Electrical Shock or Personal Injury Hazard

Disconnect the electrical supply before servicing or cleaning the vacuum cleaner. Failure to do so could result in electrical shock or personal injury from vacuum cleaner suddenly starting.

Dust Bin Cleaning

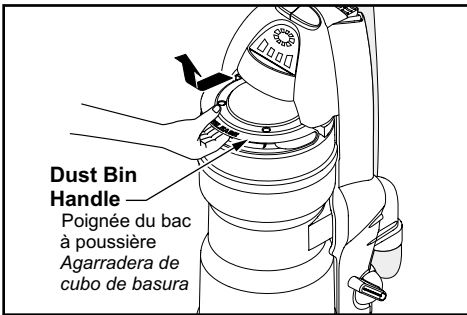

- Always empty the dust bin when dirt level reaches the “MAX” line.
- Grasp the handle on the top of the dust bin. Lift up and out to remove dust bin from vacuum cleaner.
- Remove any clogs that might be located in the pre-filter. (See “Cleaning Pre-Filter”)

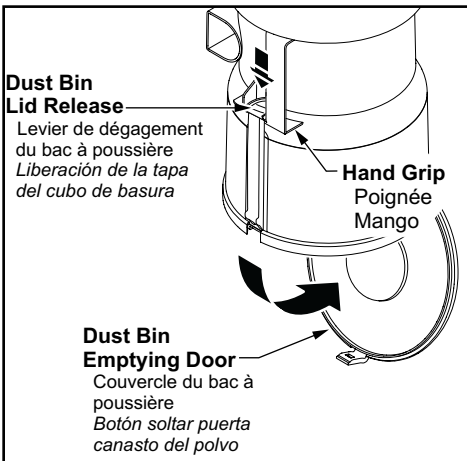

CAUTION

Be sure to hold the dust bin over a proper trash container prior to releasing the door of the dust bin.

- Press dust bin lid release and the dust bin will open and the debris will fall out.

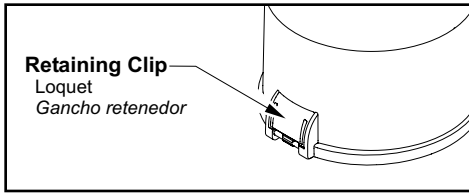

➤ A retention clip is located on the hinge area of the dust bin.

➤ This clip may release when the dust bin door is opened to prevent damage to the door or the dust bin.

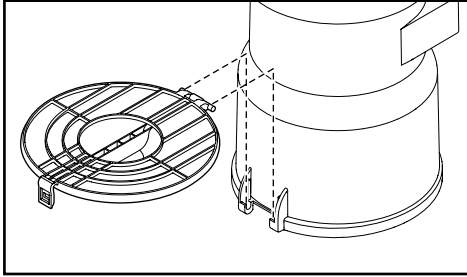

➤ To reassemble, slide the tabs on the dust bin door into the slots on the dust bin.

➤ Secure in place using the retention clip.

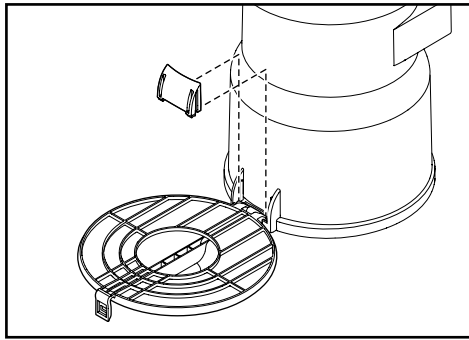

TO REPLACE DUST BIN

➤ After the dust bin is empty of debris, firmly close the door. Make sure you hear a “click” sound to indicate that the door is fully latched.

➤ Place dust bin back into vacuum cleaner by inserting the bottom first and tilting back.

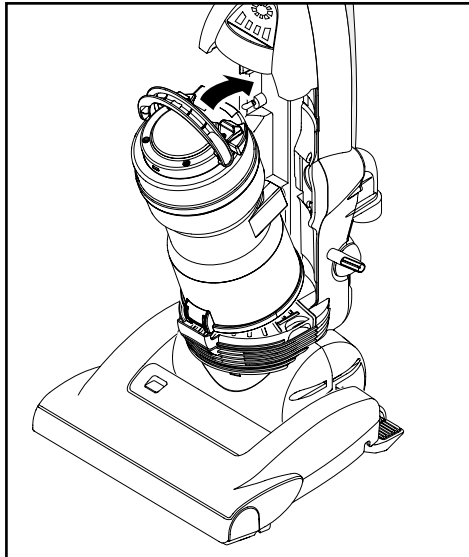

➤ Push forward and lower dust bin handle to lock dust bin in place.

Cleaning HEPA Primary Filter

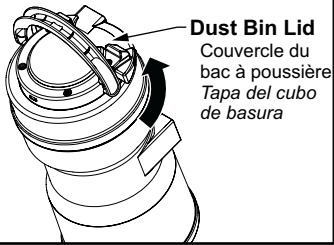

- When dust bin is removed, rotate dust bin lid assembly counter-clockwise and lift off.
- Remove filter from dust bin by lifting filter frame as indicated.
- Clean primary filter by gently tapping over a trash container.

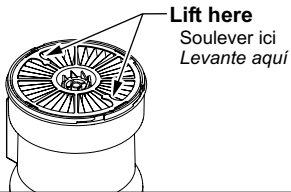

- Rinse with water only as needed, do not use any detergent or soap. Allow filter to dry for 24 hours before placing back into vacuum cleaner.

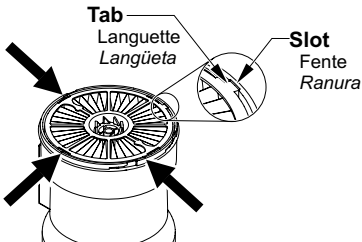

- The filter is keyed to the dust bin and will only install one way. To reinstall filter into dust bin, align the tabs on the filter cartridge with the corresponding slots in the dust bin.
- Replace lid by lining up indicator on lid with UNLOCK mark on dust bin.

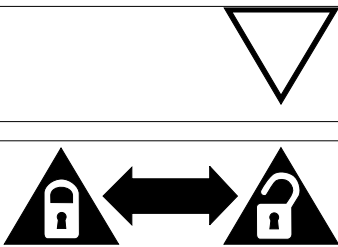

- Rotate lid clockwise to lock in place.

Cleaning Pre-Filter

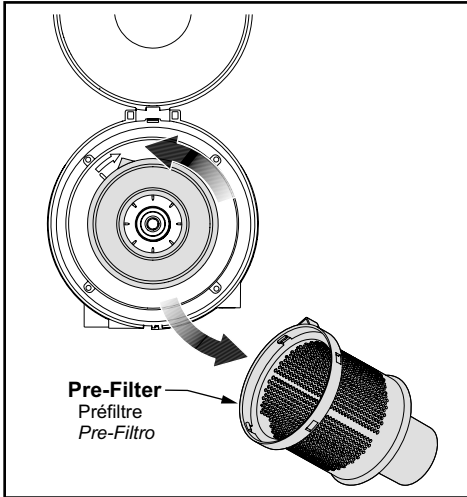

- Empty dust bin.
- While dust bin is open, grasp pre-filter and rotate counter-clockwise to remove.
- Clean pre-filter by gently tapping over a trash container.
- Rinse with water only as needed, do not use any detergent or soap.
- Allow pre-filter to dry for 24 hours before placing back into vacuum cleaner.

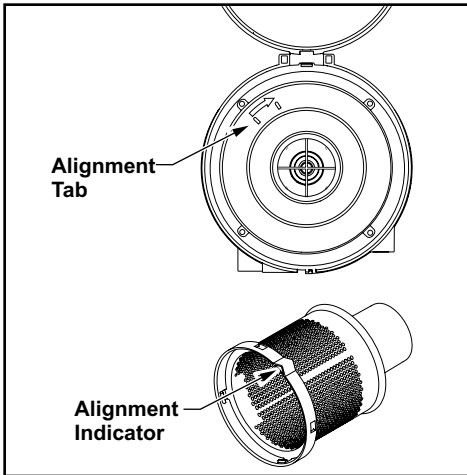

- To Reinstall:**
- Place dust bin upside down on a table or flat surface with the lid facing away
 - Align the indicator on the pre-filter with the alignment tab inside dust bin.
 - Rotate pre-filter clockwise to lock in place.

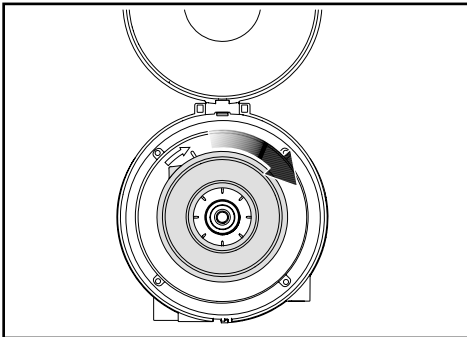

Replacing HEPA Exhaust Filter

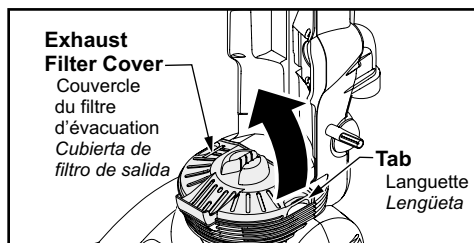

- The HEPA exhaust filter removes dirt from exhaust air.
- Check filter after emptying dust bin. Replace when dirty.
- To remove, lift at tab.

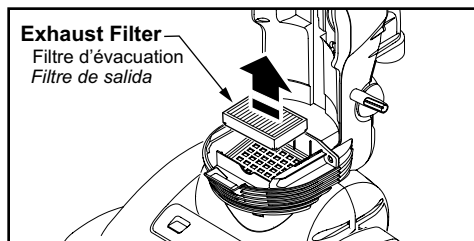

- Grasp the exhaust filter and pull out to remove.
- Ensure foam edge of the filter is facing towards the vacuum cleaner when placing filter into filter compartment.

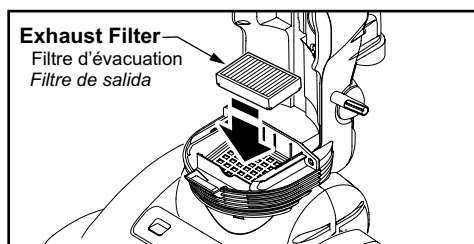

- Reinstall exhaust filter cover by placing the cover on the body and snapping into place as shown.
- * Filter cannot be cleaned and should be replaced at least once each year.

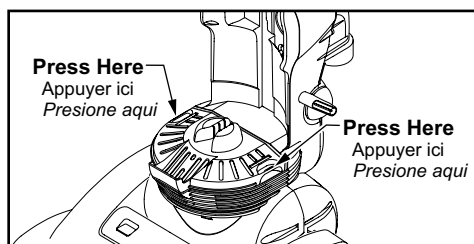

Cleaning Dirt Sensor Optics

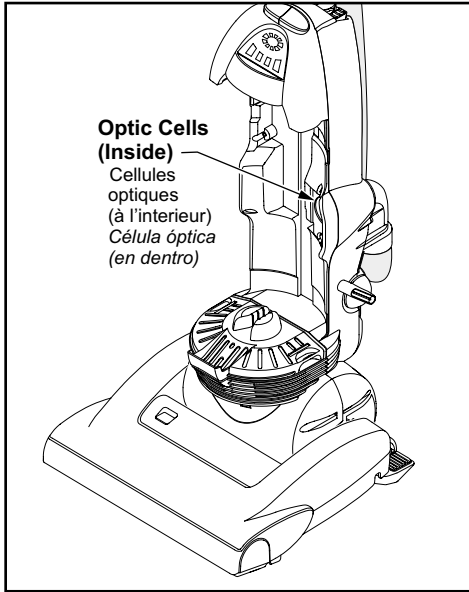

- The dirt sensor optics consist of two optic cells located inside the suction inlet. Occasionally, it may become necessary to clean the two optic cells to assure maximum performance.
- Clean optic cells:
 - When dirt or dust adheres to the optic cells.
 - Whenever the dust bin is cleaned.
- To clean the dirt sensor optics, remove dust bin from vacuum cleaner.
- Wipe the optic cells with a soft, dry cloth.
- Never use cleaners or liquids as they can help speed the recoating of the optic cells and make it necessary to clean them much sooner than normal.

Thermal Protector

- This vacuum cleaner has a thermal protector which automatically trips to protect the vacuum cleaner from overheating.
- If a clog prevents the normal flow of air to the motor, the thermal protector turns the motor off automatically. This allows the motor to cool in order to prevent possible damage to the vacuum cleaner.

TO CORRECT PROBLEM:

- Turn the vacuum cleaner off and unplug the power cord from the outlet to allow the vacuum cleaner to cool and the thermal protector to reset.
- Check for and remove clogs, if necessary. Also check and replace any clogged filters and empty dust bin if necessary.
- Wait approximately thirty (30) minutes and plug the vacuum cleaner in and turn back on to see if the motor protector has reset.

! WARNING Electrical Shock or Personal Injury Hazard

Disconnect the electrical supply before servicing or cleaning the vacuum cleaner. Failure to do so could result in electrical shock or personal injury from vacuum cleaner suddenly starting.

Removing and Installing Lower Plate

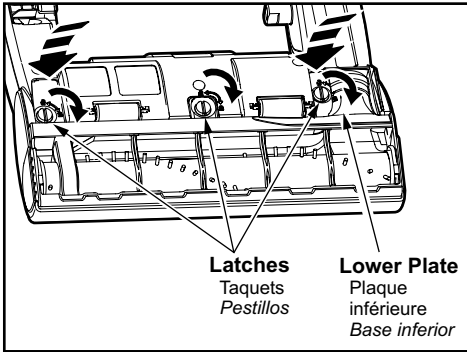
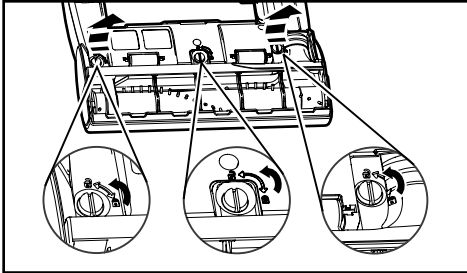

- **Before servicing any parts, disconnect vacuum cleaner from electrical outlet.**
- **Always place paper under nozzle whenever lower plate is removed to protect floor.**
- **Place body in upright position and turn vacuum cleaner over to expose lower plate.**
- **Release lower plate by rotating the lower plate latches to the UNLOCK position.**
- **Remove lower plate and remove any residue that may exist in belt area.**
- **Reinstall lower plate by hooking front end of lower plate into slots on front of nozzle.**
- **Press lower plate onto nozzle and secure by rotating the lower plate latches to the LOCK position.**

Replacing Belt

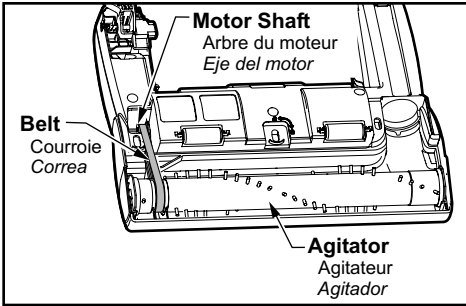

- Replace belt whenever a burning rubber smell caused by excessive slippage occurs.
- Remove lower plate. See “Removing and Installing Lower Plate”

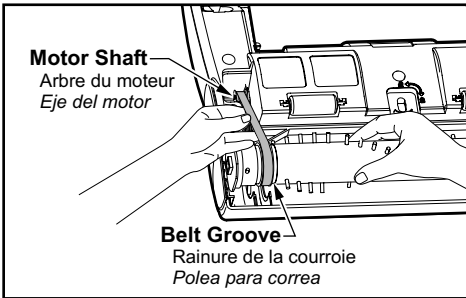

- Remove agitator by carefully lifting out.
- Remove worn or broken belt.
- Clean agitator and the end caps.

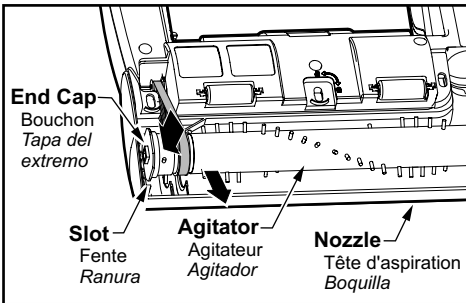

- Loop new belt around motor shaft and agitator belt groove; see illustration for correct belt routing.
- Reinstall agitator back into nozzle housing grooves.
- After reinstalling the agitator, turn it by hand to make sure that belt is not twisted or pinched and that all rotating parts turn freely.
- Reinstall lower plate. Ensure tabs are locked into slots.

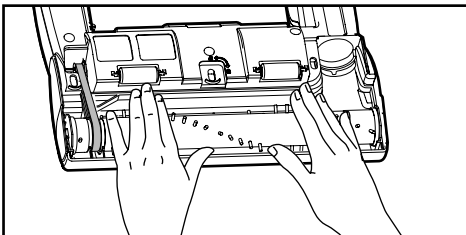

Replacing Headlight Bulb

Flat Screwdriver

Tournevis à lame plate
Desarmador plano

Headlight Lens

Lentille de la lampe
Lente de la luz

Slots
Fentes
Ranuras

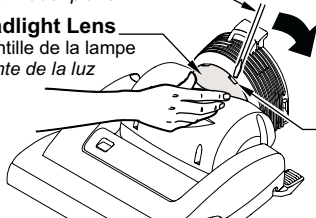

- Disconnect power cord from electrical outlet. Lower body to lay the vacuum cleaner flat.
- Pry out light lens at slots by inserting screwdriver into slot, pushing down on the lens and rotating the screwdriver handle toward unit.
- Remove the light bulb by pulling straight out.
- To replace the light bulb carefully insert securely into slot. Replace lens cover.

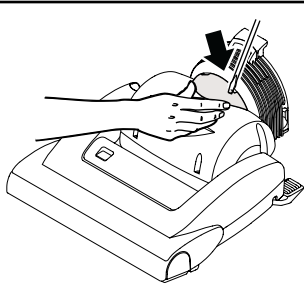
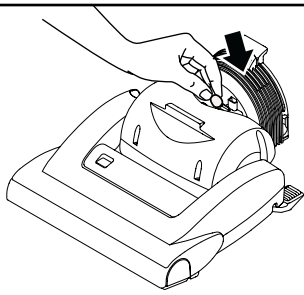
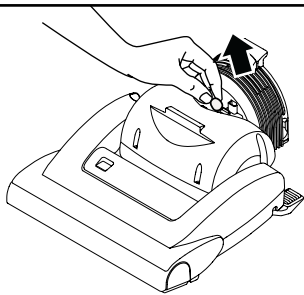

CAUTION

Do not use a bulb rated over 9W (13V). During extended use, heat from the bulb could overheat surrounding plastic parts.

- Replace lens cover by inserting bottom tab of lens into slot then applying pressure to top tabs.
- A “popping” sound indicates lens is snapped properly in place.

Cleaning Exterior and Tools

- Unplug cord from wall outlet.
- Clean exterior using a clean, soft cloth that has been dipped in a solution of mild liquid detergent and water and wrung dry.
- DO NOT drip water on the vacuum cleaner and wipe dry after cleaning.
- DO NOT clean tools in dishwasher or clothes washer.
- Wash tools in warm soapy water, rinse and air dry.
- DO NOT use tools if they are wet.

Cleaning Agitator

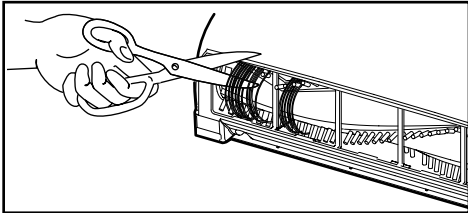

- Clean agitator after every five uses.
- Turn vacuum cleaner over, exposing the agitator.
- Cut off any carpet pile and lint entangled around agitator with a pair of scissors.

Removing Clogs

If the vacuum cleaner does not seem to have adequate suction, first check if the dust bin is full or if a filter is clogged.

- Check the handle and extension wand area.
- Remove handle by pressing handle quick release button.
- Visually inspect the hose and the base area into which the hose is connected.
- Remove any visible clog.
- Plug in the vacuum cleaner and turn it on.
- Stretch the hose to maximum length and then allow the hose to return to its storage length.
- Turn off and unplug the vacuum cleaner.
- Remove dust bin and check for clogs.

➤ If the dust bin and filter areas and the hose areas are free of clogs, check the nozzle area.

➤ Check the clean out port.

➤ Return the vacuum cleaner to the upright position before plugging into an electrical outlet.

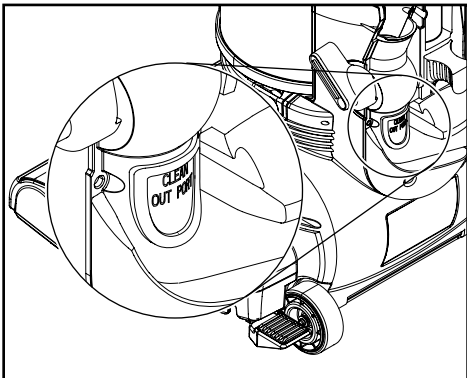
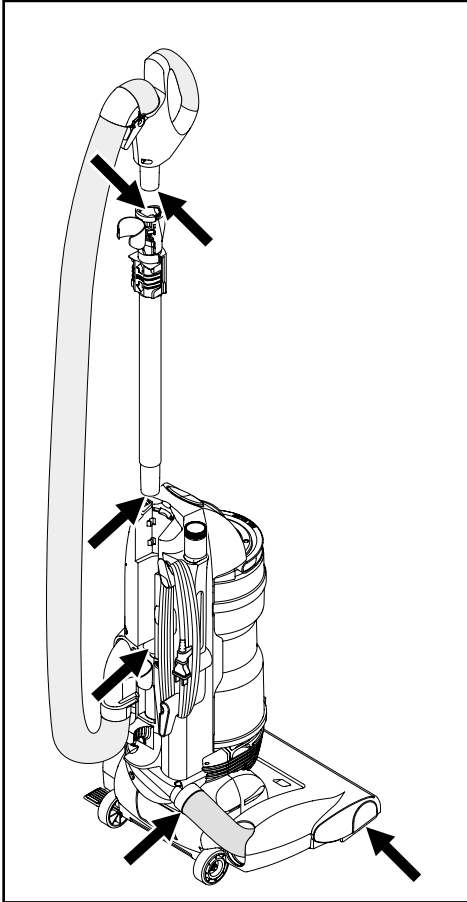

BEFORE REQUESTING SERVICE



WARNING Electrical Shock or Personal Injury Hazard

Disconnect the electrical supply before servicing or cleaning the vacuum cleaner. Failure to do so could result in electrical shock or personal injury from vacuum cleaner suddenly starting.

Review this chart to find do-it-yourself solutions for minor performance problems. Any service needed, other than those described in these Operating Instructions, should be performed by an authorized service representative.

PROBLEM	POSSIBLE CAUSE	POSSIBLE SOLUTION
Vacuum Cleaner won't run.	<ol style="list-style-type: none"> 1. Unplugged at wall outlet. 2. Tripped circuit breaker/blown fuse at household service panel. 3. Thermal protector tripped. 	<ol style="list-style-type: none"> 1. Plug in firmly, turn on vacuum cleaner. 2. Reset circuit breaker or replace fuse. 3. Unplug vacuum cleaner, allow to cool and thermal protector will reset itself.
Poor job of dirt pick up	<ol style="list-style-type: none"> 1. Full or clogged dust bin. 2. Worn agitator. 3. Clogged nozzle. 4. Clogged hose. 5. Hole in hose. 6. Broken belt 7. Motor protection system activated. 8. Dirty filters. 9. Floor/Tools Selector knob in wrong position. 	<ol style="list-style-type: none"> 1. Empty dust bin. 2. Take to your nearest Panasonic Service Center. 3. Check for clogs. 4. Check for clogs. 5. Take to your nearest Panasonic Service Center. 6. Replace belt. 7. Check for clogs. 8. Change primary filter and exhaust filter. 9. Check Floor/Tools selector knob position.
Light won't work.	<ol style="list-style-type: none"> 1. Burned out light bulb. 	<ol style="list-style-type: none"> 1. Change light bulb.
Agitator does not turn.	<ol style="list-style-type: none"> 1. Carpet/Bare floor selector in Bare Floor 2. Broken belt. 3. Tripped overload protector in nozzle. 	<ol style="list-style-type: none"> 1. Select CARPET position. 2. Replace belt. 3. Remove any items that may be caught or jammed, then reset. If vacuum cleaner starts and stops again, clean agitator and end caps, then reset.
Air flow restricted with attachment use. Sound changes.	<ol style="list-style-type: none"> 1. Attachment use restricts air flow. 2. New carpet fuzz clogged air path. 3. Floor/Tool Selector knob in wrong position. 	<ol style="list-style-type: none"> 1. See ATTACHMENTS. 2. See CLOG REMOVAL and clean hose. 3. Check Floor/Tool selector knob position.
Dirt Sensor will not work.	<ol style="list-style-type: none"> 1. Dirty optic cells. 	<ol style="list-style-type: none"> 1. See CLEANING OPTIC CELLS.
AEROBLAST lights stay lit during operation.	<ol style="list-style-type: none"> 1. Dust bin not installed properly. 	<ol style="list-style-type: none"> 1. Check dust bin installation.

WARRANTY

Panasonic Vacuum Cleaner Limited Warranty (United States)

Panasonic Consumer Electronics Company (collectively referred to as "the warrantor") will repair this product with new or refurbished parts free of charge, in the U.S.A. or Puerto Rico for one (1) year from the date of original purchase in the event of a defect in materials or workmanship.

This Limited Warranty Excludes both Labor and Parts for the following items which require normal replacement: Disposable Dust Bag, Filters, Belts, Light Bulbs, Agitator Brushes and Batteries (if supplied).

Carry-in or mail-in service in the U.S.A. can be obtained during the warranty period by contacting a Panasonic Services Company (PASC) Factory Servicenter listed in the Servicenter Directory. Or call, toll free, 1-800-211-PANA (7262) to locate a PASC Authorized Servicenter. Carry-in or mail-in service in Puerto Rico can be obtained during the warranty period by calling the local Panasonic Sales Company telephone number listed in the Servicenter Directory.

This warranty is extended only to the original purchaser. A purchase receipt or other proof of date of original purchase will be required before warranty performance is rendered.

This warranty only covers failures due to defects in materials and workmanship which occur during normal use and does not cover damages which occur in shipment, or failures which are caused by products not supplied by the warrantor, or failures which result from accident, misuse, abuse, neglect, mishandling, misapplication, faulty installation, improper operation or maintenance, alteration, modification, power line surge, improper voltage supply, lightning damage, commercial use such as hotel, office, restaurant or other business or rental use of the product, or service by anyone other than a PASC Authorized Servicenter, or damage that is attributable to acts of God.

LIMITS AND EXCLUSIONS:

There are no express warranties except as listed above.

THE WARRANTOR SHALL NOT BE LIABLE FOR INCIDENTAL OR CONSEQUENTIAL DAMAGES RESULTING FROM THE USE OF THIS PRODUCT, OR ARISING OUT OF ANY BREACH OF THIS WARRANTY. ALL EXPRESS AND IMPLIED WARRANTIES, INCLUDING THE WARRANTIES OF MERCHANTABILITY AND FITNESS FOR A PARTICULAR PURPOSE, ARE LIMITED TO THE APPLICABLE WARRANTY PERIOD SET FORTH ABOVE.

Some states do not allow the exclusion or limitation of incidental or consequential damages, or limitations on how long an implied warranty lasts, so the above exclusions or limitations may not apply to you.

This warranty gives you specific legal rights and you may also have other rights which vary from state to state. If a problem with this product develops during or after the warranty period, you may contact your dealer or Servicenter. If the problem is not handled to your satisfaction, then write to the Consumer Affairs Department at the listed address on the back cover.

WARRANTY

Panasonic Canada Inc.

PANASONIC PRODUCT - LIMITED WARRANTY

Panasonic Canada Inc. warrants this product to be free from defects in material and workmanship and agrees to remedy any such defect for a period as stated below from the date of original purchase.

Vacuum Cleaner - One (1) year, parts and labour

LIMITATIONS AND EXCLUSIONS

This warranty does not apply to products purchased outside Canada or to any product which has been improperly installed, subjected to usage for which the product was not designed, misused or abused, damaged during shipping, or which has been altered or repaired in any way that affects the reliability or detracts from the performance, nor does it cover any product which is used commercially. Parts such as disposable dust bags, filters, belts, light bulbs and agitator brushes are also excluded from coverage under this warranty. A purchase receipt or other proof of date of original purchase is required before warranty service is performed.

THIS EXPRESS, LIMITED WARRANTY IS IN LIEU OF ALL OTHER WARRANTIES, EXPRESS OR IMPLIED, INCLUDING ANY IMPLIED WARRANTIES OF MERCHANTABILITY AND FITNESS FOR A PARTICULAR PURPOSE. IN NO EVENT WILL PANASONIC CANADA INC. BE LIABLE FOR ANY SPECIAL, INDIRECT OR CONSEQUENTIAL DAMAGES.

In certain instances, some jurisdictions do not allow the exclusion or limitation of incidental or consequential damages, or the exclusion of implied warranties, so the above limitations and exclusions may not be applicable.

WARRANTY SERVICE

FOR PRODUCT OPERATION ASSISTANCE, please contact:

Our Customer Care Centre:	Telephone #:	(905) 624-5505
	1-800 #:	1-800-561-5505
	Fax #:	(905) 238-2360
	Email link:	"Contact Us" on www.panasonic.ca

FOR PRODUCT REPAIRS, please locate your nearest Authorized Servicentre at www.panasonic.ca :

Link : "Servicentres™ locator" under "Customer support"

IF YOU SHIP THE PRODUCT TO A SERVICENTRE

Carefully pack and send prepaid, adequately insured and preferably in the original carton.
Include details of the defect claimed, and proof of date of original purchase.

Ref: VACwar Eng_Apr06

WHAT TO DO WHEN SERVICE IS NEEDED

If your Panasonic Vacuum Cleaner needs service, look in the yellow pages of the telephone book under HOME APPLIANCE SERVICE for your nearest Panasonic Services Company ("PASC") Factory Servicenter, or PASC authorized Servicenter, or call, 1-800-211-PANA (7262) toll free to find a convenient servicenter. **DO NOT send the product to the Executive or Regional Sales offices. They are NOT equipped to make repairs.**

If you ship the product

Carefully pack and send it prepaid, adequately insured and preferably in the original carton. Attach a postage-paid letter to the outside of the carton, which contains a description of your complaint. **DO NOT send the product to the Executive or Regional Sales Offices. They are NOT equipped to make repairs.**

**PANASONIC CONSUMER ELECTRONICS COMPANY
DIVISION OF PANASONIC CORPORATION OF NORTH AMERICA**

One Panasonic Way
Secaucus, New Jersey 07094
World Wide Web Address
<http://www.panasonic.com>

What to do when service is needed Service après-vente (Canada)

WARRANTY SERVICE

For product operation and information assistance, please contact your Dealer or our Customer Care Centre at:

Telephone #: (905) 624-5505

Fax #: (905) 238-2360

Web: www.panasonic.ca

For product repairs, please contact one of the following:

- Your Dealer who will inform you of an authorized Servicentre nearest you.
- Our Customer Care Centre at (905) 624-5505 or www.panasonic.ca

RÉPARATION SOUS GARANTIE

Pour de l'aide sur le fonctionnement de l'appareil ou pour toute demande d'information, veuillez contacter votre détaillant ou notre service à la clientèle au :

N° de téléphone : (905) 624-5505 N° de télécopieur : (905) 238-2360 Site Internet : www.panasonic.ca

Pour la réparation des appareils, veuillez consulter :

- votre détaillant, lequel pourra vous renseigner sur le centre de service agréé le plus près de votre domicile ;
- notre service à la clientèle au (905) 624-5505 ou www.panasonic.ca;
- un de nos centres de service indiqué sur la page de garantie.

Quando necesita servicio

Si su aspiradora Panasonic necesita servicio, busque el Centro de Servicio Panasonic o un Centro de Servicio PASC autorizado más cercano bajo "Servicio de Electrodomésticos" en las páginas amarillas de la guía de teléfonos o llame gratis al 1-800-211-PANA (7262) para encontrar un centro de servicio conveniente. No mande el producto a las Executive o Regional Sales Offices. No están equipadas para arreglar estos productos.

Si manda el producto

Empaquete con cuidado en el cartón original si posible y mándelo prepagado y con seguro suficiente. Ponga una carta con sellos en la que describe su problema con el producto en el exterior del cartón. No mande el producto a las Executive o Regional Sales Offices. No están equipadas para arreglar estos productos.

**PANAMEX COMPANY
DIVISION OF PANASONIC CORPORATION OF NORTH AMERICA**

One Panasonic Way
Secaucus, New Jersey 07094
World Wide Web Address
<http://www.panasonic.com>

AC01ZCXWZ000
C01ZCXW20000

Printed in Mexico
Imprimé au Mexique
Impreso en Mexico