

# EXPLODED VIEW (NOZZLE HOUSING)... **A** BLOCK

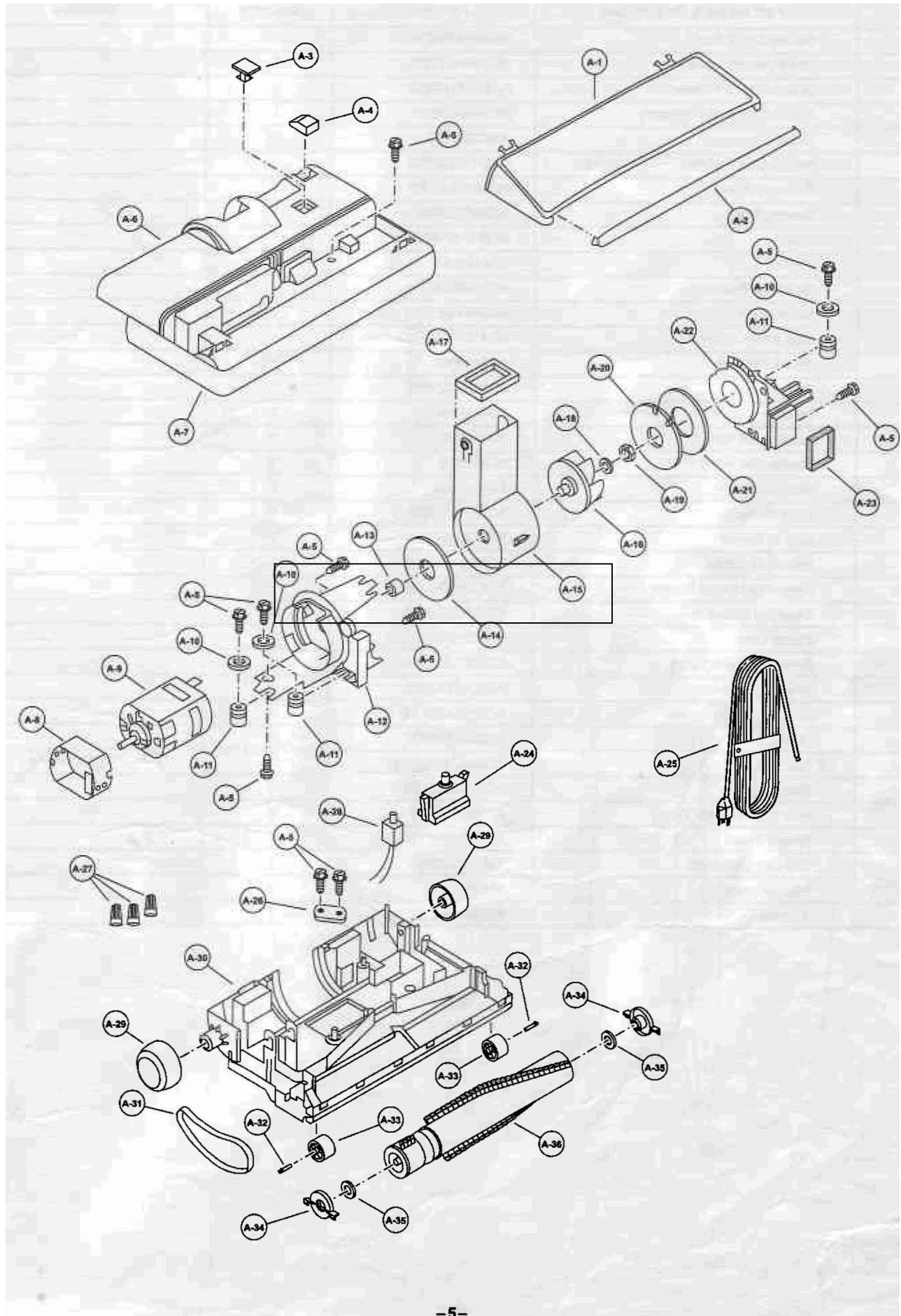

# PARTS LIST (NOZZLE HOUSING)... [A] BLOCK

Ref. No.	Part Name & Description	Part No.	Quantity	Remarks
A • 1	Nozzle Cover. Front	AC24HAPMZYU2		
A - 2	Insert (Nozzle Cover)	AC21HHJZY02		
A - 3	Button (ON/OFF Switch)	AC05EHJZV07		
A - 4	Button (Overload Protector)	AC64NHJZV07		
A - 5	Screw	AMC681-297	10	
A - 6	Nozzle Cover, Main	AC01AHJZY02		
A - 7	Furniture Guard	AC10AHJZV07		
A - 8	Shroud, Motor	AC58FTCZ00		
A - 9	Motor	AC01FAPMZ000		
A - 10	Washer	AC4149593		
A - 11	Grommet, Rubber	AC4149498		
A - 12	Motor Mount	AC08FHJZU00		
A - 13	Seal (Motor Shaft)	AC4153709		
A - 14	Seal A (Swivel)	AC4149587		
A - 15	Swivel	AC25QHJZV07		
A - 16	Impeller	AC4149440		
A - 17	Packing (Air Outlet)	AC4149591		
A - 18	Washer (Impeller)	AC665705		
A - 19	Nut (Impeller)	AC4149448		
A - 20	Plate (Swivel)	AC56FHJZV07		
A - 21	Seal B, Swivel	AC4149594		
A - 22	Elbow, Air Intake	AC15HHJ1U00		
A - 23	Gasket (Air Intake Elbow)	AC51LHJZ000		
A - 24	Overload Protector	AC76FHJZ000		
A - 25	Power Cord	AC94EAPMZU00		
A - 26	Retainer (Power Cord)	AC62ETEZU01		
A - 27	Wire Connector	AMC-1CTCE23		
A - 28	ON/OFF Switch	AC01EHJZ000		
A - 29	Wheel, Rear	AC01CHJZV07		
A - 30	Nozzle Base	AC03AAPMZU00		
A - 31	Belt	AC28SHJZ000		
A - 32	Axle Shaft (Wheel, Front)	AC16CNXZ00	2	
A - 33	Wheel, Front	AC90QNGZV04	2	
A - 34	End Cap (Agitator)	AMC743-395	2	
A - 35	Washer (Agitator)	AMC681-424	2	
A - 36	Agitator	AC84RAPMZ000	1	

# EXPLODED VIEW (HANDLE, BAG COVER, AND DUST BAG)... **B** BLOCK

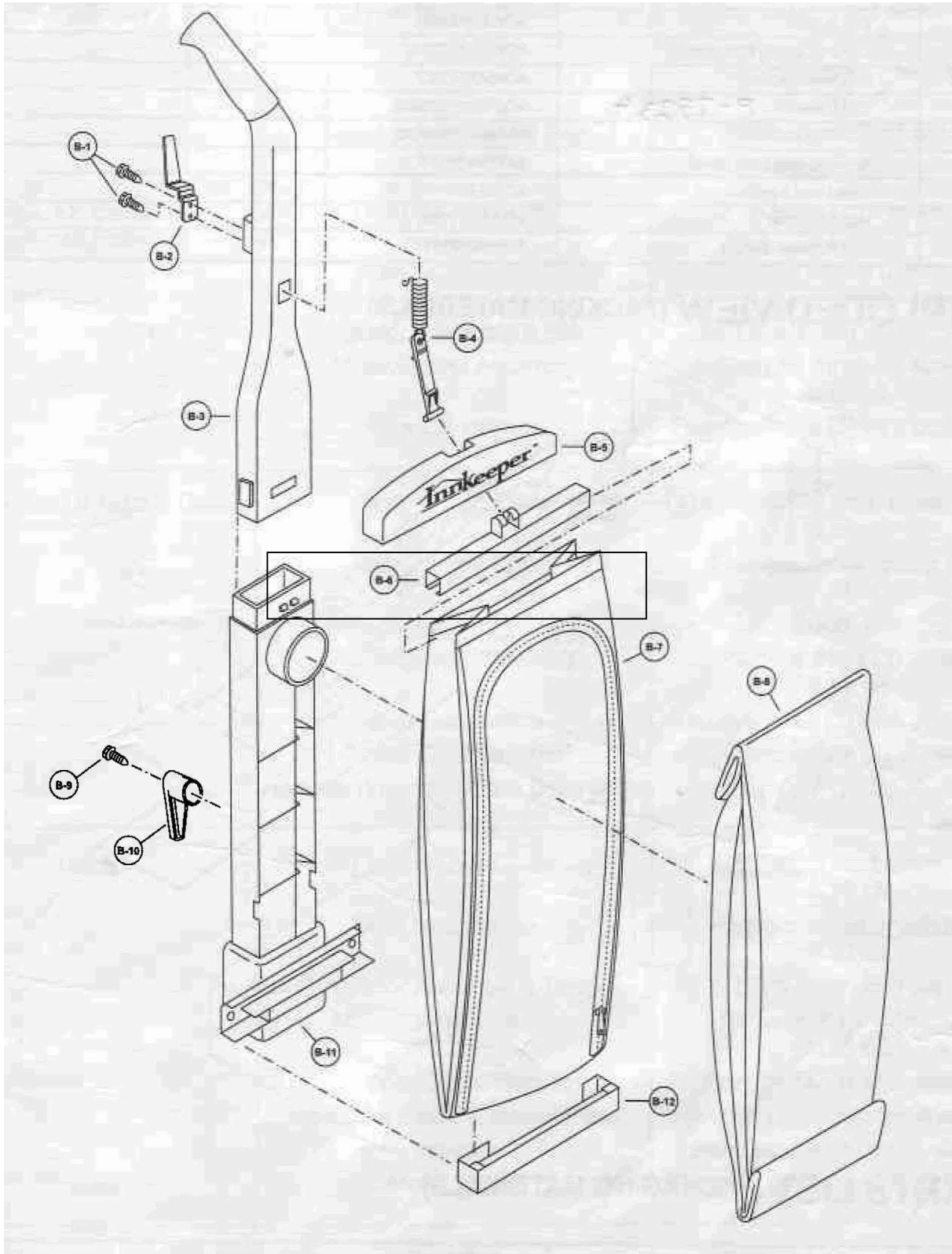

# PARTS LIST (HANDLE, BAG COVER, AND DUST BAG)... **B** BLOCK

Ref. No.	Part Name & Description	Part No.	Quantity	Remarks
B - 1	Screw (Upper Cord Hook)	AC68AZAZ00	2	
B - 2	Cord Hook, Upper	AC53ETEZ00	1	
B - 3	Handle, Upper	AC50BAPMZV07	1	
B - 4	Bag Support	AC11KZFZV07	1	
B - 5	Cover (Top Bag Retainer)	AC64KAPMZVU7	1	
B • 6	Bag Retainer, Top	AC53KTFZVU7	1	
B - 7	Bag Cover p - *] ^ ^ 4	AC01KAPMZU00	1	
B - 8	Dust Bag (U-9)	AC16KAPMZ0U0	1	
B - 9	Screw (Lower Cord Hook)	AXTN4+16BFY		
B - 10	Cord Hook, Lower	AC54EZFZV07	1	
B - 11	Handle, Lower	AC52BTF2V07	1	
B • 12	Bag Retainer, Bottom	AC65KZFZV07	1	

## EXPLODED VIEW (PACKING MATERIALS)

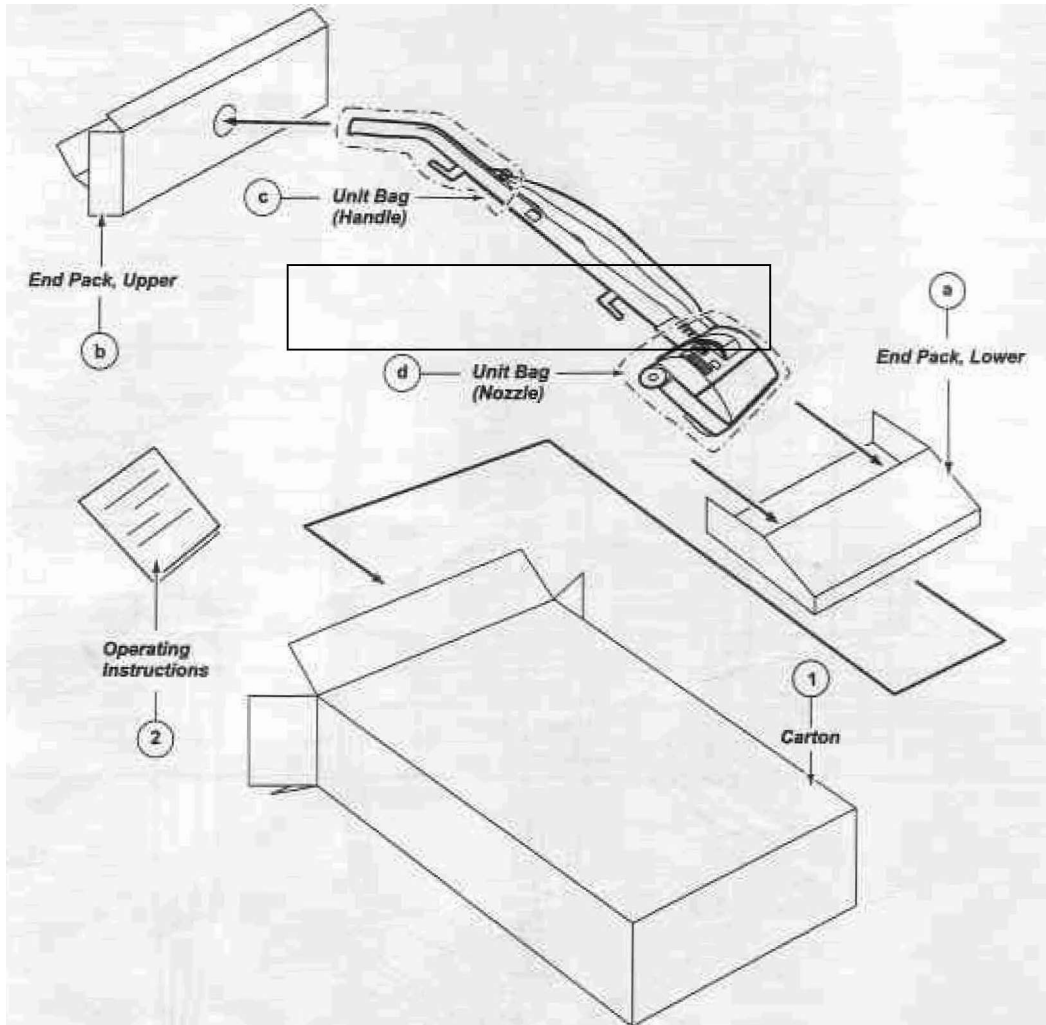

## PARTS LIST (PACKAGING MATERIALS)

Ref. No.	Part Name & Description	Part No.	Quantity	Remarks
1	Packaging Assembly	AC61ZAPMZ00	1	Includes 1 and items a-d
2	Operating Instructions	AC01ZAPMZ0U	1	