

This Owner's Manual is provided and hosted by [Appliance Factory Parts](#).

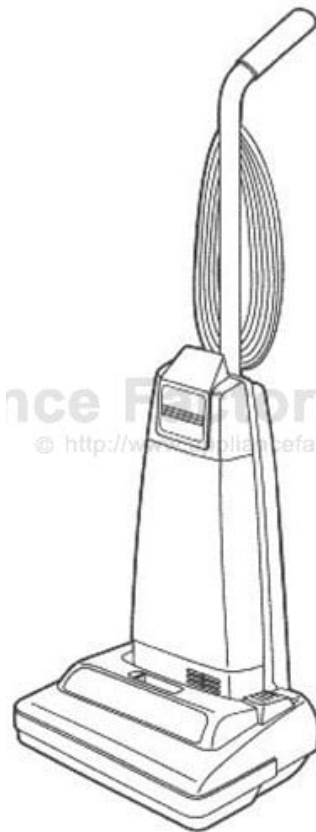

# PANASONIC MC-V210 Owner's Manual

[Shop genuine replacement parts for PANASONIC  
MC-V210](#)



[Find Your PANASONIC Vacuum Cleaner Parts - Select From 605 Models](#)

----- Manual continues below -----

# Panasonic®

COMMERCIAL VACUUM CLEANER  
*Commercial aspiradora*

## MC-V210

Operating Instructions  
*Instrucciones de operación*

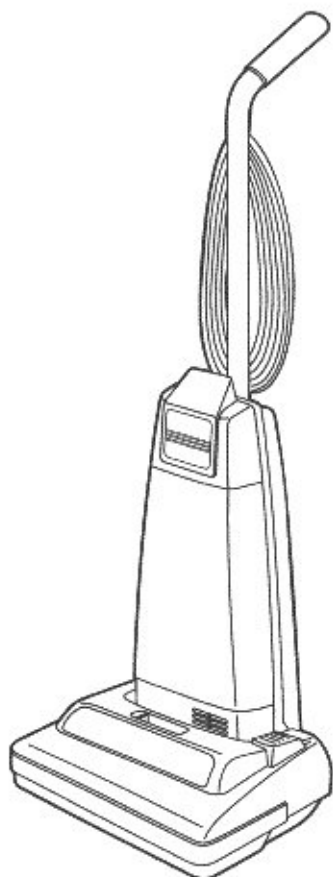

**Before operating your vacuum cleaner, please read these instructions completely.**

*Antes de usar su aspiradora, lea completamente estas instrucciones por favor.*

C01ZBAW00U00

# CONSUMER INFORMATION

Please read **IMPORTANT SAFETY INSTRUCTIONS** on page 5 before use. Read and understand all instructions.

## TO OUR VALUED CUSTOMER

We are very pleased to welcome you to the Panasonic family of products. Thank you for purchasing this product. Our intent is that you become one of our many satisfied customers.

**Proper assembly and safe use of your vacuum cleaner are your responsibilities. Your vacuum cleaner is intended for commercial use. The cleaner should be stored in a dry, indoor area. Read the Operating Instructions carefully for important use and safety information.**

**Special care is required when vacuuming certain types of carpet or floor covering. Always check the carpet or floor covering manufacturer's recommended cleaning instructions before vacuuming.**

## PLEASE PAY CLOSE ATTENTION TO ALL WARNING AND CAUTION STATEMENTS.



**WARNING** statements are designed to alert you to the possibility of personal injury, loss of human life, and/or damage to the vacuum cleaner and/or personal property if the instructions given are not followed.



**CAUTION** statements are designed to alert you to the possibility of damage to the vacuum cleaner and/or personal property if the instructions given are not followed.



### TO AVOID ELECTRICAL SHOCK

Never vacuum damp or wet surfaces or liquids.  
DO NOT store machine outdoors.  
Replace worn or frayed power cord immediately.  
Unplug from outlet when not in use and before servicing.

### TO AVOID ACCIDENTS

Except for hand-held cleaners, keep machine on floor - not chairs, tables, steps, stairs, etc.  
Store machine promptly after each use to prevent accidents such as tripping over power cord or machine.  
Use machine and accessories only in a manner intended by the manufacturer.  
The use of an extension cord is not recommended.

©2000 Matsushita Electric Corporation of America, Ltd. All rights reserved.

## **TABLE OF CONTENTS / *Tabla de contenido***

<b>CONSUMER INFORMATION / Información para consumidor</b> .....	2-3
<b>IMPORTANT SAFETY INSTRUCTIONS</b> <i>Instrucciones importantes de seguridad</i> .....	5-6
<b>GROUNDING INSTRUCTIONS</b> <i>Instrucciones para hacer conexión a tierra</i> .....	7-8
<b>PARTS IDENTIFICATION / Identificación de piezas</b> .....	9
<b>ASSEMBLY / Montaje</b> .....	10
<b>Attaching Handle / Colocación del mango</b> .....	10
<b>FEATURES / Características</b> .....	11
<b>Carpet Height Selector / Selector para el nivel de alfombra</b> .....	11
<b>Edge Cleaning / Limpieza para orillas</b> .....	11
<b>Motor Protector / Protector de motor</b> .....	11
<b>TO OPERATE CLEANER / Para operar la aspiradora</b> .....	12
<b>ON-OFF Switch / Control ON-OFF</b> .....	12
<b>Handle Adjustments / Ajustes del mango</b> .....	12
<b>Using Tools (Optional Accessories)</b> <i>Uso de herramientas (accesorios opcionales)</i> .....	13
<b>ROUTINE CARE OF CLEANER / Cuidado de rutina de la aspiradora</b> .....	14
<b>Cleaning Secondary Foam Filter</b> <i>Limpieza del filtro secundario de goma espuma</i> .....	14
<b>Changing Dust Bag / Cambio de la bolsa para polvo</b> .....	15
<b>Removing and Installing Lower Plate</b> <i>Cambiar y insertar de la base inferior</i> .....	16
<b>Replacing Belt / Cambio de la correa</b> .....	17
<b>Cleaning Agitator / Limpieza del agitador</b> .....	17
<b>Replacing Brushes / Cambiar los cepillos</b> .....	18
<b>Cleaning Exterior and Tools / Limpieza del exterior y de los heramientas</b> .....	19
<b>Removing Clogs / Quitar de los residuos de basura en los conductos</b> .....	19
<b>BEFORE REQUESTING SERVICE / Antes de pedir servicio</b> .....	20-21
<b>WARRANTY / Garantía</b> .....	22-23
<b>WHAT TO DO WHEN SERVICE IS NEEDED / Cuando necesita servicio</b> .....	24

# IMPORTANT SAFETY INSTRUCTIONS

When using vacuum cleaner, basic precautions should always be followed, including the following:

## READ ALL INSTRUCTIONS BEFORE USING THIS VACUUM CLEANER



## WARNING

To reduce the risk of fire, electrical shock, injury:

1. **DO NOT** leave vacuum cleaner when plugged in. Unplug from outlet when not in use and before servicing.
2. To reduce the risk of fire, electric shock - **DO NOT** use outdoors or on wet surfaces.
3. **DO NOT** allow to be used as a toy. Close attention is necessary when used by or near children.
4. Use only as described in this manual. Use only manufacturer's recommended tools.
5. **DO NOT** use with damaged cord or plug. If vacuum cleaner is not working as it should, has been dropped, damaged, left outdoors, or dropped into water, return it to an authorized Panasonic Servicentre.
6. **DO NOT** pull or carry by cord, use cord as a handle, close door on cord, or pull cord around sharp edges or corners. **DO NOT** run vacuum cleaner over cord. Keep cord away from heated surfaces.
7. **DO NOT** unplug by pulling on cord. To unplug, grasp the plug, not the cord.
8. **DO NOT** handle plug or vacuum cleaner with wet hands.
9. **DO NOT** put any objects into openings. **DO NOT** use with any opening blocked; keep free of dust, lint, hair, and anything that may reduce air flow.
10. Keep hair, loose clothing, fingers, and all parts of body away from openings and moving parts.
11. **DO NOT** pick up anything that is burning or smoking, such as cigarettes, matches, or hot ashes.
12. **DO NOT** use without dust bag and/or filters in place.
13. Turn off all controls before unplugging.
14. Use extra care when cleaning on stairs.
15. **DO NOT** use cleaner to pick up flammable or combustible liquids such as gasoline or use in areas where they may be present.
16. Connect to a properly grounded outlet only. See "Grounding Instructions"

## SAVE THESE INSTRUCTIONS

# GROUNDING INSTRUCTIONS

This vacuum cleaner must be grounded. If it should malfunction or breakdown, grounding provides a path of least resistance for electric current to reduce the risk of electric shock. This vacuum cleaner is equipped with a cord having an equipment-grounding conductor and grounding plug. The plug must be plugged into an appropriate outlet that is properly installed and grounded in accordance with all local codes and ordinances.

## **DANGER**

Improper connection of the equipment-grounding conductor can result in a risk of electric shock. Check with a qualified electrician or service person if you are in doubt as to whether the outlet is properly grounded. Do not modify the plug provided with the vacuum cleaner – if it will not fit the outlet, have a proper outlet installed by a qualified electrician.

This vacuum cleaner is for use on a nominal 120-volt circuit, and has a grounding plug that looks like the plug illustrated in sketch A in the following Figure. Make sure that this vacuum cleaner is connected to an outlet having the same configuration as the plug.

No adapter should be used with this vacuum cleaner.

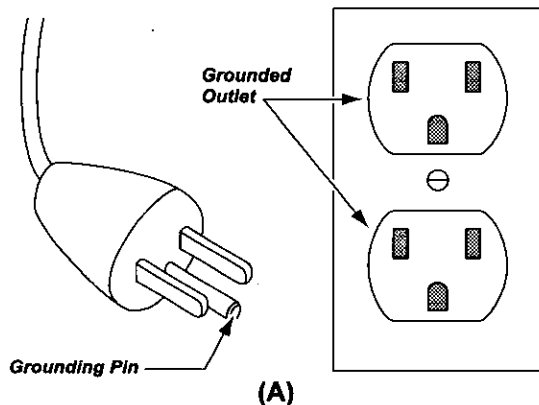

**Note:** Before you plug in your Panasonic vacuum cleaner, make sure that the voltage indicated on the rating plate located at the back of the vacuum cleaner is the same as your local supply.

# ASSEMBLY / Montaje

## Attaching Handle / Colocación del mango

1)

➤ **DO NOT plug in until assembly is complete**  
*No enchufe hasta que el montaje esté completo*

➤ **Remove handle screw**  
*Quite el tornillo del mango*

➤ **Insert handle with cord hook to the back of the cleaner**  
*Meta el mango con el sujetador del cordón en la parte posterior de la aspiradora*

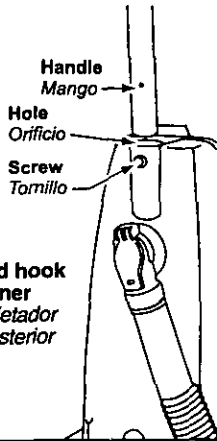

2)

➤ **Insert screw**  
*Instale el tornillo*

➤ **Tighten screw**  
*Apriete el tornillo*

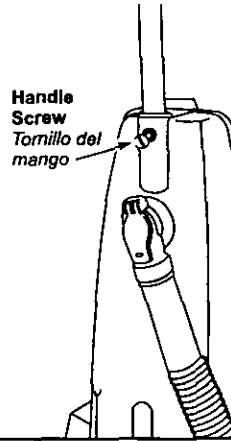

3)

➤ **Push power cord into cord clip in back of handle**  
*Empuje el cordón eléctrico hacia el soporte del cordón en la parte posterior del mango*

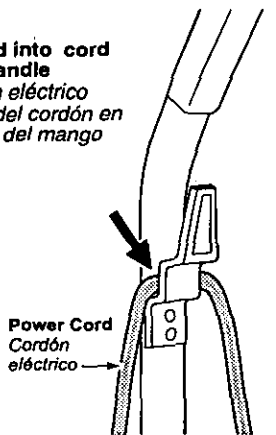

4)

➤ **Wrap power cord around cord hook**  
*Envuelva el cordón eléctrico alrededor del sujetador del cordón*

➤ **Secure retainer (plug head) to power cord**  
*Asegure la clavija en el cordón eléctrico*

➤ **Place cord wrap around bottom loop of power cord**  
*Coloque el gancho del cordón alrededor del lazo inferior del cordón*

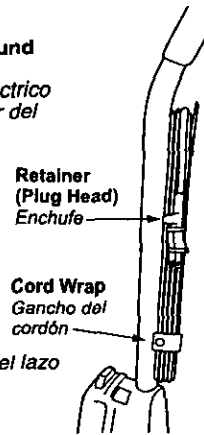

## FEATURES / Características

### Carpet Height Selector / Selector para el nivel de alfombra

- **Allows for adjustments to efficiently and safely clean different types of floors**  
*Esta característica es para los ajustes para la limpieza eficiente y segura de muchos tipos de suelos*
- **To select pile height setting, first turn off vacuum**  
*Para seleccionar la posición de la altitud de la pelusa, apague la aspiradora primero*
- **Tilt vacuum back and slide adjustment lever to desired setting**  
*Incline la aspiradora hacia atrás y deslice el control de ajustes a la posición deseada*

#### SUGGESTED CARPET HEIGHT SETTINGS:

*Las posiciones sugeridas para el nivel de la alfombra:*

- ||||| **shag carpet, long pile, plush, scatter rugs**  
*pelo áspero y lanudo, pelo largo, felpa, alfombras o tapetes irregulares*
- |||| **medium to long pile**  
*pelo mediano o poco largo*
- ||| **short to medium pile**  
*pelo corto o mediano*
- **very low pile**  
*pelo muy corto*

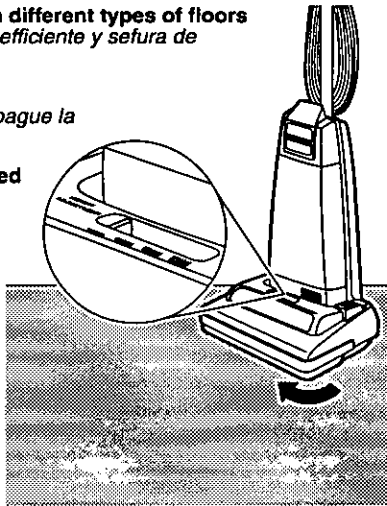

### Edge Cleaning / Limpieza para orillas

- **Edge cleaning feature provides for improved cleaning of carpets near walls and furniture**  
*Use la característica de limpieza para orillas para aspirar con facilidad cerca de las paredes y los muebles*

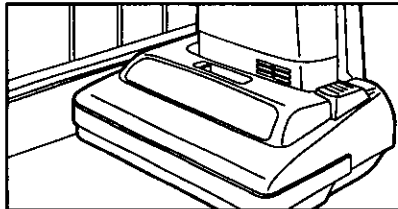

### Motor Protector / Protector de motor

- **Automatically opens to provide cooling air to the motor when a clog occurs or when dust bag needs changing**  
*Se abre automáticamente para proveer el aire fresco al motor cuando hay unos residuos o cuando es necesario cambiar la bolsa de polvo*
- **Motor protector may open when using tools**  
*Es posible que el protector del motor se abra cuando se usan las herramientas*
- **If motor protector opens, the vacuum will make a slightly different sound**  
*Si se abre el protector del motor, la aspiradora hará un sonido poquito diferente*

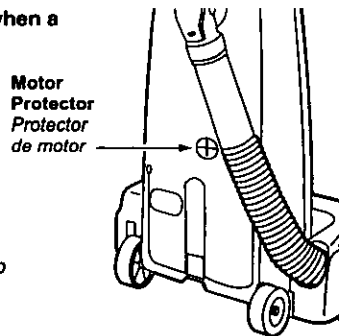

## TO OPERATE CLEANER

*Para operar la aspiradora*

### ON-OFF Switch / Control ON-OFF

- **Ensure ON-OFF switch is OFF**  
*Asegúrese de que el control ON-OFF esté en la posición OFF*
- **Plug the power cord into 120V outlet**  
*Enchufe el cordón eléctrico en una toma de pared de 120 V*
- **ON position turns vacuum on**  
*La posición ON enciende la aspiradora*
- **OFF position turns vacuum off**  
*La posición OFF apaga la aspiradora*

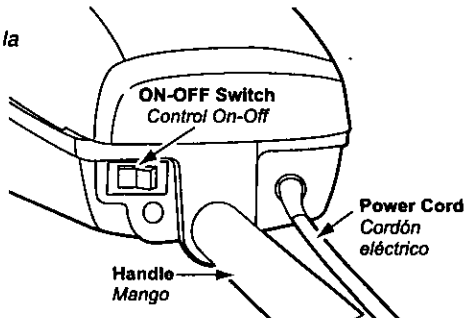

### Handle Adjustments / Ajustes del mango

- 1)
- **Step on handle release pedal to change handle position**  
*Pise en el pedal de liberación del mango para cambiar la posición del mango*

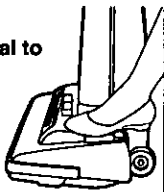

- 2)
- **Move vacuum to upright position for storage and tool use**  
*Mueva la aspiradora a la posición vertical para el almacenaje y el uso de las herramientas*

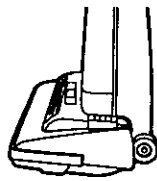

- 3)
- **Move vacuum to middle position for normal use**  
*Mueva la aspiradora a la posición mediana para el uso normal*

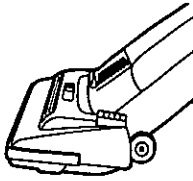

- 4)
- **Use low position for cleaning under furniture**  
*La posición baja para limpiar debajo de los muebles*

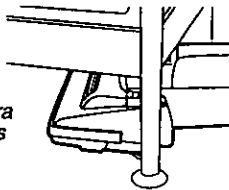

## Using Tools (Optional Accessories)

### *Uso de herramientas (accesorios opcionales)*

The tools for this unit are optional. For information on how to obtain these items consult the Servicer list that is packaged with this manual or contact any authorized Panasonic vacuum cleaner dealer.

*Los accesorios para esta unidad son opcionales. Para información para comprar estos accesorios, consulte la lista de los Centros de Servicio que está incluida con este manual o comuníquese con una tienda autorizada de las aspiradoras Panasonic.*

#### DELUXE TOOL KIT (MC-880AD) / Juego de accesorios de lujo (MC-880AD)

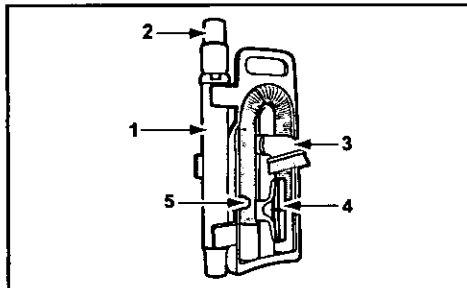

1. **Telescoping Wand**  
*Tubo telescópico*
2. **Crevice Tool**  
*Herramienta para hendiduras*
3. **Dusting Brush**  
*Cepillo para sacudir*
4. **Upholstery Tool**  
*Herramienta para tapices*
5. **Hose Assembly**  
*Montaje de manguera*

### **!** CAUTION / CUIDADO

If tools are used, and vacuum is left in upright position, carpet damage could occur  
*Si se usan herramientas, y la aspiradora se deja en posición vertical, puede haber daño a la alfombra*

Agitator rotates when using tools, use care to ensure that nothing comes into contact with agitator  
*El agitador gira cuando se utilizan las herramientas, tenga cuidado que nada toque el agitador*

- See **TOOLS, Optional Accessories** to identify tools  
*Véase ACCESORIOS, Accesorios Opcionales para identificar la herramienta*
- To connect hose, lift suction inlet cover on back of vacuum and insert tapered hose end and twist slightly  
*Para conectar la manguera, levante la cubierta de abertura de aspiración en la parte posterior de la aspiradora y meta el extremo estrecho de la manguera y gire un poquito*
- Hose can be used as is, or additional wand and/or tools can be connected, by pushing and giving a slight twist  
*Se puede usar la manguera solo, o tubo opcional y/o se puede conectar las herramientas, empujándolas y girándolas un poquito*
- The dusting brush and upholstery tool can be attached to hose, wand, or crevice tool  
*Se puede conectar el cepillo de polvo y el herramienta para tapices con la manguera, el tubo o la herramienta de hendiduras*
- All other tools may be connected to the hose or wand  
*Se pueden conectar todas las otras herramientas con la manguera o el tubo*

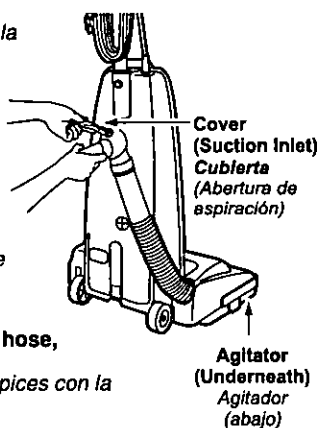

## ROUTINE CARE OF CLEANER

### *Cuidado de rutina de la aspiradora*

Performing the following tasks will keep your new Panasonic vacuum cleaner operating at peak performance levels and will ensure these high levels for years to come. Check the **BEFORE REQUESTING SERVICE** section in this manual for recommendations on performing some of these tasks to help solve various problems that may occur.

*Siguiendo las instrucciones dadas, se nueva aspiradora Panasonic funcionará al nivel máximo y continuará funcionando por muchos años en el futuro. Lea la sección "Antes de pedir servicio" en este manual para las recomendaciones para arreglar unos problemas que puedan ocurrir.*

## Cleaning Secondary Foam Filter

### *Limpieza del segundo filtro de goma espuma*



#### CAUTION / CUIDADO

To prevent damage to vacuum cleaner, the secondary foam filter must be kept clean  
*Para prevenir daño a la aspiradora, el segundo filtro de goma espuma debe mantenerse limpio*

> **The secondary foam filter protects the motor**  
*El segundo filtro de goma espuma protege el motor*

> **Check filter when installing a new dust bag**  
*Al instalar una nueva bolsa de polvo revise el filtro*

> **If dirty, pull filter from bottom of dust compartment and clean by rinsing in water**  
*Si está sucio, tire del filtro del fondo del compartimento de polvo y límpielo enjuagando con agua*

> **When dry, slide filter back into place**  
*Cuando esté seco deslice el filtro a su lugar*

> **Ensure filter is fully inserted under plastic rib projections**  
*Asegúrese de que el filtro está instalado debajo de las lengüetas plásticas*

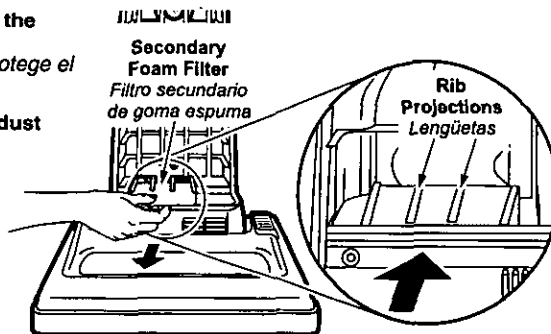



# Changing Dust Bag

## *Cambio de la bolsa para polvo*

Always operate vacuum with genuine Panasonic Type U3 Standard or U6 Electrostatic dust bags installed. Panasonic dust bags may be purchased through any authorized Panasonic dealer or ordered from service company. An optional cloth bag is available.

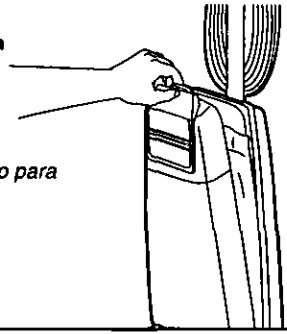
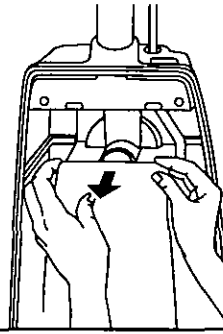
*Siempre opere la aspiradora con las bolsas Panasonic Type U3 Standard U6 Electrostatic instaladas. Se puede comprar las bolsas de polvo en cualquier vendedor autorizado Panasonic o mandar de una compañía de servicio. Se puede condeguir una bolsa opcional de tela.*

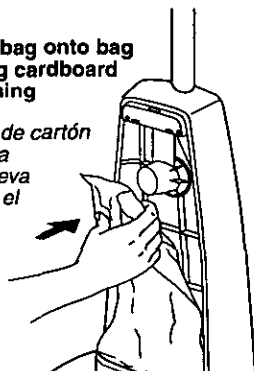
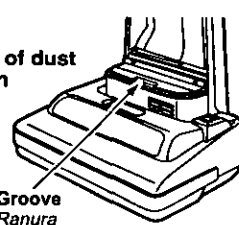
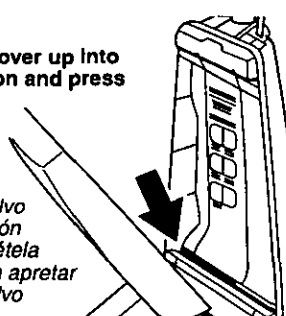
<p>1) ➤ Pull outward on dust cover grip to remove the dust cover <i>Empuje hacia afuera en la cubierta de polvo para quitarla</i></p> 	<p>2) ➤ Remove dust bag by grasping cardboard portion and pulling out <i>Agarre la parte de cartón de la bolsa y empuje hacia afuera para quitar la bolsa de polvo</i></p> 
<p>3) ➤ Spread out new dust bag, taking care not to tear bag <i>Extienda la nueva bolsa de polvo teniendo cuidado de no romper la bolsa</i></p> 	<p>4) ➤ Attach new dust bag onto bag holder by holding cardboard portion and pushing back <i>Teniendo la parte de cartón y empujando hacia atrás instale la nueva bolsa de polvo en el soporte para la bolsa</i></p> 
<p>5) ➤ Reinsert tab on end of dust cover into groove on dust compartment to allow cover to rotate closed <i>Reinstale la lengüeta en el extremo de la cubierta de polvo en la ranura en el compartimento de polvo para que la cubierta ruede hasta la posición cerrada</i></p> 	<p>6) ➤ Rotate dust cover up into closed position and press into place without pinching dust bag <i>Ruede la cubierta de polvo hasta la posición cerrada y aprétela en su lugar sin apretar la bolsa de polvo</i></p> 

# Removing and Installing Lower Plate

## *Cambiar y insertar de la base inferior*



### **WARNING / AVERTENCIA**

**Before servicing any parts, disconnect vacuum from electrical outlet**  
*Desenchufe la aspiradora de la toma de pared antes de hacerles servicio a las piezas*

- **Always place paper under nozzle anytime lower plate is removed to protect floor**  
*Siempre coloque un papel debajo de la boquilla para proteger el suelo cada vez se quita la base inferior*
- **Place handle in upright position and turn vacuum over to expose lower plate**  
*Coloque el mango en la posición vertical y vuelque la aspiradora para exponer la base inferior*
- **Release lower plate by pressing two (2) latches and two (2) locking tabs inward as shown**  
*Para liberar la placa inferior, apriete hacia adentro los dos (2) pestillos y las dos (2) lengüetas de cierre como se muestra*
- **Remove lower plate and remove any residue that may exist in belt area**  
*Quite la base inferior y quite los residuos que exista en el área de la correa*
- **Reinstall lower plate by hooking front end of lower plate into slots on front of nozzle housing**  
*Para reinstalar la base inferior, enganche el extremo delantero de la base inferior en las ranuras en el montaje delantero de la boquilla*
- **Press lower plate until locking tabs snap into place then push two (2) latches outward**  
*Apriete la placa inferior hasta que las lengüetas de cierre estén bien instaladas y luego empuje hacia afuera los dos (2) pestillos*

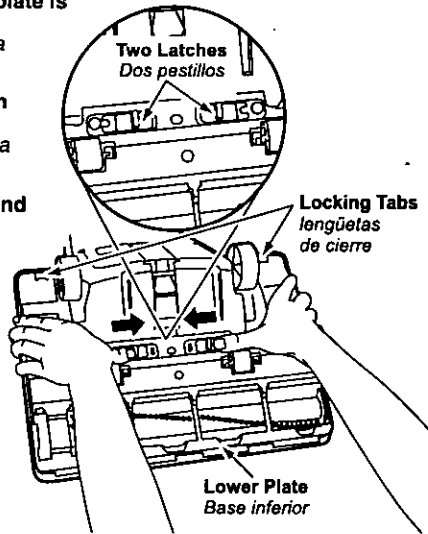

## Replacing Belt / Cambio de la correa

- **Replace belt whenever a burning rubber smell caused by excessive slippage occurs**  
*Cambie la correa cuando ocurra un olor de goma que quema causado por un patinaje excesivo*
- **Remove lower plate**  
*Quite la base inferior*
- **Remove agitator by carefully lifting out**  
*Al levantar con cuidado quite el agitador*
- **Remove worn or broken belt**  
*Quite la correa gastada o rota*
- **Loop new belt (Panasonic Type UB8 only) around motor shaft and brush pulley; see illustration for correct belt routing**  
*Envuelva la correa nueva (Panasonic Type UB8 solamente) en el eje del motor y la polea de cepillo, véase el diagrama para envolver la correa*
- **Clean agitator and replace two (2) end caps**  
*Limpie el agitador y cambie las dos (2) tapas del extremo*
- **Reinstall agitator back into nozzle housing grooves**  
*Reinstale el agitador en las ranuras del compartimento de la boquilla*
- **After reinstalling the agitator, turn it by hand to make sure that belt is not twisted or pinched and that all rotating parts turn freely**  
*Después de instalar el agitador, ruéde a mano para que asegure que la correa no esté torcida ni apretada y que rueden libremente todas las piezas rodantes*
- **Reinstall lower plate**  
*Reemplace la base inferior*

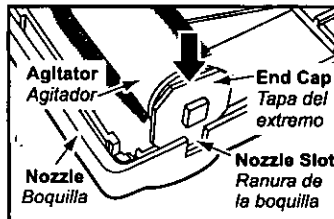
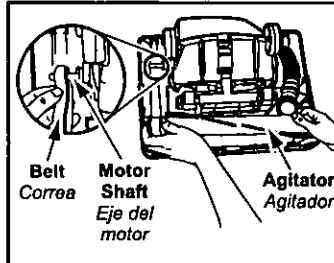
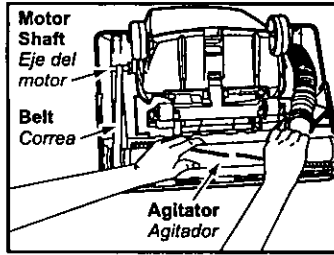

## Cleaning Agitator / Limpieza del agitador

- **Clean agitator after every five uses and every time the belt is replaced**  
*Limpie el agitador después de cada cinco utilizaciones y cada vez que se cambia la correa -*
- **Remove lower plate**  
*Quite la base inferior*
- **Cut off any carpet pile and lint entangled around agitator with a pair of scissors**  
*Corte con unas tijeras el pelo de alfombra y la pelusa envueltos en el agitador*
- **Remove agitator**  
*Quite el agitador*
- **Remove any string or debris located on the end caps or agitator shaft**  
*Quite los hilos o los residuos ubicados en los tapas del extremo, en las arandelas o en el eje del agitador*
- **Reinstall agitator and lower plate**  
*Reemplace el agitador y la base inferior*

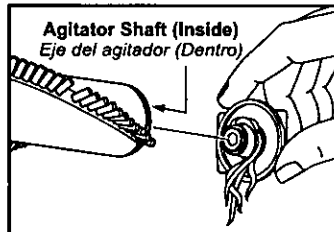
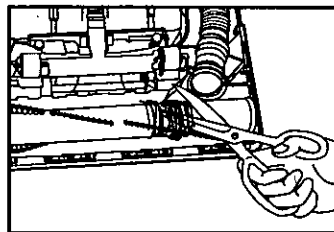

## Replacing Brushes / Cambiar los cepillos

- **When the bristles on the agitator are worn so that they do not touch a card held across the lower plate, the brushes should be replaced**  
*Cuando los cepillos del agitador estén gastados hasta que no pueden tocar una tarjeta tenida en la base inferior, se deben cambiar los cepillos*
- **Remove lower plate and agitator**  
*Quite la base inferior y el agitador*
- **Push out worn brushes**  
*Retire los cepillos desgastados*
- **Slide new brushes into slot, making sure not to reverse the brush and beater bar position (see agitator assembly illustration)**  
*Deslice los nuevos cepillos dentro las ranuras, asegúrese de no invertir la posición del cepillo y de la barra de respaldo del agitador (consulte el dibujo montaje de agitador a continuación)*
- **New brushes may be easier to install if they are soaked in warm water for a few minutes and then dried completely prior to installation**  
*Es posible instalar los cepillos nuevos con más facilidad si están dejados en agua tibia por unos pocos minutos y después están secados completamente antes de la instalación*
- **See exploded view below for correct assembly of parts**  
*Véase el diagrama grande abajo para el almacenaje correcto de piezas*
- **Position belt over belt groove on the agitator**  
*Coloque la correa sobre la ranura de la correa en el agitador*
- **Reinstall agitator and lower plate**  
*Reemplace el agitador y la base inferior*

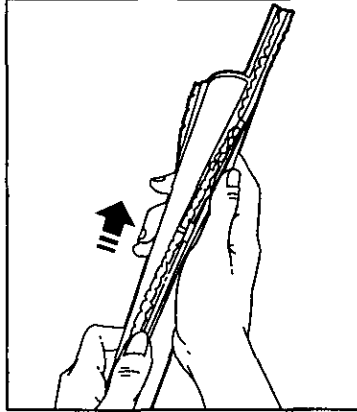
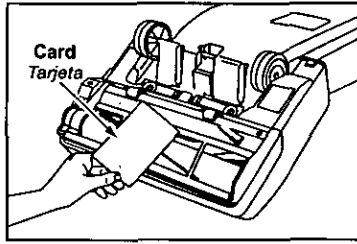

### Agitator Assembly / Montaje de agitador

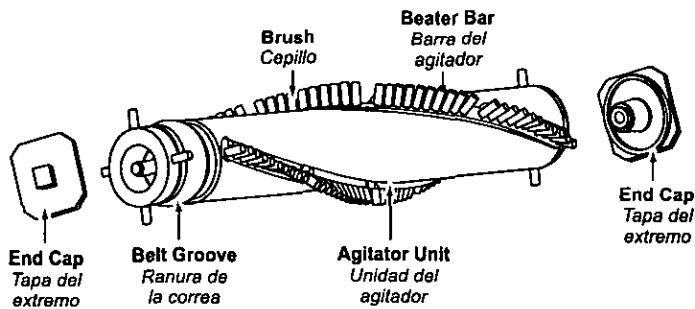

## Cleaning Exterior and Tools

### *Limpieza del exterior y de los herramientas*

- **Unplug cord from wall outlet**  
*Desenchufe de la toma en la pared*
- **Clean exterior using a clean, soft cloth that has been dipped in a solution of mild liquid detergent and water and wrung dry**  
*Limpie la parte exterior con un trapo suave y limpio que se ha metido en una solución de detergente líquido y agua y se ha escurrido hasta que esté seco*
- **DO NOT drip water on cleaner, wipe dry after cleaning**  
*No deje caer el agua en la aspiradora, seque con un trapo después de limpiarla*
- **DO NOT clean tools in dishwasher or clothes washer**  
*No limpie las herramientas en el lavaplatos ni en la lavadora de ropa*
- **Wash tools in warm soapy water, rinse and air dry**  
*Lave las herramientas en la tibia agua con jabón, enjuague y seque al aire*
- **DO NOT use tools if they are wet**  
*No use las herramientas si están mojados*

## Removing Clogs

### *Quitar de los residuos de basura en los conductos*

The hose located on the back of the vacuum cleaner carries the dirt from the nozzle up to the dust bag. If the hose should become clogged:

*La manguera situada en la parte posterior de la aspiradora lleva el polvo de la boquilla hasta la bolsa de polvo. Si hay residuos en la manguera:*

- **Unplug vacuum**  
*Desenchufe la aspiradora*
- **Pull open suction inlet cover and check for clogging**  
*Tire de la cubierta de aspiración y revise por los residuos*
- **Remove lower plate**  
*Quite la base inferior*
- **Remove hose from nozzle by lifting straight up**  
*Levante hacia arriba para quitar la manguera de la boquilla*
- **Inspect hose end and clear any obstructions**  
*Revise el extremo de la manguera y quite los obstáculos*
- **Reinstall hose and lower plate**  
*Reemplace la manguera y la base inferior*

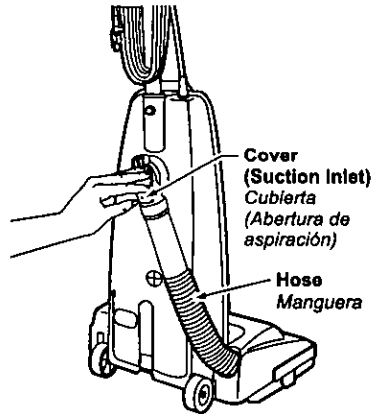

#### IF USING OPTIONAL TOOLS:

*Si se usan las herramientas opcionales:*

- **Disconnect any optional tools that may be in use and check them for clogging**  
*Desconecte las herramientas opcionales que se pueden estar usadas y reviselas si hay residuos*
- **Remove any clog from optional hose by stretching the hose in and out with the vacuum cleaner running**  
*Para quitar el residuo de la manguera opcional extienda la manguera a la extensión mínima y máxima cuando la aspiradora está encendida*

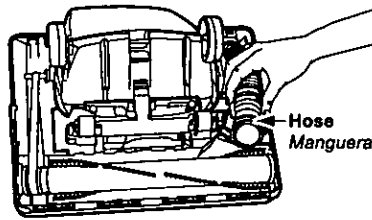

# WARRANTY

## Panasonic Commercial Vacuum Cleaner Limited Warranty

Panasonic Home and Commercial Products Company (referred to as "the warrantor") will repair this product with new or refurbished parts free of charge, in the U.S.A. or Puerto Rico, for one (1) year from the date of original purchase, in the event of a defect in materials or workmanship.

**This Limited Warranty Excludes both Labor and Parts for the following items:** disposable dust bags, filters, belts, light bulbs, agitator brushes and batteries (if supplied).

Carry-in or mail-in service in the U.S.A. can be obtained during the warranty period by contacting a Panasonic Services Company (PASC) Factory Servicenter listed in the Servicenter Directory, or by calling toll free, 1-888-350-9590, or by contacting your selling distributor. Carry-in or mail-in service in Puerto Rico can be obtained during the warranty period by calling the local Panasonic Sales Company telephone number listed in the Servicenter Directory.

This warranty is extended only to the original purchaser. A purchase receipt or other proof of date of original purchase will be required before warranty performance is rendered.

This warranty only covers failures due to defects in materials and workmanship which occur during normal use and does not cover damages which occur in shipment, or failures which are caused by products not supplied by the warrantor, or failures which result from accident, misuse, abuse, neglect, mishandling, misapplication, faulty installation, improper operation or maintenance, alteration, modification, power line surge, improper voltage supply, lightning damage, or service by anyone other than a Panasonic Authorized Servicenter, or damage that is attributable to acts of God.

### **LIMITS AND EXCLUSIONS:**

There are no express warranties except as listed above.

THE WARRANTOR SHALL NOT BE LIABLE FOR INCIDENTAL OR CONSEQUENTIAL DAMAGES RESULTING FROM THE USE OF THIS PRODUCT, OR ARISING OUT OF ANY BREACH OF THIS WARRANTY. ALL EXPRESS AND IMPLIED WARRANTIES, INCLUDING THE WARRANTIES OF MERCHANTABILITY AND FITNESS FOR A PARTICULAR PURPOSE, ARE LIMITED TO THE APPLICABLE WARRANTY PERIOD SET FORTH ABOVE.

Some states do not allow the exclusion or limitation of incidental or consequential damages, or limitations on how long an implied warranty lasts, so the above exclusions or limitations may not apply to you.

This warranty gives you specific legal rights and you may also have other rights which vary from state to state. If a problem with this product develops during or after the warranty period, you may contact your dealer or Servicenter. If the problem is not handled to your satisfaction, then write to the Customer Satisfaction Center at the listed address on the back cover.

# WHAT TO DO WHEN SERVICE IS NEEDED

## *Cuando necesita servicio*

If your Panasonic Vacuum Cleaner needs service, contact your selling dealer, or call, 1-888-350-9590 toll free to find a convenient servicenter. **DO NOT send the product to the Executive or Regional Sales offices. They are NOT equipped to make repairs.**

*Si su aspiradora Panasonic necesita servicio, por favor llame al vendedor o llame gratis al 1-888-350-9590 para encontrar un centro de servicio conveniente. **No mande el producto a las Executive o Regional Sales Offices. No están equipadas para arreglar estos productos.***

### If you ship the product

Carefully pack and send it prepaid, adequately insured and preferably in the original carton. Attach a postage-paid letter to the outside of the carton, which contains a description of your complaint. **DO NOT send the product to the Executive or Regional Sales Offices. They are NOT equipped to make repairs.**

### *Si manda el producto*

*Empaquete con cuidado en el cartón original si posible y mándelo prepagado y con seguro suficiente. Ponga una carta con sellos en la que describe su problema con el producto en el exterior del cartón. **No mande el producto a las Executive o Regional Sales Offices. No están equipadas para arreglar estos productos.***

### Customer's Record / *Récord de Comprador*

Model No. \_\_\_\_\_ Dealer's Name \_\_\_\_\_  
*Número de Modelo* \_\_\_\_\_ *Nombre del Vendedor* \_\_\_\_\_

Serial No. / *Número de Serie* \_\_\_\_\_

Dealer's Address / *Dirección del Vendedor* \_\_\_\_\_

Date of Purchase / *Fecha de Compra* \_\_\_\_\_

PANASONIC HOME & COMMERCIAL PRODUCTS  
COMPANY, DIVISION OF MATSUSHITA ELECTRIC  
CORPORATION OF AMERICA

One Panasonic Way  
4A-4  
Secaucus, New Jersey 07094

ACØ1ZBAWZØU  
CØ1ZBAWØØUØØ

Printed in U.S.A.  
*Impreso en EUA*