

# Panasonic®

COMMERCIAL VACUUM CLEANER  
*Commercial aspiradora*

## MC-V315

Operating Instructions  
*Instrucciones de operación*

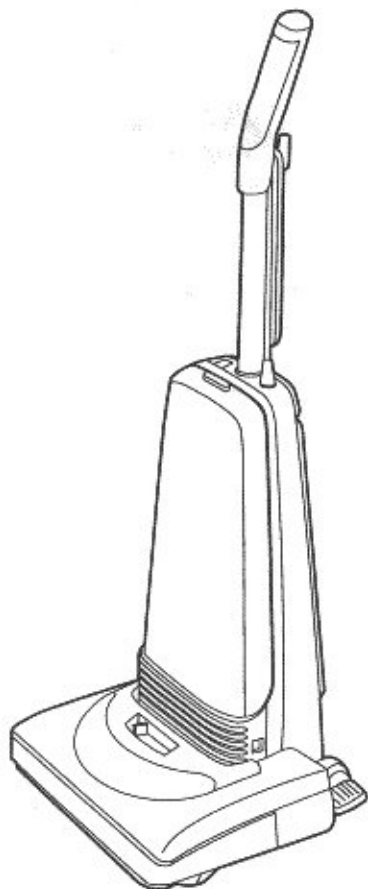

**Before operating your vacuum cleaner, please read these instructions completely.**

*Antes de usar su aspiradora, lea completamente estas instrucciones por favor.*

C01ZBAY00U00

# CONSUMER INFORMATION

Please read **IMPORTANT SAFETY INSTRUCTIONS** on page 5 before use. Read and understand all instructions.

## TO OUR VALUED CUSTOMER

We are very pleased to welcome you to the Panasonic family of products. Thank you for purchasing this product. Our intent is that you become one of our many satisfied customers.

**Proper assembly and safe use of your vacuum cleaner are your responsibilities. Your vacuum cleaner is intended for commercial use. The cleaner should be stored in a dry, indoor area. Read the Operating Instructions carefully for important use and safety information.**

**Special care is required when vacuuming certain types of carpet or floor covering. Always check the carpet or floor covering manufacturer's recommended cleaning instructions before vacuuming.**

## PLEASE PAY CLOSE ATTENTION TO ALL WARNING AND CAUTION STATEMENTS.



**WARNING** statements are designed to alert you to the possibility of personal injury, loss of human life, and/or damage to the vacuum cleaner and/or personal property if the instructions given are not followed.



**CAUTION** statements are designed to alert you to the possibility of damage to the vacuum cleaner and/or personal property if the instructions given are not followed.



### TO AVOID ELECTRICAL SHOCK

Never vacuum damp or wet surfaces or liquids.

**DO NOT** store machine outdoors.

Replace worn or frayed power cord immediately.

Unplug from outlet when not in use and before servicing.

### TO AVOID ACCIDENTS

Except for hand-held cleaners, keep machine on floor - not chairs, tables, steps, stairs, etc.

Store machine promptly after each use to prevent accidents such as tripping over power cord or machine.

Use machine and accessories only in a manner intended by the manufacturer.

The use of an extension cord is not recommended.

# TABLE OF CONTENTS / *Tabla de contenido*

<b>CONSUMER INFORMATION / Información para consumidor</b> .....	2-3
<b>IMPORTANT SAFETY INSTRUCTIONS</b> <i>Instrucciones importantes de seguridad</i> .....	5-6
<b>GROUNDING INSTRUCTIONS</b> <i>Instrucciones para hacer conexión a tierra</i> .....	7-8
<b>PARTS IDENTIFICATION / Identificación de piezas</b> .....	9
<b>ASSEMBLY / Montaje</b> .....	10
<b>Attaching Handle / Colocación del mango</b> .....	10
<b>Tool Storage / Almacenaje de herramientas</b> .....	11
<b>FEATURES / Características</b> .....	12
<b>Carpet Height Selector / Selector para el nivel de alfombra</b> .....	12
<b>Edge Cleaning / Limpieza para orillas</b> .....	12
<b>Motor Protector / Protector de motor</b> .....	12
<b>TO OPERATE CLEANER / Para operar la aspiradora</b> .....	13
<b>ON-OFF Switch / Control ON-OFF</b> .....	13
<b>Handle Adjustments / Ajustes del mango</b> .....	13
<b>Using Tools / Uso de herramientas</b> .....	14
<b>ROUTINE CARE OF CLEANER / Cuidado de rutina de la aspiradora</b> .....	15
<b>Cleaning Secondary Foam Filter</b> <i>Limpieza del segundo filtro de goma espuma</i> .....	15
<b>Replacing Electrostatic Exhaust Filter</b> <i>Cambio del filtro de escape de electrostática</i> .....	16
<b>Changing Dust Bag / Cambio de la bolsa para polvo</b> .....	17
<b>Removing and Installing Lower Plate</b> <i>Cambiar y insertar de la base inferior</i> .....	18
<b>Replacing Belt / Cambio de la correa</b> .....	19
<b>Cleaning Agitator / Limpieza del agitador</b> .....	19
<b>Replacing Agitator / Cambio del agitador</b> .....	20
<b>Cleaning Exterior and Tools / Limpieza del exterior y de los heramientas</b> .....	21
<b>Removing Clogs / Quitar de los residuos de basura en los conductos</b> .....	22
<b>BEFORE REQUESTING SERVICE / Antes de pedir servicio</b> .....	23-24
<b>NOTAS / Notas</b> .....	25
<b>WARRANTY / Garantía</b> .....	26-27
<b>WHAT TO DO WHEN SERVICE IS NEEDED / Cuando necesita servicio</b> .....	28

# IMPORTANT SAFETY INSTRUCTIONS

When using vacuum cleaner, basic precautions should always be followed, including the following:

## READ ALL INSTRUCTIONS BEFORE USING THIS VACUUM CLEANER



## WARNING

To reduce the risk of fire, electrical shock, injury:

1. **DO NOT** leave vacuum cleaner when plugged in. Unplug from outlet when not in use and before servicing.
2. To reduce the risk of fire, electric shock - **DO NOT** use outdoors or on wet surfaces.
3. **DO NOT** allow to be used as a toy. Close attention is necessary when used by or near children.
4. Use only as described in this manual. Use only manufacturer's recommended tools.
5. **DO NOT** use with damaged cord or plug. If vacuum cleaner is not working as it should, has been dropped, damaged, left outdoors, or dropped into water, return it to an authorized Panasonic Servicentre.
6. **DO NOT** pull or carry by cord, use cord as a handle, close door on cord, or pull cord around sharp edges or corners. **DO NOT** run vacuum cleaner over cord. Keep cord away from heated surfaces.
7. **DO NOT** unplug by pulling on cord. To unplug, grasp the plug, not the cord.
8. **DO NOT** handle plug or vacuum cleaner with wet hands.
9. **DO NOT** put any objects into openings. **DO NOT** use with any opening blocked; keep free of dust, lint, hair, and anything that may reduce air flow.
10. Keep hair, loose clothing, fingers, and all parts of body away from openings and moving parts.
11. **DO NOT** pick up anything that is burning or smoking, such as cigarettes, matches, or hot ashes.
12. **DO NOT** use without dust bag and/or filters in place.
13. Turn off all controls before unplugging.
14. Use extra care when cleaning on stairs.
15. **DO NOT** use cleaner to pick up flammable or combustible liquids such as gasoline or use in areas where they may be present.
16. Connect to a properly grounded outlet only. See "Grounding Instructions"

## SAVE THESE INSTRUCTIONS

# GROUNDING INSTRUCTIONS

This vacuum cleaner must be grounded. If it should malfunction or breakdown, grounding provides a path of least resistance for electric current to reduce the risk of electric shock. This vacuum cleaner is equipped with a cord having an equipment-grounding conductor and grounding plug. The plug must be plugged into an appropriate outlet that is properly installed and grounded in accordance with all local codes and ordinances.

## **DANGER**

Improper connection of the equipment-grounding conductor can result in a risk of electric shock. Check with a qualified electrician or service person if you are in doubt as to whether the outlet is properly grounded. Do not modify the plug provided with the vacuum cleaner – if it will not fit the outlet, have a proper outlet installed by a qualified electrician.

This vacuum cleaner is for use on a nominal 120-volt circuit, and has a grounding plug that looks like the plug illustrated in sketch A in the following Figure. Make sure that this vacuum cleaner is connected to an outlet having the same configuration as the plug.

No adapter should be used with this vacuum cleaner.

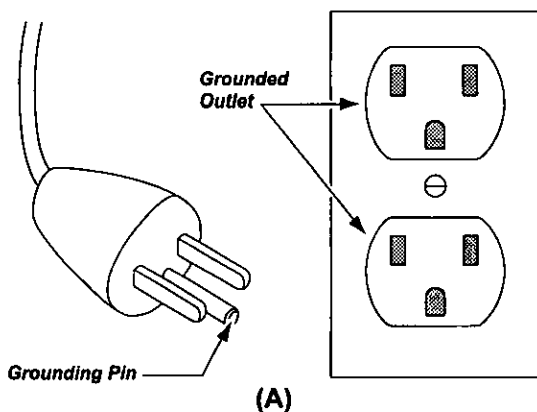

**Note:** Before you plug in your Panasonic vacuum cleaner, make sure that the voltage indicated on the rating plate located at the back of the vacuum cleaner is the same as your local supply.

# PARTS IDENTIFICATION

## Identificación de piezas

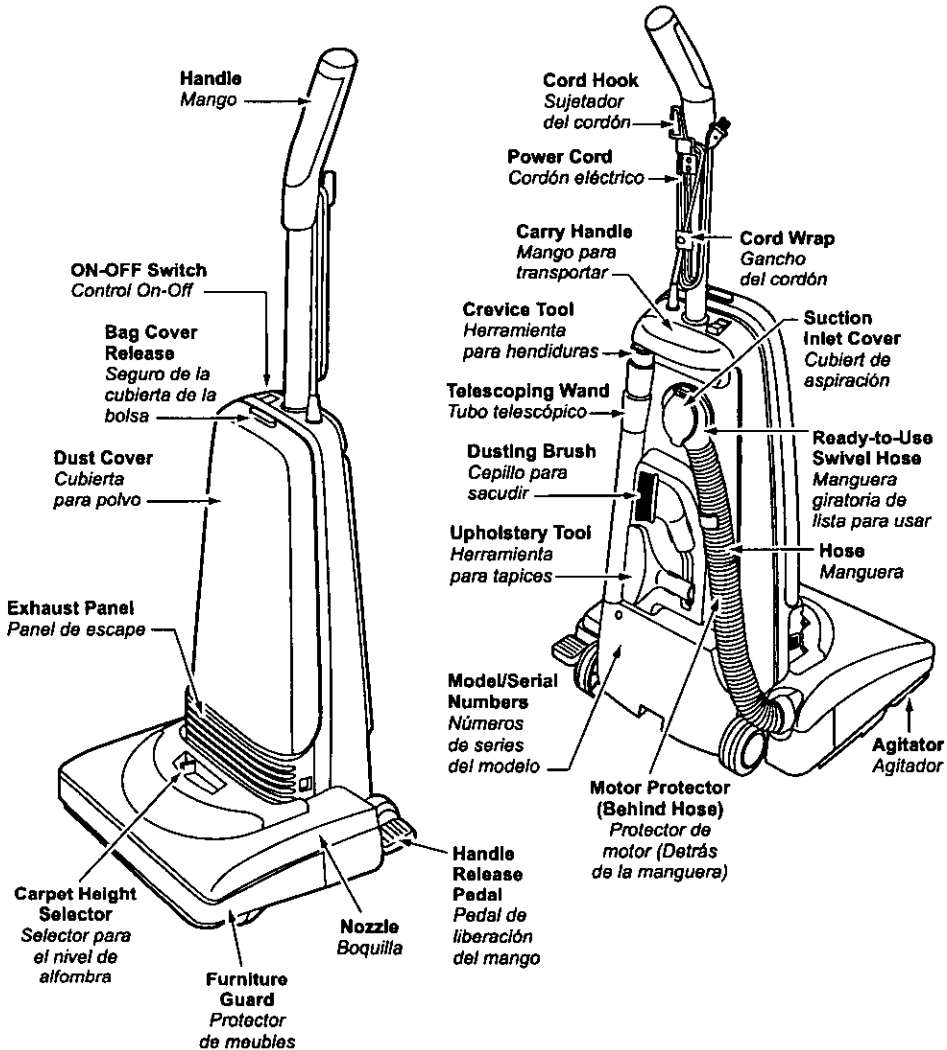

### FEATURE CHART / Diagrama de características (PANASONIC UPRIGHT VACUUM) (Aspiradora vertical Panasonic)

FEATURES Características	Power Voltaje	Motor Protector Protector de motor	Height Adjust Adjust de nivel	Cord Length Extensión de cordón
Model / Modelo MC-V315	120V. AC (60Hz) 10 A / 10 A	Yes Si	4 Position 4 position	50 Ft. (15.25 m) 15,25 m (50 pi)

# ASSEMBLY / Montaje

## Attaching Handle / Colocación del mango

1)

- **DO NOT plug in until assembly is complete**

*No enchufe hasta que el montaje esté completo*

- **Remove handle screw**

*Quite el tornillo del mango*

- **Insert handle with cord hook to the back of the cleaner**

*Meta el mango con el sujetador del cordón en la parte posterior de la aspiradora*

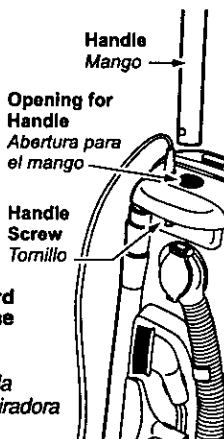

2)

- **Insert screw**

*Instale el tornillo*

- **Tighten screw**

*Apriete el tornillo*

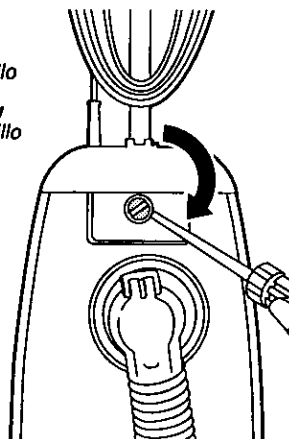

3)

- **Push power cord into cord clip in back of handle**

*Empuje el cordón eléctrico hacia el soporte del cordón en la parte posterior del mango*

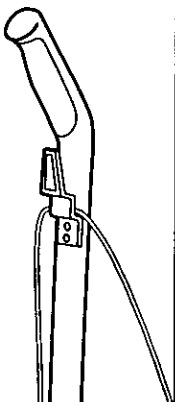

4)

- **Wrap power cord around cord hook**

*Envuelva el cordón eléctrico alrededor del sujetador del cordón*

- **Secure retainer (plug head) to power cord**

*Asegure la clavija en el cordón eléctrico*

- **Place cord wrap around bottom loop of power cord**

*Coloque el gancho del cordón alrededor del lazo inferior del cordón*

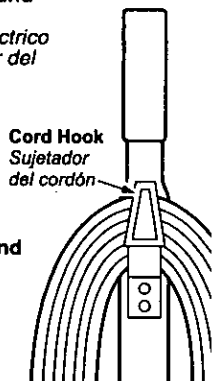

# Tool Storage / Almacenaje de herramientas

## Tools / Herramientas

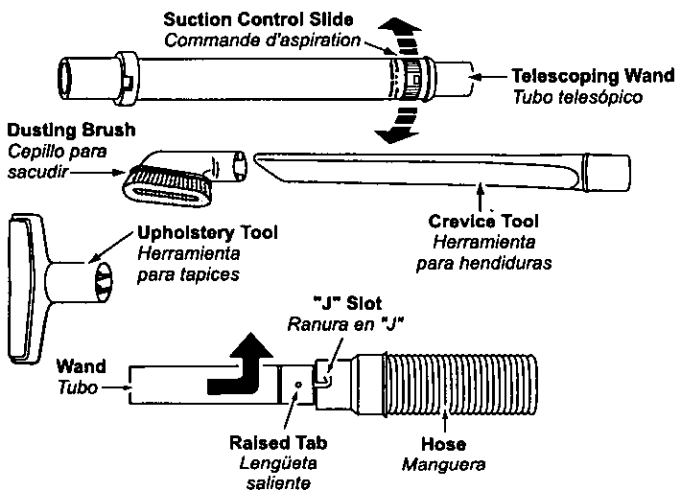

- **Some tools may already be stored on vacuum cleaner**  
*Es posible que ya se almacenen unas herramientas en la aspiradora*
- **Insert crevice tool, cleaning end first, into end of telescoping wand opposite the suction control**  
*Inserte la herramienta de hendiduras, limpiando el extremo primero, en el extremo del tubo telescópico opuesto al control de aspiración*

- **Place telescoping wand on back of cleaner with crevice tool on top**  
*Meta el tubo telescópico en la parte trasera de la aspiradora con la herramienta de hendiduras hacia arriba*

- **Store dusting brush and upholstery tool in rear of dust compartment**  
*Almacene el cepillo para polvo y la herramienta para tapices en la parte trasera de el compartimento para el polvo*

- **Insert hose into opening at back of nozzle as shown**  
*Inserte la manguera en la apertura en la parte trasera de la boquilla como se ve*

- **To use telescoping wand for cleaning, attach it to hose by aligning the two (2) raised tabs on wand with "J" slots in hose, guide tabs along grooves, twist to lock in place**  
*Para utilizar el tubo telescópico para limpiar, conectar el tubo a la manguera, alinee las dos (2) lengüetas levantadas en el tubo con las ranuras "J" en la manguera. Mueva las lengüetas hacia las ranuras, ruédelas para asegurar*

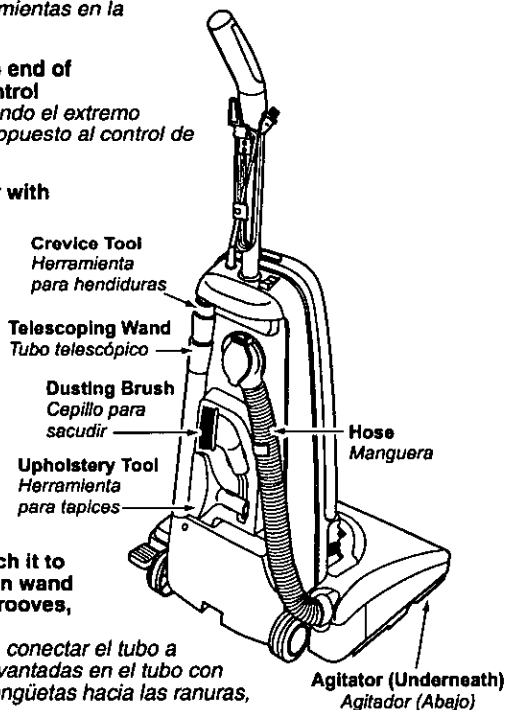







## FEATURES / Características

### Carpet Height Selector / Selector para el nivel de alfombra

- > Allows for adjustments to efficiently and safely clean different types of floors / Esta característica es para los ajustes para la limpieza eficiente y segura de muchos tipos de suelos
- > To select pile height setting, first turn off vacuum / Para seleccionar la posición de la altitud de la pelusa, apague la aspiradora primero
- > Tilt vacuum back and slide adjustment lever to desired setting / Incline la aspiradora hacia atrás y deslice el control de ajustes a la posición deseada

#### SUGGESTED CARPET HEIGHT SETTINGS:

Las posiciones sugeridas para el nivel de la alfombra:

-  shag carpet, long pile, plush, scatter rugs / pelo áspero y lanudo, pelo largo, felpa, alfombras o tapetes irregulares
-  medium to long pile / pelo mediano o poco largo
-  short to medium pile / pelo corto o mediano
-  very low pile / pelo muy corto

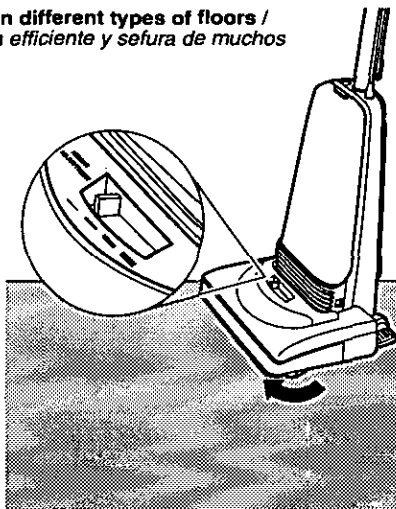

### Edge Cleaning / Limpieza para orillas

- > Edge cleaning feature provides for improved cleaning of carpets near walls and furniture / Use la característica de limpieza para orillas para aspirar con facilidad cerca de las paredes y los muebles

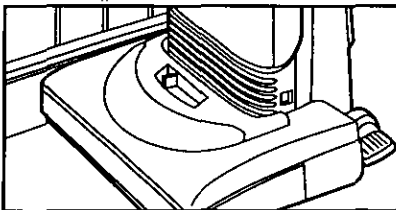

### Motor Protector / Protector de motor

- > Automatically opens to provide cooling air to the motor when a clog occurs or when dust bag needs changing / Se abre automáticamente para proveer el aire fresco al motor cuando hay unos residuos o cuando es necesario cambiar la bolsa de polvo
- > Motor protector may open when using tools / Es posible que el protector del motor se abra cuando se usan las herramientas
- > If motor protector opens, the vacuum will make a slightly different sound / Si se abre el protector del motor, la aspiradora hará un sonido poquito diferente

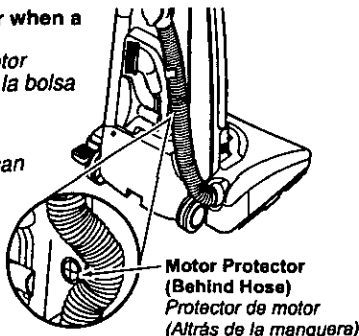

# TO OPERATE CLEANER

## *Para operar la aspiradora*

### ON-OFF Switch / Control ON-OFF

- **Ensure ON-OFF switch is OFF**  
*Asegúrese de que el control ON-OFF esté en la posición OFF*
- **Plug the power cord into 120V outlet**  
*Enchufe el cordón eléctrico en una toma de pared de 120 V*
- **ON position turns vacuum on**  
*La posición ON enciende la aspiradora*
- **OFF position turns vacuum off**  
*La posición OFF apaga la aspiradora*

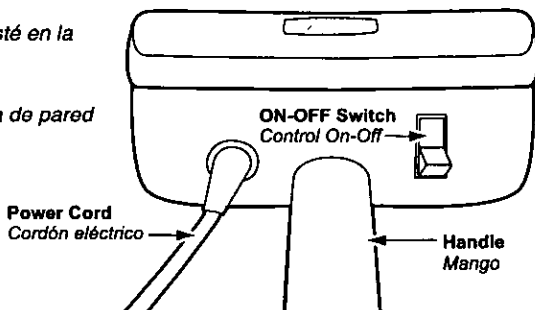

### Handle Adjustments / Ajustes del mango

- 1)
- **Step on handle release pedal to change handle position**  
*Pise en el pedal de liberación del mango para cambiar la posición del mango*

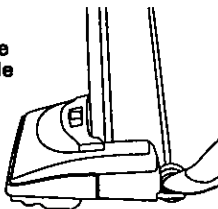

- 2)
- **Move vacuum to upright position for storage and tool use**  
*Mueva la aspiradora a la posición vertical para el almacenaje y el uso de las herramientas*

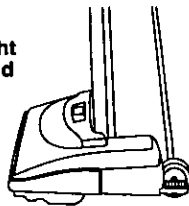

- 3)
- **Move vacuum to middle position for normal use**  
*Mueva la aspiradora a la posición mediana para el uso normal*

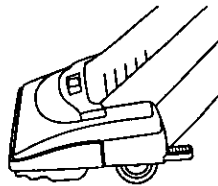

- 4)
- **Use low position for cleaning under furniture**  
*La posición baja para limpiar debajo de los muebles*

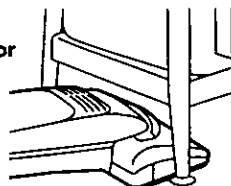

## Using Tools / Uso de herramientas

### ! CAUTION / CUIDADO

If tools are used, and vacuum is left in upright position, carpet damage could occur  
 Si se usan herramientas, y la aspiradora se deja en posición vertical, puede haber daño a la alfombra

Agitator rotates when using tools, use care to ensure that nothing comes into contact with agitator  
 El agitador gira cuando se utilizan las herramientas, tenga cuidado que nada toque el agitador

- Remove lower end of stretch hose from the back of the nozzle by twisting and pulling straight out  
 Quite el extremo inferior de la manguera de extensión de la parte trasera de la boquilla para girar y tirar hacia afuera
- The tools can be attached to hose, wand or crevice tool  
 Se puede conectar las herramientas con la manguera, el tubo o la herramienta de hendiduras

- Remove telescopic wand from vacuum  
 Quite el tubo telescópico de la aspiradora

- Remove crevice tool from telescopic wand  
 Quite la herramienta de hendiduras del tubo telescópico

- To extend wand, turn locking ring to UNLOCK position and pull out to full length  
 Para extender el tubo, gire el anillo de cierre a la posición UNLOCK y tire hacia afuera a la longitud máxima



- Turn locking ring to LOCK position  
 Gire el anillo de cierre a la posición LOCK

- DO NOT overextend your reach with hose as it could tip vacuum  
 No extienda demasiado la extensión de la manguera porque puede causar que la aspiradora vuelque

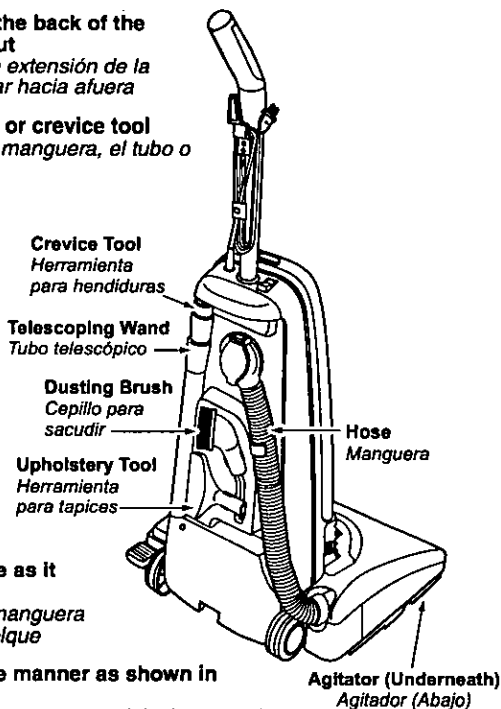
- Place all tools and hose back in the same manner as shown in TOOL STORAGE  
 Coloque otra vez todas las herramientas y la manguera del mismo modo que se ve en "Almacenaje de herramientas"



### TOOL USE / Uso de herramientas

TOOL / Herramienta	CLEANING AREA / Área para limpiar				
	Furniture Meubles	Cushions Cojines	Drapes Cortinas	Stairs Escaleras	Walls Paredes
CREVICE TOOL Herramienta para hendiduras 	X	X	X	X	X
DUSTING BRUSH Cepillo para sacudir 	X		X	X	X
UPHOLSTERY TOOL Herramienta para tapices 	X	X	X		

Always clean tools before using  
 Siempre limpie las herramientas antes de usarlas

# ROUTINE CARE OF CLEANER

## Cuidado de rutina de la aspiradora

Performing the following tasks will keep your new Panasonic vacuum cleaner operating at peak performance levels and will ensure these high levels for years to come. Check the **BEFORE REQUESTING SERVICE** section in this manual for recommendations on performing some of these tasks to help solve various problems that may occur.

*Siguiendo las instrucciones dadas, se nueva aspiradora Panasonic funcionará al nivel máximo y continuará funcionando por mucho años en el futuro. Lea la sección "Antes de pedir servicio" en este manual para las recomendaciones para arreglar unos problemas que puedan ocurrir.*

## Cleaning Secondary Foam Filter

### Limpieza del segundo filtro de goma espuma

#### CAUTION / CUIDADO

To prevent damage to vacuum cleaner, the secondary foam filter must be kept clean  
*Para prevenir daño a la aspiradora, el segundo filtro de goma espuma debe mantenerse limpio*

- The secondary foam filter protects the motor  
*El segundo filtro de goma espuma protege el motor*
- Check filter when installing a new dust bag  
*Al instalar una nueva bolsa de polvo revise el filtro*
- If dirty, pull filter from bottom of dust compartment and clean by rinsing in water  
*Si está sucio, tire del filtro del fondo del compartimento de polvo y límpielo enjuagando con agua*
- When dry, slide filter back into place  
*Cuando esté seco deslice el filtro a su lugar*
- Ensure filter is fully inserted under plastic rib projections  
*Asegúrese de que el filtro está instalado debajo de las lengüetas plásticas*

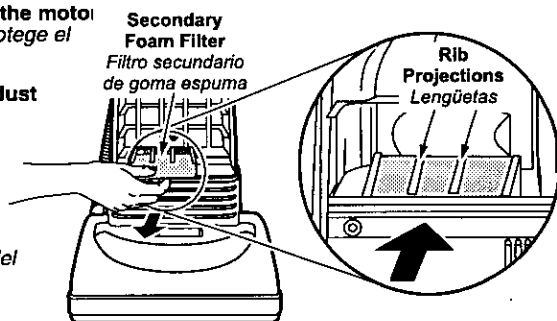

# Replacing Electrostatic Exhaust Filter

## Cambio del filtro de escape de electrostática

- **The electrostatic exhaust filter removes dirt from recirculated air**  
*El filtro de escape HEPA quita el polvo del aire reciclado*
- **Check filter when installing a new dust bag**  
*Revise el filtro al instalar una nueva bolsa de polvo*
- **To check filter, place handle in low position**  
*Para revisar el filtro, coloque el mango en la posición baja*
- **Press inward on both sides of exhaust panel and remove by pulling forward**  
*Apriete hacia adentro en los dos lados del panel de escape y quite para tirar hacia adelante*
- **Remove filter if dirty**  
*Quite el filtro si está sucio*
- **Place new filter in dust cover DO NOT CLEAN WITH WATER\***  
*Coloque el filtro nuevo en la cubierta de polvo No limpie con agua\**
- **Position new filter so slits in filter fit around the four raised pins**  
*Coloque el nuevo filtro para que las hendiduras quepan alrededor de las calquijas levantadas*

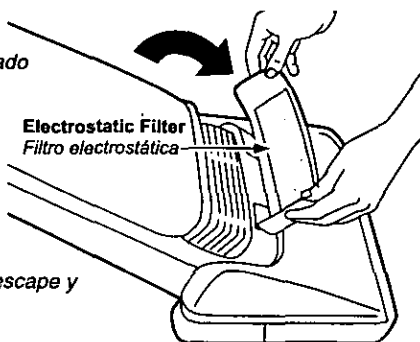



**\*Filter cannot be cleaned and should be replaced at least once each year**  
**\*No se puede limpiar el filtro y se debe cambiarlo a lo menos una vez cada año**

# Changing Dust Bag

## *Cambio de la bolsa para polvo*

Always operate vacuum with genuine Panasonic Type U3 Standard or U6 Electrostatic dust bags installed. Panasonic dust bags may be purchased through any authorized Panasonic dealer or ordered from service company. An optional cloth bag is available

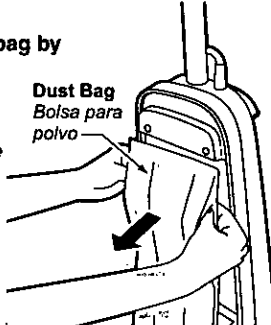
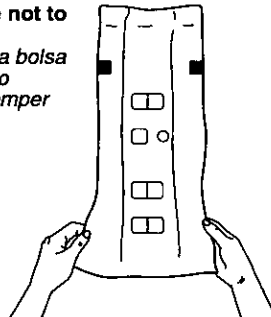
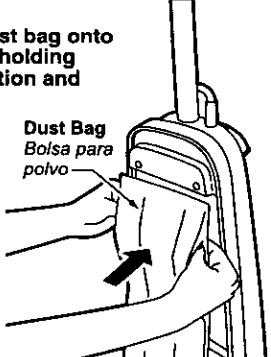
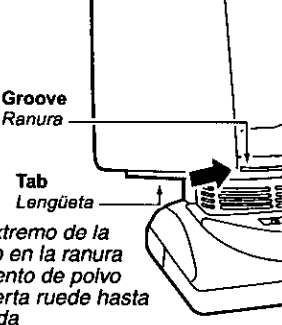
*Siempre opere la aspiradora con las bolsas Panasonic Type U3 Standard U6 Electrostatic instaladas. Se puede comprar las bolsas de polvo en cualquier vendedor autorizado Panasonic o mandar de una compañía de servicio. Se puede condeguir una bolsa opcional de tela.*

<p>1)</p> <p>➤ <b>Press release button and pull outward to remove dust cover</b>  <i>Apriete el botón de liberación y tire hacia afuera para quitar la cubierta para polvo</i></p> <div style="display: flex; align-items: center;"> <div style="margin-right: 10px;"> <p>Release Button Botón de liberación</p> <p>Bag Cover Cubierta de la bolsa</p> </div>  </div>	<p>2)</p> <p>➤ <b>Remove dust bag by grasping cardboard portion and pulling out</b>  <i>Agarre la parte de cartón de la bolsa y empuje hacia afuera para quitar la bolsa de polvo</i></p> <div style="display: flex; align-items: center;">  <div style="margin-left: 10px;"> <p>Dust Bag Bolsa para polvo</p> </div> </div>
<p>3)</p> <p>➤ <b>Spread out new dust bag, taking care not to tear bag</b>  <i>Extienda la nueva bolsa de polvo teniendo cuidado de no romper la bolsa</i></p> 	<p>4)</p> <p>➤ <b>Attach new dust bag onto bag holder by holding cardboard portion and pushing back</b>  <i>Teniendo la parte de cartón y empujando hacia atrás instale la nueva bolsa de polvo en el soporte para la bolsa</i></p> <div style="display: flex; align-items: center;">  <div style="margin-left: 10px;"> <p>Dust Bag Bolsa para polvo</p> </div> </div>
<p>5)</p> <p>➤ <b>Reinsert tab on end of dust cover into groove on dust compartment to allow cover to rotate closed</b>  <i>Reinstale la lengüeta en el extremo de la cubierta de polvo en la ranura en el compartimento de polvo para que la cubierta ruede hasta la posición cerrada</i></p> <div style="display: flex; align-items: center;"> <div style="margin-right: 10px;"> <p>Groove Ranura</p> <p>Tab Lengüeta</p> </div>  </div>	<p>6)</p> <p>➤ <b>Rotate dust cover up into closed position and press into place without pinching dust bag</b>  <i>Ruede la cubierta de polvo hasta la posición cerrada y aprétela en su lugar sin apretar la bolsa de polvo</i></p> 

## Removing and Installing Lower Plate

### *Cambiar y insertar de la base inferior*

#### **WARNING / AVERTENCIA**

**Before servicing any parts, disconnect vacuum from electrical outlet**  
*Desenchufe la aspiradora de la toma de pared antes de hacerles servicio a las piezas*

- **Always place paper under nozzle anytime lower plate is removed to protect floor**  
*Siempre coloque un papel debajo de la boquilla para proteger el suelo cada vez se quita la base inferior*
- **Place handle in upright position and turn vacuum over to expose lower plate**  
*Coloque el mango en la posición vertical y vuelque la aspiradora para exponer la base inferior*
- **Release lower plate by pressing two (2) latches and two (2) locking tabs inward as shown**  
*Para liberar la placa inferior, apriete hacia adentro los dos (2) pestillos y las dos (2) lengüetas de cierre como se muestra*
- **Remove lower plate and remove any residue that may exist in belt area**  
*Quite la base inferior y quite los residuos que exista en el área de la correa*
- **Reinstall lower plate by hooking front end of lower plate into slots on front of nozzle housing**  
*Para reinstalar la base inferior, enganche el extremo delantero de la base inferior en las ranuras en el montaje delantero de la boquilla*
- **Press lower plate until locking tabs snap into place then push two (2) latches outward**  
*Apriete la placa inferior hasta que las lengüetas de cierre estén bien instaladas y luego empuje hacia afuera los dos (2) pestillos*

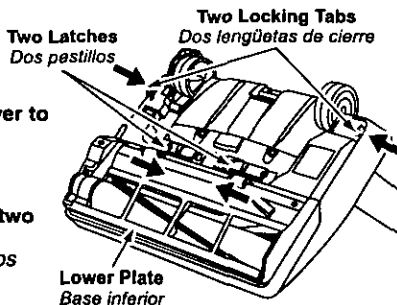

## Replacing Belt / Cambio de la correa

- **Replace belt whenever a burning rubber smell caused by excessive slippage occurs / Cambie la correa cuando ocurra un olor de goma que quema causado por un patinaje excesivo**
- **Remove lower plate**  
*Quite la base inferior*
- **Remove agitator by carefully lifting out**  
*Al levantar con cuidado quite el agitador*
- **Remove worn or broken belt**  
*Quite la correa gastada o rota*
- **Loop new belt (Panasonic Type UB8 only) around motor shaft and brush pulley; see illustration for correct belt routing**  
*Envuelva la correa nueva (Panasonic Type UB8 solamente) en el eje del motor y la polea de cepillo, véase el diagrama para envolver la correa*
- **Clean agitator and replace end caps**  
*Limpie el agitador y cambie las tapitas del extremo*
- **Reinstall agitator back into nozzle housing grooves**  
*Reinstale el agitador en las ranuras del compartimento de la boquilla*
- **After reinstalling the agitator, turn it by hand to make sure that belt is not twisted or pinched and that all rotating parts turn freely**  
*Después de instalar el agitador, rueda a mano para que asegure que la correa no esté torcida ni apretada y que rueden libremente todas las piezas rodantes*
- **Reinstall lower plate**  
*Reemplace la base inferior*

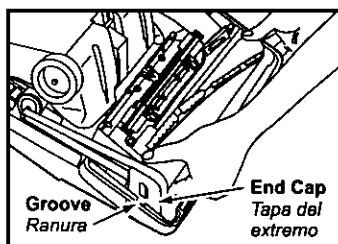
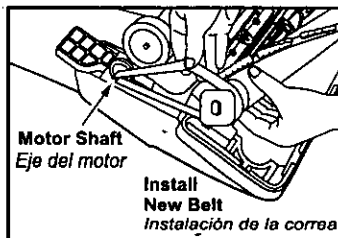
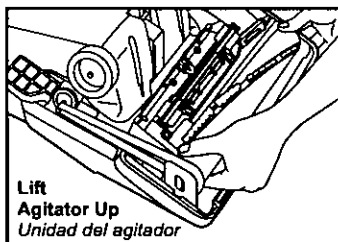

## Cleaning Agitator / Limpieza del agitador

- **Clean agitator after every five uses and every time the belt is replaced**  
*Limpie el agitador después de cada cinco utilizaciones y cada vez que se cambia la correa*
- **Remove lower plate**  
*Quite la base inferior*
- **Cut off any carpet pile and lint entangled around agitator with a pair of scissors**  
*Corte con unas tijeras el pelo de alfombra y la pelusa envueltos en el agitador*
- **Remove agitator**  
*Quite el agitador*
- **Remove any string or debris located on the end caps or agitator shaft**  
*Quite los hilos o los residuos ubicados en los tapas del extremo, en las arandelas o en el eje del agitador*
- **Reinstall agitator and lower plate**  
*Reemplace el agitador y la base inferior*

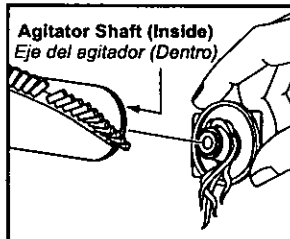
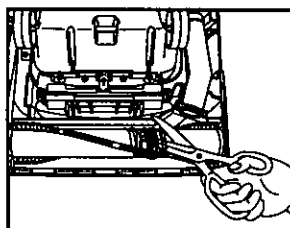



## Replacing Brushes / Cambiar los cepillos

- **When the bristles on the agitator are worn so that they do not touch a card held across the lower plate, the brushes should be replaced**  
*Cuando los cepillos del agitador estén gastados hasta que no pueden tocar una tarjeta tenida en la base inferior, se deben cambiar los cepillos*
- **Remove lower plate and agitator**  
*Quite la base inferior y el agitador*
- **Push out worn brushes**  
*Retire los cepillos desgastados*
- **Slide new brushes into slot, making sure not to reverse the brush and beater bar position (see agitator assembly illustration)**  
*Deslice los nuevos cepillos dentro las ranuras, asegúrese de no invertir la posición del cepillo y de la barra de respaldo del agitador (consulte el dibujo montaje de agitador a continuación)*
- **New brushes may be easier to install if they are soaked in warm water for a few minutes and then dried completely prior to installation**  
*Es posible instalar los cepillos nuevos con más facilidad si están dejados en agua tibia por unos pocos minutos y después están secados completamente antes de la instalación*
- **See exploded view below for correct assembly of parts**  
*Véase el diagrama grande abajo para el almacenaje correcto de piezas*
- **Position belt over belt groove on the agitator**  
*Coloque la correa sobre la ranura de la correa en el agitador*
- **Reinstall agitator and lower plate**  
*Reemplace el agitador y la base inferior*

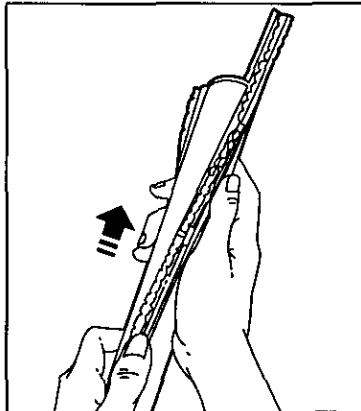
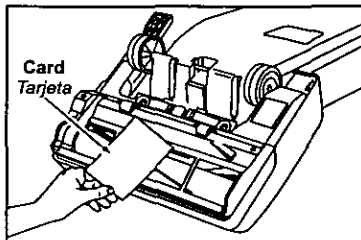

## Agitator Assembly / Montaje de agitador

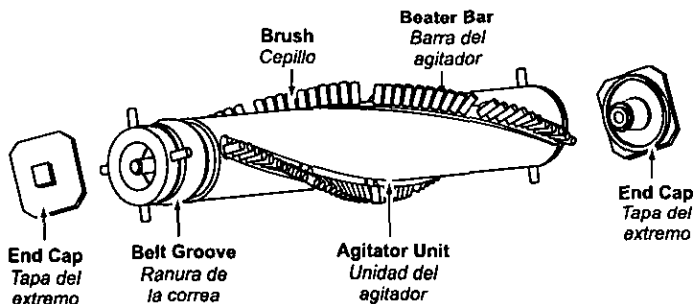

## **Cleaning Exterior and Tools**

### *Limpieza del exterior y de los herramientas*

- **Unplug cord from wall outlet**  
*Desenchufe de la toma en la pared*
- **Clean exterior using a clean, soft cloth that has been dipped in a solution of mild liquid detergent and water and wrung dry**  
*Limpie la parte exterior con un trapo suave y limpio que se ha metido en una solución de detergente líquido y agua y se ha escurrido hasta que esté seco*
- **DO NOT drip water on cleaner, wipe dry after cleaning**  
*No deje caer el agua en la aspiradora, seque con un trapo después de limpiarla*
- **DO NOT clean tools in dishwasher or clothes washer**  
*No limpie las herramientas en el lavaplatos ni en la lavadora de ropa*
- **Wash tools in warm soapy water, rinse and air dry**  
*Lave las herramientas en la tibia agua con jabón, enjuague y seque al aire*
- **DO NOT use tools if they are wet**  
*No use las herramientas si están mojados*

## Removing Clogs

### Quitar de los residuos de basura en los conductos

The hose located on the back of the vacuum cleaner carries the dirt from the nozzle up to the dust bag. If the hose should become clogged:

La manguera situada en la parte posterior de la aspiradora lleva el polvo de la boquilla hasta la bolsa de polvo. Si hay residuos en la manguera:

- **Unplug vacuum**  
*Desenchufe la aspiradora*
- **Pull open suction inlet cover and check for clogging**  
*Tire de la cubierta de aspiración y revise por los residuos*
- **Remove hose from back of nozzle**  
*Quite la manguera de la parte trasera de la boquilla*
- **Plug in vacuum cleaner and turn on**  
*Enchufe la aspiradora y enciéndala*
- **Stretch hose in and out to remove clog**  
*Estire la manguera hasta la extensión máxima y mínima para quitar los residuos*
- **If clog still exists, turn vacuum cleaner OFF and UNPLUG POWER CORD**  
*Si ya hay los residuos, apague la aspiradora y Desenchufe el cordón eléctrico*
- **Remove lower plate**  
*Quite la placa inferior*
- **Inspect nozzle area and nozzle pipe for clogs**  
*Revise el área de la boquilla y la pipa de la boquilla por residuos*
- **Reinstall lower plate and hose**  
*Reemplace la base inferior y la manguera*

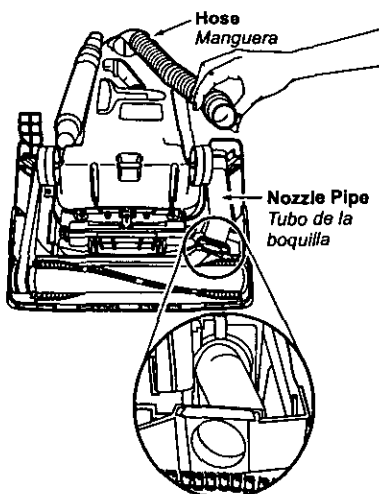
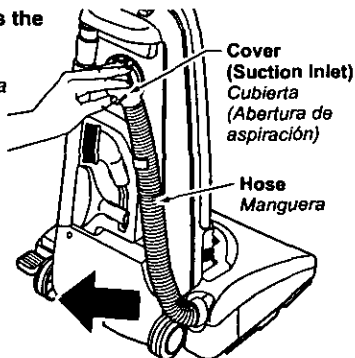

# BEFORE REQUESTING SERVICE



## **WARNING** *Electric Shock or Personal Injury Hazard.*

*Disconnect the electrical supply before servicing or cleaning the unit. Failure to do so could result in electric shock or personal injury from cleaner suddenly starting.*

**Review this chart to find do-it-yourself solutions for minor performance problems. Any service needed, other than those described in these Operating Instructions, should be performed by an authorized service representative.**

<b>PROBLEM</b>	<b>POSSIBLE CAUSE</b>	<b>POSSIBLE SOLUTION</b>
<b>Cleaner will not run.</b>	<ol style="list-style-type: none"> <li>1. Unplugged at wall outlet.</li> <li>2. ON-OFF switch not turned on.</li> <li>3. Tripped circuit breaker/blown fuse at household service panel.</li> </ol>	<ol style="list-style-type: none"> <li>1. Plug in firmly. Push ON-OFF switch to ON.</li> <li>2. Push ON-OFF switch to ON.</li> <li>3. Reset circuit breaker or replace fuse.</li> </ol>
<b>Poor job of dirt pickup.</b>	<ol style="list-style-type: none"> <li>1. Full or clogged dust bag.</li> <li>2. Broken belt.</li> <li>3. Carpet height setting incorrect.</li> <li>4. Clogged hose or nozzle.</li> <li>5. Hose not inserted fully.</li> <li>6. Worn agitator.</li> <li>7. Hole in hose.</li> <li>8. Dust cover improperly installed.</li> <li>9. Belt not installed on motor shaft.</li> </ol>	<ol style="list-style-type: none"> <li>1. Change bag.</li> <li>2. Replace belt.</li> <li>3. Set in the correct position.</li> <li>4. Clean hose or nozzle area.</li> <li>5. Insert hose.</li> <li>6. Replace agitator.</li> <li>7. Replace hose.</li> <li>8. Properly install dust cover.</li> <li>9. Install belt on motor shaft.</li> </ol>
<b>Dust escapes the paper bag.</b>	<ol style="list-style-type: none"> <li>1. Bag improperly installed.</li> <li>2. Bag torn.</li> </ol>	<ol style="list-style-type: none"> <li>1. Properly install bag.</li> <li>2. Replace bag.</li> </ol>
<b>Cleaner picks up moveable rugs or pushes too hard.</b>	<ol style="list-style-type: none"> <li>1. Wrong pile height setting.</li> </ol>	<ol style="list-style-type: none"> <li>1. Adjust setting.</li> </ol>

# WARRANTY

## Panasonic Commercial Vacuum Cleaner Limited Warranty

Panasonic Home and Commercial Products Company (referred to as "the warrantor") will repair this product with new or refurbished parts free of charge, in the U.S.A. or Puerto Rico, for one (1) year from the date of original purchase, in the event of a defect in materials or workmanship.

**This Limited Warranty Excludes both Labor and Parts for the following items:** disposable dust bags, filters, belts, light bulbs, agitator brushes and batteries (if supplied).

Carry-in or mail-in service in the U.S.A. can be obtained during the warranty period by contacting a Panasonic Services Company (PASC) Factory Servicenter listed in the Servicenter Directory, or by calling toll free, 1-888-350-9590, or by contacting your selling distributor. Carry-in or mail-in service in Puerto Rico can be obtained during the warranty period by calling the local Panasonic Sales Company telephone number listed in the Servicenter Directory.

This warranty is extended only to the original purchaser. A purchase receipt or other proof of date of original purchase will be required before warranty performance is rendered.

This warranty only covers failures due to defects in materials and workmanship which occur during normal use and does not cover damages which occur in shipment, or failures which are caused by products not supplied by the warrantor, or failures which result from accident, misuse, abuse, neglect, mishandling, misapplication, faulty installation, improper operation or maintenance, alteration, modification, power line surge, improper voltage supply, lightning damage, or service by anyone other than a Panasonic Authorized Servicenter, or damage that is attributable to acts of God.

### **LIMITS AND EXCLUSIONS:**

There are no express warranties except as listed above.

THE WARRANTOR SHALL NOT BE LIABLE FOR INCIDENTAL OR CONSEQUENTIAL DAMAGES RESULTING FROM THE USE OF THIS PRODUCT, OR ARISING OUT OF ANY BREACH OF THIS WARRANTY. ALL EXPRESS AND IMPLIED WARRANTIES, INCLUDING THE WARRANTIES OF MERCHANTABILITY AND FITNESS FOR A PARTICULAR PURPOSE, ARE LIMITED TO THE APPLICABLE WARRANTY PERIOD SET FORTH ABOVE.

Some states do not allow the exclusion or limitation of incidental or consequential damages, or limitations on how long an implied warranty lasts, so the above exclusions or limitations may not apply to you.

This warranty gives you specific legal rights and you may also have other rights which vary from state to state. If a problem with this product develops during or after the warranty period, you may contact your dealer or Servicenter. If the problem is not handled to your satisfaction, then write to the Customer Satisfaction Center at the listed address on the back cover.

# WHAT TO DO WHEN SERVICE IS NEEDED

## *Quando necesita servicio*

If your Panasonic Vacuum Cleaner needs service, contact your selling dealer, or call, 1-888-350-9590 toll free to find a convenient servicenter. **DO NOT send the product to the Executive or Regional Sales offices. They are NOT equipped to make repairs.**

*Si su aspiradora Panasonic necesita servicio, por favor llame al vendedor o llame gratis al 1-888-350-9590 para encontrar un centro de servicio conveniente. No mande el producto a las Executive o Regional Sales Offices. No están equipadas para arreglar estos productos.*

### If you ship the product

Carefully pack and send it prepaid, adequately insured and preferably in the original carton. Attach a postage-paid letter to the outside of the carton, which contains a description of your complaint. **DO NOT send the product to the Executive or Regional Sales Offices. They are NOT equipped to make repairs.**

### *Si manda el producto*

*Empaquete con cuidado en el cartón original si posible y mándelo prepagado y con seguro suficiente. Ponga una carta con sellos en la que describe su problema con el producto en el exterior del cartón. No mande el producto a las Executive o Regional Sales Offices. No están equipadas para arreglar estos productos.*

### Customer's Record / *Récord de Comprador*

Model No. \_\_\_\_\_ Dealer's Name \_\_\_\_\_  
Número de Modelo \_\_\_\_\_ Nombre del Vendedor \_\_\_\_\_

Serial No. / Número de Serie \_\_\_\_\_

Dealer's Address / Dirección del Vendedor \_\_\_\_\_

Date of Purchase / Fecha de Compra \_\_\_\_\_

PANASONIC HOME & COMMERCIAL PRODUCTS  
COMPANY, DIVISION OF MATSUSHITA ELECTRIC  
CORPORATION OF AMERICA

One Panasonic Way  
4A-4  
Secaucus, New Jersey 07094

AC01ZBAYZ0U  
C01ZBAY00U00

Printed in U.S.A.  
Impreso en EUA