

Panasonic®

VACUUM CLEANER
Aspirateur
Aspiradora

MC-V5005

Operating Instructions
Manuel d'utilisation
Instrucciones de operación

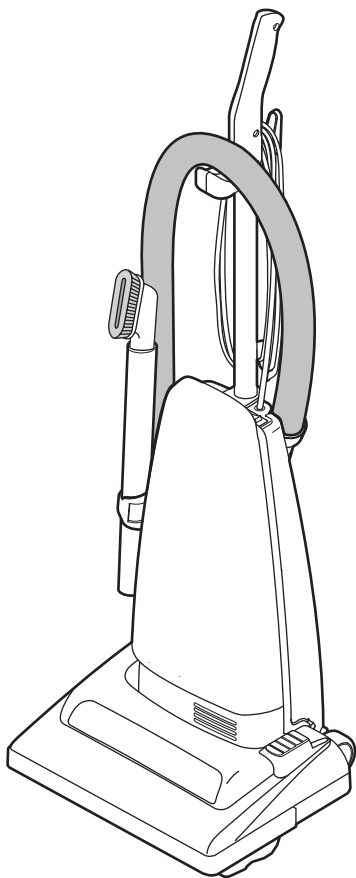

Before operating your vacuum cleaner, please read these instructions completely.

Avant d'utiliser l'appareil, il est recommandé de lire attentivement ce manuel.

Antes de usar su aspiradora, lea completamente estas instrucciones por favor.

C01ZCHG10000

CONSUMER INFORMATION

Please read **IMPORTANT SAFETY INSTRUCTIONS** on page 5 before use. Read and understand all instructions.

TO OUR VALUED CUSTOMER

We are very pleased to welcome you to the Panasonic family of products. Thank you for purchasing this product. Our intent is that you become one of our many satisfied customers.

Proper assembly and safe use of your vacuum cleaner are your responsibilities. Your vacuum cleaner is intended only for household use. The cleaner should be stored in a dry, indoor area. Read the Operating Instructions carefully for important use and safety information.

Special care is required when vacuuming certain types of carpet or floor covering. Always check the carpet or floor covering manufacturer's recommended cleaning instructions before vacuuming.

PLEASE PAY CLOSE ATTENTION TO ALL WARNING AND CAUTION STATEMENTS.



WARNING

WARNING statements are designed to alert you to the possibility of personal injury, loss of human life, and/or damage to the vacuum cleaner and/or personal property if the instructions given are not followed.



CAUTION

CAUTION statements are designed to alert you to the possibility of damage to the vacuum cleaner and/or personal property if the instructions given are not followed.



WARNING

TO AVOID ELECTRICAL SHOCK

Never vacuum damp or wet surfaces or liquids.
DO NOT store machine outdoors.
Replace worn or frayed power cord immediately.
Unplug from outlet when not in use and before servicing.

TO AVOID ACCIDENTS

Except for hand-held cleaners, keep machine on floor - not chairs, tables, steps, stairs, etc.
Store machine promptly after each use to prevent accidents such as tripping over power cord or machine.
Use machine and accessories only in a manner intended by the manufacturer.
The use of an extension cord is not recommended.

IMPORTANT SAFETY INSTRUCTIONS

To reduce the risk of fire, electrical shock, injury: When using your vacuum cleaner, basic precautions should always be followed, including the following:



WARNING

1. **Read** all instructions in this manual before assembling or using your vacuum cleaner.
2. **Use** your cleaner only as described in this manual. Use only with Panasonic recommended attachments.
3. **Disconnect** electrical supply before servicing or cleaning out the brush area. Failure to do so could result in electrical shock or the brush suddenly starting.
4. **Do not** leave cleaner when plugged in. Unplug from outlet when not in use and before servicing.
5. **To reduce** the risk of electrical shock - Do not use outdoors or on wet surfaces.
6. **Do not** allow to be used as a toy. Close attention is necessary when used by or near children.
7. **Do not** use with a damaged cord or plug. If cleaner is not working as it should, has been dropped, damaged, left outdoors, or dropped in water, return it to a Panasonic Service Center.
8. **Do not** pull or carry by cord, use cord as a handle, close a door on cord, or pull cord around sharp edges or corners. Do not run cleaner over cord. Keep cord away from heated surfaces.
9. **Do not** unplug by pulling on cord. To unplug, grasp the plug, not the cord.
10. **Do not** handle plug or cleaner with wet hands.
11. **Do not** put any objects into openings.
12. **Do not** use with any opening blocked; keep free of dust, lint, hair, and anything that may reduce air flow.
13. **Keep** hair, loose clothing, fingers, and all parts of body away from openings and moving parts.
14. **Turn off** all controls before unplugging.
15. **Use** extra care when cleaning on stairs. Do not put on chairs, tables, etc. Keep on floor.
16. **Do not** use cleaner to pick up flammable or combustible liquids (gasoline, cleaning fluid, perfumes, etc.), or use in areas where they may be present. The fumes from these substances can create a fire hazard or explosion.
17. **Do not** pick up anything that is burning or smoking, such as cigarettes, matches, or hot ashes.
18. **Do not** use cleaner without dust bag and/or filters in place.
19. **Do not** operate cleaner without the belt access door properly installed (if applicable).
20. **Unplug** before connecting Air Turbine. (if applicable).
21. **You are** responsible for making sure that your vacuum cleaner is not used by anyone unable to operate it properly.

SAVE THESE INSTRUCTIONS

THIS VACUUM CLEANER IS INTENDED FOR HOUSEHOLD USE ONLY

NOTE: Before you plug in your Panasonic vacuum cleaner, make sure that the voltage indicated on the rating plate located at the back of the vacuum cleaner is the same as your local electrical supply.

TABLE OF CONTENTS

CONSUMER INFORMATION	2
IMPORTANT SAFETY INSTRUCTIONS	5
PARTS IDENTIFICATION	10-11
ASSEMBLY	12
Attaching Handle	12
FEATURES	14
Using Cord Hook	14
Automatic Self Adjusting Nozzle	14
Edge Cleaning	14
Motor Protector	16
TO OPERATE CLEANER	16
Power Cord	16
ON-OFF Switch	16
Handle Adjustments	18
ROUTINE CARE OF CLEANER	20
Cleaning Secondary Foam Filter	20
Changing Dust Bag	20-22
Removing and Installing Lower Plate	24
Replacing Headlight Bulb	26
Replacing Belt	26-28
Cleaning Agitator	28
Replacing Agitator	30
Cleaning Exterior	30
Removing Clogs	32
BEFORE REQUESTING SERVICE	34
WARRANTY	37-38
Notes	41-43
WHAT TO DO WHEN SERVICE IS NEEDED	44

PARTS IDENTIFICATION

Nomenclature

Identificación de piezas

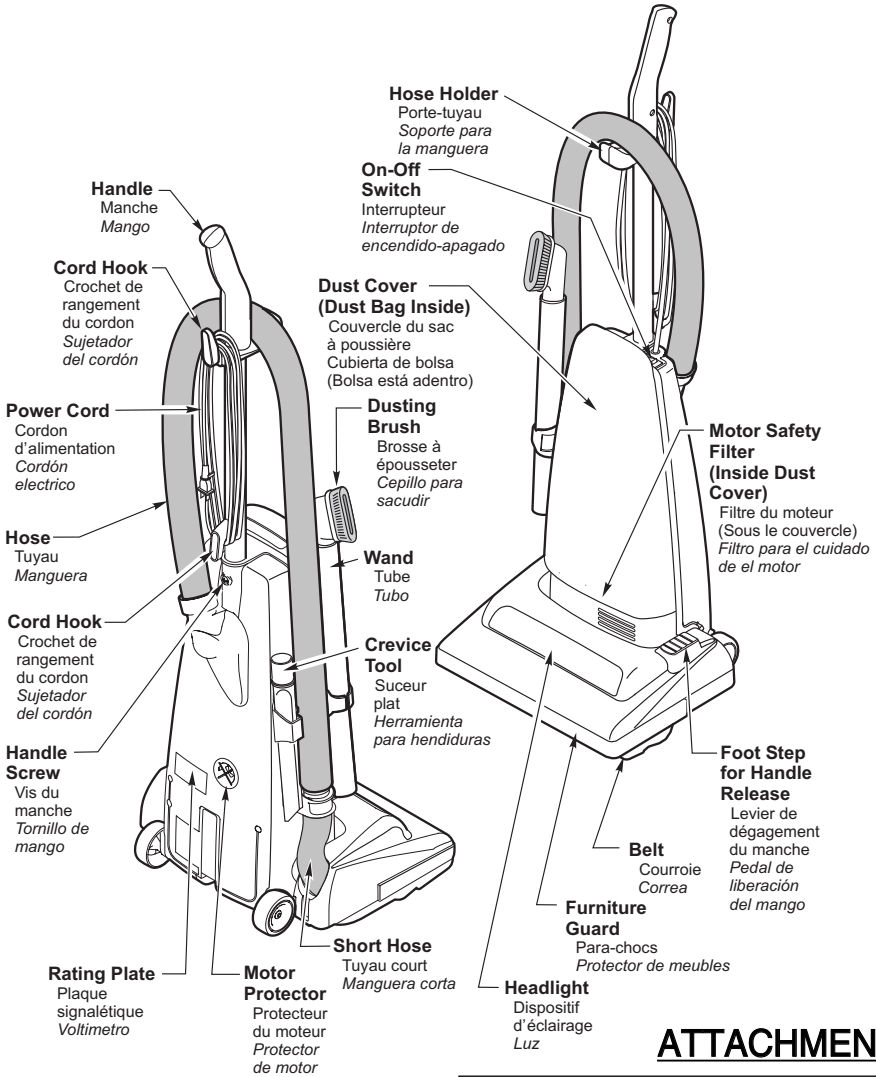

ATTACHMENTS

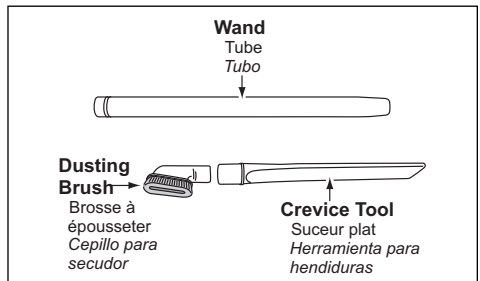

FEATURE CHART

Power	Motor Protector	Cord Length	Tools
120V AC(60Hz)	Yes	7.6 m (25 Ft.)	Yes

Tableau des caractéristiques

Alimentation	Protecteur du moteur	Longueur du cordon	Accessoires
120V c.a. (60Hz)	Oui	7,6 m (25 pi)	Oui

Diagrama de características

Voltaje	Protector de motor	Extensión de cordón	Herramientas
9.1 A / 9,1 A	Si	7,6 m (25 pi)	Si

ASSEMBLY

Attaching Handle

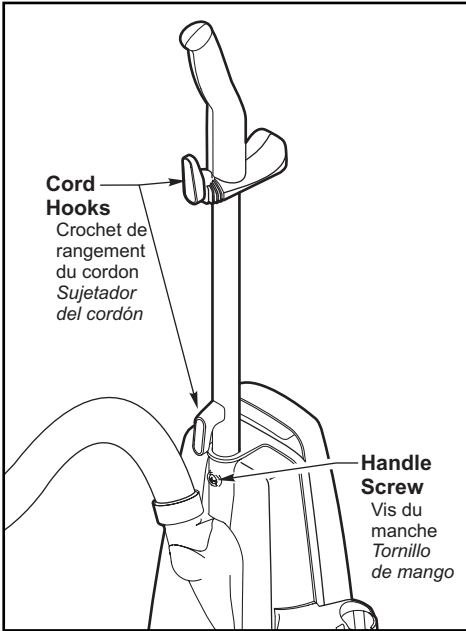

- 1)
 - **DO NOT** plug in until assembly is complete.
 - Remove handle screw.
 - Insert handle with cord hooks to the back of the cleaner.

- 2)
 - Insert screw.
 - Tighten screw.

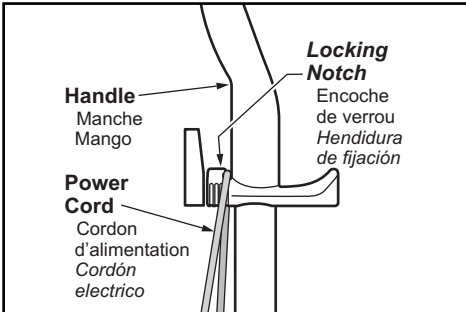

- 3)
 - Push power cord into cord clip.

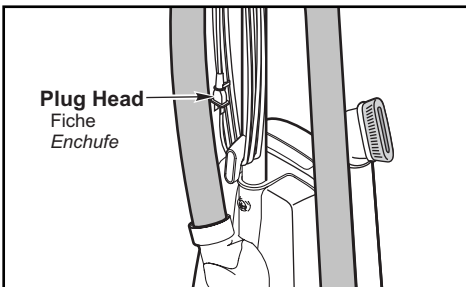

- 4)
 - Wrap power cord around cord hooks.
 - Secure retainer (plug head) to power cord.

FEATURES

Using Cord Hook

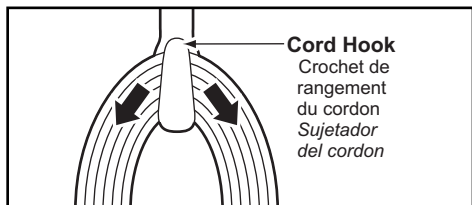

- 1)
 - Detach plug head from power cord.
 - Rotate cord hook down to release cord.
- 2)
 - Return the cord hook to the upright position before attempting to rewind the cord.

Automatic Self Adjusting Nozzle

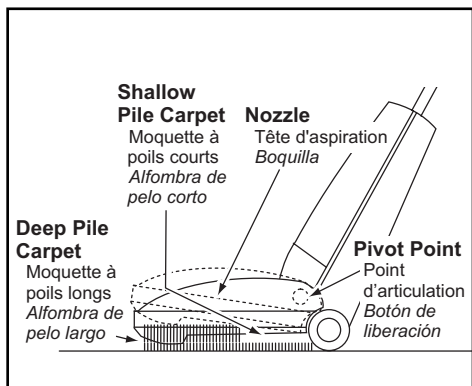

- The nozzle of your Panasonic upright vacuum cleaner automatically adjusts to any carpet pile height.
- Feature allows nozzle to float evenly over carpet pile surfaces.
- No manual adjustments required.

Edge Cleaning

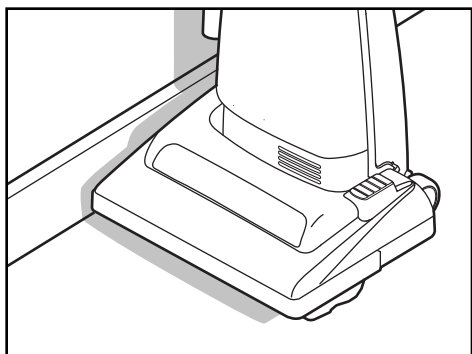

- Edge cleaning feature enables improved cleaning of carpets near walls and furniture.

Motor Protector

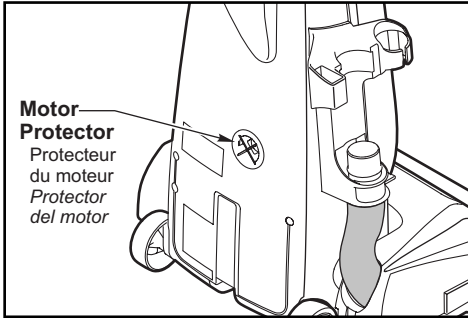

- The motor protector automatically opens to provide cooling air to the motor when a clog occurs or when dust bag needs changing.
- Motor protector may open when using tools.
- If motor protector opens, the vacuum will make a slightly different sound.

Note: Do not block motor protector.

TO OPERATE CLEANER

Power Cord

NOTE: To reduce the risk of electrical shock, this vacuum has a polarized plug, one blade is wider than the other. This plug will fit in a polarized outlet only one way. If the plug does not fit fully in the outlet, reverse the plug. If it still does not fit, contact a qualified electrician to install the proper outlet. **DO NOT CHANGE THE PLUG IN ANY WAY.** Only use outlets near the floor.

ON-OFF Switch

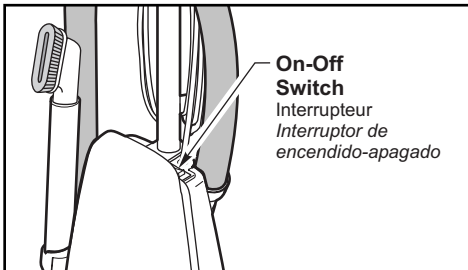

- Ensure ON-OFF switch is OFF.
- Plug the power cord into 120V outlet.
- ON position turns vacuum on.
- OFF position turns vacuum off.

Handle Adjustments

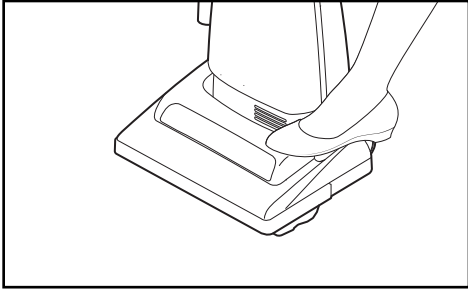

1)

- Step on handle release pedal to change handle position.



2)

- Move vacuum to upright position for storage and tool use.



3)

- Move vacuum to middle position for normal use.

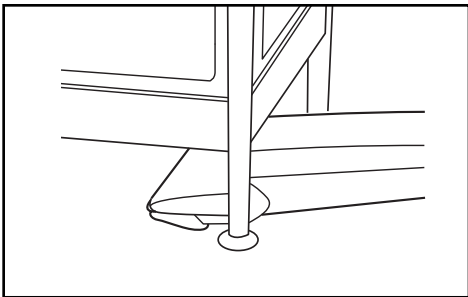

4)

- Use low position for cleaning under furniture.

ROUTINE CARE OF CLEANER

Performing the following tasks will keep your new Panasonic vacuum cleaner operating at peak performance levels and will ensure these high levels for years to come. Check the **BEFORE REQUESTING SERVICE** section in this manual for recommendations on performing some of these tasks to help solve various problems that may occur.

Cleaning Secondary Foam Filter

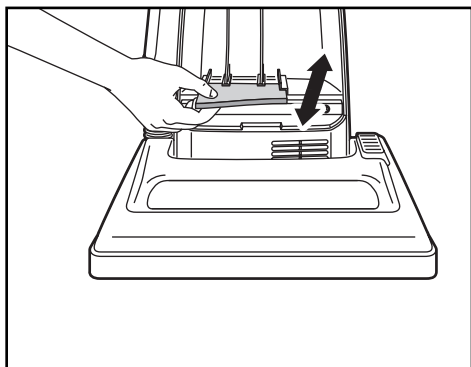

- Secondary foam filter protects motor.
- Check filter when installing a new dust bag.
- If dirty, pull filter from bottom of dust compartment and clean by rinsing in water.
- When dry, slide filter back into place.
- Ensure filter is fully inserted under plastic rib projections.

Changing Dust Bag

Always operate vacuum with genuine Panasonic Type U3 Standard or U6 Electrostatic dust bags installed. Panasonic dust bags may be purchased through any authorized Panasonic dealer or ordered from service company.

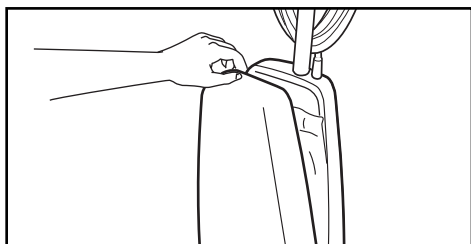

- 1)
- Pull outward on dust cover grip to remove the dust cover.

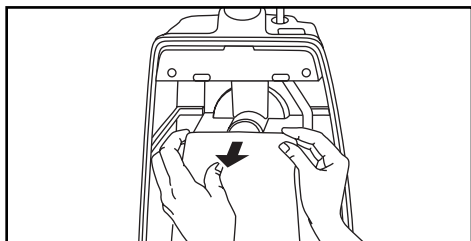

- 2)
- Remove dust bag by grasping cardboard portion and pulling out.

Changing Dust Bag

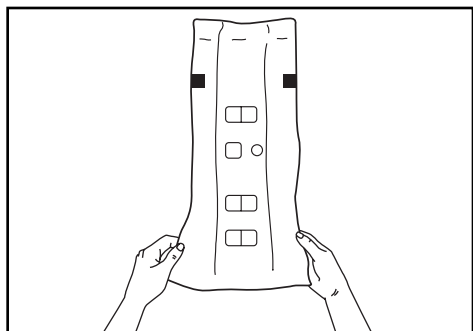

3)

- Spread out new dust bag, taking care not to tear bag.

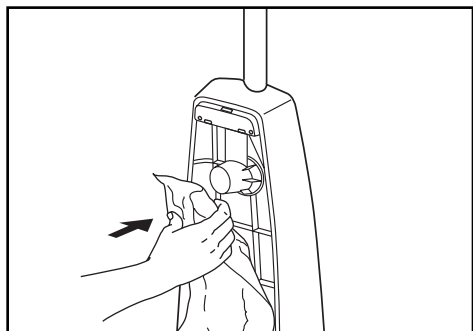

4)

- Attach new dust bag onto bag holder by holding cardboard portion and pushing back.

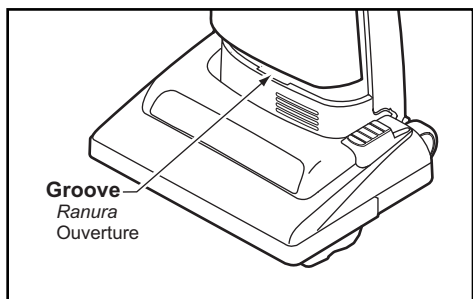

5)

- Reinsert tab on end of dust cover into groove on dust compartment to allow cover to rotate closed.

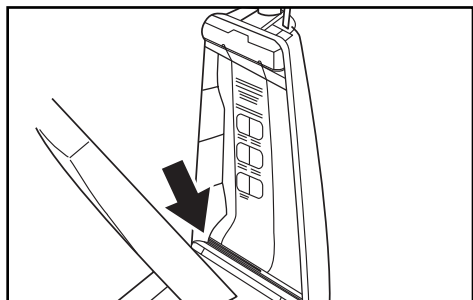

6)

- Rotate dust cover up into closed position and press into place without pinching dust bag.



WARNING Electrical Shock or Personal Injury Hazard

Disconnect the electrical supply before servicing or cleaning the unit.
Failure to do so could result in electrical shock or personal injury from cleaner suddenly starting.

Removing and Installing Lower Plate

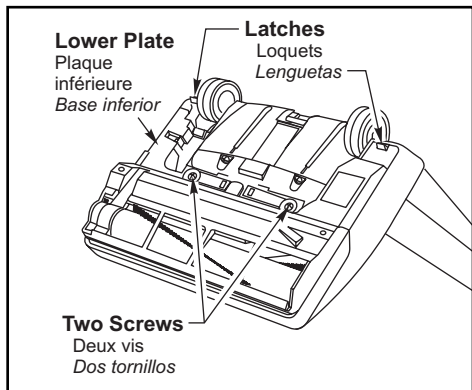

- **Before servicing any parts, disconnect vacuum from electrical outlet.**
- **Place paper under nozzle anytime lower plate is removed to protect floor.**
- **Place handle in upright position and turn vacuum over to expose lower plate.**
- **Release lower plate by removing two (2) screws.**
- **Remove lower plate and remove any residue that may exist in belt area.**

- **Reinstall lower plate by hooking front end of lower plate into slots on front of nozzle housing.**

- **Press lower plate into place and reinstall two (2) screws.**

Replacing Headlight Bulb

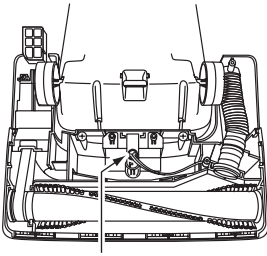

Bulb Socket Assembly
Assemblage de la lampe
Casquillo portálámparas

- Remove lower plate.
- Grasp the bulb socket assembly and pull upward while moving it back and forth.
- Remove old bulb from the bulb socket assembly by pushing in while turning counterclockwise.
- Replace bulb by pushing in while turning clockwise.
- Only use a bulb rated 130 V AC-15 Watts or less.
- Reassemble bulb socket assembly into nozzle housing by pushing it back down into slot and reinstall bulb socket screw.
- Reinstall lower plate.

Replacing Belt

Motor Drive Shaft

Arbre du moteur
Eje del motor

Belt
Courroie
Correa

Agitator
Agitateur
Agitador

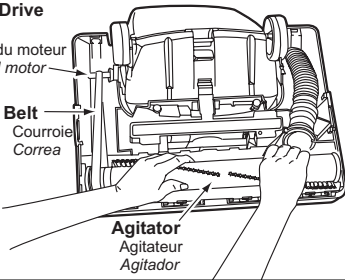

- Remove lower plate.
- Remove agitator by carefully lifting out.

Replacing Belt

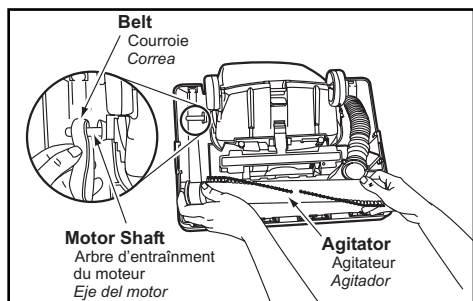

- Remove worn or broken belt.
- Loop new belt (Panasonic Type UB8 only) around motor shaft and belt pulley; see illustration for correct belt routing.
- Reinstall agitator back into nozzle housing grooves.
- After reinstalling the agitator, turn it by hand to make sure that belt is not twisted or pinched and that all rotating parts turn freely.

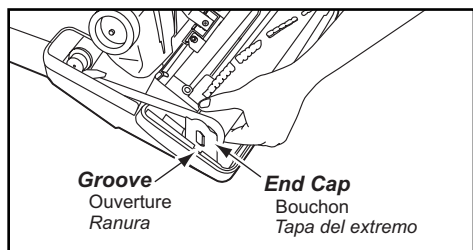

- Reinstall lower plate.

Cleaning Agitator

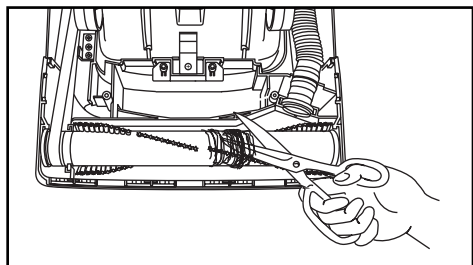

- Clean agitator after every five uses and every time the belt is replaced.
- Remove lower plate.
- Cut off any carpet pile and lint entangled around agitator with a pair of scissors.
- Remove agitator.
- Remove any string or debris located on the end caps.
- Reinstall agitator and lower plate.

Replacing Agitator

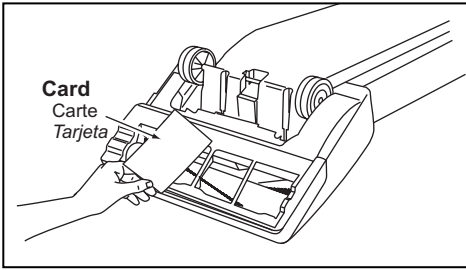

- When the bristles on the agitator are worn so that they do not touch a card held across the lower plate, the agitator should be replaced.
- Remove lower plate and agitator.
- Position belt over belt pulley on the new agitator.
- Reinstall agitator and lower plate.

Agitator Assembly

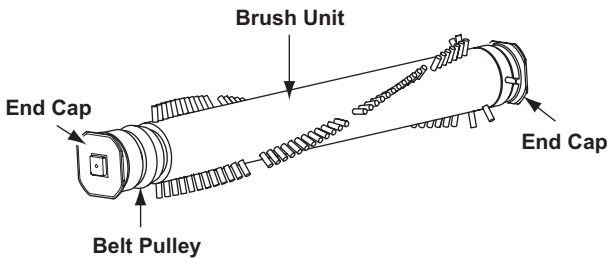

Cleaning Exterior

- Unplug cord from wall outlet.
- Clean exterior using a clean, soft cloth that has been dipped in a solution of mild liquid detergent and water and wrung dry.
- DO NOT drip water on cleaner, wipe dry after cleaning.
- DO NOT clean tools in dishwasher or clothes washer.
- Wash tools in warm, soapy water, rinse and air dry.
- DO NOT use tools if they are wet.

Removing Clogs



WARNING Electrical Shock or Personal Injury Hazard

Disconnect the electrical supply before servicing or cleaning the unit. Failure to do so could result in electrical shock or personal injury from cleaner suddenly starting.

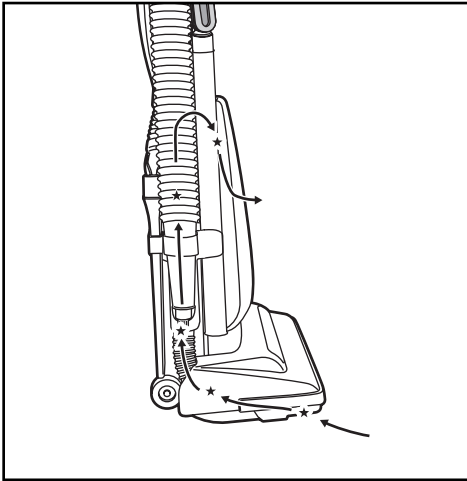

For best cleaning results, keep the airflow passage clear.

- Unplug vacuum.
- Check each starred area occasionally for clogs.
- Disconnect the hose from the nozzle hose and check the hose for clogging.
- Inspect hose end and clear any obstructions.
- Reinstall hose and lower plate.
- While running the vacuum cleaner with the hose disconnected, stretch the hose in and out to remove the clog.
- If the clog still exists, turn the vacuum OFF and unplug the power cord.
- Turn the vacuum cleaner over, exposing the underside.
- Remove the lower plate. Remove the short nozzle hose from the housing by lifting it straight up.
- Inspect the hose end and clear it of any obstructions. Reinstall the short nozzle hose and lower plate.

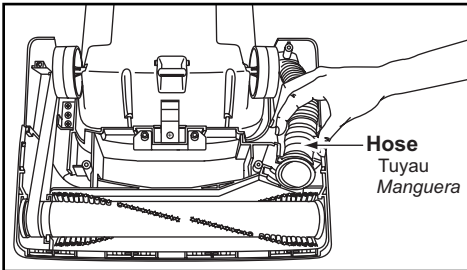

BEFORE REQUESTING SERVICE



WARNING *Electric Shock or Personal Injury Hazard.*

Disconnect the electrical supply before servicing or cleaning the unit. Failure to do so could result in electric shock or personal injury from cleaner suddenly starting.

Review this chart to find do-it-yourself solutions for minor performance problems. Any service needed, other than those described in these Operating Instructions, should be performed by an authorized service representative.

PROBLEM	POSSIBLE CAUSE	POSSIBLE SOLUTION
Cleaner will not run.	<ol style="list-style-type: none"> 1. Unplugged at wall outlet. 2. ON-OFF switch not turned on. 3. Tripped circuit breaker/blown fuse at household service panel. 	<ol style="list-style-type: none"> 1. Plug in firmly. Push ON-OFF switch to On. 2. Push ON-OFF switch to ON. 3. Reset circuit breaker or replace fuse.
Poor job of dirt pickup.	<ol style="list-style-type: none"> 1. Full or clogged dust bag. 2. Broken belt. 3. Clogged hose or nozzle. 4. Hose not inserted fully. 5. Worn agitator. 6. Dust cover improperly installed. 	<ol style="list-style-type: none"> 1. Change bag. 2. Replace belt. 3. Clean hose or nozzle area. 4. Insert hose. 5. Replace agitator. 6. Properly install dust cover.
Dust escapes the paper bag.	<ol style="list-style-type: none"> 1. Bag improperly installed. 2. Bag torn. 	<ol style="list-style-type: none"> 1. Properly install bag. 2. Replace bag.

WARRANTY

Panasonic Vacuum Cleaner Limited Warranty (United States)

Panasonic Home and Commercial Products Company (collectively referred to as "the warrantor") will repair this product with new or refurbished parts free of charge, in the U.S.A. or Puerto Rico for one (1) year from the date of original purchase in the event of a defect in materials or workmanship.

This Limited Warranty Excludes both Labor and Parts for the following items which require normal replacement: Disposable Dust Bag, Filters, Belts, Light Bulbs, Agitator Brushes and Batteries (if supplied).

Carry-in or mail-in service in the U.S.A. can be obtained during the warranty period by contacting a Panasonic Services Company (PASC) Factory Servicenter listed in the Servicenter Directory. Or call, toll free, 1-800-211-PANA (7262) to locate a PASC Authorized Servicenter. Carry-in or mail-in service in Puerto Rico can be obtained during the warranty period by calling the local Panasonic Sales Company telephone number listed in the Servicenter Directory.

This warranty is extended only to the original purchaser. A purchase receipt or other proof of date of original purchase will be required before warranty performance is rendered.

This warranty only covers failures due to defects in materials and workmanship which occur during normal use and does not cover damages which occur in shipment, or failures which are caused by products not supplied by the warrantor, or failures which result from accident, misuse, abuse, neglect, mishandling, misapplication, faulty installation, improper operation or maintenance, alteration, modification, power line surge, improper voltage supply, lightning damage, commercial use such as hotel, office, restaurant or other business or rental use of the product, or service by anyone other than a PASC Authorized Servicenter, or damage that is attributable to acts of God.

LIMITS AND EXCLUSIONS:

There are no express warranties except as listed above.

THE WARRANTOR SHALL NOT BE LIABLE FOR INCIDENTAL OR CONSEQUENTIAL DAMAGES RESULTING FROM THE USE OF THIS PRODUCT, OR ARISING OUT OF ANY BREACH OF THIS WARRANTY. ALL EXPRESS AND IMPLIED WARRANTIES, INCLUDING THE WARRANTIES OF MERCHANTABILITY AND FITNESS FOR A PARTICULAR PURPOSE, ARE LIMITED TO THE APPLICABLE WARRANTY PERIOD SET FORTH ABOVE.

Some states do not allow the exclusion or limitation of incidental or consequential damages, or limitations on how long an implied warranty lasts, so the above exclusions or limitations may not apply to you.

This warranty gives you specific legal rights and you may also have other rights which vary from state to state. If a problem with this product develops during or after the warranty period, you may contact your dealer or Servicenter. If the problem is not handled to your satisfaction, then write to the Consumer Affairs Department at the listed address on the back cover.

WARRANTY

Panasonic Canada Inc.
5770 Ambler Drive, Mississauga, Ontario L4W 2T3

PANASONIC PRODUCT - LIMITED WARRANTY (Canada)

Panasonic Canada Inc. warrants this product to be free from defects in material and workmanship and agrees to remedy any such defect for a period as stated below from the date of original purchase.

Vacuum Cleaner - One (1) year, parts and labour

LIMITATIONS AND EXCLUSIONS

This warranty does not apply to products purchased outside Canada or to any product which has been improperly installed, subjected to usage for which the product was not designed, misused or abused, damaged during shipping, or which has been altered or repaired in any way that affects the reliability or detracts from the performance, nor does it cover any product which is used commercially. Parts such as disposable dust bags, filters, belts, light bulbs and agitator brushes are also excluded from coverage under this warranty.

This warranty is extended to the original end user purchaser only. A purchase receipt or other proof of date of original purchase is required before warranty service is performed.

THIS EXPRESS, LIMITED WARRANTY IS IN LIEU OF ALL OTHER WARRANTIES, EXPRESS OR IMPLIED, EXCLUDING ANY IMPLIED WARRANTIES OF MERCHANTABILITY OR FITNESS FOR A PARTICULAR PURPOSE. IN NO EVENT WILL PANASONIC CANADA INC. BE LIABLE FOR ANY SPECIAL, INDIRECT OR CONSEQUENTIAL DAMAGES.

In certain instances, some jurisdictions do not allow the exclusion or limitation of incidental or consequential damages, or the exclusion of implied warranties, so the above limitations and exclusions may not be applicable.

WARRANTY SERVICE

For product operation and information assistance, please contact your Dealer or our Customer Care Centre at:
Telephone #: (905) 624-5505 Fax #: (905) 238-2360 Web: www.panasonic.ca

For product repairs, please contact one of the following:

- Your Dealer who will inform you of an authorized Servicentre nearest you.
- Our Customer Care Centre at (905) 624-5505 or www.panasonic.ca
- A Panasonic Factory Servicentre listed below:

Richmond, British Columbia

Panasonic Canada Inc.
12111 Riverside Way
Richmond, BC V6W 1K8
Tel: (604) 278-4211
Fax: (604) 278-5627

Calgary, Alberta

Panasonic Canada Inc.
6835-8th St. N.E.
Calgary, AB T2E 7H7
Tel: (403) 295-3955
Fax: (403) 274-5493

Mississauga, Ontario

Panasonic Canada Inc.
5770 Ambler Dr.
Mississauga, ON L4W 2T3
Tel: (905) 624-8447
Fax: (905) 238-2418

Lachine, Québec

Panasonic Canada Inc.
3075, rue Louis A. Amos
Lachine, QC H8T 1C4
Tel: (514) 633-8684
Fax: (514) 633-8020

IF YOU SHIP THE PRODUCT TO A SERVICENTRE

Carefully pack and send prepaid, adequately insured and preferably in the original carton.
Include details of the defect claimed, and proof of date of original purchase.

Ref: VACwar05/01