

# Panasonic®

**COMMERCIAL VACUUM CLEANER**  
Aspirateur commercial  
*Commercial aspiradora*

## **MC-V5110** **Operating Instructions** Manuel d'utilisation *Instrucciones de operación*

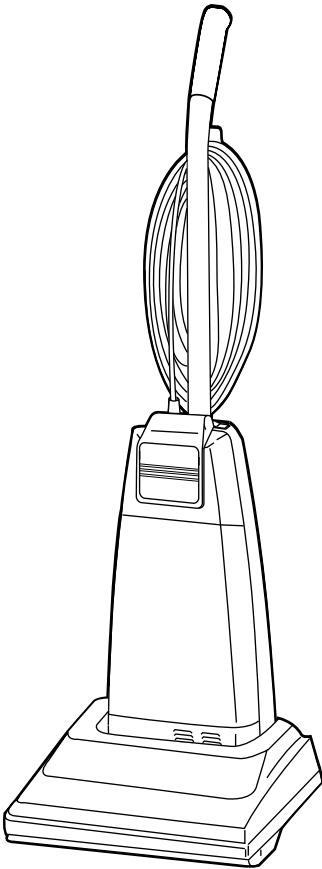

**Before operating your vacuum cleaner, please read these instructions completely.**

Avant d'utiliser l'appareil, il est recommandé de lire attentivement ce manuel.

*Antes de usar su aspiradora, lea completamente estas instrucciones por favor.*

C01ZCDL00000

# CONSUMER INFORMATION

Please read **IMPORTANT SAFETY INSTRUCTIONS** on page 5 before use. Read and understand all instructions.

## TO OUR VALUED CUSTOMER

We are very pleased to welcome you to the Panasonic family of products. Thank you for purchasing this product. Our intent is that you become one of our many satisfied customers.

**Proper assembly and safe use of your vacuum cleaner are your responsibilities. Your vacuum cleaner is intended for commercial use. The cleaner should be stored in a dry, indoor area. Read the Operating Instructions carefully for important use and safety information.**

**Special care is required when vacuuming certain types of carpet or floor covering. Always check the carpet or floor covering manufacturer's recommended cleaning instructions before vacuuming.**

## PLEASE PAY CLOSE ATTENTION TO ALL WARNING AND CAUTION STATEMENTS.



### WARNING

**WARNING** statements are designed to alert you to the possibility of personal injury, loss of human life, and/or damage to the vacuum cleaner and/or personal property if the instructions given are not followed.



### CAUTION

**CAUTION** statements are designed to alert you to the possibility of damage to the vacuum cleaner and/or personal property if the instructions given are not followed.



### WARNING

#### TO AVOID ELECTRICAL SHOCK

Never vacuum damp or wet surfaces or liquids.  
DO NOT store machine outdoors.  
Replace worn or frayed power cord immediately.  
Unplug from outlet when not in use and before servicing.

#### TO AVOID ACCIDENTS

Except for hand-held cleaners, keep machine on floor - not chairs, tables, steps, stairs, etc.  
Store machine promptly after each use to prevent accidents such as tripping over power cord or machine.  
Use machine and accessories only in a manner intended by the manufacturer.  
The use of an extension cord is not recommended.

# IMPORTANT SAFETY INSTRUCTIONS

When using vacuum cleaner, basic precautions should always be followed, including the following:

## READ ALL INSTRUCTIONS BEFORE USING THIS VACUUM CLEANER



## WARNING

To reduce the risk of fire, electrical shock, injury:

1. **DO NOT** leave vacuum cleaner when plugged in. Unplug from outlet when not in use and before servicing.
2. To reduce the risk of fire or electric shock - **DO NOT** use outdoors or on wet surfaces.
3. **DO NOT** allow to be used as a toy. Close attention is necessary when used by or near children.
4. Use only as described in this manual. Use only manufacturer's recommended tools.
5. **DO NOT** use with damaged cord or plug. If vacuum cleaner is not working as it should, has been dropped, damaged, left outdoors, or dropped into water, return it to an authorized Panasonic Servicenter.
6. **DO NOT** pull or carry by cord, use cord as a handle, close door on cord, or pull cord around sharp edges or corners. **DO NOT** run vacuum cleaner over cord. Keep cord away from heated surfaces.
7. **DO NOT** unplug by pulling on cord. To unplug, grasp the plug, not the cord.
8. **DO NOT** handle plug or vacuum cleaner with wet hands.
9. **DO NOT** put any objects into openings. **DO NOT** use with any opening blocked; keep free of dust, lint, hair, and anything that may reduce air flow.
10. Keep hair, loose clothing, fingers, and all parts of body away from openings and moving parts.
11. **DO NOT** pick up anything that is burning or smoking, such as cigarettes, matches, or hot ashes.
12. **DO NOT** use without dust bag and/or filters in place.
13. Turn off all controls before unplugging.
14. Use extra care when cleaning on stairs.
15. **DO NOT** use cleaner to pick up flammable or combustible liquids such as gasoline or use in areas where they may be present.
16. **DO NOT** operate cleaner without belt cover properly installed.

## SAVE THESE INSTRUCTIONS

**Note:** Before you plug in your commercial vacuum cleaner, make sure that the voltage indicated on the rating plate located at the back of the vacuum cleaner is the same as your local supply.

## TABLE OF CONTENTS

CONSUMER INFORMATION .....	2
IMPORTANT SAFETY INSTRUCTIONS .....	5
GROUNDING INSTRUCTIONS .....	10
PARTS IDENTIFICATION .....	12
FEATURE CHART .....	13
ASSEMBLY .....	14
Attaching Handle .....	14
FEATURES .....	16
Automatic Self Adjusting Nozzle .....	16
Edge Cleaning .....	16
Motor Protector .....	16
TO OPERATE CLEANER .....	18
ON-OFF Switch .....	18
Handle Adjustments .....	18
ROUTINE CARE OF CLEANER .....	20
Replacing Secondary Foam Filter .....	20
Changing Dust Bag .....	22
Removing and Installing Lower Plate .....	24
Replacing Belt .....	26
Cleaning Agitator .....	28
Replacing Agitator .....	28
Agitator Assembly .....	28
Removing Clogs .....	30
BEFORE REQUESTING SERVICE .....	32
WARRANTY .....	36,38
WHAT TO DO WHEN SERVICE IS NEEDED .....	40

# GROUNDING INSTRUCTIONS

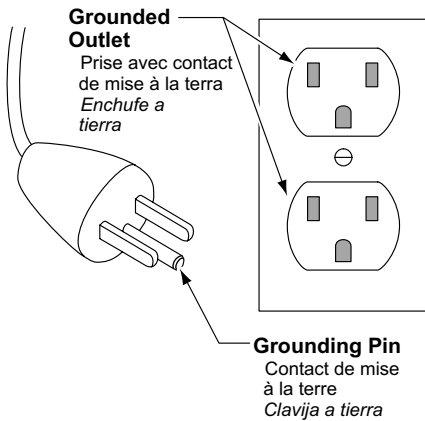

**Figure A**

This vacuum cleaner must be grounded. If it should malfunction or breakdown, grounding provides a path of least resistance for electric current to reduce the risk of electric shock. This vacuum cleaner is equipped with a cord having an equipment-grounding conductor and grounding plug. The plug must be plugged into an appropriate outlet that is properly installed and grounded in accordance with all local codes and ordinances.



## **DANGER**

Improper connection of the equipment-grounding conductor can result in a risk of electric shock. Check with a qualified electrician or service person if you are in doubt as to whether the outlet is properly grounded. Do not modify the plug provided with the vacuum cleaner – if it will not fit the outlet, have a proper outlet installed by a qualified electrician.

This vacuum cleaner is for use on a nominal 120-volt circuit, and has a grounding plug that looks like the plug illustrated in **Figure A**. Make sure that this vacuum cleaner is connected to an outlet having the same configuration as the plug.

No adapter should be used with this vacuum cleaner.

**Note:** Before you plug in your commercial vacuum cleaner, make sure that the voltage indicated on the rating plate located at the back of the vacuum cleaner is the same as your local supply.

# PARTS IDENTIFICATION

*Identificación de piezas*

*Nomenclature*

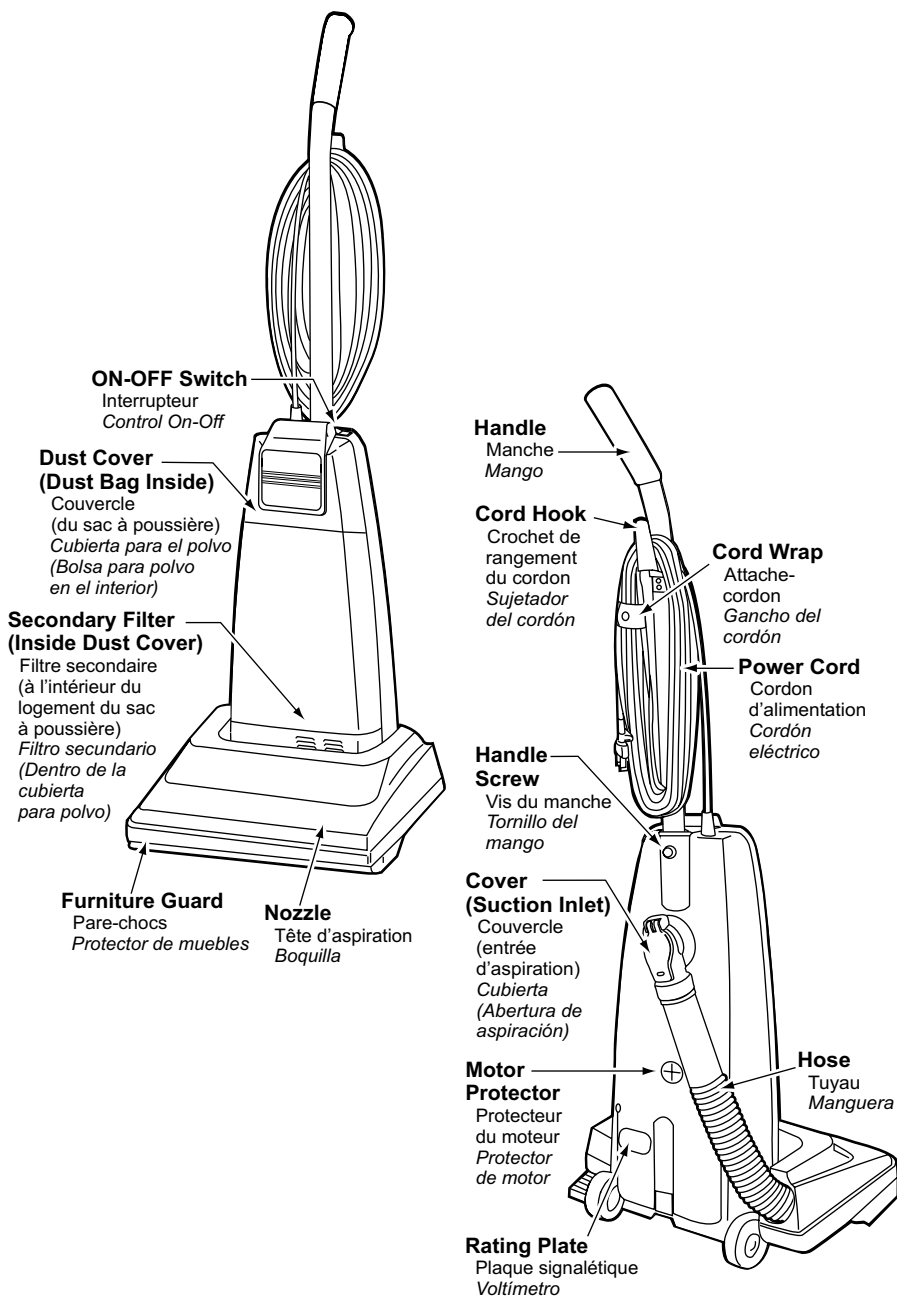

## FEATURE CHART

Power	Motor Protector	Height Adjust	Cord Length
120V AC (60Hz)	Yes	Auto	50 Ft. (15.25m)

## Tableau des caractéristiques

Alimentation	Protecteur du moteur	Réglage de la hauteur des brosses	Cordon d'alimentation
120 V c.a. (60 Hz)	Oui	Auto	15,25 m (50 pi)

## Diagrama de características

<i>Voltaje</i>	<i>Protector de motor</i>	<i>Adjust de nivel</i>	<i>Extensión de cordón</i>
120V AC (60Hz)	<i>Si</i>	<i>Auto</i>	<i>15,25 m (50 pi)</i>

# ASSEMBLY

## Attaching Handle

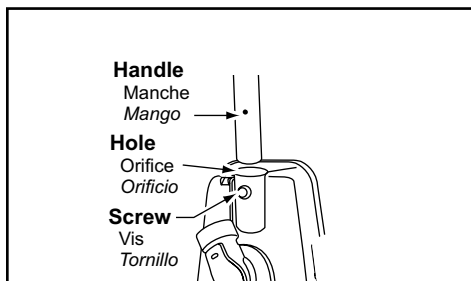

- 1)
  - **DO NOT** plug in until assembly is complete.
  - Remove handle screw.
  - Insert handle.

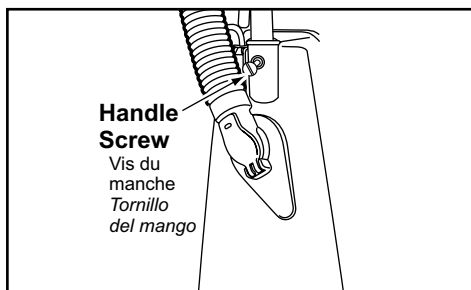

- 2)
  - Insert screw.
  - Tighten screw.

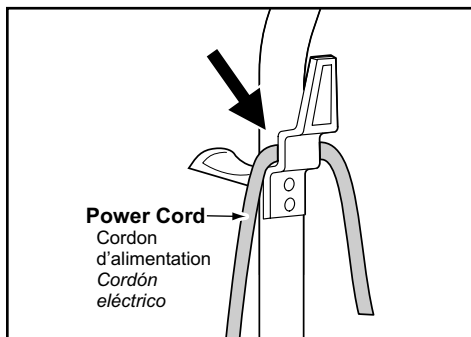

- 3)
  - Push power cord into cord clip.

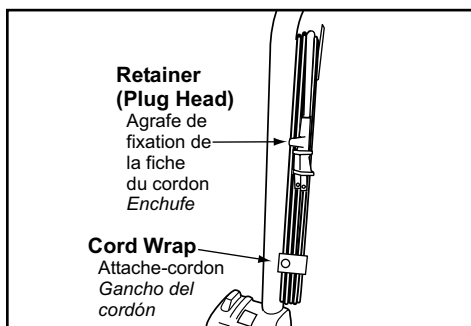

- 4)
  - Wrap power cord around cord hook.
  - Secure retainer (plug head) to power cord.



## FEATURES

### Automatic Self Adjusting Nozzle

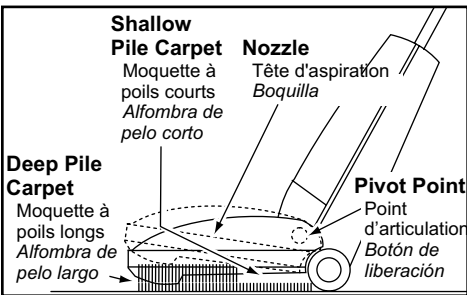

- The nozzle of your upright vacuum cleaner automatically adjusts to any carpet pile height.
- Feature allows nozzle to float evenly over carpet pile surfaces.
- No manual adjustments required.

### Edge Cleaning

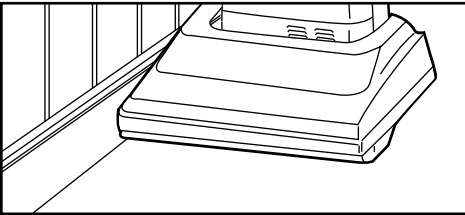

- Edge cleaning feature enables improved cleaning of carpets near walls and furniture.

### Motor Protector

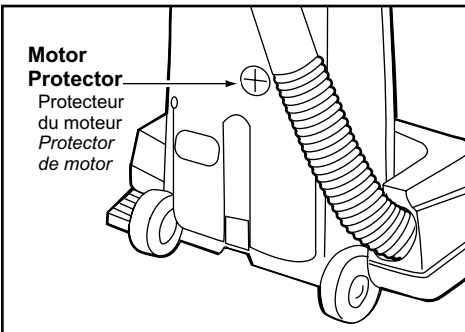

- Automatically opens to provide cooling air to the motor when a clog occurs or when dust bag needs changing.
- Motor protector may open when using tools.
- If motor protector opens, the vacuum will make a slightly different sound.

**Note:** Do not block motor protector.

## TO OPERATE CLEANER

### ON-OFF Switch

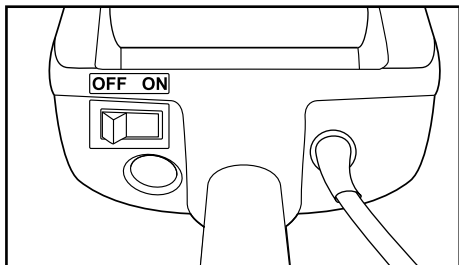

- Ensure ON-OFF switch is OFF.
- Plug the power cord into 120V outlet.
- ON position turns vacuum on.
- OFF position turns vacuum off.

### Handle Adjustments

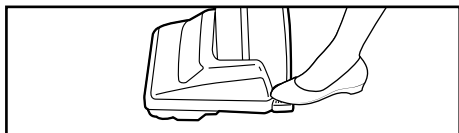

1)

- Step on handle release pedal to change handle position.

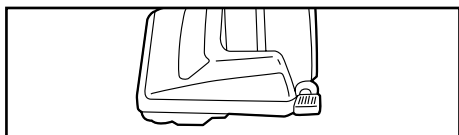

2)

- Move vacuum to upright position for storage and tool use.

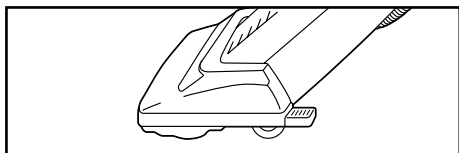

3)

- Move vacuum to middle position for normal use.

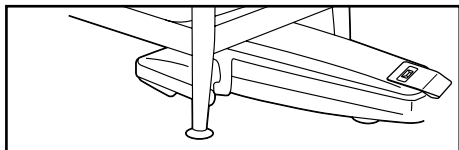

4)

- Use low position for cleaning under furniture.

## ROUTINE CARE OF CLEANER

Performing the following tasks will keep your new Panasonic vacuum cleaner operating at peak performance levels and will ensure these high levels for years to come. Check the **BEFORE REQUESTING SERVICE** section in this manual for recommendations on performing some of these tasks to help solve various problems that may occur.

### Replacing Secondary HEPA Filter

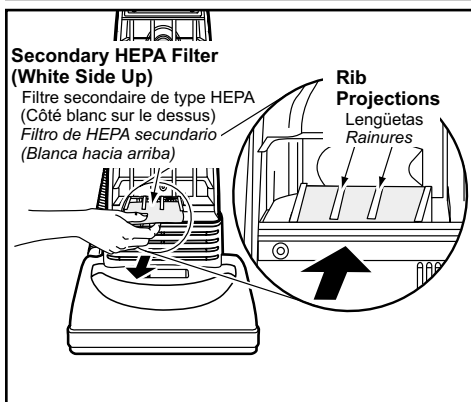

- Secondary HEPA filter protects the motor.
- Check filter when installing a new dust bag.
- If dirty, pull filter from bottom of dust compartment and replace.
- Place new filter, white side up, in dust compartment, **DO NOT CLEAN WITH WATER\***.
- Ensure filter is fully inserted under plastic rib projections.

\*Filter cannot be cleaned and should be replaced at least once each year.

## Changing Dust Bag

Always operate vacuum with genuine Type U3 Standard or U6 Electrostatic dust bags installed. Panasonic dust bags may be purchased through any authorized Panasonic dealer or ordered from service company.

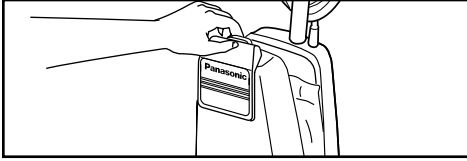

1)

- Pull outward on dust cover grip to remove the dust cover.

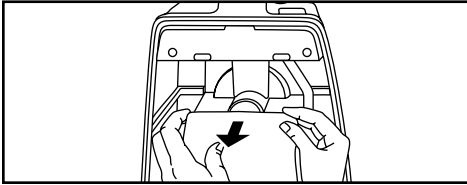

2)

- Remove dust bag by grasping cardboard portion and pulling out.

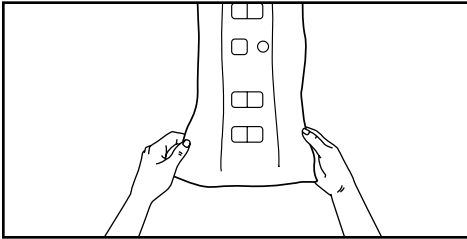

3)

- Spread out new dust bag, taking care not to tear bag.

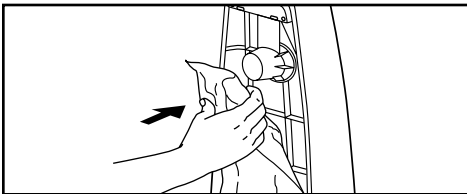

4)

- Attach new dust bag onto bag holder by holding cardboard portion and pushing back.

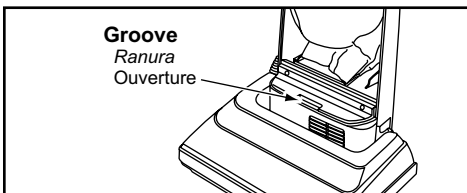

5)

- Reinsert tab on end of dust cover into groove on dust compartment to allow cover to rotate closed.

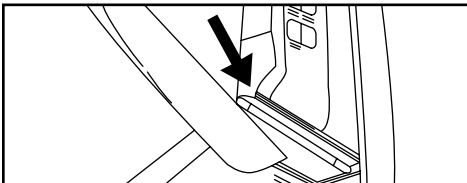

6)

- Rotate dust cover up into closed position and press into place without pinching dust bag.



## **WARNING** *Electrical Shock or Personal Injury Hazard*

*Disconnect the electrical supply before servicing or cleaning the unit. Failure to do so could result in electrical shock or personal injury from cleaner suddenly starting.*

### **Removing and Installing Lower Plate**

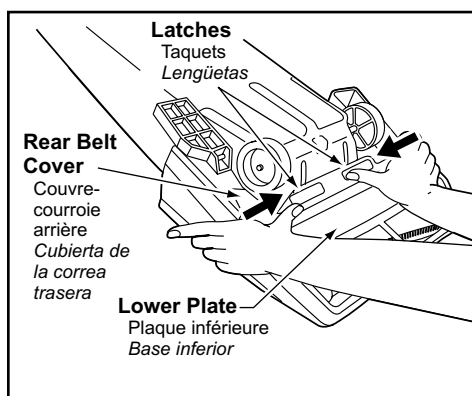

- Always place paper under nozzle whenever lower plate is removed to protect floor.
- Place handle in upright position and turn vacuum over to expose lower plate.
- Release lower plate by pressing two (2) latches inward as shown.
- Remove lower plate and remove any residue that may exist in belt area.
- Reinstall lower plate by hooking front end of lower plate into slots on front of nozzle housing.
- Make sure all wires are routed properly and not pinched.
- Press lower plate into place then push two (2) latches outward.

## Replacing Belt

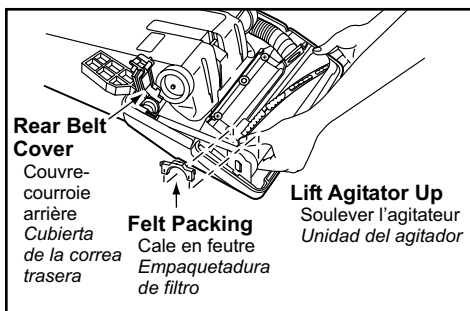

- Replace belt whenever a burning rubber smell caused by excessive slippage occurs.
- Remove lower plate.
- Lift rear belt cover and remove felt packing.
- Remove agitator by carefully lifting out.

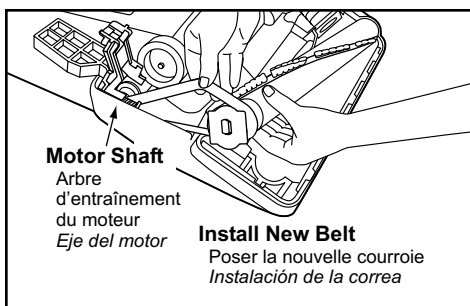

- Remove worn or broken belt.
- Clean agitator.
- Loop new belt (Type UB8 only) around motor shaft and agitator pulley; see illustration for correct belt routing.
- Reinstall agitator back into nozzle housing grooves.

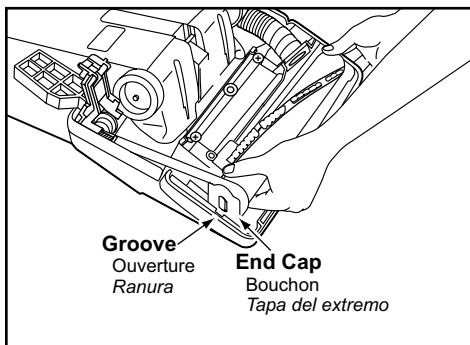

- Close rear belt cover and reinstall felt packing.
- After reinstalling the agitator, turn it by hand to make sure that belt is not twisted or pinched and that all rotating parts turn freely.
- Reinstall lower plate.

## Cleaning Agitator

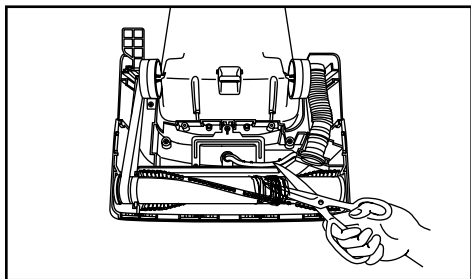

- Clean agitator after every five uses and every time the belt is replaced.
- Remove lower plate.
- Cut off any carpet pile and lint entangled around agitator with a pair of scissors.
- Remove agitator.
- Remove any string or debris located on the end caps, washers or agitator shaft.
- Reinstall agitator and lower plate.

## Replacing Agitator

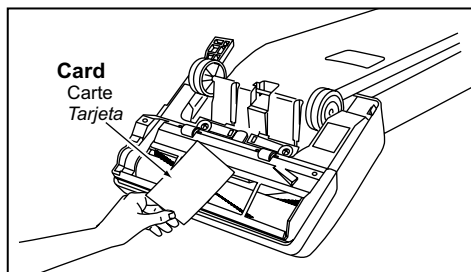

- When the bristles on the agitator are worn so that they do not touch a card held across the lower plate, the agitator should be replaced.
- Remove lower plate and agitator.
- Position belt over belt pulley on the new brush unit.
- Reinstall agitator and lower plate.

## Agitator Assembly

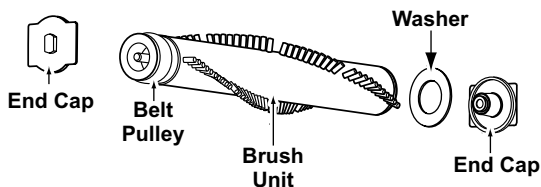

## Removing Clogs

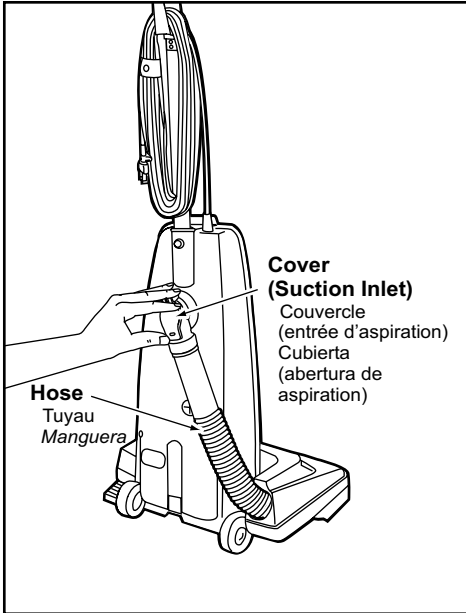

The hose located on the back of the vacuum cleaner carries the dirt from the nozzle up to the dust bag. If the hose should become clogged:

- Unplug vacuum.
- Pull open suction inlet cover and check for clogging.
- Remove lower plate.
- Remove hose from nozzle by lifting straight up.
- Inspect hose end and clear any obstructions.
- Reinstall hose and lower plate.

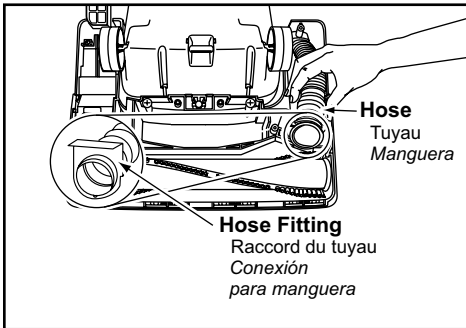



# BEFORE REQUESTING SERVICE



## **WARNING**

*Electric Shock or Personal Injury Hazard.*

*Disconnect the electrical supply before servicing or cleaning the unit. Failure to do so could result in electric shock or personal injury from cleaner suddenly starting.*

Review this chart to find do-it-yourself solutions for minor performance problems. Any service needed, other than those described in these Operating Instructions, should be performed by an authorized service representative.

<b>PROBLEM</b>	<b>POSSIBLE CAUSE</b>	<b>POSSIBLE SOLUTION</b>
<b>Cleaner will not run.</b>	<ol style="list-style-type: none"><li>1. Unplugged at wall outlet.</li><li>2. ON-OFF switch not turned on.</li><li>3. Tripped circuit breaker/blown fuse at household service panel.</li></ol>	<ol style="list-style-type: none"><li>1. Plug in firmly. Push ON-OFF switch to On.</li><li>2. Push ON-OFF switch to ON.</li><li>3. Reset circuit breaker or replace fuse.</li></ol>
<b>Poor job of dirt pickup.</b>	<ol style="list-style-type: none"><li>1. Full or clogged dust bag.</li><li>2. Broken belt.</li><li>3. Clogged hose or nozzle.</li><li>4. Hose not inserted fully.</li><li>5. Worn agitator.</li><li>6. Hole in hose.</li><li>7. Dust cover improperly installed.</li></ol>	<ol style="list-style-type: none"><li>1. Change bag.</li><li>2. Replace belt.</li><li>3. Clean hose or nozzle area.</li><li>4. Insert hose.</li><li>5. Replace agitator.</li><li>6. Replace hose.</li><li>7. Properly install dust cover.</li></ol>
<b>Dust escapes the paper bag.</b>	<ol style="list-style-type: none"><li>1. Bag improperly installed.</li><li>2. Bag torn.</li></ol>	<ol style="list-style-type: none"><li>1. Properly install bag.</li><li>2. Replace bag.</li></ol>

# WARRANTY

## Panasonic Commercial Vacuum Cleaner Limited Warranty

Panasonic Home and Commercial Products Company (referred to as "the warrantor") will repair this product with new or refurbished parts free of charge, in the U.S.A. or Puerto Rico, for one (1) year from the date of original purchase, in the event of a defect in materials or workmanship.

**This Limited Warranty Excludes both Labor and Parts for the following items:** disposable dust bags, filters, belts, light bulbs, agitator brushes and batteries (if supplied).

Carry-in or mail-in service in the U.S.A. can be obtained during the warranty period by contacting a Panasonic Services Company (PASC) Factory Servicenter listed in the Servicenter Directory, or by calling toll free, 1-888-350-9590, or by contacting your selling distributor. Carry-in or mail-in service in Puerto Rico can be obtained during the warranty period by calling the local Panasonic Sales Company telephone number listed in the Servicenter Directory.

This warranty is extended only to the original purchaser. A purchase receipt or other proof of date of original purchase will be required before warranty performance is rendered.

This warranty only covers failures due to defects in materials and workmanship which occur during normal use and does not cover damages which occur in shipment, or failures which are caused by products not supplied by the warrantor, or failures which result from accident, misuse, abuse, neglect, mishandling, misapplication, faulty installation, improper operation or maintenance, alteration, modification, power line surge, improper voltage supply, lightning damage, or service by anyone other than a Panasonic Authorized Servicenter, or damage that is attributable to acts of God.

### **LIMITS AND EXCLUSIONS:**

There are no express warranties except as listed above.

THE WARRANTOR SHALL NOT BE LIABLE FOR INCIDENTAL OR CONSEQUENTIAL DAMAGES RESULTING FROM THE USE OF THIS PRODUCT, OR ARISING OUT OF ANY BREACH OF THIS WARRANTY. ALL EXPRESS AND IMPLIED WARRANTIES, INCLUDING THE WARRANTIES OF MERCHANTABILITY AND FITNESS FOR A PARTICULAR PURPOSE, ARE LIMITED TO THE APPLICABLE WARRANTY PERIOD SET FORTH ABOVE.

Some states do not allow the exclusion or limitation of incidental or consequential damages, or limitations on how long an implied warranty lasts, so the above exclusions or limitations may not apply to you.

This warranty gives you specific legal rights and you may also have other rights which vary from state to state. If a problem with this product develops during or after the warranty period, you may contact your dealer or Servicenter. If the problem is not handled to your satisfaction, then write to the Customer Satisfaction Center at the listed address on the back cover.