

EXPLODED VIEW (NOZZLE HOUSING)... [A] BLOCK

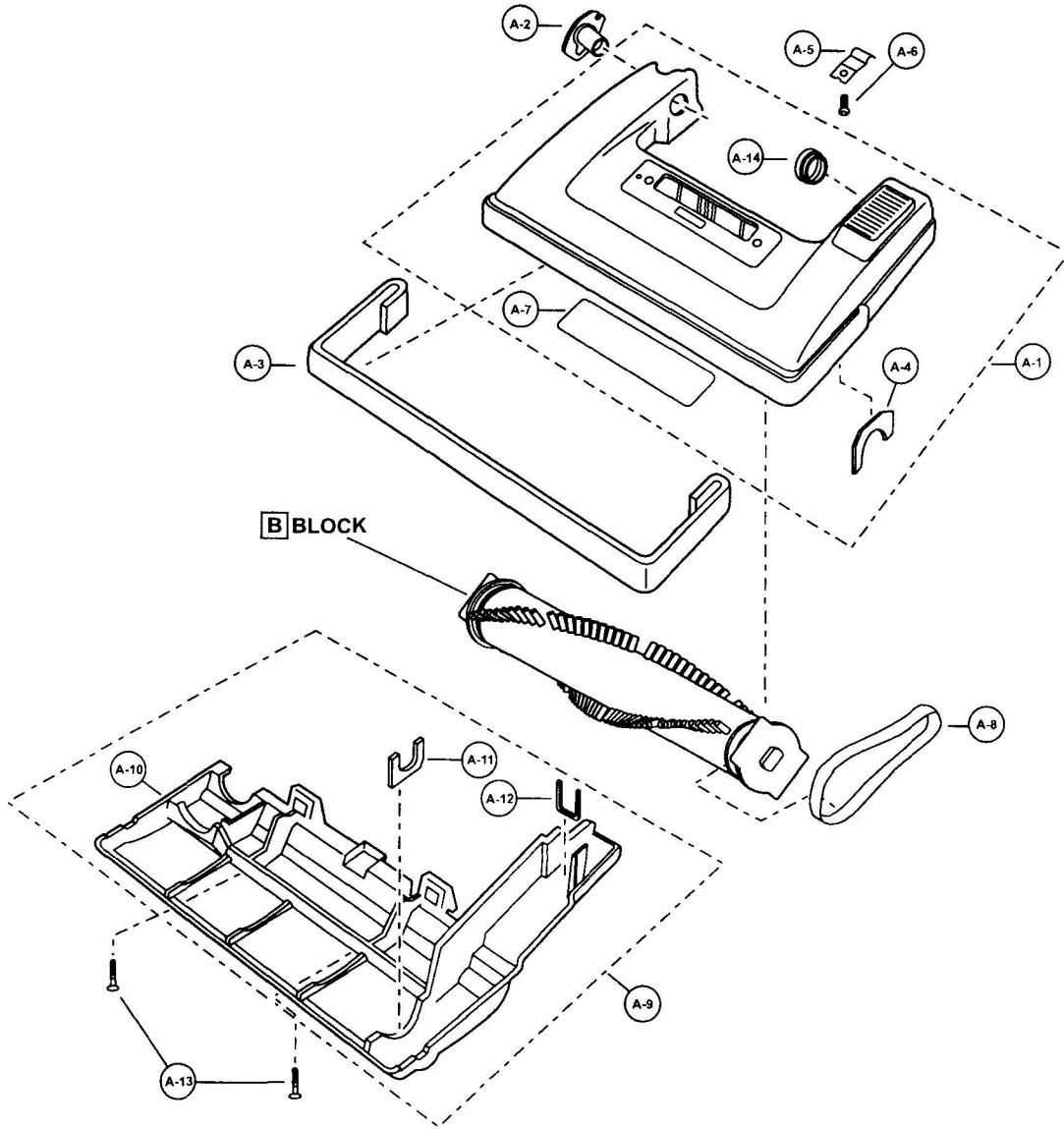

PARTS LIST (NOZZLE HOUSING)... [A] BLOCK

Ref. No.	Part Name & Description	Part No.	Quantity	Remarks
A - 1	Nozzle Housing	AC01AARRZUU1	1	
A - 2	Shaft (Plastic)	AMC25S-V00	1	
A - 3	Furniture Guard	AC10AV0ZV07	1	<i>P-</i>
A - 4	Packing (Nozzle)	AMC81A-V00	1	
A - 5	Spring (Pedal)	AMC57A-VOO	1	
A - 6	Screw (Pedal Spring)	AXTN4+16BFY	1	
A - 7	Top Mark	AC02TARRZU01	1	
A - 8	Belt	AC28SJPZOO	1	
A - 9	Lower Plate Assembly	AC91AAGMZV07	1	<i>l(,6ol</i>
A - 10	Lower Plate	AC27AAGMZV07	1	
A - 11	Packing (Lower Plate)	AMC75A-VOO	1	
A - 12	Belt Cover (Rear)	AMC43S-VOO	1	
A - 13	Screw (Lower Plate)	AC68AZAZOO	2	
A - 14	Plastic Holder	AMC78N-VOO	1	

EXPLODED VIEW (AGITATOR ASSEMBLY)... **B** BLOCK

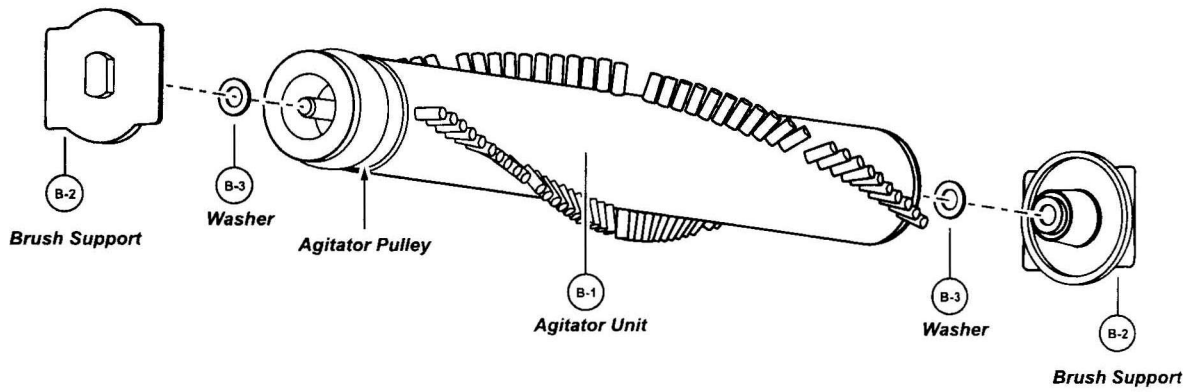

PARTS LIST (AGITATOR ASSEMBLY)... **B** BLOCK

Ref. No.	Part Name & Description	Part No.	Quantity	Remarks
B - 1	Agitator Unit	P-20065	1	
B - 2	Brush Support	AC96DZSZOU	2	
B - 3	Washer	AMC681-424	2	

• **EXPLODED VIEW (MOTOR HOUSING, MOTOR, HANDLE, AND BODY)..**
 \C\ BLOCK

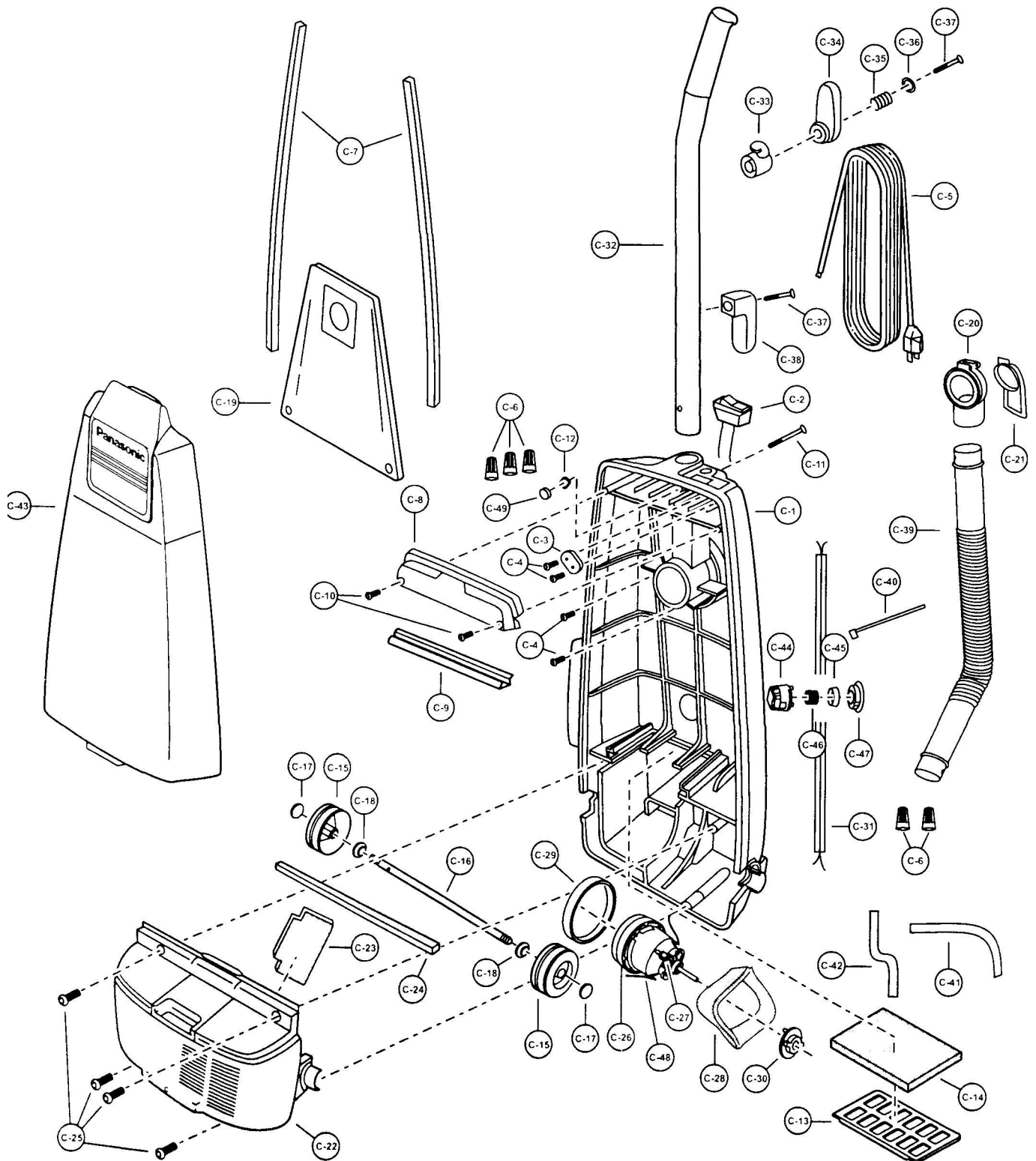

• PARTS LIST (MOTOR HOUSING, MOTOR, HANDLE, AND BODY)... [C] BLOCK

Ref. No.	Part Name & Description	Part No.	Quantity	rg	Remarks	^
C - 1	Dust Compartment Unit	AC40KBJYZV07	1	T^Cj/Includes C-41 and C-42 Packing		
C - 2	ON/OFF Switch	AMC98E-V010U	1			
C - 3	Cord Stopper	AMC62E-J20	1			
C - 4	Screw (Cord Stopper, Suction Inlet)	AXTN4+16BFY				
C - 5	Power Cord	AC97EAGMZV06	1			
C - 6	Wire Connector	AMC-1CTCE23				
C - 7	Packing (Dust Container)	AC66KV01V06				
C - 8	Switch Cover	AC03EV07V06	1			
C - 9	Packing (Switch Cover)	AC73KV0ZV06	1			
C - 10	Screw (Switch Cover)	AXTN4+16BFY				
C - 11	Handle Screw	AMC73B-V00	1			
C - 12	Nut (Handle Screw)	AMP21B-170	1			
C - 13	Filter Supporter	AMC32K-V00	1			
C - 14	Secondary Filter (Foam)	AMC37K-V00	1			
C - 15	Wheel	AMC01C-V00U				
C - 16	Shaft (Wheel)	AC16CUSZ00	1			
C - 17	Stopper (Wheel)	AC74SUSZ00				
C - 18	Washer (Wheel)	AXWG6E115FY				
C - 19	Dust Bag (Type U6)	AC16KJYZ00	1			
C - 20	Suction Inlet	AC60HF74VU6	1			
C - 21	Cover (Suction Inlet)	AMC02H-F70E	1			
C - 22	Motor Case	AC09FBJXZU01	1			
C - 23	Packing (Rear Cover)	AC02LBJYZ00	1			
C - 24	Packing (Motor Case)	AC19FJPZV06	1			
C - 25	Screw (Motor Case)	AXTN4+20BFY				
C - 26	Fan Motor Unit	AC92FBJYZ00	1			
C - 27	Carbon Brush	AMC27F-AV00U	1 (Set)			
C - 28	Noise Suppressor	AC99GAMMZ00	1			
C - 29	Motor Support (Front)	AMC02F-E00	1			
C - 30	Motor Support Rubber (Rear)	AMC03F-V00	1			
C - 31	Wire Cord	AMC37G-V020U	1			
C - 32	Handle	AMC64B-V2Z00	1			
C - 33	Cord Hook Base	AC55EV0ZV07	1			
C - 34	Upper Cord Storage Hook	AC53EV0ZV07	1			
C - 35	Spring (Cord Hook)	AMC76N-F70	1			
C - 36	Washer (Cord Storage Hook)	AMC58B-F70	1			
C - 37	Screw (Cord Storage Hook)	AXTN4+30BFY				
C - 38	Lower Cord Storage Hook	AC54EV0ZV07	1			
C - 39	Hose	AC34PV02V06	1			
C - 40	Wire Tie	AMC596-702	1			
C - 41	Packing (Right)	AC39AYUZV00	1			
C - 42	Packing (Left)	AC40AYUZV00	1			
C - 43	Dust Cover	AC60KKBZUU1	1			
C - 44	Protector Case	AC68KJMZV06	1			
C - 45	Protector	AC69KJMZV06	1			
C - 46	Protector Spring (Blue)	AC70KAHHZB00	1			
C - 47	Protector Supporter (Motor)	AC18MJMZV06	1			
C - 48	Lead Assembly	AC99WAJDZ00	1			
C - 49	Insulator Packing (Handle Screw)	AC61LAGMZ00	1			