

Panasonic®

VACUUM CLEANER

Aspirateur

Aspiradora

MC-V5485

Operating Instructions

Manuel d'utilisation

Instrucciones de operación

QUICKDRAW™
TOOLS-ON-BOARD WITH READY-TO-USE HOSE

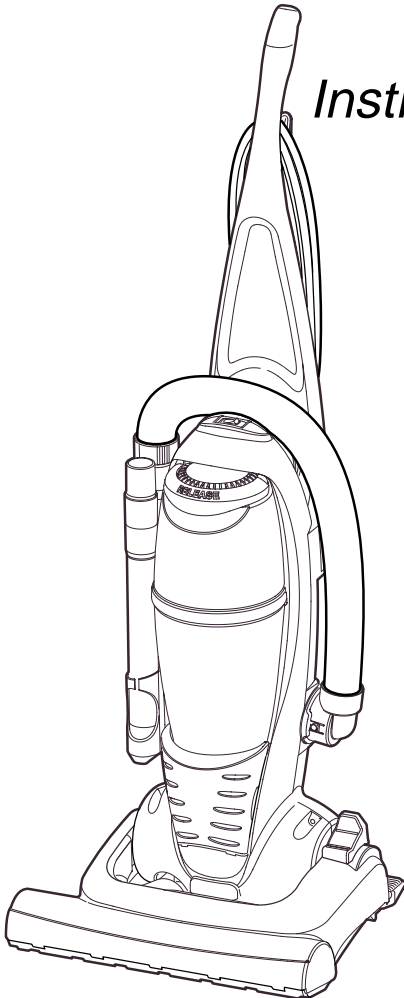

Before operating your vacuum cleaner, please read these instructions completely.

Avant d'utiliser l'appareil, il est recommandé de lire attentivement ce manuel.

Antes de usar su aspiradora, lea completamente estas instrucciones por favor.

CONSUMER INFORMATION

Please read **IMPORTANT SAFETY INSTRUCTIONS** on page 5 before use. Read and understand all instructions.

TO OUR VALUED CUSTOMER

We are very pleased to welcome you to the Panasonic family of products. Thank you for purchasing this product. Our intent is that you become one of our many satisfied customers.

Proper assembly and safe use of your vacuum cleaner are your responsibilities. Your vacuum cleaner is intended only for household use. The cleaner should be stored in a dry, indoor area. Read the Operating Instructions carefully for important use and safety information.

Special care is required when vacuuming certain types of carpet or floor covering. Always check the carpet or floor covering manufacturer's recommended cleaning instructions before vacuuming.

PLEASE PAY CLOSE ATTENTION TO ALL WARNING AND CAUTION STATEMENTS.

WARNING

WARNING statements are designed to alert you to the possibility of personal injury, loss of human life, and/or damage to the vacuum cleaner and/or personal property if the instructions given are not followed.

CAUTION

CAUTION statements are designed to alert you to the possibility of damage to the vacuum cleaner and/or personal property if the instructions given are not followed.

WARNING

TO AVOID ELECTRICAL SHOCK

Never vacuum damp or wet surfaces or liquids.
DO NOT store machine outdoors.
Replace worn or frayed power cord immediately.
Unplug from outlet when not in use and before servicing.

TO AVOID ACCIDENTS

Except for hand-held cleaners, keep machine on floor - not chairs, tables, steps, stairs, etc.
Store machine promptly after each use to prevent accidents such as tripping over power cord or machine.
Use machine and accessories only in a manner intended by the manufacturer.
The use of an extension cord is not recommended.

IMPORTANT SAFETY INSTRUCTIONS

When using vacuum cleaner, basic precautions should always be followed, including the following:

READ ALL INSTRUCTIONS BEFORE USING THIS VACUUM CLEANER

WARNING

To reduce the risk of fire, electrical shock, injury:

1. **DO NOT** leave vacuum cleaner plugged in. Unplug from outlet when not in use and before servicing.
2. To reduce the risk of fire or electric shock - **DO NOT** use outdoors or on wet surfaces.
3. **DO NOT** allow to be used as a toy. Close attention is necessary when used by or near children.
4. Use only as described in this manual. Use only manufacturer's recommended tools.
5. **DO NOT** use with damaged cord or plug. If vacuum cleaner is not working as it should, has been dropped, damaged, left outdoors, or dropped into water, return it to an authorized Panasonic Servicenter.
6. **DO NOT** pull or carry by cord, use cord as a handle, close door on cord, or pull cord around sharp edges or corners. **DO NOT** run vacuum cleaner over cord. Keep cord away from heated surfaces.
7. **DO NOT** unplug by pulling on cord. To unplug, grasp the plug, not the cord.
8. **DO NOT** handle plug or vacuum cleaner with wet hands.
9. **DO NOT** put any objects into openings. **DO NOT** use with any opening blocked; keep free of dust, lint, hair, and anything that may reduce air flow.
10. Keep hair, loose clothing, fingers, and all parts of body away from openings and moving parts.
11. **DO NOT** pick up anything that is burning or smoking, such as cigarettes, matches, or hot ashes.
12. **DO NOT** use without dust bin and/or dust bin filter in place.
13. Turn off all controls before unplugging.
14. Use extra care when cleaning on stairs.
15. **DO NOT** use cleaner to pick up flammable or combustible liquids such as gasoline or use in areas where they may be present.

SAVE THESE INSTRUCTIONS

THIS VACUUM CLEANER IS INTENDED FOR HOUSEHOLD USE ONLY

Note: Before you plug in your Panasonic vacuum cleaner, make sure that the voltage indicated on the rating plate located at the back of the vacuum cleaner is the same as your local supply.

TABLE OF CONTENTS

| | |
|--|------------|
| CONSUMER INFORMATION | 2 |
| IMPORTANT SAFETY INSTRUCTIONS | 5 |
| PARTS IDENTIFICATION | 10 |
| FEATURE CHART | 11 |
| GETTING STARTED | 12 |
| Using Handle | 12 |
| Cord Assembly | 14 |
| Using Cord Hook | 14 |
| Tool Storage | 14 |
| FEATURES | 16 |
| Automatic Self Adjusting Nozzle | 16 |
| Edge Cleaning | 16 |
| L-Shaped Nozzle | 16 |
| Thermal Protector | 18 |
| Motor Protector | 18 |
| TO OPERATE CLEANER | 20 |
| Power Cord | 20 |
| ON-OFF Switch | 20 |
| Carpet-Bare Floor Selector | 22 |
| Handle Adjustments | 24 |
| Using Tools | 26 |
| ROUTINE CARE OF CLEANER | 28 |
| Cleaning Secondary Filter Screen | 28 |
| Replacing HEPA Exhaust Filter | 30 |
| Dust Bin Assembly | 30 |
| Dust Bin Cleaning | 32 |
| Filter Removal and Cleaning | 34 |
| Filter Replacement | 36 |
| Replacing Headlight Bulb | 36 |
| Cleaning Agitator | 38 |
| Removing and Installing Lower Plate | 38 |
| Replacing Belt | 40 |
| Replacing Agitator | 40 |
| Agitator Assembly | 40 |
| Cleaning Exterior | 42 |
| Removing Clogs | 42 |
| BEFORE REQUESTING SERVICE | 44 |
| WARRANTY | 47, 48 |
| WHAT TO DO WHEN SERVICE IS NEEDED | back cover |

PARTS IDENTIFICATION

Nomenclature

Identificación de pieza

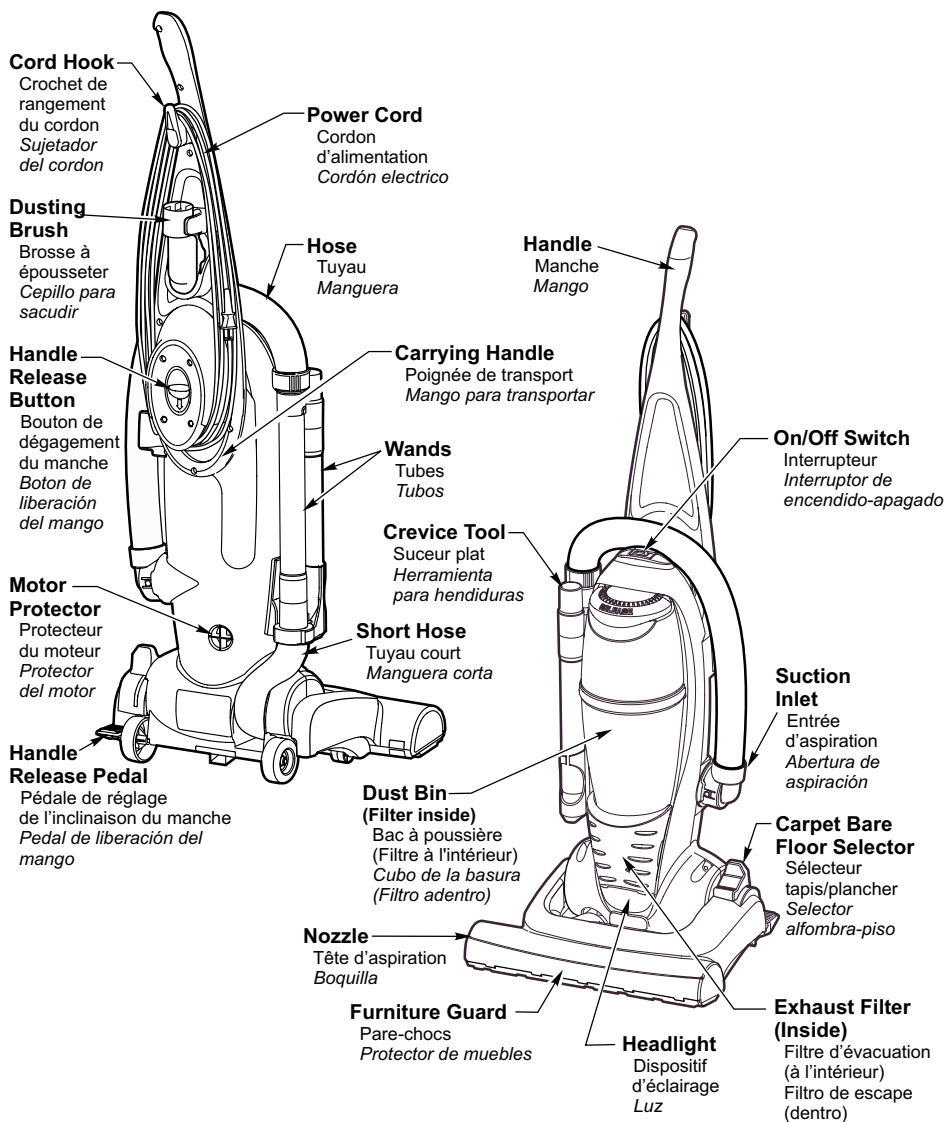

FEATURE CHART

| Power | Headlight | Cord Length | Bare Floor |
|-----------------|-----------|-------------|------------|
| 120V AC (60 Hz) | Yes | 30 Ft | Yes |

Tableau des caractéristiques

| Alimentation | Dispositif d'éclairage | Longueur du cordon | Position plancher |
|--------------------|------------------------|--------------------|-------------------|
| 120 V c.a. (60 Hz) | Oui | 9,1 m (30 pi) | Oui |

Diagrama de características

| <i>Voltaje</i> | <i>Luz</i> | <i>Medida del cordón</i> | <i>Uso sin alfombra</i> |
|--------------------------|------------|--------------------------|-------------------------|
| <i>120 V a.c (60 Hz)</i> | <i>Si</i> | <i>9,1 m (30 pi)</i> | <i>Si</i> |

GETTING STARTED

Using Handle

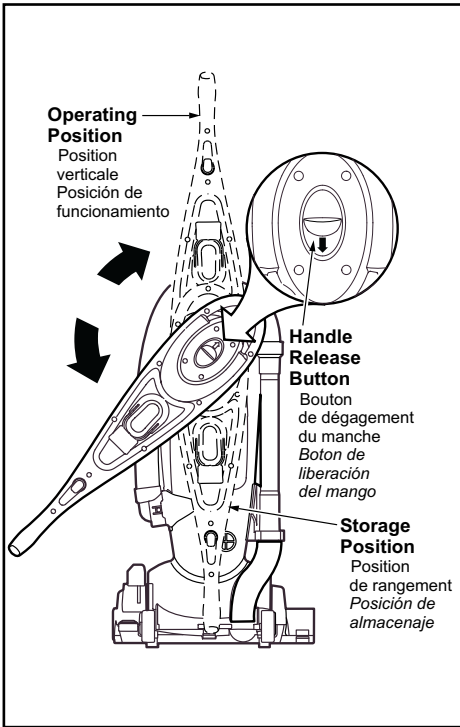

- To release handle; press handle release button as shown.
- With release button depressed rotate handle clockwise to the operating position. Once handle reaches the operating position (up) the handle will automatically lock into place.

Note: You should hear a noticeable “click” sound when handle reaches the operating position.

Note: Make sure the handle is locked in the operating position before using vacuum. **DO NOT** operate vacuum unless handle is locked.

- To rotate the handle to the storage position when vacuum is not in use, press handle release button and rotate handle counter-clockwise for easy storage.



Note: You should hear a noticeable “click” sound when handle reaches the storage position.

- **Never** pull the vacuum cleaner with the handle in the storage position. The handle will drag on the floor.
- Always lift the vacuum by the carrying handle when transporting to storage.

Cord Assembly

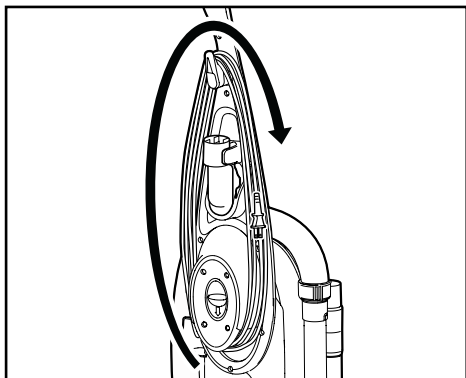

- Wrap power cord around cord hook.
- Secure retainer (plug head) to power cord.

Using Cord Hook

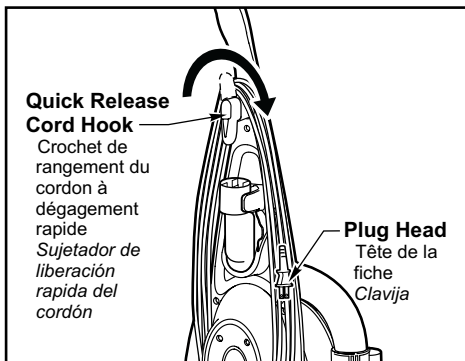

- Detach plug head from power cord.
- Rotate cord hook down to release cord.
- Return the cord hook to the upright position before attempting to rewind the cord.

Tool Storage

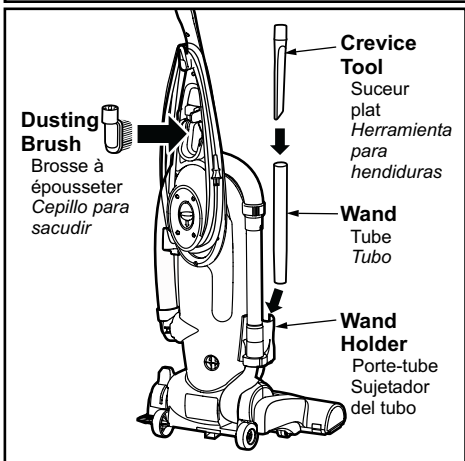

- Some tools may already be stored on vacuum cleaner.
- Place the dusting brush in the dusting brush holder on the back of the handle.
- Place the extension wand into the wand holder as shown.
- The crevice tool is placed inside the extension wand.
- The crevice tool can be stored in the wand holder when only wands are used.

FEATURES

Automatic Self Adjusting Nozzle

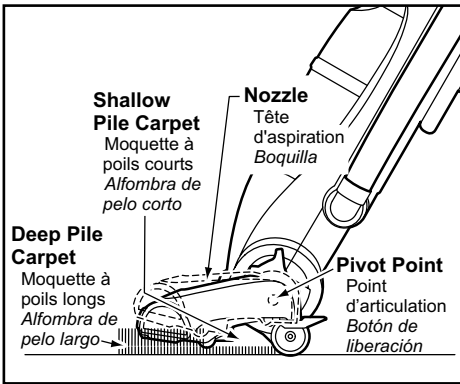

- The nozzle of your Panasonic upright vacuum cleaner automatically adjusts to any carpet pile height.
- No manual adjustments required.

Edge Cleaning

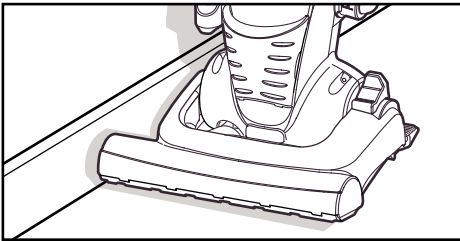

- Edge cleaning feature provides for improved cleaning of carpets near walls and furniture.

L-Shaped Nozzle

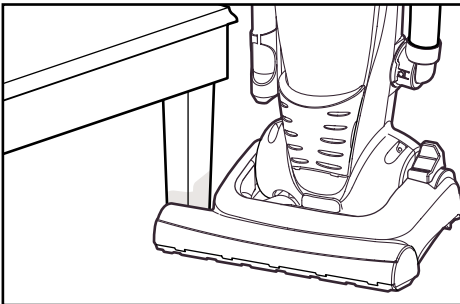

- The L-Shaped nozzle provides improved cleaning in and around furniture such as table legs.

Thermal Protector

- If a clog prevents the normal flow of air to the motor, the thermal protector turns the motor off automatically to allow the motor to cool in order to prevent possible damage to the vacuum.
- During this time the headlight remains on.
- To correct problem, turn off and unplug vacuum, remove clogs (see page 42), and/or clean/replace filters (see pages 28-30).
- Empty dust bin if necessary (see page 32).
- Wait approximately thirty (30) minutes, plug vacuum in, turn on to see if thermal protector has reset. Thermal protector will not reset if vacuum is not turned off even if vacuum cools down.

Motor Protector

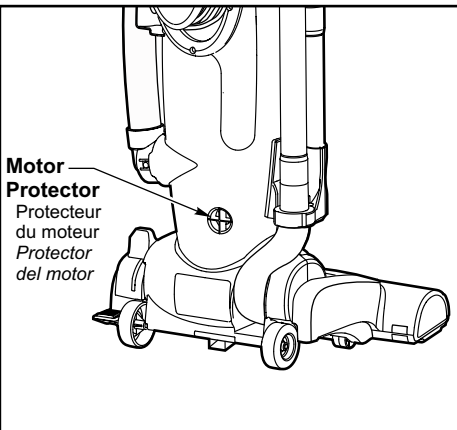

- Automatically opens to provide cooling air to the motor when a clog occurs or when dust bin needs changing.
- Motor protector may open when using tools.
- Check operation by placing hand over end of hose.
- If motor protector opens, the vacuum will make a slightly different sound.

Note: Do not block motor protector.

TO OPERATE CLEANER

Power Cord



WARNING

Electrical Shock or Personal Injury Hazard.

Disconnect the electrical supply before servicing or cleaning the unit. Failure to do so could result in electrical shock or personal injury from cleaner suddenly starting.

Note: To reduce the risk of electrical shock, this vacuum has a polarized plug, one blade is wider than the other. This plug will fit in a polarized outlet only one way. If the plug does not fit fully in the outlet, reverse the plug. If it still does not fit, contact a qualified electrician to install the proper outlet. **DO NOT CHANGE THE PLUG IN ANY WAY.** Only use outlets near the floor.

ON-OFF Switch

On-Off Switch
Interrupteur
Interruptor de
encendido-apagado

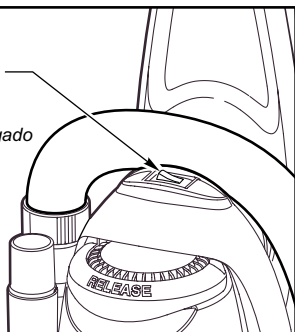

- Ensure ON-OFF switch is OFF.
- Plug the power cord into 120V outlet.
- ON position turns vacuum on.
- OFF position turns vacuum off.

Carpet-Bare Floor Selector

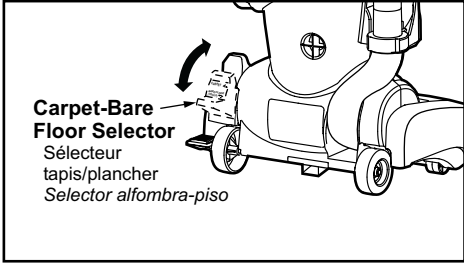

Carpet-Bare Floor Selector
Sélecteur tapis/plancher
Selector alfombra-piso

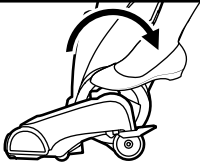

To Clean Bare Floor Or Use Tools
Position plancher ou avec accessoires
Para aspirar sobre un suelo
sin alfombra o usar los accesorios

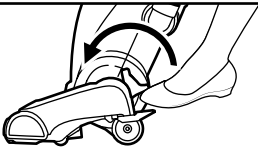

To Clean Carpet
Position tapis
Para aspirar sobre
una alfombra

- Selector should be placed in **BARE FLOOR (TOOLS)** position when using cleaner on bare floors and when using tools.
- The agitator does not rotate in the **BARE FLOOR (TOOLS)** position.
- Selector should be placed in **CARPET** position when using cleaner on carpeted floors.
- For longer belt life, turn vacuum off before moving selector.
- Otherwise, take care when selecting either position to ensure selector is pushed as fully and quickly as possible to desired position.
- Failure to do so can cause belt to rub on selector shaft and result in belt becoming hot and creating a burning rubber smell.

Handle Adjustments

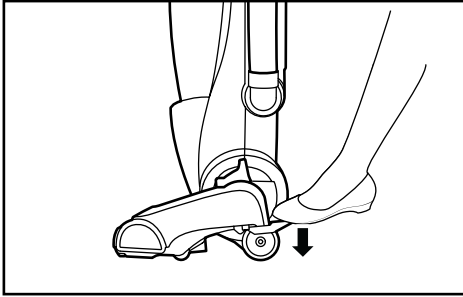

- Step on handle release pedal to change handle position.

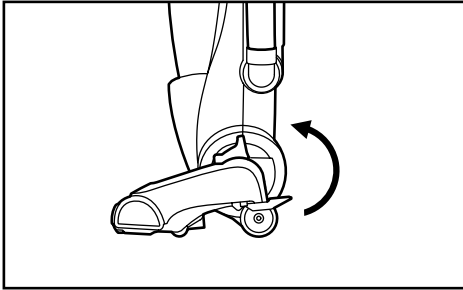

- Move vacuum to upright position for storage and tool use.

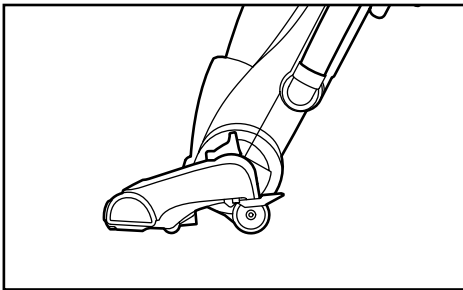

- Move vacuum to middle position for normal use.

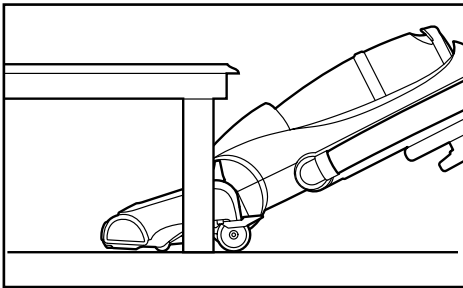

- Use low position for cleaning under furniture.

Using Tools

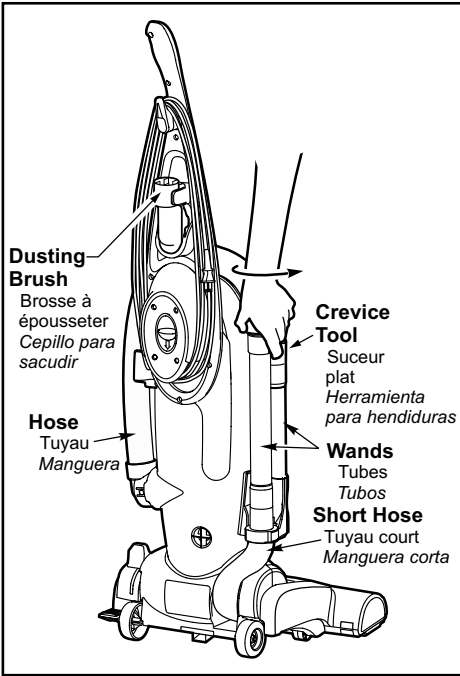

- **ALWAYS** place Carpet-Bare Floor selector in Bare Floor (tools) position when using tools.
- Remove wand from short hose by twisting and pulling up.
- The tools can be attached to hose, wand(s) or crevice tool.
- **DO NOT** overextend your reach with hose as it could tip vacuum.

Note: Handle should be placed in the storage position to help prevent tipping when using tools.

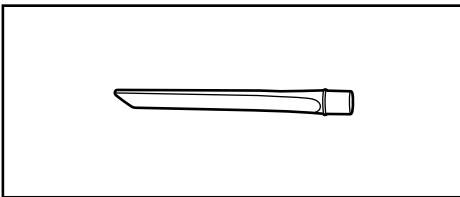

- The Crevice Tool may be used on the following items:
 - Furniture
 - Cushions
 - Drapes
 - Stairs
 - Walls

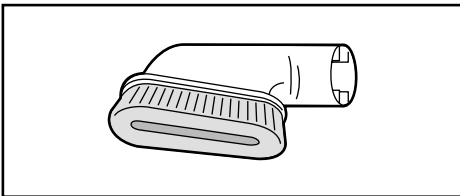

- The Dusting Brush may be used on the following items:
 - Furniture
 - Drapes
 - Stairs
 - Walls

Note: Always clean tools before using.

ROUTINE CARE OF CLEANER

Performing the following tasks will keep your new Panasonic vacuum cleaner operating at peak performance levels and will ensure these high levels for years to come. Check the **BEFORE REQUESTING SERVICE** section in this manual for recommendations on performing some of these tasks to help solve various problems that may occur.



WARNING

Electrical Shock or Personal Injury Hazard.

Disconnect the electrical supply before servicing or cleaning the unit. Failure to do so could result in electrical shock or personal injury from cleaner suddenly starting.

Cleaning Secondary Filter Screen

Secondary Filter Screen

Tamis filtrant
secondaire
Rejilla del
filtro secundario

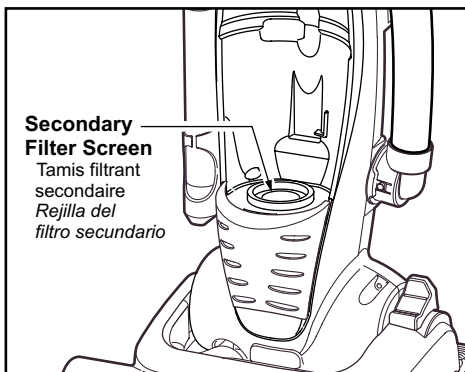

- The secondary filter screen protects the motor.
- Always check filter screen when cleaning dust bin.
- If dirty or clogged, remove debris from filter screen.

Replacing HEPA Exhaust Filter

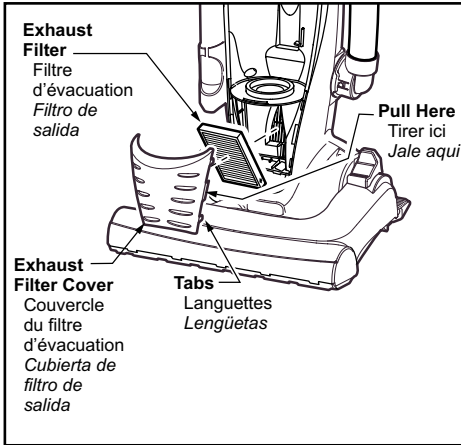

- The HEPA exhaust filter removes dirt from recirculated air.
 - Check filter after emptying dust bin. Replace when dirty.
 - To remove, pull out on both sides of the exhaust filter cover.
 - Grasp the exhaust filter and pull out to remove.
 - Ensure foam edge of the filter is facing towards the vacuum cleaner when placing filter into filter compartment. Push only on filter frame.
 - Reinstall exhaust filter cover by snapping into place.
- * Filter cannot be cleaned and should be replaced at least once each year.

Dust Bin Assembly

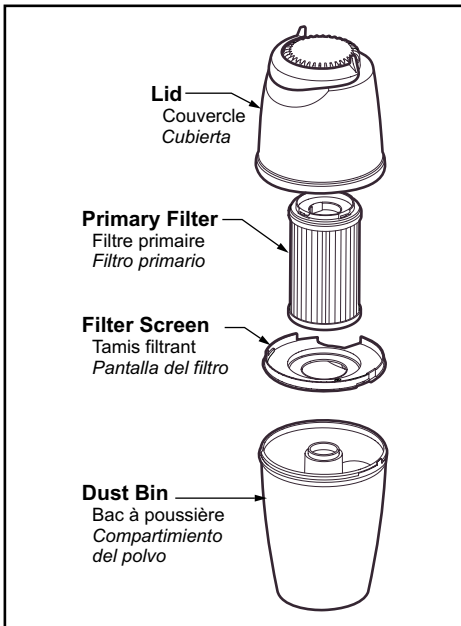

- Lid**
 - The Lid houses the primary filter.
- Primary Filter**
 - Filter traps dirt and debris picked up by the suction motor.
- Filter Screen**
 - The filter screen traps larger particles of dirt and debris, preventing them from reaching the filter.
- Dust Bin**
 - Captures dirt and debris picked up by the suction motor.

Dust Bin Cleaning

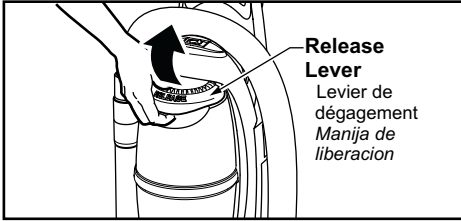

- 1) Remove dust bin assembly from cleaner by lifting the release lever as shown.



- 2) Remove dust bin from cleaner by tilting out as shown.

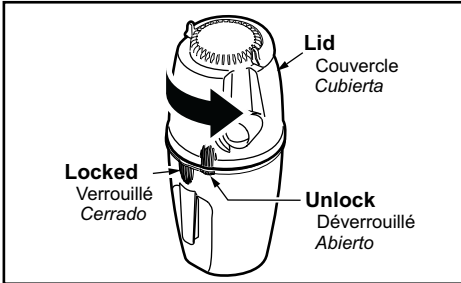

- 3) Rotate lid counter-clockwise from the locked position to the unlocked position as shown.

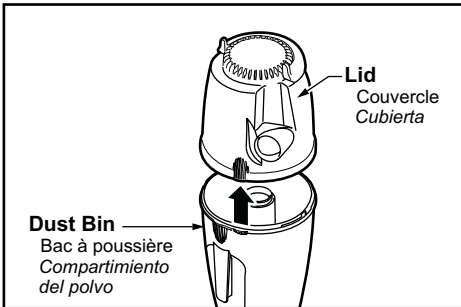

- 4) Separate the lid from the dust bin by lifting it straight off.

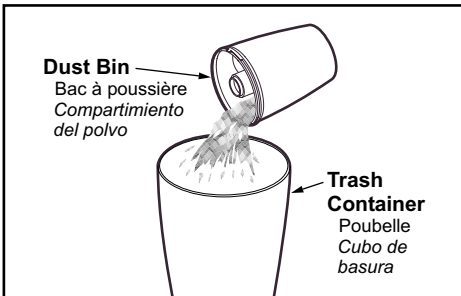

- 5) Empty contents of dust bin into a proper waste container.

Filter Removal and Cleaning

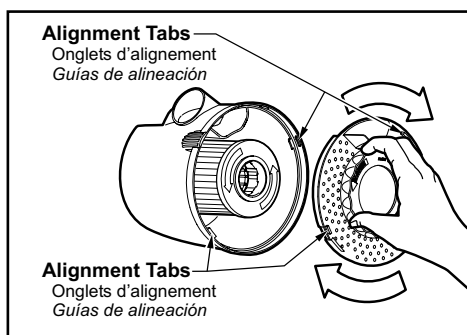
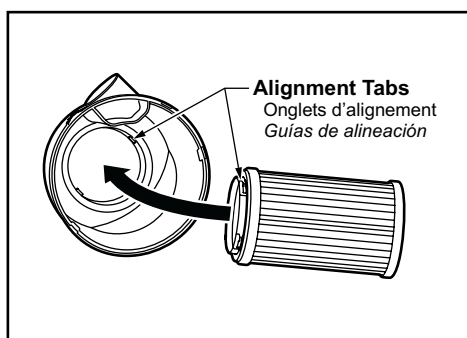
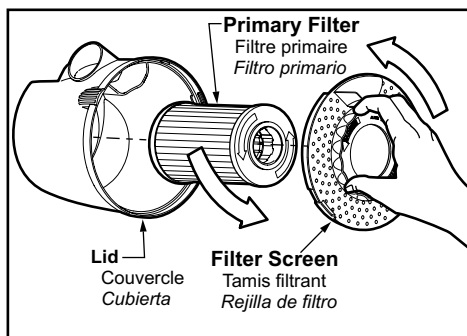

- Check primary filter frequently and clean when dirty.
- Remove the dust bin assembly as outlined in the DUST BIN CLEANING section and empty contents of dust bin.
- Make sure dust bin is empty before filter is removed.
- Grasp filter screen, rotate counter-clockwise and lift out.
- Grasp primary filter, rotate counter-clockwise and lift out.
- Clean primary filter by gently tapping it on a firm surface over a trash container. Tap on several sides to ensure best cleaning.
- The filter may be cleaned by rinsing it under a faucet. Rinse with water only, do not use detergent or soap.
- To maintain best performance, rinse filter exterior with water under a faucet every 6 months. Once the filter is rinsed clean, damp dry with a cloth and let air dry for 24 hours.
- When the cleaning of the filter no longer restores vacuum suction to full power you need to replace the filter. (page 36)
- To re-install the filter screen, align tabs on filter screen with tabs on lid. Rotate filter screen clockwise to lock in place.

Filter Replacement

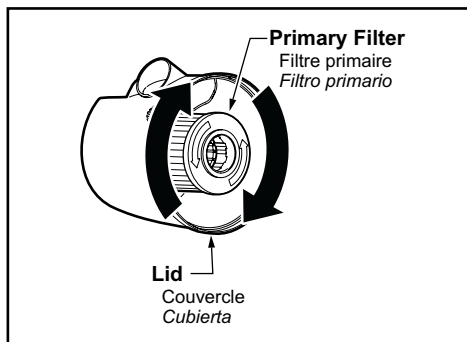

- Before replacing the filter it is a good idea to clean the inside of the dust bin and lid area.
- Rotate filter clockwise until slots lock onto tabs in lid.

Note: Under normal use and care, your filter can be expected to last up to 5 years.

Replacing Headlight Bulb

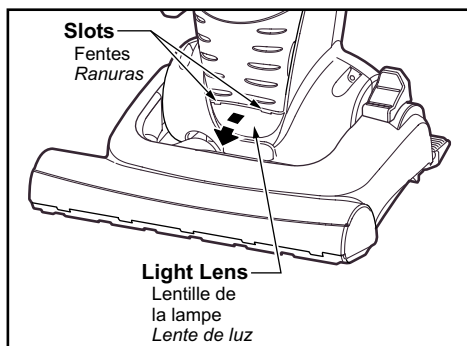

- Ensure ON-OFF switch is OFF.
- Disconnect power cord from electrical outlet.
- Press handle release pedal and rotate the handle down so the cleaner is laying flat on the floor.
- Pry out light lens at slots.
- Remove old bulb from the socket by pulling from socket.
- Replace bulb by pressing into socket.
- Only use a bulb rated 13 V AC-9 Watts.
- Reinstall light lens by snapping into place.
- Return the cleaner to the upright position.

Cleaning Agitator

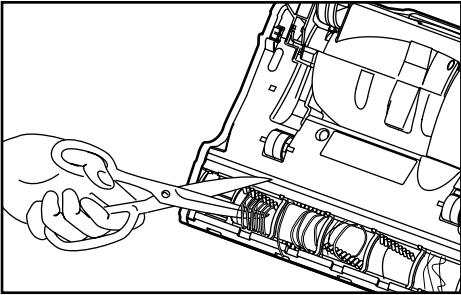

- Clean agitator after every five uses
- Selector should be placed in **BARE FLOOR (TOOLS)** position.
- Turn vacuum over.
- Cut off any carpet pile and lint entangled around agitator with a pair of scissors through the slots provided.

Removing and Installing Lower Plate



WARNING

Electrical Shock or Personal Injury Hazard.

Disconnect the electrical supply before servicing or cleaning the unit. Failure to do so could result in electrical shock or personal injury from cleaner suddenly starting.

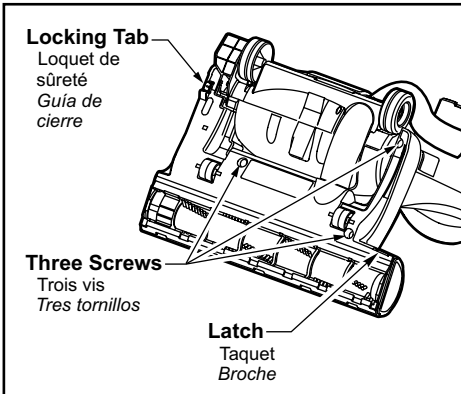

- Before servicing any parts, disconnect vacuum from electrical outlet.
- Place paper under nozzle whenever lower plate is removed to protect floor.
- Place handle in upright position and turn vacuum over to expose lower plate.
- Release lower plate by removing three (3) screws.
- Remove lower plate and remove any residue that may exist in belt area.
- Reinstall lower plate by hooking front end of lower plate into slot on front of nozzle housing.
- Be sure the latch on the lower plate is snapped in the slot on nozzle housing.
- Press lower plate into place and reinstall three (3) screws.

Replacing Belt

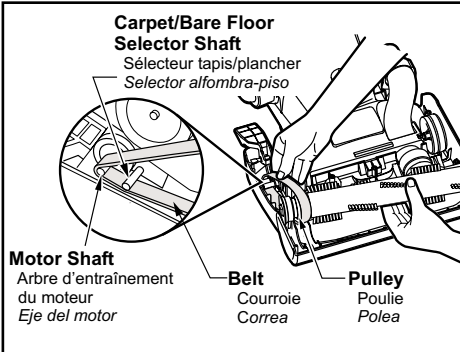

- Remove lower plate and agitator.
- Remove worn or broken belt.
- Loop new belt (Panasonic Type UB8 only) around motor shaft and pulley as shown.
- Reinstall agitator back into nozzle housing grooves.
- After reinstalling the agitator, turn it by hand to make sure that belt is not twisted or pinched and that all rotating parts turn freely.

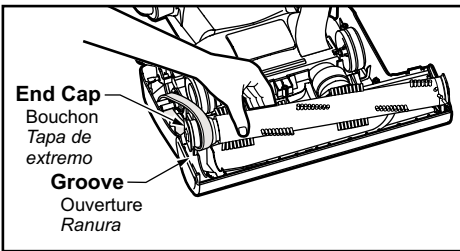

- Reinstall lower plate.

Replacing Agitator

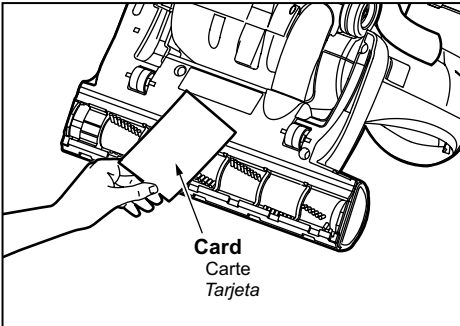

- When the bristles on the agitator are worn so that they do not touch a card held across the lower plate, the agitator should be replaced.
- Remove lower plate and agitator.
- Position belt over belt pulley on the new agitator.
- Reinstall agitator and lower plate.

Agitator Assembly

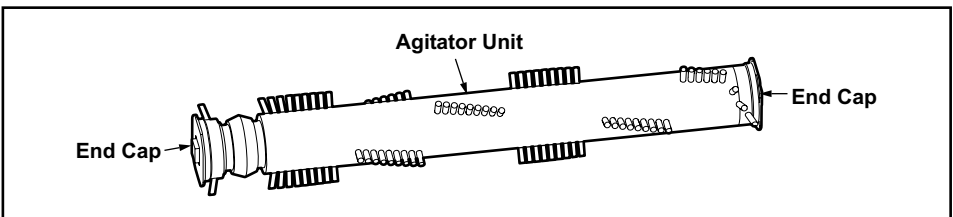

Cleaning Exterior

- Unplug cord from wall outlet.
- Clean exterior using a clean, soft cloth that has been dipped in a solution of mild liquid detergent and water and wrung dry.
- DO NOT drip water on cleaner and wipe dry after cleaning.
- DO NOT clean tools in dishwasher or clothes washer.
- Wash tools in warm soapy water, rinse and air dry.
- DO NOT use tools if they are wet.

Removing Clogs

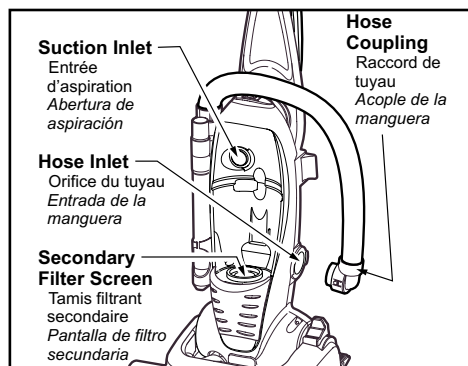

The hose located on the vacuum cleaner carries the dirt from the nozzle up to the dust bin. If the hose should become clogged:

- Unplug vacuum.
- Remove hose coupling and check hose coupling and hose inlet for clogs.
- Check suction inlet and secondary filter screen for clogs.
- Disconnect wand from connector pipe and short hose, check the wand and hose.
- Plug in vacuum cleaner and turn on.

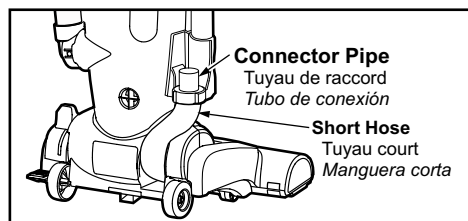

- Disconnect wand and stretch hose in and out to remove clog.

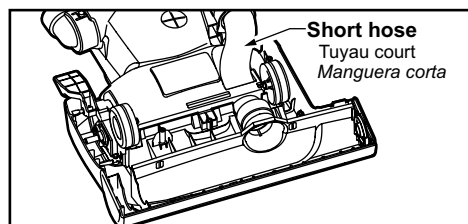

- If clog still exists, turn vacuum cleaner OFF and UNPLUG POWER CORD.
- Turn vacuum over and inspect agitator area for clogs.

BEFORE REQUESTING SERVICE



WARNING

Electric Shock or Personal Injury Hazard.

Disconnect the electrical supply before servicing or cleaning the unit. Failure to do so could result in electric shock or personal injury from cleaner suddenly starting.

Review this chart to find do-it-yourself solutions for minor performance problems. Any service needed, other than that described in these Operating Instructions, should be performed by an authorized service representative.

| PROBLEM | POSSIBLE CAUSE | POSSIBLE SOLUTION |
|---|---|--|
| Cleaner will not run. | <ol style="list-style-type: none"> 1. Unplugged at wall outlet. 2. ON-OFF switch not turned on. 3. Tripped circuit breaker/blown fuse at household service panel. | <ol style="list-style-type: none"> 1. Plug in firmly. Push ON-OFF switch to ON. 2. Push ON-OFF switch to ON. 3. Reset circuit breaker or replace fuse. |
| Poor job of dirt pickup. | <ol style="list-style-type: none"> 1. Full or clogged dust bin. 2. Broken belt. 3. Carpet-bare floor setting incorrect. 4. Clogged hose or nozzle. 5. Hose not inserted fully. 6. Worn agitator. 7. Hole in hose. 8. Dust bin assembly improperly installed. 9. Belt not installed on motor shaft. | <ol style="list-style-type: none"> 1. Empty dust bin. 2. Replace belt. 3. Set in the correct position. 4. Clean hose or nozzle area. 5. Insert hose. 6. Replace agitator. 7. Replace hose. 8. Properly install dust bin assembly. 9. Install belt on motor shaft. |
| Bare floor option will not work. | <ol style="list-style-type: none"> 1. Belt improperly installed with bare floor selector in wrong position. | <ol style="list-style-type: none"> 1. Properly install belt. |
| Dust escapes the dust bin. | <ol style="list-style-type: none"> 1. Dust bin assembly improperly installed. | <ol style="list-style-type: none"> 1. Properly install dust bin. |
| Light will not work. | <ol style="list-style-type: none"> 1. Burned out light bulb. | <ol style="list-style-type: none"> 1. Replace light bulb. |

WARRANTY

Panasonic Vacuum Cleaner Limited Warranty

Panasonic Consumer Electronics Company (collectively referred to as "the warrantor") will repair this product with new or refurbished parts free of charge, in the U.S.A. or Puerto Rico for one (1) year from the date of original purchase in the event of a defect in materials or workmanship.

This Limited Warranty Excludes both Labor and Parts for the following items which require normal replacement: Disposable Dust Bag, Filters, Belts, Light Bulbs, Agitator Brushes and Batteries (if supplied).

Carry-in or mail-in service in the U.S.A. can be obtained during the warranty period by contacting a Panasonic Services Company (PASC) Factory Servicenter listed in the Servicenter Directory. Or call, toll free, 1-800-211-PANA (7262) to locate a PASC Authorized Servicenter. Carry-in or mail-in service in Puerto Rico can be obtained during the warranty period by calling the local Panasonic Sales Company telephone number listed in the Servicenter Directory.

This warranty is extended only to the original purchaser. A purchase receipt or other proof of date of original purchase will be required before warranty performance is rendered.

This warranty only covers failures due to defects in materials and workmanship which occur during normal use and does not cover damages which occur in shipment, or failures which are caused by products not supplied by the warrantor, or failures which result from accident, misuse, abuse, neglect, mishandling, misapplication, faulty installation, improper operation or maintenance, alteration, modification, power line surge, improper voltage supply, lightning damage, commercial use such as hotel, office, restaurant or other business or rental use of the product, or service by anyone other than a PASC Authorized Servicenter, or damage that is attributable to acts of God.

LIMITS AND EXCLUSIONS:

There are no express warranties except as listed above.

THE WARRANTOR SHALL NOT BE LIABLE FOR INCIDENTAL OR CONSEQUENTIAL DAMAGES RESULTING FROM THE USE OF THIS PRODUCT, OR ARISING OUT OF ANY BREACH OF THIS WARRANTY. ALL EXPRESS AND IMPLIED WARRANTIES, INCLUDING THE WARRANTIES OF MERCHANTABILITY AND FITNESS FOR A PARTICULAR PURPOSE, ARE LIMITED TO THE APPLICABLE WARRANTY PERIOD SET FORTH ABOVE.

Some states do not allow the exclusion or limitation of incidental or consequential damages, or limitations on how long an implied warranty lasts, so the above exclusions or limitations may not apply to you.

This warranty gives you specific legal rights and you may also have other rights which vary from state to state. If a problem with this product develops during or after the warranty period, you may contact your dealer or Servicenter. If the problem is not handled to your satisfaction, then write to the Consumer Affairs Department at the listed address on the back cover.

WARRANTY

Panasonic Canada Inc.
5770 Ambler Drive, Mississauga, Ontario L4W 2T3

PANASONIC PRODUCT - LIMITED WARRANTY

Panasonic Canada Inc. warrants this product to be free from defects in material and workmanship and agrees to remedy any such defect for a period as stated below from the date of original purchase.

Vacuum Cleaner - One (1) year, parts and labour

LIMITATIONS AND EXCLUSIONS

This warranty does not apply to products purchased outside Canada or to any product which has been improperly installed, subjected to usage for which the product was not designed, misused or abused, damaged during shipping, or which has been altered or repaired in any way that affects the reliability or detracts from the performance, nor does it cover any product which is used commercially. Parts such as disposable dust bags, filters, belts, light bulbs and agitator brushes are also excluded from coverage under this warranty.

This warranty is extended to the original end user purchaser only. A purchase receipt or other proof of date of original purchase is required before warranty service is performed.

THIS EXPRESS, LIMITED WARRANTY IS IN LIEU OF ALL OTHER WARRANTIES, EXPRESS OR IMPLIED, INCLUDING ANY IMPLIED WARRANTIES OF MERCHANTABILITY AND FITNESS FOR A PARTICULAR PURPOSE. IN NO EVENT WILL PANASONIC CANADA INC. BE LIABLE FOR ANY SPECIAL, INDIRECT OR CONSEQUENTIAL DAMAGES.

In certain instances, some jurisdictions do not allow the exclusion or limitation of incidental or consequential damages, or the exclusion of implied warranties, so the above limitations and exclusions may not be applicable.

WARRANTY SERVICE

For product operation and information assistance, please contact your Dealer or our Customer Care Centre at:
Telephone #: (905) 624-5505 Fax #: (905) 238-2360 Web: www.panasonic.ca

For product repairs, please contact one of the following:

- Your Dealer who will inform you of an authorized Servicentre nearest you.
- Our Customer Care Centre at (905) 624-5505 or www.panasonic.ca
- A Panasonic Factory Servicentre listed below:

Richmond, British Columbia

Panasonic Canada Inc.
12111 Riverside Way
Richmond, BC V6W 1K8
Tel: (604) 278-4211
Fax: (604) 278-5627

Calgary, Alberta

Panasonic Canada Inc.
6835-8th St. N.E.
Calgary, AB T2E 7H7
Tel: (403) 295-3955
Fax: (403) 274-5493

Mississauga, Ontario

Panasonic Canada Inc.
5770 Ambler Dr.
Mississauga, ON L4W 2T3
Tel: (905) 624-8447
Fax: (905) 238-2418

Lachine, Québec

Panasonic Canada Inc.
3075, rue Louis A. Amos
Lachine, QC H8T 1C4
Tel: (514) 633-8684
Fax: (514) 633-8020

IF YOU SHIP THE PRODUCT TO A SERVICENTRE

Carefully pack and send prepaid, adequately insured and preferably in the original carton.
Include details of the defect claimed, and proof of date of original purchase.