

Panasonic®

VACUUM CLEANER
Aspiradora

MC-V7400D

Operating Instructions

Instrucciones de operación

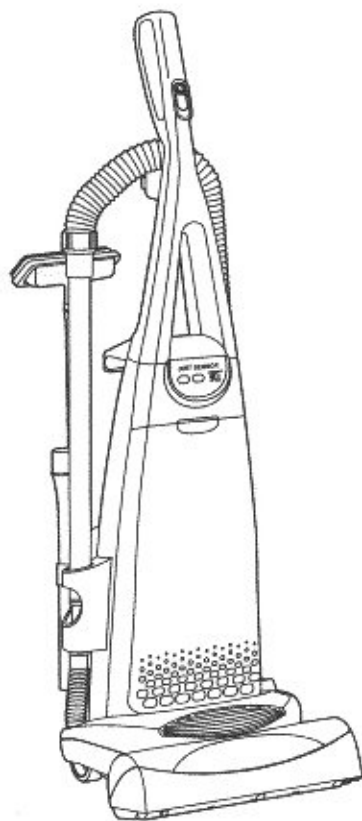

Before operating your vacuum cleaner, please read these instructions completely.

Antes de usar su aspiradora, lea completamente estas instrucciones por favor.

C01ZBBS00U00

CONSUMER INFORMATION

Please read **IMPORTANT SAFETY INSTRUCTIONS** on page 5 before use. Read and understand all instructions.

TO OUR VALUED CUSTOMER

We are very pleased to welcome you to the Panasonic family of products. Thank you for purchasing this product. Our intent is that you become one of our many satisfied customers.

Proper assembly and safe use of your vacuum cleaner are your responsibilities. Your vacuum cleaner is intended only for household use. The cleaner should be stored in a dry, indoor area. Read the Operating Instructions carefully for important use and safety information.

Special care is required when vacuuming certain types of carpet or floor covering. Always check the carpet or floor covering manufacturer's recommended cleaning instructions before vacuuming.

PLEASE PAY CLOSE ATTENTION TO ALL WARNING AND CAUTION STATEMENTS.



WARNING

WARNING statements are designed to alert you to the possibility of personal injury, loss of human life, and/or damage to the vacuum cleaner and/or personal property if the instructions given are not followed.



CAUTION

CAUTION statements are designed to alert you to the possibility of damage to the vacuum cleaner and/or personal property if the instructions given are not followed.



WARNING

TO AVOID ELECTRICAL SHOCK

Never vacuum damp or wet surfaces or liquids.
DO NOT store machine outdoors.
Replace worn or frayed power cord immediately.
Unplug from outlet when not in use and before servicing.

TO AVOID ACCIDENTS

Except for hand-held cleaners, keep machine on floor - not chairs, tables, steps, stairs, etc.
Store machine promptly after each use to prevent accidents such as tripping over power cord or machine.
Use machine and accessories only in a manner intended by the manufacturer.
The use of an extension cord is not recommended.

TABLE OF CONTENTS / *Tabla de contenido*

| | |
|--|-------|
| CONSUMER INFORMATION / Información para consumidor | 2-3 |
| IMPORTANT SAFETY INSTRUCTIONS <i>Instrucciones importantes de seguridad</i> | 5-6 |
| PARTS IDENTIFICATION / Identificación de piezas | 7 |
| ASSEMBLY / Montaje | 8 |
| Attaching Handle / Colocación del mango | 8 |
| Using Cord Reel / Usando el mecanismo de enrollar | 8 |
| Tool Storage / Almacenaje de herramientas | 9 |
| FEATURES / Características | 10 |
| Automatic Self Adjusting Nozzle / Boquilla de ajuste automático | 10 |
| Edge Cleaning / Limpieza para orillas | 10 |
| Motor Protector / Protector del motor | 10 |
| Thermal Protector / Protector termal | 11 |
| Agitator Overload Protector / Protector de sobrecarga del agitador | 11 |
| Agitator On-Off Selector / Agitador Encendido-Apagado selector | 11 |
| Agitator Thermal Protector / Protector Térmico del Agitador | 12 |
| Hose Ring and Hose Ring Mount <i>Anillo de manguera y soporte del anillo para manguera</i> | 12 |
| Dirt Sensor / Sensor de polvo | 12 |
| TO OPERATE CLEANER / Para operar la aspiradora | 13 |
| Power Cord / Cordón eléctrico | 13 |
| ON-OFF Switch / Control ON-OFF | 13 |
| Handle Adjustments / Ajustes del mango | 13 |
| Using Tools / Uso de herramientas | 14 |
| ROUTINE CARE OF CLEANER / Cuidado de rutina de la aspiradora | 15 |
| Cleaning Secondary Foam Filter <i>Limpieza del segundo filtro de goma espuma</i> | 15 |
| Replacing HEPA Exhaust Filter / Cambiar del filtro de escape HEPA | 15 |
| Changing Dust Bag / Cambio de la bolsa de polvo | 16 |
| Replacing Headlight Bulb / Cambio de la bombilla | 17 |
| Cleaning Agitator / Limpieza del agitador | 17 |
| Cleaning Dirt Sensor Optics <i>Limpieza de los ópticos del sensor de polvo</i> | 18 |
| Cleaning Exterior and Tools / Limpieza del exterior y de los herramientas | 18 |
| Removing Clogs / Quitar de los residuos de basura en los conductos | 19 |
| BEFORE REQUESTING SERVICE / Antes de pedir servicio | 20-21 |
| WARRANTY / Garantía | 22-23 |
| WHAT TO DO WHEN SERVICE IS NEEDED / Cuando necesita servicio | 24 |

IMPORTANT SAFETY INSTRUCTIONS

When using vacuum cleaner, basic precautions should always be followed, including the following:

READ ALL INSTRUCTIONS BEFORE USING THIS VACUUM CLEANER



WARNING

To reduce the risk of fire, electrical shock, injury:

1. **DO NOT** leave vacuum cleaner when plugged in. Unplug from outlet when not in use and before servicing.
2. To reduce the risk of fire, electric shock - **DO NOT** use outdoors or on wet surfaces.
3. **DO NOT** allow to be used as a toy. Close attention is necessary when used by or near children.
4. Use only as described in this manual. Use only manufacturer's recommended tools.
5. **DO NOT** use with damaged cord or plug. If vacuum cleaner is not working as it should, has been dropped, damaged, left outdoors, or dropped into water, return it to an authorized Panasonic Servicerter.
6. **DO NOT** pull or carry by cord, use cord as a handle, close door on cord, or pull cord around sharp edges or corners. **DO NOT** run vacuum cleaner over cord. Keep cord away from heated surfaces.
7. **DO NOT** unplug by pulling on cord. To unplug, grasp the plug, not the cord.
8. **DO NOT** handle plug or vacuum cleaner with wet hands.
9. **DO NOT** put any objects into openings. **DO NOT** use with any opening blocked; keep free of dust, lint, hair, and anything that may reduce air flow.
10. Keep hair, loose clothing, fingers, and all parts of body away from openings and moving parts.
11. **DO NOT** pick up anything that is burning or smoking, such as cigarettes, matches, or hot ashes.
12. **DO NOT** use without dust bag and/or filters in place.
13. Turn off all controls before unplugging.
14. Use extra care when cleaning on stairs.
15. **DO NOT** use cleaner to pick up flammable or combustible liquids such as gasoline or use in areas where they may be present.
16. **HOLD** plug when rewinding onto cord reel. Do not allow plug to whip when rewinding.

SAVE THESE INSTRUCTIONS

THIS VACUUM CLEANER IS INTENDED FOR HOUSEHOLD USE ONLY

Note: Before you plug in your Panasonic vacuum cleaner, make sure that the voltage indicated on the rating plate located at the back of the vacuum cleaner is the same as your local supply.

PARTS IDENTIFICATION

Identificación de piezas

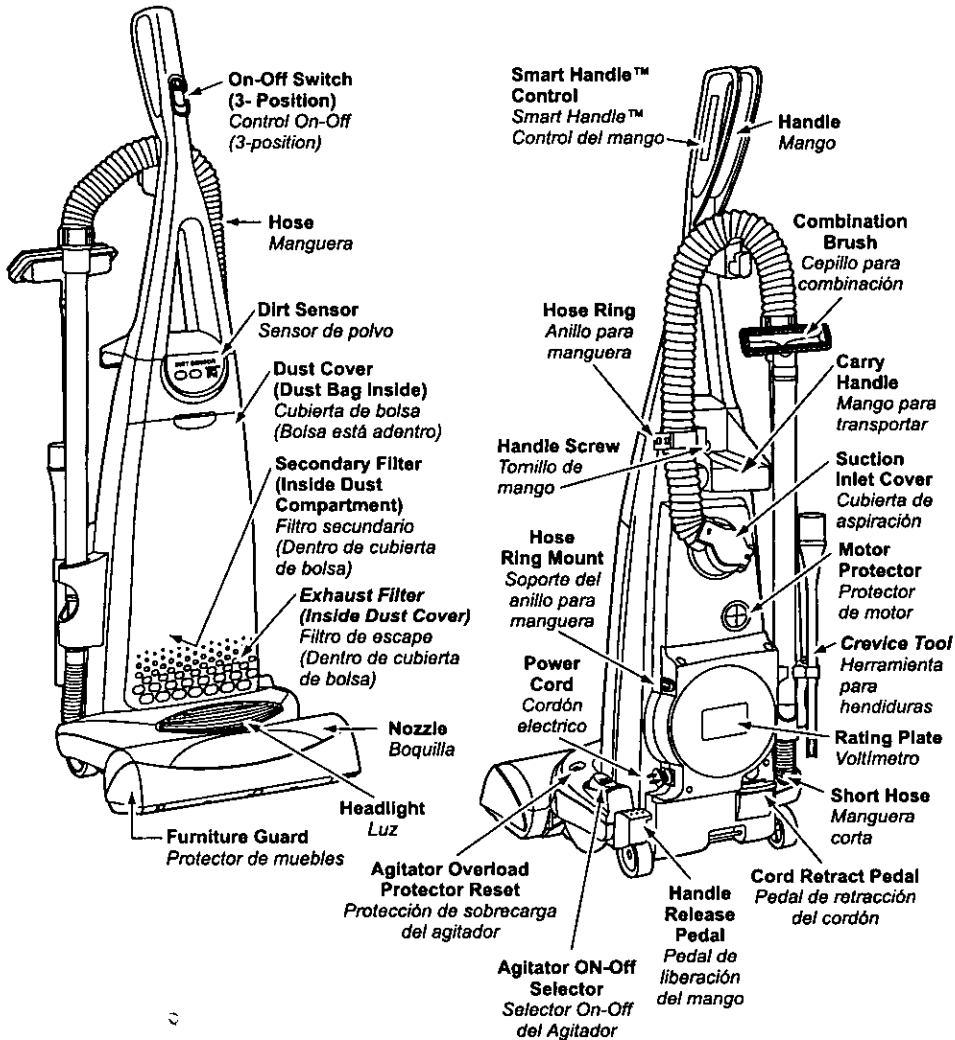

FEATURE CHART / Diagrama de características (PANASONIC UPRIGHT VACUUM) (Aspiradora vertical Panasonic)

| FEATURES Características | Power Voltaje | Cord Reel Mecanismo de enrollar el cordón | Headlight Luz | Cord Length Extensión de cordón | Bare Floor Uso sin alfombra |
|-----------------------------|-----------------------------------|---|------------------|---------------------------------------|-----------------------------------|
| Model / Modelo MC-V7400D | 120V AC (60Hz) 12.0 A / 12,0 A | Yes Si | Yes Si | 28 FL (8.5 m) 8,5 m (28 pi) | Yes Si |

ASSEMBLY / Montaje

Attaching Handle / Colocación del mango

1)

➤ **DO NOT** plug in until assembly is complete
No enchufe hasta que el montaje esté completo

➤ Turn ON-OFF switch OFF
Mueva el control ON-OFF a la posición OFF

➤ Remove handle screw
Quite el tornillo del mango

➤ Insert handle
Instale el mango

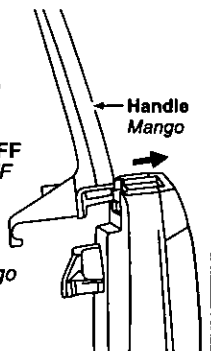

2)

➤ Insert screw
Instale el tornillo

➤ Tighten screw
Apreté el tornillo

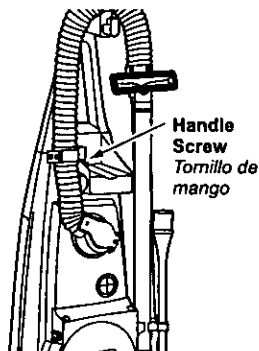

Using Cord Reel / Usando el mecanismo de enrollar

1)

➤ Pull cord out of cord reel until the end is reached
Tire del cordón del mecanismo de enrollar hasta que se alcance el extremo

➤ Do not use vacuum without cord pulled out all the way
No use la aspiradora sin que el cordón se extienda por completo

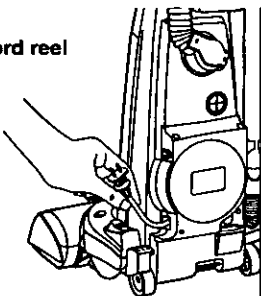

2)

➤ Push power cord into two (2) cord clips in back of handle
Empuje el cordón eléctrico hasta las dos (2) áreas indicadas en la parte trasera del mango

Power Cord
Cordón eléctrico

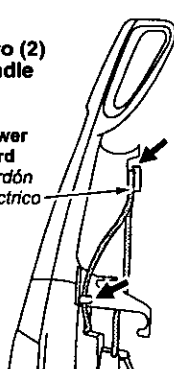

3)

➤ Plug the polarized power cord into a 120V outlet located near floor
Conecte el cordón eléctrico polarizado en un enchufe de 120 V que se encuentre cerca del piso

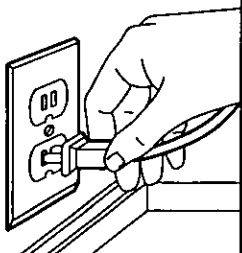

4)

➤ To prevent injury or damage, hold plug head while rewinding cord
Tenga en la mano el enchufe del cordón para evitar lesión personal o daño mientras se rebobina el cordón

➤ Push cord retract pedal down to rewind
Empuje hacia abajo el pedal de retracción del cordón para rebobinar

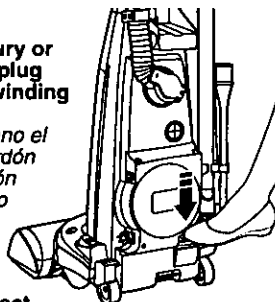

Tool Storage / Almacenaje de herramientas

Tools / Herramientas

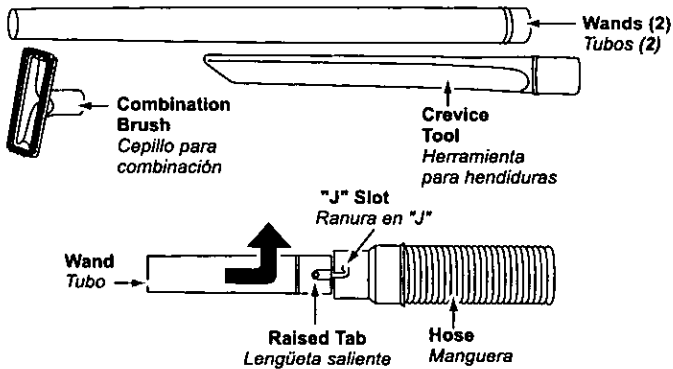

- Some tools may already be stored on vacuum cleaner
Es posible que ya se almacenen unas herramientas en la aspiradora

- Place hose in back of handle on hose holder
Coloque la manguera en la parte trasera del soporte de manguera

- Attach wand to hose by aligning the two (2) raised tabs on wand with "J" slots in hose, guide tabs along grooves, twist to lock in place

Para conectar el tubo a la manguera, alinee las dos (2) lengüetas levantadas en el tubo con las ranuras "J" en la manguera. Mueva las lengüetas hacia las ranuras, ruédelas para asegurar

- Place wand in front slot of tool holder, twisting and pushing down over short hose to assure a good connection

Coloque el tubo en la ranura delantera del soporte para herramientas, rodando y empujando hacia abajo a la manguera corta para asegurar una conexión buena

- Store other wand, with combination brush on top, in round rear slot of tool holder

Almacene el otro tubo con el cepillo de combinación en la parte superior en la ranura redonda y posterior del soporte para herramientas

- Place crevice tool into rectangular rear slot of tool holder

Coloque la herramienta para tapices en la ranura posterior y rectangular del soporte de herramientas

- Refer to PARTS IDENTIFICATION section for tool location

Véase la sección de "Identificación de piezas" para la ubicación de las herramientas

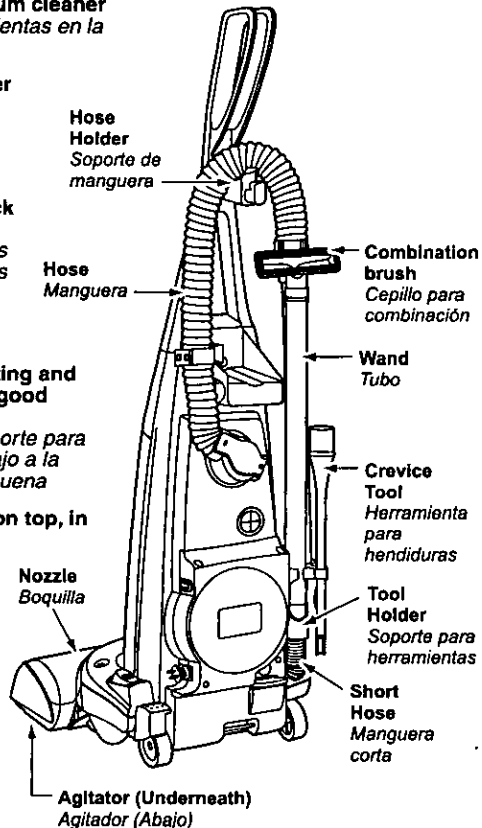

FEATURES / Características

Automatic Self Adjusting Nozzle

Boquilla de ajuste automático

- **The nozzle of your Panasonic upright vacuum cleaner automatically adjusts to any carpet pile height**
La boquilla de su aspiradora vertical Panasonic se ajusta automáticamente a la altura de cualquier pelo de alfombra
- **Feature allows nozzle to float evenly over carpet pile surfaces**
La característica permite que la boquilla flote fácilmente en las superficies del pelo de alfombra
- **No manual adjustments required**
No se requieren los ajustes manuales

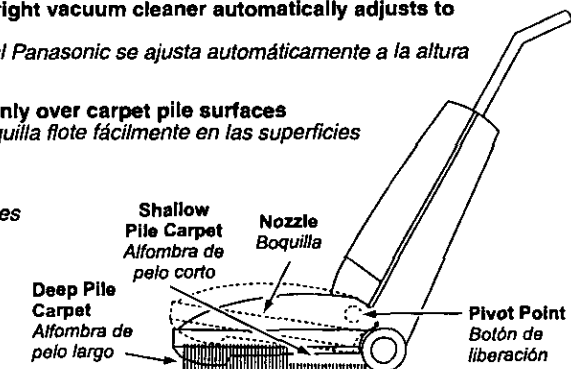

Edge Cleaning / Limpieza para orillas

- **Edge cleaning feature provides for improved cleaning of carpets near walls and furniture**
Use la característica de limpieza para orillas para aspirar con facilidad cerca de las paredes y los muebles

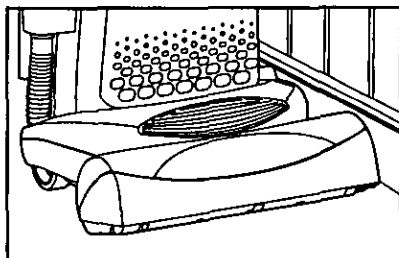

Motor Protector / Protector del motor

- **Motor protector automatically opens to provide cooling air when a clog occurs or when bag needs changing**
Se abre automáticamente el protector del motor para proveer el aire fresco cuando hay unos residuos o cuando se necesita cambiar la bolsa
- **Motor protector may open when using tools**
Es posible que el protector del motor se abra cuando se usan las herramientas
- **Check operation by placing hand over end of hose**
Revise la operación al colocar la mano en el extremo de la manguera

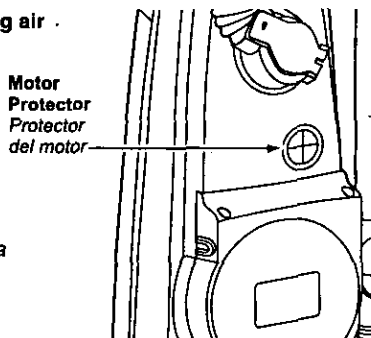

Thermal Protector / Protector termal

- **If a clog occurs, the thermal protector turns off the suction motor automatically**
Si ocurre una atascadura, el protector térmico apaga el motor de succión automáticamente.
- **Headlight will remain on**
La luz delantera se mantiene prendida
- **To correct problem, turn off and unplug vacuum, remove clogs, and clean/replace filters**
Para corregir, apague y desenchufe la aspiradora, saque las obstrucciones, y limpie/cambiar los filtros
- **Wait approximately thirty (30) minutes and plug vacuum in and turn back on**
Espere aproximadamente treinta (30) minutos y enchufe la aspiradora y voltéela

Agitator Overload Protector Protector de sobrecarga del agitador

- **The agitator motor has built-in protection from motor damage should the agitator jam**
El agitador tiene una protección incorporada contra daño del motor en caso de que el agitador se tranque
- **If agitator slows down or stops, the agitator overload protector will shut off the agitator motor**
Si el agitador se mueve más despacio o se para, el protector de sobrecarga del agitador apagará el motor del agitador.
- **The suction motor continues to run**
El motor de succión continuará funcionando
- **To correct problem, turn off and unplug vacuum, remove obstruction**
Para corregir, apague y desenchufe la aspiradora, saque la obstrucción
- **Press agitator overload protector reset button to reset agitator**
Para reajustar, empuje el botón de protección de sobrecarga del agitador

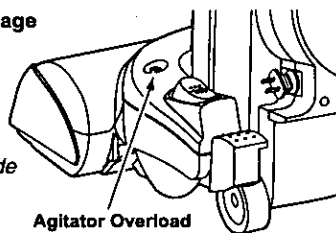

Agitator Overload
Protector Reset
Protección de sobrecarga
del agitador

Agitator On-Off Selector Selector On-Off del Agitador

- **Selector should be placed in Off position when using cleaner on bare floors and when using tools**
Se debe colocado el selector en la posición Apagado (OFF) cuando pasa la aspirador en los suelos sin alfombra y cuando se usan las herramientas
- **The agitator does not rotate in the Off position**
El agitador no rueda en la posición Apagado (OFF)
- **Selector should be placed in On position when using cleaner on carpeted floors**
Se debe colocado el selector en la posición Encendido (ON) cuando pasa la aspiradora en los suelos con alfombra
- **Light will remain on when vacuuming with the selector in the Off position - provided the vacuum is not in the full upright position**
La luz se mantendrá encendida mientras se aspira con el agitador en posición Apagado (OFF), siempre y cuando la aspiradora no se encuentre completamente en posición vertical

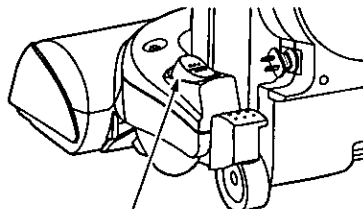

Agitator ON-Off
Selector
Selector On-Off
del Agitador

- ***The agitator will not rotate if the vacuum is in the full upright position**
**El agitador no rueda si la aspiradora encuentre completamente en posición vertical*

Agitator Thermal Protector

Protector Térmico del Agitador

- > **Agitator thermal protector trips to prevent agitator motor from overheating**
El protector térmico del agitador salta para prevenir que se recaliente el motor del agitador
- > **Agitator thermal protector may trip if vacuum is operated with agitator rotating and hose removed from tool holder**
El protector térmico del agitador puede saltar si el vacío es operado con el agitador rotando y la manguera separada del soporte de herramienta
- > **To correct problem, turn off and unplug vacuum**
Para corregir, apague y desenchufe la aspiradora
- > **Wait approximately thirty (30) minutes and plug vacuum in and turn back on**
Espere aproximadamente treinta (30) minutos y enchufe la aspiradora y voltéela

Hose Ring and Hose Ring Mount

Anillo de manguera y soporte del anillo para manguera

- > **Hose ring and hose ring mount are designed to prevent tipping of vacuum while using tools**
El anillo de manguera y el soporte del anillo para manguera están diseñados para impedir que la aspiradora no volque cuando se utilizan las herramientas
- > **Place hose ring in hose ring mount as shown in illustration**
Coloque el anillo para manguera en el soporte del anillo para manguera como se ve en el diagrama

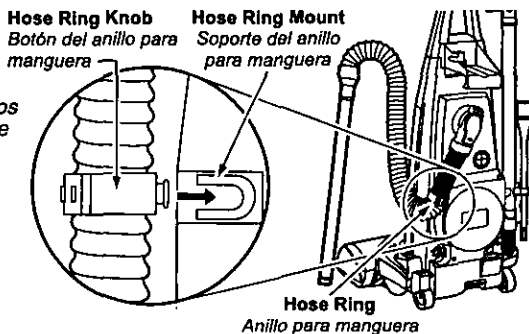

Dirt Sensor / Sensor de polvo

- > **The DIRT SENSOR detects dirt passing through the vacuum**
El sensor de polvo detecta el polvo pasando por la aspiradora
- > **A Red light indicates that dirt is being picked up by the vacuum**
Una luz roja indica que la aspiradora aspira el polvo
- > **A Green light indicates cleaning is complete**
Una luz verde indica que la limpieza está completa
- > **Set the sensor sensitivity switch to HI when cleaning bare floors or carpet with low pile height**
Coloque el control de sensibilidad del sensor en la posición HI para limpiar los suelos sin alfombra o las alfombras del pelo bajo
- > **Set the sensor switch to LO when cleaning heavily soiled areas, carpet with deep pile or new carpet**
Coloque el control de sensibilidad del sensor en la posición LO para limpiar las áreas bien sucias, las alfombras del pelo alto o las alfombras nuevas
- > **Fuzz from new carpets may cause the red light to remain on longer than expected**
La pelusa de las alfombras nuevas puede causar que la luz roja se enciende por más tiempo que es normal

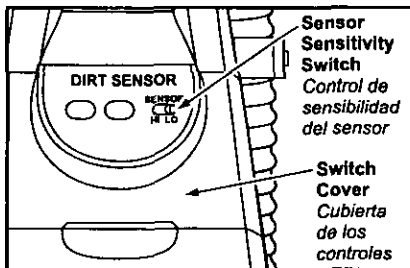

TO OPERATE CLEANER

Para operar la aspiradora

Power Cord / Cordón eléctrico

NOTE: To reduce the risk of electrical shock, this vacuum has a polarized plug, one blade is wider than the other. This plug will fit in a polarized outlet only one way. If the plug does not fit fully in the outlet, reverse the plug. If it still does not fit, contact a qualified electrician to install the proper outlet. **DO NOT CHANGE THE PLUG IN ANY WAY.** Only use outlets near the floor.

Nota: Para reducir el riesgo de choque eléctrico, esta aspiradora cuenta con una clavija polarizada, uno de los contactos es más ancho que el otro. La clavija sólo puede insertarse de una manera en el enchufe. Si la clavija no cabe bien en el enchufe, inviértala. Si aún no cabe, llame a un electricista para que instale un enchufe correcto. No altere la clavija de ninguna manera. No altere la clavija de ninguna manera. Use solamente las tomas de pared cercas del suelo.

ON-OFF Switch / Control ON-OFF

- **Ensure ON-OFF switch is OFF**
Asegúrese de que el control ON-OFF esté en la posición OFF
- **Plug the power cord into 120V outlet**
Enchufe el cordón eléctrico en una toma de pared de 120 V
- **In LOCK ON position the vacuum runs continuously**
La aspiradora funciona continuamente cuando el control está en la posición LOCK ON
- **ON position allows vacuum to be operated by gripping the handle, USE CARE**
La posición ON permite que se opere la aspiradora mientras que agarra el mango
- **OFF position turns vacuum off**
La posición OFF apaga la aspiradora

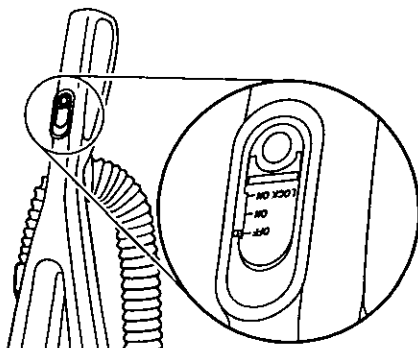

Handle Adjustments / Ajustes del mango

- **Step on handle release pedal to change handle position**
Pise en el pedal de liberación del mango para cambiar la posición del mango
- **Move vacuum to upright position for storage and tool use**
Mueva la aspiradora a la posición vertical para el almacenaje y el uso de las herramientas
- **Move vacuum to middle position for normal use**
Mueva la aspiradora a la posición mediana para el uso normal
- **Use low position for cleaning under furniture**
La posición baja para limpiar debajo de los muebles

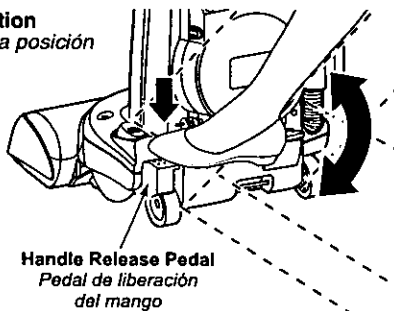

*The agitator will not rotate if the vacuum is in the full upright position
*El agitador no rueda si la aspiradora encuentra completamente en posición vertical

Using Tools / Uso de herramientas

- **ALWAYS** place agitator On-Off selector in Off position when using tools
Al usar las herramientas siempre coloque el agitador encendido-apagado selector en la posición apagado (OFF)
- **Remove wand from short hose by twisting and pulling up**
Rodando y levantando hacia arriba quite el tubo de la manguera corta
- **The tools can be attached to hose, wand(s) or crevice tool**
Se puede conectar las herramientas con la manguera, el tubo(s) o la herramienta de hendiduras
- **DO NOT** overextend your reach with hose as it could tip vacuum
No extienda demasiado la extensión de la manguera porque puede causar que la aspiradora vuelque
- **To prevent tipping of vacuum, use hose ring and mount when cleaning areas below upper cord hook with the tools**
Use el anillo de manguera y el soporte al limpiar con las herramientas las áreas bajo del nivel del gancho superior para que la aspiradora no vuelque
- **The combination brush can be used with or without brush**
Se puede usar el cepillo de combinación con o sin el cepillo

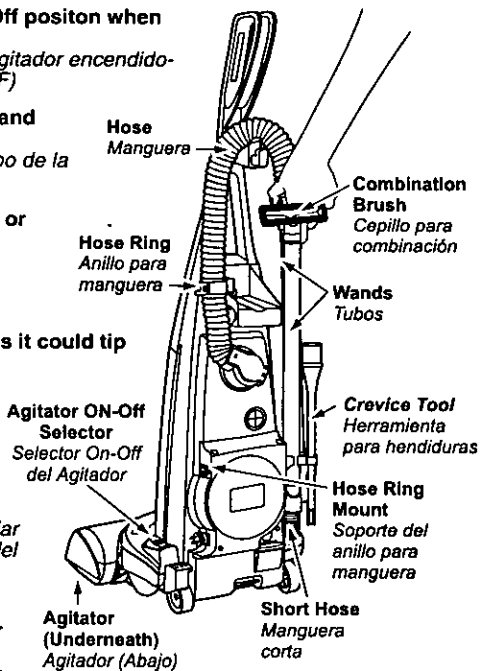

TOOL USE / Uso de herramientas

| TOOL / Herramienta | CLEANING AREA / Área para limpiar | | | | |
|--|-----------------------------------|---------------------|--------------------|---------------------|------------------|
| | Furniture Muebles | Cushions Cojines | Drapes Cortinas | Stairs Escaleras | Walls Paredes |
| CREVICE TOOL <i>Herramienta para hendiduras</i> | X | X | X | X | X |
| COMBINATION BRUSH <i>Cepillo para combinación</i> | X | | X | X | |

Always clean tools before using
Siempre limpie las herramientas antes de usarlas

ROUTINE CARE OF CLEANER

Cuidado de rutina de la aspiradora

Performing the following tasks will keep your new Panasonic vacuum cleaner operating at peak performance levels and will ensure these high levels for years to come. Check the **BEFORE REQUESTING SERVICE** section in this manual for recommendations on performing some of these tasks to help solve various problems that may occur.

Siguiendo las instrucciones dadas, se nueva aspiradora Panasonic funcionará al nivel máximo y continuará funcionando por muchos años en el futuro. Lea la sección "Antes de pedir servicio" en este manual para las recomendaciones para arreglar unos problemas que puedan ocurrir.

Cleaning Secondary Foam Filter

Limpeza del segundo filtro de goma espuma

- **The secondary foam filter protects the motor**
El segundo filtro de goma espuma protege el motor
- **Check filter when installing a new dust bag**
Al instalar una nueva bolsa de polvo revise el filtro
- **If dirty, pull filter from bottom of dust compartment and clean by rinsing in water**
Si está sucio, tire del filtro del fondo del compartimento de polvo y límpielo enjuagando con agua
- **When dry, slide filter back into place**
Cuando esté seco deslice el filtro a su lugar
- **Ensure filter is fully inserted under plastic rib projections**
Asegúrese de que el filtro está instalado debajo de las lengüetas plásticas

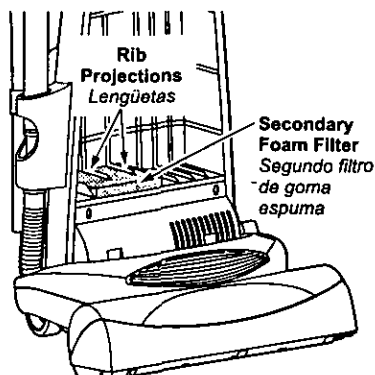

Replacing HEPA Exhaust Filter

Cambiar del filtro de escape HEPA

- **The HEPA exhaust filter removes dirt from recirculated air**
El filtro de escape HEPA quita el polvo del aire reciclado
- **Check filter when installing a new dust bag**
Revise el filtro al instalar una nueva bolsa de polvo
- **If dirty, remove filter from bottom of the dust cover by pulling straight up on retainers on frame. Lift one side at a time**
Si está sucio, quite el filtro del fondo de la cubierta de polvo al tirar hacia arriba en las lengüetas del marco. Levante un lado y después el otro lado
- **Place new filter in dust cover DO NOT CLEAN WITH WATER***
*Coloque el filtro nuevo en la cubierta de polvo No limpie con agua**
- **Place filter in frame and install in dust cover, making sure white side is facing up**
Coloque el filtro en el marco y instale la cubierta de polvo asegurando de que el lado blanco dé hacia arriba

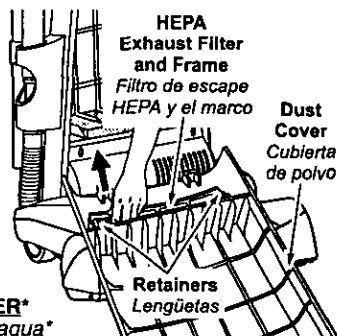

*Filter cannot be cleaned and should be replaced at least once each year
**No se puede limpiar el filtro y se debe cambiarlo a lo menos una vez cada año*

Changing Dust Bag

Cambio de la bolsa para polvo

Always operate vacuum with genuine Panasonic Type U3 Standard or U6 Electrostatic dust bags installed. Panasonic dust bags may be purchased through any authorized Panasonic dealer or ordered from service company.

Siempre opere la aspiradora con las bolsas Panasonic Type U3 Standard U6 Electrostatic instaladas. Se puede comprar las bolsas de polvo en cualquier vendedor autorizado Panasonic o mandar de una compañía de servicio

- 1)
➤ Pull outward on dust cover grip to remove the dust cover
Empuje hacia afuera en la cubierta de polvo para quitarla

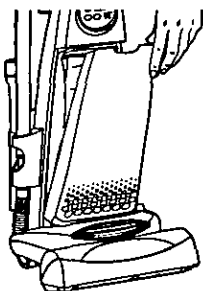

- 2)
➤ Remove dust bag by grasping cardboard portion and pulling out
Agarre la parte de cartón de la bolsa y empuje hacia afuera para quitar la bolsa de polvo

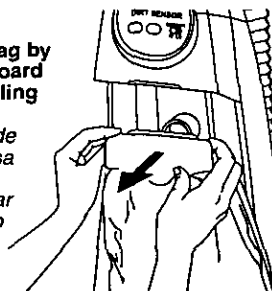

- 3)
➤ Spread out new dust bag, taking care not to tear bag
Extienda la nueva bolsa de polvo teniendo cuidado de no romper la bolsa

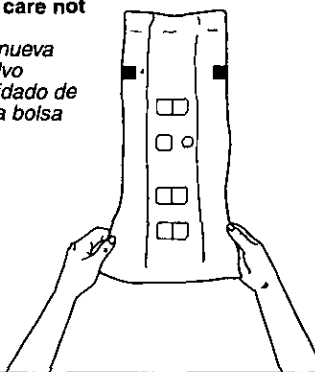

- 4)
➤ Fold new dust bag to clear slots as shown
Doble la nueva bolsa de polvo para que no toque las ranuras como se ve en el diagrama

- Attach new dust bag onto bag holder by holding cardboard portion and pushing back
Teniendo la parte de cartón y empujando hacia atrás instale la nueva bolsa de polvo en el soporte para la bolsa

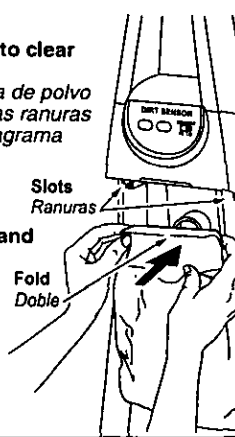

- 5)
➤ Reinsert tabs on end of dust cover into grooves on dust compartment to allow cover to rotate closed
Reinstale las lengüetas en el extremo de la cubierta de polvo en las ranuras en el compartimento de polvo para que la cubierta ruede hasta la posición cerrada

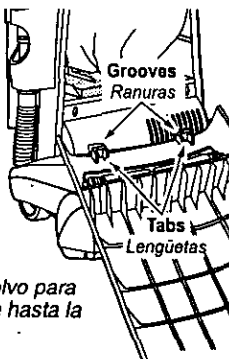

- 6)
➤ Rotate dust cover up into closed position and press into place without pinching dust bag
Ruede la cubierta de polvo hasta la posición cerrada y apriétela en su lugar sin apretar la bolsa de polvo

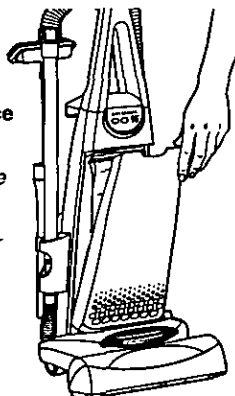

Replacing Headlight Bulb / Cambio de la bombilla

- **Pry up light lens at slots**
Levante lentes de luz en las ranuras
- **Remove old bulb from the socket by pushing in while turning counterclockwise**
Quite la bombilla vieja del casquillo portalámparas al empujar hacia adentro y rodar en el sentido contrario de las agujas de reloj al mismo tiempo
- **Replace bulb by pushing in while turning clockwise**
Reemplace la bombilla empujando hacia adentro y rodando en el sentido de las agujas de reloj al mismo tiempo
- **Only use a bulb rated 130 V AC-15 Watts or less**
Use solamente una bombilla de 130 V AC-15 vatios o de menos voltios
- **Replace light lens by snapping into place**
Reemplace lentes de luz empujándolos en su lugar

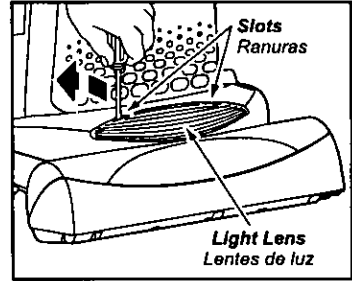

Cleaning Agitator / Limpieza del agitador

- **Clean agitator after every five uses**
Limpie el agitador después de cada cinco utilizaciones
- **Turn vacuum over, exposing the agitator**
Dé vuelta la aspiradora, exponiendo el agitador
- **Cut off any carpet pile and lint entangled around agitator with a pair of scissors**
Corte con unas tijeras el pelo de alfombra y la pelusa envueltos en el agitador

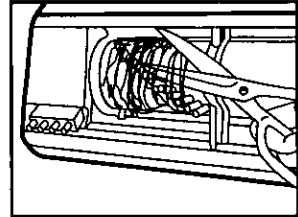

Cleaning Dirt Sensor Optics

Limpieza de los ópticos del sensor de polvo

- **The DIRT SENSOR optics consist of two optic cells located inside the bag holder**

Los ópticos del sensor de polvo consisten en dos células ópticas situadas en el soporte para la bolsa

- **The optic cells should be cleaned when the red light does not light and when the dust bag is changed**

Se debe limpiar las células ópticas cuando la luz roja no se enciende y cuando se cambia la bolsa.

- **To clean, remove the dust cover and dust bag**

Quite la cubierta de polvo y la bolsa de polvo para limpiar

- **Wipe the optic cells with a soft, dry cloth**

Limpie las células ópticas con un trapo suave y seco

- **DO NOT use cleaners or liquids**

No use los limpiadores ni los líquidos

- **Replace the dust cover and dust bag**

Reemplace la cubierta de polvo y la bolsa de polvo

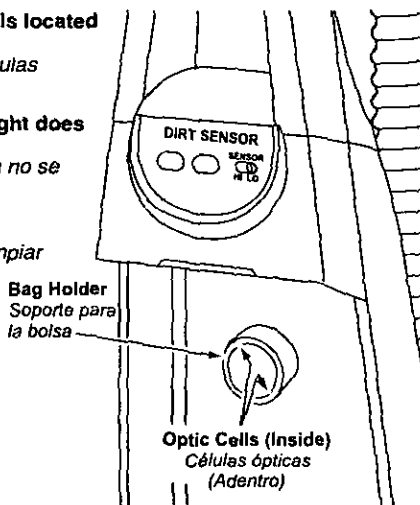

Cleaning Exterior and Tools

Limpieza del exterior y de los herramientas

- **Unplug cord from wall outlet**

Desenchufe de la toma en la pared

- **Clean exterior using a clean, soft cloth that has been dipped in a solution of mild liquid detergent and water and wrung dry**

Limpie la parte exterior con un trapo suave y limpio que se ha metido en una solución de detergente líquido y agua y se ha escurrido hasta que esté seco

- **DO NOT drip water on cleaner, wipe dry after cleaning**

No deje caer el agua en la aspiradora, seque con un trapo después de limpiarla

- **DO NOT clean tools in dishwasher or clothes washer**

No limpie las herramientas en el lavaplatos ni en la lavadora de ropa

- **Wash tools in warm soapy water, rinse and air dry**

Lave las herramientas en la tibia agua con jabón, enjuague y seque al aire

- **DO NOT use tools if they are wet**

No use las herramientas si están mojados

Removing Clogs

Quitar de los residuos de basura en los conductos

The hose located on the back of the vacuum cleaner carries the dirt from the nozzle up to the dust bag. If the hose should become clogged:

La manguera situada en la parte posterior de la aspiradora lleva el polvo de la boquilla hasta la bolsa de polvo. Si hay residuos en la manguera:

- **Unplug vacuum**
Desenchufe la aspiradora
- **Pull open suction inlet cover and check for clogging**
Tire de la cubierta de aspiración y revise por los residuos
- **Disconnect wand from short hose and check the wand and hose**
Desconecte el tubo de la manguera corta y revise por residuos en el tubo y en la manguera
- **Plug in vacuum cleaner and turn on**
Enchufe la aspiradora y enciéndala
- **Disconnect wand and stretch hose in and out to remove clog**
Desconecte el tubo y estire la manguera hasta la extensión máxima y mínima para quitar los residuos
- **If clog still exists, turn vacuum cleaner OFF and UNPLUG POWER CORD**
Si ya hay los residuos, apague la aspiradora y desenchufe el cordón eléctrico
- **Turn vacuum over and inspect agitator area for clogs**
Dé vuelta la aspiradora e inspeccione el agitador por impedimentos.

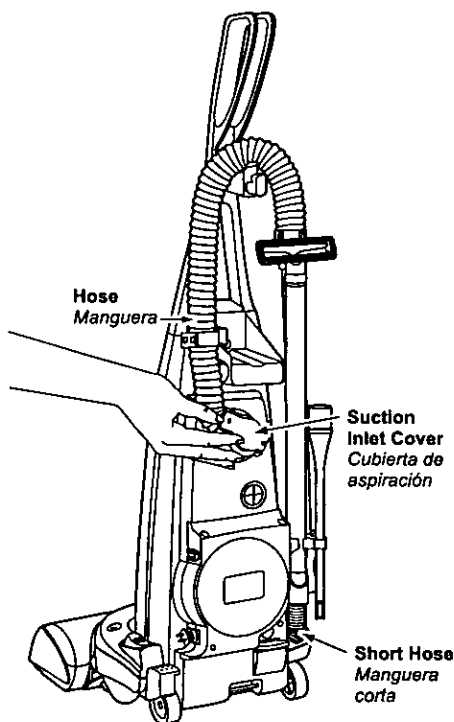

BEFORE REQUESTING SERVICE



WARNING *Electrical Shock or Personal Injury Hazard.*

Disconnect the electrical supply before servicing or cleaning the unit. Failure to do so could result in electrical shock or personal injury from cleaner suddenly starting.

Review this chart to find do-it-yourself solutions for minor performance problems. Any service needed, other than those described in these Operating Instructions, should be performed by an authorized service representative.

| PROBLEM | POSSIBLE CAUSE | POSSIBLE SOLUTION |
|------------------------------------|---|--|
| Cleaner will not run. | <ol style="list-style-type: none"> 1. Unplugged at wall outlet. 2. Tripped thermal protector. 3. ON-OFF switch not turned on. 4. Tripped circuit breaker/blown fuse at household service panel. | <ol style="list-style-type: none"> 1. Plug in firmly. Push ON-OFF switch to ON. 2. Reset thermal protector. 3. Push ON-OFF switch to ON. 4. Reset circuit breaker or replace fuse. |
| Poor job of dirt pickup. | <ol style="list-style-type: none"> 1. Full or clogged dust bag. 2. Agitator On-Off selector in wrong position. 3. Clogged hose or nozzle. 4. Hose not inserted fully. 5. Worn agitator. 6. Hole in hose. 7. Dust cover improperly installed. | <ol style="list-style-type: none"> 1. Change bag. 2. Set in the correct position. 3. Clean hose or nozzle area. 4. Insert hose. 5. Replace agitator. 6. Replace hose. 7. Properly install dust cover. |
| Agitator does not turn. | <ol style="list-style-type: none"> 1. Tripped agitator overload protector. 2. Tripped agitator thermal protector. 3. Vacuum in full upright position. 4. Agitator On-Off selector in off position. | <ol style="list-style-type: none"> 1. Reset agitator overload protector. 2. Reset agitator thermal protector. 3. This is normal. Agitator will not rotate in full upright position. 4. Push selector to ON. |
| Dust escapes the paper bag. | <ol style="list-style-type: none"> 1. Bag improperly installed. 2. Bag torn. | <ol style="list-style-type: none"> 1. Properly install bag. 2. Replace bag. |
| Light will not work. | <ol style="list-style-type: none"> 1. Burned out light bulb. | <ol style="list-style-type: none"> 1. Replace light bulb. |
| Dirt sensor will not work. | <ol style="list-style-type: none"> 1. Dirty optic cells. | <ol style="list-style-type: none"> 1. Clean optic cells. |

WARRANTY

Panasonic Vacuum Cleaner Limited Warranty

Panasonic Consumer Electronics Company or Panasonic Sales Company (collectively referred to as "the warrantor") will repair this product with new or refurbished parts free of charge, in the U.S.A. or Puerto Rico for one (1) year from the date of original purchase in the event of a defect in materials or workmanship.

This Limited Warranty Excludes both Labor and Parts for the following items which require normal replacement: Disposable Dust Bag, Filters, Belts, Light Bulbs, Agitator Brushes and Batteries (if supplied).

Carry-in or mail-in service in the U.S.A. or Puerto Rico can be obtained during the warranty period by contacting a Panasonic Services Company (PASC) Factory Servicenter listed in the Servicenter Directory. Or call, toll free, 1-800-211-PANA (7262) to locate a PASC Authorized Servicenter. Carry-in or mail-in service in Puerto Rico can be obtained during the warranty period by calling the local Panasonic Sales Company telephone number listed in the Servicenter Directory.

This warranty is extended only to the original purchaser. A purchase receipt or other proof of date of original purchase will be required before warranty performance is rendered.

This warranty only covers failures due to defects in materials and workmanship which occur during normal use and does not cover damages which occur in shipment, or failures which are caused by products not supplied by the warrantor, or failures which result from accident, misuse, abuse, neglect, mishandling, misapplication, faulty installation, improper operation or maintenance, alteration, modification, power line surge, improper voltage supply, lightning damage, commercial use such as hotel, office, restaurant or other business or rental use of the product, or service by anyone other than a PASC Authorized Servicenter, or damage that is attributable to acts of God.

LIMITS AND EXCLUSIONS:

There are no express warranties except as listed above.

THE WARRANTOR SHALL NOT BE LIABLE FOR INCIDENTAL OR CONSEQUENTIAL DAMAGES RESULTING FROM THE USE OF THIS PRODUCT, OR ARISING OUT OF ANY BREACH OF THIS WARRANTY. ALL EXPRESS AND IMPLIED WARRANTIES, INCLUDING THE WARRANTIES OF MERCHANTABILITY AND FITNESS FOR A PARTICULAR PURPOSE, ARE LIMITED TO THE APPLICABLE WARRANTY PERIOD SET FORTH ABOVE.

Some states do not allow the exclusion or limitation of incidental or consequential damages, or limitations on how long an implied warranty lasts, so the above exclusions or limitations may not apply to you.

This warranty gives you specific legal rights and you may also have other rights which vary from state to state. If a problem with this product develops during or after the warranty period, you may contact your dealer or Servicenter. If the problem is not handled to your satisfaction, then write to the Customer Satisfaction Center at the listed address on the back cover.

WHAT TO DO WHEN SERVICE IS NEEDED

Quando necesita servicio

If your Panasonic Vacuum Cleaner needs service, look in the yellow pages of the telephone book under HOME APPLIANCE SERVICE for your nearest Panasonic Services Company ("PASC") Factory Servicenter, or PASC authorized Servicenter, or call, 1-800-211-PANA (7262) toll free to find a convenient servicenter. DO NOT send the product to the Executive or Regional Sales offices. They are NOT equipped to make repairs.

Si su aspiradora Panasonic necesita servicio, busque el Centro de Servicio Panasonic o un Centro de Servicio PASC autorizado más cercano bajo "Servicio de Electrodomésticos" en las páginas amarillas de la guía de teléfonos o llame gratis al 1-800-211-PANA (7262) para encontrar un centro de servicio conveniente. No mande el producto a las Executive o Regional Sales Offices. No están equipadas para arreglar estos productos.

If you ship the product

Carefully pack and send it prepaid, adequately insured and preferably in the original carton. Attach a postage-paid letter to the outside of the carton, which contains a description of your complaint. DO NOT send the product to the Executive or Regional Sales Offices. They are NOT equipped to make repairs.

Si manda el producto

Empaquete con cuidado en el cartón original si posible y mándelo prepagado y con seguro suficiente. Ponga una carta con sellos en la que describe su problema con el producto en el exterior del cartón. No mande el producto a las Executive o Regional Sales Offices. No están equipadas para arreglar estos productos.

Customer's Record / *Récord de Comprador*

Model No. / Dealer's Name /
Número de Modelo _____ Nombre del Vendedor _____

Serial No. / Número de Serie _____

Dealer's Address / Dirección del Vendedor _____

Date of Purchase / Fecha de Compra _____

PANASONIC CONSUMER ELECTRONICS
COMPANY, DIVISION OF MATSUSHITA ELECTRIC
CORPORATION OF AMERICA

One Panasonic Way
Secaucus, New Jersey 07094

PANASONIC SALES COMPANY,
MATSUSHITA ELECTRIC OF
PUERTO RICO INC.

Ave. 65 de infantería, Km 9.5
San Gabriel Industrial Park
Carolina, Puerto Rico 00985

ACØ1ZBBSZØU
CØ1ZBBSØØUØØ

Printed in U.S.A.
Impreso en EUA