

Operating Instructions

VACUUM CLEANER
MC-V9620

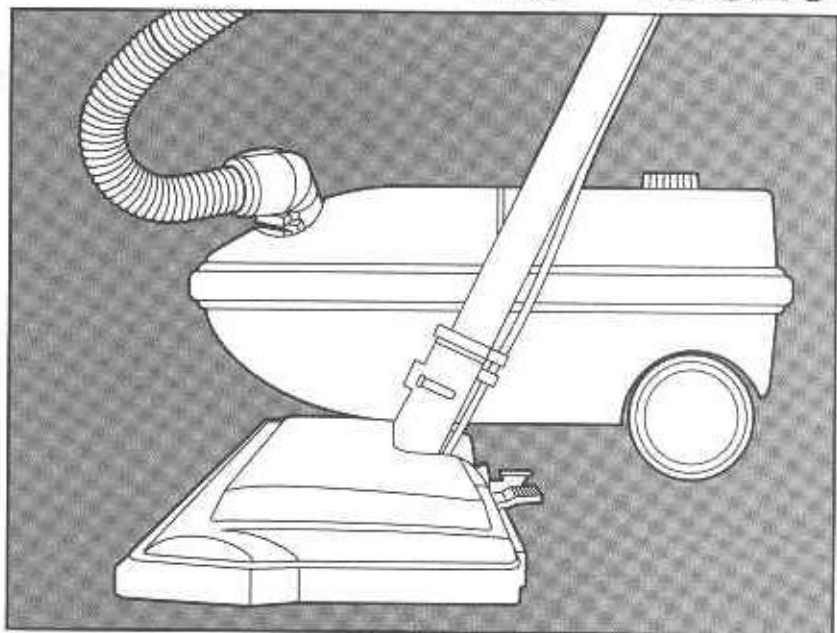

Panasonic®

Before operating this unit, please read these instructions completely.

TABLE OF CONTENTS

Safety Instructions	1
Parts Identification and Features Chart.....	2
Vacuum Cleaner Assembly	3-4
How Your Vacuum Works	4
Use - How To Start	5
Suggested Pile Height Settings.....	5
Handle Switch.....	5
Attachments and Use	6
Performance Features - Overload Protector, Suction Control, Hose Swivel, and Performance Indicator	7
Vacuuming Tips.....	7
Bag Changing and Motor Safety Filter Cleaning	8
Cleaning Exterior and Attachments.....	9
POWER NOZZLE Care - Light Bulb Changing, Belt Changing and Agitator Cleaning	9-10
Brush Servicing and Agitator Exploded View	11
Troubleshooting	12
Warranty	17
Service Information	Back Cover

CONSUMER INFORMATION

VCMA Vacuum Cleaner Manufacturer's Association

Service to the Industry since 1913 (Panasonic – An Association Member)

This information has been compiled by the Vacuum Cleaner Manufacturer's Association from Government and Private Sources concerned with product safety. These basic guidelines are for your protection and convenience.

Proper assembly and safe use of your vacuum cleaner are your responsibilities. Your cleaner is intended only for household use. The cleaner should be stored in a dry, indoor area. Read the Operating Instructions carefully for important use and safety information.



WARNING

TO AVOID ELECTRIC SHOCK

Never vacuum damp or wet surfaces or liquids.
Do not store machine outdoors.
Replace worn or frayed power cord immediately.

TO AVOID ACCIDENTS

Except for hand-held cleaners, keep machine on floor – not on chairs, tables, etc.
Store machine promptly after each use to prevent accidents from tripping over power cord or machine.
Use machine and accessories only in manner intended by manufacturers.
The use of an extension cord is not recommended.

IMPORTANT SAFETY INSTRUCTIONS

When using vacuum cleaner, basic precautions should always be followed, including the following:

READ ALL INSTRUCTIONS BEFORE USING THIS VACUUM CLEANER

WARNING

To reduce the risk of fire, electric shock, or injury:

1. Do not leave vacuum cleaner when plugged in. Unplug from outlet when not in use and before servicing.
2. To reduce the risk of electric shock – DO NOT use outdoors or on wet surfaces.
3. Do not allow to be used as a toy. Close attention is necessary when used by or near children.
4. Use only as described in this manual. Use only manufacturer's recommended attachments.
5. Do not use with damaged cord or plug. If vacuum cleaner is not working as it should, has been dropped, damaged, left outdoors, or dropped into water, return it to an authorized Panasonic Service Center.
6. Do not pull or carry by cord, use cord as a handle, close a door on cord, or pull cord around sharp edges or corners. Do not run vacuum cleaner over cord. Keep cord away from heated surfaces.
7. Do not unplug by pulling on cord. To unplug, grasp the plug, not the cord.
8. Do not handle plug or vacuum cleaner with wet hands.
9. Do not put any object into openings. Do not use with any opening blocked; keep free of dust, lint, hair and anything that may reduce air flow.
10. Keep hair, loose clothing, fingers, and all parts of body away from openings and moving parts.
11. Do not pick up anything that is burning or smoking, such as cigarettes, matches or hot ashes.
12. Do not use without dust bag and/or filters in place.
13. Turn off all controls before unplugging.
14. Use extra care when cleaning on stairs.
15. Do not use to pick up flammable or combustible liquids such as gasoline or use in areas where they may be present.
16. Always turn cleaner off before connecting or disconnecting the hose or Power Nozzle.

SAVE THESE INSTRUCTIONS

THIS VACUUM CLEANER IS INTENDED FOR HOUSEHOLD USE ONLY

Notice: Before you plug in your Panasonic Vacuum Cleaner, make sure that the voltage indicated on the rating plate located on the bottom of the vacuum cleaner is the same as your local supply.

PARTS IDENTIFICATION

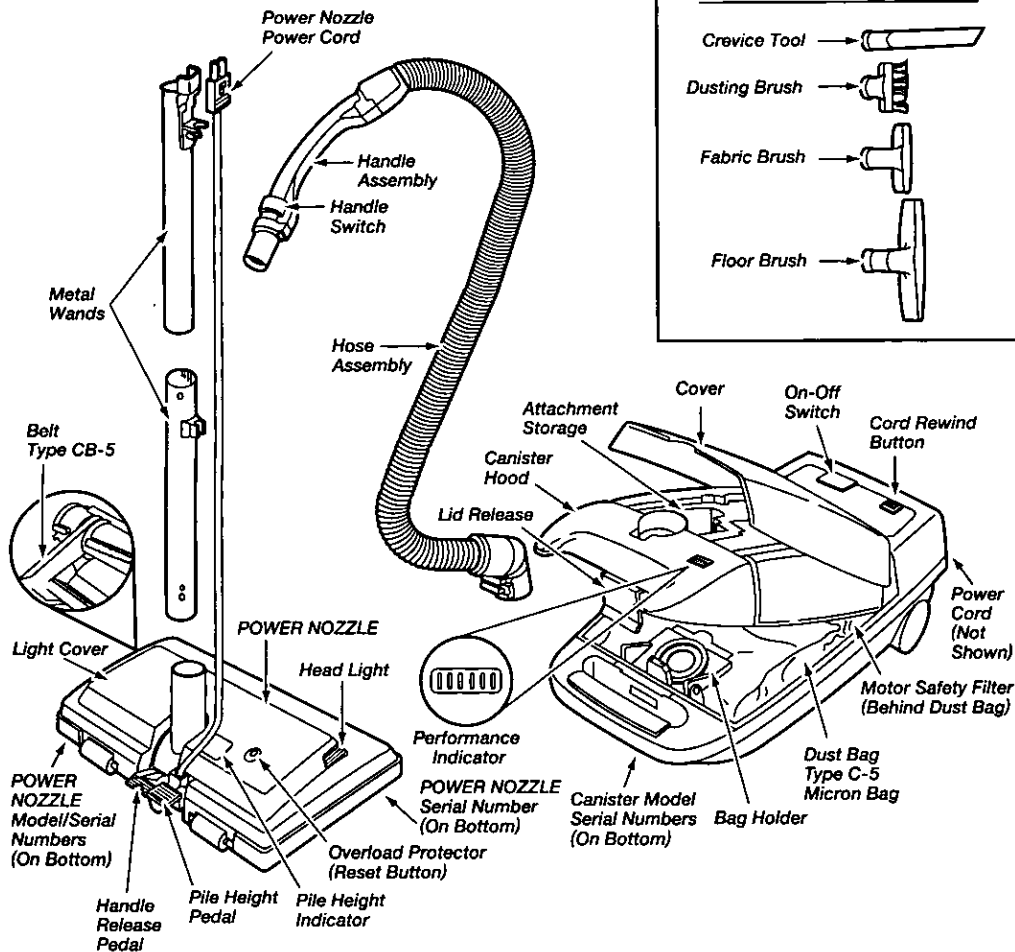

ATTACHMENTS

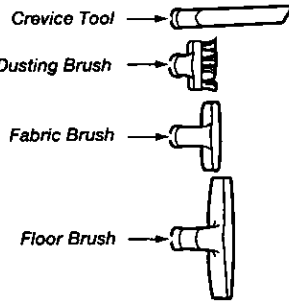

FEATURE CHART

(PANASONIC CANISTER TYPE VACUUM CLEANER)

FEATURES	POWER	OVERLOAD PROTECTOR	HEADLIGHT	CORD LENGTH	TOOLS	POWER NOZZLE
Model				(feet)		
MC-V9620	120V. AC(60Hz) 11.0 Amps	Yes	Yes	20	Yes	Yes

VACUUM CLEANER ASSEMBLY



WARNING *Electrical Shock Hazard.*

- *Do not plug into electrical supply until assembly is complete. Doing so could result in electrical shock or injury.*
- *Do not get the power cord caught under the agitator when using the cleaning tools. Keep cord out from under POWER NOZZLE when vacuuming.*

Before assembling your vacuum cleaner, be sure you have all parts shown on page 2.

WANDS POWER NOZZLE

Slide wands together until wand button snaps into place.

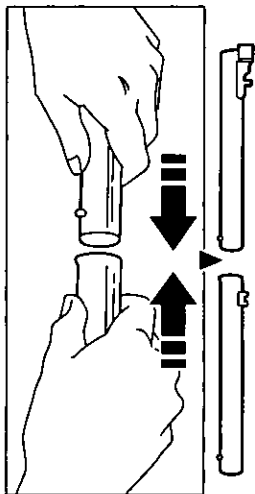

POWER NOZZLE

1. Insert wands into POWER NOZZLE until the wand button snaps into the grooved slot.

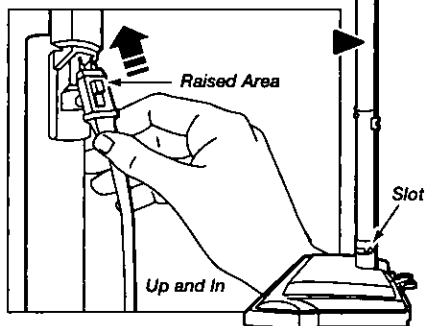

Connect POWER NOZZLE plug and cord as shown. **Do not force.** If hard to install, turn the plug over and try again.

CANISTER

1. Open the canister hood by gripping the lid release. Pull out and up to open hood. See page 2 for location of lid release.

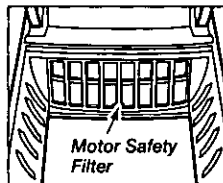

2. Check the dust bag. See page 8 for installation instructions.
3. Check motor safety filter. See page 8 for installation instructions.

ASSEMBLY

(continued)

HOOD-TOOL STORAGE

It is normal for the canister hood to come off when opened further than needed. Line up the hinges, insert them, and close the hood to replace it.

HOSE

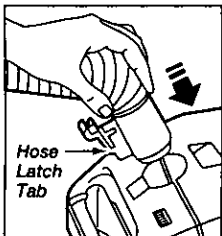

1. Insert hose into canister until it snaps in place.

TO REMOVE: Lift hose latch tab upward and pull up on hose.

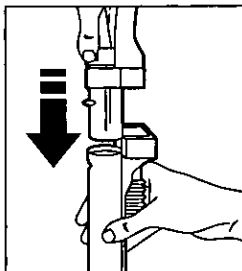

2. Insert handle into wand until lock button snaps in place. **Be sure hose is not twisted.**

TO REMOVE: Press handle release button and pull up on handle.

HOW YOUR VACUUM WORKS

The vacuum cleaner creates suction that picks up dirt. Rapidly moving air carries the dirt to the dust bag through the airflow passage. The dust bag lets the air pass through, while it traps the dirt.

For best cleaning results, keep the airflow passage open. Check the starred areas occasionally for clogs.

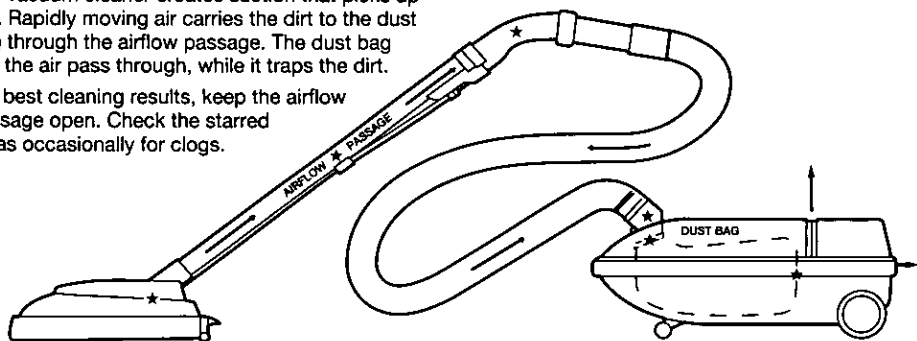

USE - HOW TO START



WARNING *Personal Injury and Product Damage Hazard*

- **DO NOT plug in if switch is in ON position. Personal injury or damage could result.**
- **The cord moves rapidly when rewinding. Keep children away and provide a clear path when rewinding the cord to prevent personal injury.**
- **DO NOT use outlets above counters. Damage to items in surrounding area could occur.**

NOTE: To reduce the risk of electric shock, this vacuum cleaner has a polarized plug, (one blade is wider than the other). This plug will fit in a polarized outlet only one way. If the plug does not fit fully in the outlet, reverse the plug. If it still does not fit, contact a qualified electrician to install the proper outlet.
DO NOT CHANGE THE PLUG IN ANY WAY.

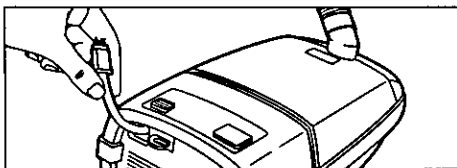

1. Pull cord out of canister to desired length.

2. Snap cord into grip to prevent accidental rewinding.

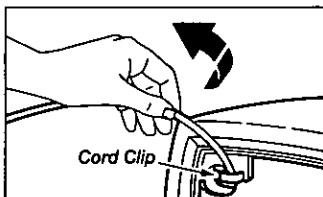

3. Plug cord into 120-volt outlet located near the floor.

TO REWIND: Remove the cord from the cord grip. Unplug the cleaner. Hold the plug while rewinding to prevent damage or injury from the moving cord. Push cord rewind button. The cord will not rewind until the cord rewind button is pushed.

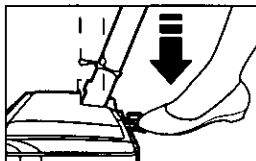

4. Lower wand from upright position by pressing on the handle release pedal.

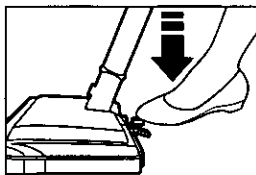

5. Select a pile height setting by pressing the small pedal on the rear. The pile height setting is shown in the window.

SUGGESTED PILE HEIGHT SETTINGS

For best deep down cleaning, use the **XLO** setting. However, you may need to raise the height to make some jobs easier, (such as scatter rugs and some deep pile carpets) and to prevent the vacuum cleaner from shutting off. Suggested settings are: **XLO**—most carpets and bare floors. **LO**—low to medium pile. **MED**—medium to deep pile. **HI**—shag; deep pile; scatter rugs.

1. Press "ON-OFF" switch to start canister and POWER NOZZLE.

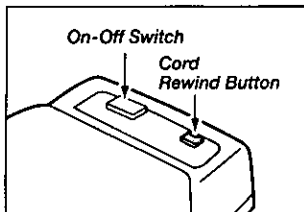

HANDLE SWITCH

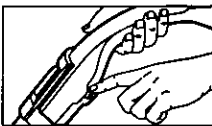

2. There are two positions on the handle, **Bare Floor/Off** and **Carpet**. **Bare Floor/Off** position turns on the Power Nozzle to be

used on uncarpeted floors. The Canister motor only will run. **Carpet** position turns on both the Canister motor and the Power Nozzle motor for normal carpet cleaning.

ATTACHMENTS AND USE



CAUTION

DO NOT attach or remove handle or wands while cleaner is ON. This could cause sparking and damage the electrical contacts.

ATTACHMENTS ON HANDLE

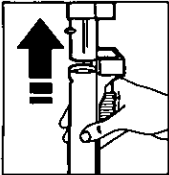

NOTE: If the POWER NOZZLE is attached, turn cleaner off before removing handle from wands.

1. Press lock button, then pull to remove handle from wand.

2. Slide attachments firmly on handle as needed (See chart on this page.)

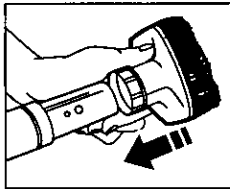

ATTACHMENTS ON WANDS

NOTE: If the POWER NOZZLE is attached, turn cleaner off before removing plug from wands.

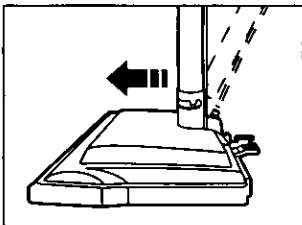

1. To remove wands from POWER NOZZLE, lock wands in straight-up position.

2. Remove POWER NOZZLE plug and cord from holders.

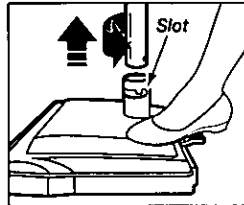
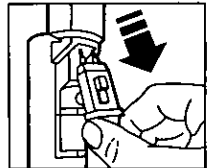

3. Steady POWER NOZZLE with foot and turn wands counterclockwise until lock button disappears, then pull wands out of POWER NOZZLE.

4. Put attachments on wands as needed. (See chart on this page.)

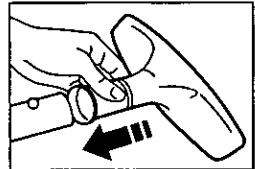





WARNING

Personal Injury Hazard

Use care if canister is placed on stairs. If it falls, personal injury or property damage could result.

ATTACHMENT USE

ATTACHMENT	CLEANING AREA							
	Furniture*	Between Cushions*	Drapes*	Stairs	Bare Floors	Carpeted Floors	Rugs	Walls
DUSTING BRUSH 	X		X					X
CREVICE TOOL 	X	X						
FABRIC BRUSH 	X		X					
FLOOR BRUSH 				X	X			X
POWER NOZZLE 						X	X	

*Always clean attachments before using on fabrics.

PERFORMANCE FEATURES

OVERLOAD PROTECTOR- POWER NOZZLE

The overload protector stops the motor when the brush jams and prevents belt breakage.

TO CORRECT PROBLEM:

1. Unplug electrical cord.
2. Check brush and brush support areas for excessive lint build-up or jamming.
3. Clean jammed area. (See pages 9-10).

TO RESET: Press reset button on top of the POWER NOZZLE. Plug in and turn on cleaner.

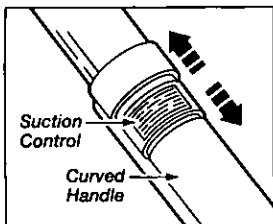

SUCTION CONTROL

The suction control increases or decreases the suction for different fabric and carpet weights. Opening the

control decreases suction for draperies and lightweight rugs. Closing the control increases suction for furniture and carpets.

HOSE SWIVEL

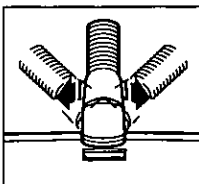

The hose swivel allows the hose to turn without moving the canister. This is helpful for cleaning in small areas. Check hose for twisting before pulling canister.

PERFORMANCE INDICATOR

When the unit is running the lines in the indicator windows will be clear if there are no clogs. When the lines turn completely red there is a need to check the dust bag for being full or the other areas that may be clogged. See page 4.

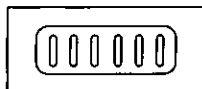

NOTE: Red lines may appear when using attachments or when cleaning new carpet, due to reduced air flow by the attachments themselves or new carpet fuzz filling the bag quickly.

VACUUMING TIPS

Suggested sweeping pattern.

For best cleaning action, the POWER NOZZLE should be pushed straight away from you and pulled straight back. At the end of each pull stroke, the direction of the POWER NOZZLE should be changed to point into the next section to be cleaned. This pattern should be continued across the rug with slow, gliding motions.



NOTE: Fast, jerky strokes do not provide complete cleaning.

Small areas can be cleaned without moving the canister. The hose swivel allows the hose to turn from side to side while the canister stays in place. Check hose for twisting before pulling canister.

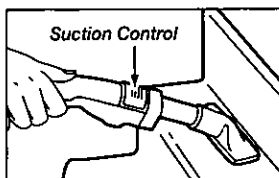
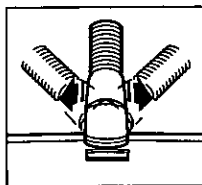

Carpeted stairs need to be vacuumed regularly. For best cleaning results, fully close the suction control.

BAG CHANGING

For best cleaning results, the dust bag should be changed often. Use Panasonic micron dust bag type C-5

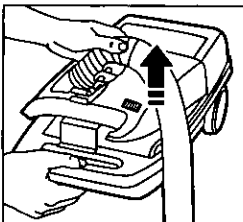

1. Unplug cord from wall outlet.
2. Pull lid release out and up, then lift canister hood.

5. The red bag mount will flip forward after removing bag. This will prevent the lid from closing until a new bag is installed.

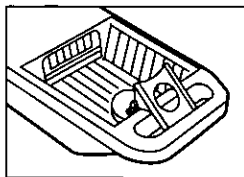

6. Raise red bag mount up.

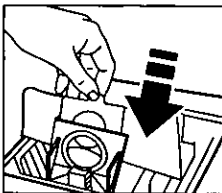

7. Install bag into slots pushing down until the cardboard tab locks into position and the holes align.

8. Close and latch canister hood.

9. Plug cord into wall outlet.

10. Bags are available at Panasonic Dealers and Distributors.

3. Remove cardboard tab from red bag mount by pressing away and lifting up.

4. Pull bag out of the red bag mount.

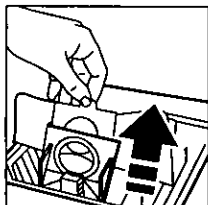

CAUTION

NEVER REUSE A DUST BAG. *Very fine materials, such as carpet fresheners, face powder, fine dust, plaster, soot, new carpet lint, etc. can clog the bag and cause it to burst before it is full. Change bag more often when vacuuming these materials.*

MOTOR SAFETY FILTER CLEANING

Check motor safety filter occasionally and clean when dirty.



WARNING *Electrical Shock Hazard*

Do not operate the cleaner without the motor safety filter. Be sure the filter is dry and properly installed to prevent motor failure and/or electrical shock.

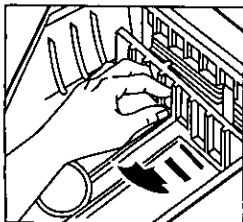

1. Unplug cord from wall outlet and remove bag.
2. Pull out safety filter as shown.
3. Wash filter in warm soapy water, rinse, then air dry.

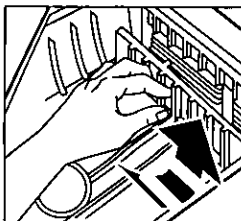

- Do not clean in dishwasher or install while damp.**
4. Snap filter back into canister.
 5. Install bag.

CLEANING EXTERIOR AND ATTACHMENTS

1. Unplug cord from wall outlet. **DO NOT drip water on cleaner.**
 2. Clean exterior using a clean, soft cloth that has been dipped in a solution of mild liquid detergent and water, then wrung dry. Wipe dry after cleaning.
 3. To reduce static electricity and dust build-up, wipe outer surface of canister and attachments.
 4. Wash attachments in warm soapy water, rinse and air dry. **Do not clean in dishwasher.**
- DO NOT USE ATTACHMENTS IF THEY ARE WET.**



CAUTION

Attachments used in dirty areas (under a refrigerator) should not be used on other surfaces until they are washed. They could leave marks.

POWER NOZZLE CARE

Always follow all safety precautions when cleaning and servicing the POWER NOZZLE.



WARNING *Electrical Shock Or Personal Injury Hazard*

Disconnect electrical supply before servicing or cleaning the unit. Failure to do so could result in electrical shock or personal injury from cleaner suddenly starting.

LIGHT BULB CHANGING

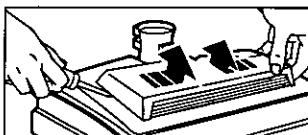

side of the light cover up. After freeing one side, lift up to remove.

1. To remove light cover use a flat blade screwdriver, gently prying one

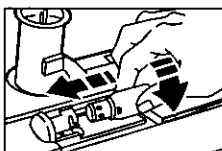

2. Push in and turn bulb to remove.
3. Replace the bulb with a standard bayonet type appliance bulb rated 120V/15W.

To replace cover, fit the rear tabs into the rear of the housing and press the sides down until it snaps in place.



CAUTION

Do not use a bulb rated over 15W. During extended use, heat from the bulb could overheat the surrounding plastic parts.

BELT CHANGING AND AGITATOR CLEANING

Disconnect cleaner from electrical outlet. Check and remove hair, string and lint build-up frequently in the POWER NOZZLE brush and agitator support areas. If build-up becomes excessive, disconnect POWER NOZZLE from wand and follow the steps on page 10.

TO REMOVE BELT

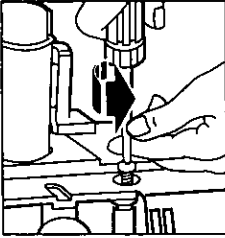

1. Remove light cover and light bulb as shown under "LIGHT BULB CHANGING."
2. Unscrew the two (2) POWER NOZZLE cover screws.

3. Turn POWER NOZZLE over. To remove cover, insert screwdriver at cover tabs on both sides and twist to release tabs.

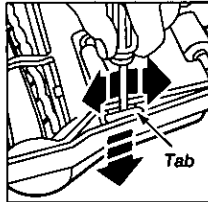

4. Turn POWER NOZZLE right side up. Press handle release pedal and lower the swivel. Tilt cover forward from back until front snaps free.

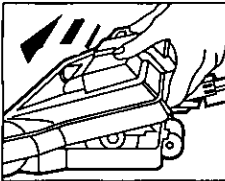

5. Carefully insert and twist screwdriver at each agitator support to free brush from base.

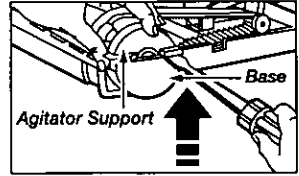

CAUTION

When you remove the agitator supports, a small metal washer on each end may come off. DO NOT lose these two metal washers.

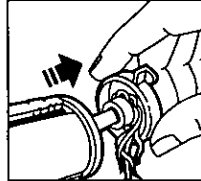

6. Remove worn belt.
7. Slide agitator supports off to check and clean agitator support areas. See page 11 for picture of complete agitator assembly.

TO REPLACE BELT

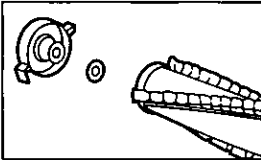

1. Slide washers and agitator supports onto agitator assembly.

2. Install new belt in belt groove on the agitator assembly, then over the motor shaft. Be sure belt is under the belt guard.

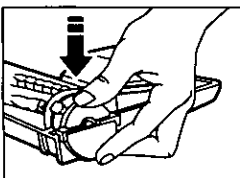
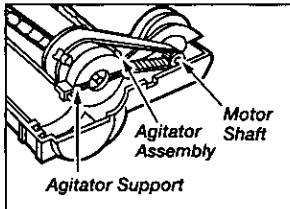

3. Insert both front support tabs into the base slots. Then snap agitator supports into place. See page 11.

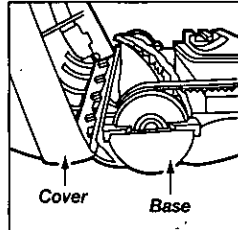

4. Line up front of cover and base. Rest cover on front edge of base as shown.

5. Tilt cover to back. Press cover firmly until rear tabs snap into place. Turn POWER NOZZLE over. Replace the cover screws and lower the pile height adjustment rollers into place. Replace light bulb and cover.

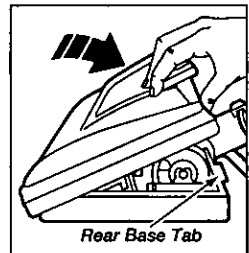

BRUSH SERVICING



WARNING *Electrical Shock Or Personal Injury Hazard*

Disconnect electrical supply before servicing or cleaning the unit. Failure to do so can result in electrical shock or personal injury from cleaner suddenly starting.

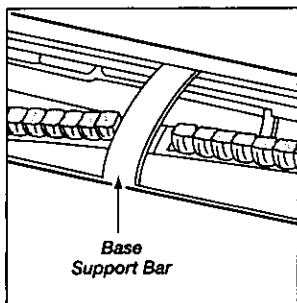

TO CHECK BRUSHES:

When brushes are worn to the level of the base support bars, replace the brushes.

TO REPLACE BRUSH AGITATOR UNIT:

1. Remove POWER NOZZLE cover, belt and agitator assembly. (See "TO REMOVE BELT" in "BELT CHANGING AND AGITATOR CLEANING" on pages 9-10).
2. Remove agitator supports, washers, screws, end brush, brush sprocket, and brush sprocket flange from ends of agitator assembly.
3. Replace belt, agitator assembly and POWER NOZZLE cover screws. (See "TO REMOVE BELT" in "BELT CHANGING AND AGITATOR CLEANING" on page 10).

AGITATOR ASSEMBLY

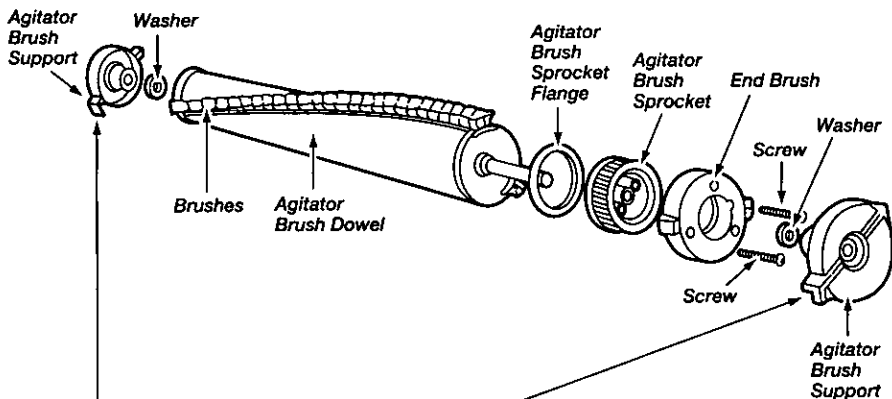

TROUBLESHOOTING

Review this chart to find do-it-yourself solutions for minor performance problems.



WARNING Electrical Shock Hazard

Disconnect electrical supply before servicing or cleaning the unit. Failure to do so could result in electrical shock or personal injury.

PROBLEM	POSSIBLE CAUSE	POSSIBLE SOLUTION
Cleaner won't start.	<ol style="list-style-type: none"> 1. Unplugged at wall outlet. 2. Tripped circuit breaker/blown fuse at household service panel. 3. Loose hose electrical connections. 4. Tripped Overload Protector in POWER NOZZLE. 5. On-Off switch not turned ON. 	<ol style="list-style-type: none"> 1. Plug in firmly, push On/Off switch to ON. 2. Reset circuit breaker or replace fuse. 3. Reconnect hose ends, (page 4). 4. Clean brush and brush supports, then reset, (pages 9,10,11). 5. Push On-Off switch to ON.
Poor job of dirt pick-up.	<ol style="list-style-type: none"> 1. Full or clogged dust bag or airflow blockage. 2. Dirty motor safety filter. 3. Wrong pile height setting. 4. Open suction control. 5. Hole in hose. 6. Worn POWER NOZZLE brushes. 7. Clogged POWER NOZZLE nozzle. 8. Clogged handle or hose. 9. Canister hood open. 10. POWER NOZZLE not running. 	<ol style="list-style-type: none"> 1. Change bag, (page 8) Clean airflow passage, (page 4). 2. Clean filter, (page 8). 3. Adjust setting, (page 5). 4. Adjust control, (page 7). 5. Replace hose. 6. Change agitator unit, (page 11). 7. Clean POWER NOZZLE air passage. 8. Clean air passage. 9. Close and latch hood. 10. Check overload protector button. Reset POWER NOZZLE, (page 7).
Cleaner starts but cuts off.	<ol style="list-style-type: none"> 1. Hose or hood electrical connections. 2. Tripped Overload Protector in POWER NOZZLE. 3. Motor too hot. 4. Full or clogged dust bag or airflow blockage. 	<ol style="list-style-type: none"> 1. Check connections, reconnect hose ends, (page 4). 2. Remove any items that may be caught or jammed, then reset, if the cleaner starts and stops again, clean brush and brush supports, then reset, (pages 9,10,11). 3. Wait 20 minutes for motor to cool. 4. Change dust bag, (page 8) Clear airflow blockage, (page 4). Wait 20 minutes for motor to cool.
POWER NOZZLE will not run when attached.	<ol style="list-style-type: none"> 1. POWER NOZZLE connections unplugged. 2. Worn or broken belt. 3. Dirty brush or brush supports. 4. Tripped Overload Protector in POWER NOZZLE. 	<ol style="list-style-type: none"> 1. Plug in firmly, (page 5). 2. & 3. See "BELT CHANGING AND BRUSH CLEANING," (pages 9,10,11). 4. Check brush area for excessive lint build-up or jamming. Clean brush and brush supports, then reset, (pages 9,10,11).
Cleaner picks up movable rugs -OR- POWER NOZZLE pushes to hard.	<ol style="list-style-type: none"> 1. Wrong pile height setting. 2. Suction too strong. 	<ol style="list-style-type: none"> 1. Adjust setting, (page 5). 2. Open suction control, (page 7).
Light won't work.	<ol style="list-style-type: none"> 1. Burned out bulb. 	<ol style="list-style-type: none"> 1. Change bulb, (page 9).
Cord won't rewind.	<ol style="list-style-type: none"> 1. Dirty power cord. 2. Cord locked in cord grip. 3. Cord jammed. 	<ol style="list-style-type: none"> 1. Clean the power cord. 2. Remove cord from grip. 3. Pull out cord and rewind.
Cleaner leaves marks on carpet.	<ol style="list-style-type: none"> 1. Wrong vacuuming pattern. 	<ol style="list-style-type: none"> 1. See "VACUUMING TIPS," (page 7).

WARRANTY

Panasonic Vacuum Cleaner Limited Warranty

MATSUSHITA CONSUMER ELECTRONICS COMPANY OR PANASONIC SALES COMPANY (collectively referred to as the warrantor) will repair this product with new or refurbished parts free of charge, in the U.S.A. or Puerto Rico one (1) year from the date of original purchase in the event of a defect in materials or workmanship. Excluded are the following items which require normal replacement: Disposable Dust Bag, Filters, Belts, Light Bulb, Agitator Brushes and Battery (if supplied).

Carry-in service in the continental U.S.A. can be obtained during the warranty period from a Matsushita Services Company (MSC) Factory Servicenter. To locate an authorized MSC Servicenter call 1-800-545-2672 toll free. Service in Puerto Rico can be obtained during the warranty period by calling the telephone numbers listed in the Servicenter Directory. This warranty is extended only to the original purchaser. A purchase receipt or other proof of date of original purchase will be required before warranty performance is rendered.

This warranty only covers failures due to defects in materials or workmanship which occur during normal use and does not cover damage which occurs in shipment or failures which are caused by products not supplied by the warrantor, or failures which result from accident, misuse, abuse, neglect, mishandling, misapplication, alteration, modification of the product, or commercial use such as hotel, office, restaurant or rental use of the product, or service by anyone other than an authorized Servicenter, or damage that is attributable to acts of God.

LIMITS AND EXCLUSIONS: There are no express warranties except as listed above.

The warrantor SHALL NOT BE LIABLE FOR INCIDENTAL OR CONSEQUENTIAL DAMAGES RESULTING FROM THE USE OF THIS PRODUCT, OR ARISING OUT OF ANY BREACH OF THIS WARRANTY. ALL EXPRESS AND IMPLIED WARRANTIES, INCLUDING THE WARRANTIES OF MERCHANTABILITY AND FITNESS FOR A PARTICULAR PURPOSE, ARE LIMITED TO THE APPLICABLE WARRANTY PERIOD SET FORTH ABOVE. Some states do not allow the exclusion or limitation of incidental or consequential damages or limitations on how long an implied warranty lasts, so the above exclusions or limitations may not apply to you.

This warranty gives you specific legal rights and you may also have other rights which vary from state to state.

If a problem with this product develops during or after the warranty period, you may contact your dealer or Servicenter. If the problem is not handled to your satisfaction, then write to the Customer Satisfaction Center at the address listed on the back cover.

WHAT TO DO WHEN SERVICE IS NEEDED

If your Panasonic Vacuum Cleaner needs service, look in the yellow pages of the telephone book under "Home Appliance Service" for your nearest Matsushita Service Company ("MSC") Factory Servicenter, or MSC authorized Servicenter, or call 1-800-545-2672, toll free to find a convenient servicenter. Do NOT send the product to the Executive of Regional Sales offices. They are NOT equipped to make repairs.

If you ship the product

Carefully pack and send it prepaid, adequately insured and preferably in the original carton. Attach a postage-paid letter to the outside of the carton, which contains a description of your complaint. **DO NOT send the product to the Executive or regional Sales office. They are NOT equipped to make repairs.**

Customer's Record

Model No. _____ Dealer's Name _____

Serial No. _____

Dealer's Address _____

Date of Purchase _____

Consumers requiring product information or operating assistance with a consumer product should contact:

CUSTOMER SATISFACTION CENTER DEPARTMENT 2F-3

50 Meadowlands Parkway
Secaucus, N.J. 07094
(201) 348-9090

**DIAL TOLL FREE
1-800-545-2672**

Matsushita Services Co.

**24 hours a day,
7 days a week**

**MATSUSHITA CONSUMER ELECTRONICS
COMPANY, DIVISION OF MATSUSHITA ELECTRIC
CORPORATION OF AMERICA**

One Panasonic Way
Secaucus, New Jersey 07094

**PANASONIC SALES COMPANY, DIVISION OF
MATSUSHITA ELECTRIC OF PUERTO RICO INC.
("PSC")**

AVE. 65 de Infanteria, Km. 9.5
San Gabriel Industrial Park
Carolina, Puerto Rico 00985
Tel. (809) 750-4300 Fax. (809) 768-2910