

This Owner's Manual is provided and hosted by [Appliance Factory Parts](#).



Capital Cooking Equipment PSQ30RC Owner's Manual

[Shop genuine replacement parts for Capital Cooking Equipment PSQ30RC](#)



[Find Your Capital Cooking Equipment Grill Parts - Select From 22 Models](#)

----- Manual continues below -----

USE AND CARE GUIDE
PERFORMANCE SERIES™
GAS GRILLS



THE POWER OF PERFORMANCE™

Message	i
Warnings	ii
Grill Models	iii
Safety Practices and Precautions	2-4
Natural Gas Requirements	5
LP (Propane) Gas Requirements	6
Leak Testing	7
Locating Grill	8
Built In Clearances	9
Light Connections	10
Burner Adjustments	11-12
Exclusive Features	13
Lighting Your Grill	14
Lighting Your Grill — Side Burners	16
Lighting the Rotisserie	17
Using the Rotisserie	18
PSQ Accessories	21
Helpful Hints	22
Caring for Your Grill	23
Troubleshooting	26
Service	27
Installer’s Final Checklist	28
Warranty	29
PSQ52RCSB Wiring Diagram	30
PSQ52RC Wiring Diagram	31
PSQ40RC Wiring Diagram	32
PSQ30RC Wiring Diagram	33
PSQ30BI Wiring Diagram	34
PSQSB2000 Wiring Diagram	35
Detailed Dimensional Specifications	36

capital cooking is your friend

hello and welcome to Capital...

We thank you for choosing our Performance Series™ cooking equipment. Because of the unique features found in our products, we recommend spending some time to familiarize yourself with this booklet before using your product. In it you will find valuable information on how to safely operate and maintain your appliance for years of enjoyable cooking.

We understand that questions arise from time to time on use and care about our products, so we want to make it easy for you to find the answers. That's why we pride ourselves on superior customer service and work harder to respond to your needs quickly and effectively.

Our Customer Service representatives are here to assist you and are just a phone call away. You can reach us toll free: 1-866-402-4600; by e-mail: customerservice@capital-cooking.com; or by standard mail: 13211 Florence Ave. Santa Fe Springs, CA, 90670.

When you contact us, please make sure you have the model # and your serial # ready. This allows us to better serve your needs.

We realize you have a choice in your appliance needs so we feel honored to welcome you to our family, where passion for improving the quality of your culinary life is our number one priority.

your friends at Capital Cooking Equipment.

WARNINGS!



read this:

This Appliance is FOR OUTDOOR USE ONLY!

WARNING!

If the information in this manual is not followed exactly, a fire or explosion may result, causing property damage, personal injury or death. Please read the installation, operating and maintenance instructions thoroughly before use.

WARNING!

Do not try lighting this appliance without reading the "Lighting Instructions" section in this manual. Improper installation, adjustment, alteration, service or maintenance can cause property damage, injury or death. Read the installation, operating and maintenance instructions thoroughly before use, installing or servicing this appliance. This outdoor gas appliance is not intended to be installed in or on recreational vehicles and/or boats!

PRECAUTION!

Do not store or use gasoline or any other flammable liquids in the vicinity of this or any other appliance.

FOR YOUR SAFETY!

If You Smell Gas:

Shut off gas to the appliance

Extinguish any open flames

If odor persists, immediately call your gas supplier

NOTE—Installation and service must be performed by qualified installer, service agency or the gas supplier.

**PLEASE RETAIN THIS MANUAL
FOR FUTURE REFERENCE!**

important technical info:

Tested in accordance with ANSI Z21.58b CAN/CGA 1.6b-2002 For US and Canada for LP and Natural Gas.
STANDARD FOR OUTDOOR USE ONLY.

Check your local building codes for the proper method of installation. In the absence of local codes, this unit should be installed in accordance with the National Fuel gas Code No. Z223.1-1998 and the National Electrical Code ANSI/NFPA No. 70-1990

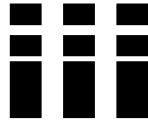

30"

**PSQ30ZRBI
PSQ30RBI**

**PSQ30ZRC
PSQ30RC**

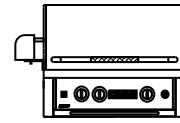
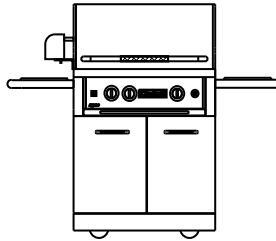

40"

**PSQ40RBI
PSQ40RC**

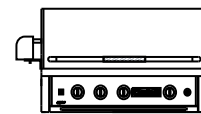
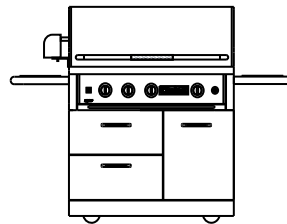

52"

**PSQ52RBI
PSQ52RSBI
PSQ52RC
PSQ52RCSB**

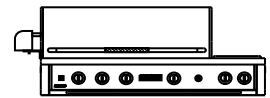
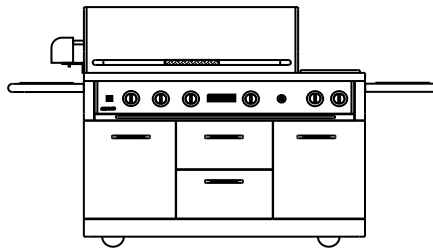

KEY:

*R = Rotisserie
BI = Built In
SB = Side Burner
Z = Infrared-Zone Burner
C = Cart
L = LP Unit
N = Natural Gas unit*

Therefore:

*RBIN = Rotis/Built In/Natural gas
RCSBL = Rotis+Cart+Side Burner/LP
ZRC = Infrared-Zone+Rotis+Cart
Etc., Etc., Etc.*

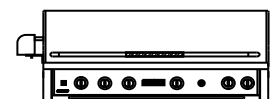
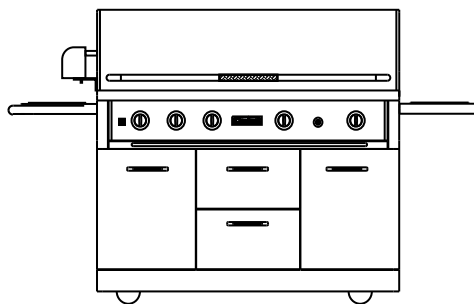

WE HOPE YOU UNDERSTAND:
Damage caused by a failure to heed warnings, follow basic safety instructions, or basic safety practices ARE NOT covered by the warranty.

■ **WARNING!**

When in use, portions of this appliance get hot enough to cause severe burns. Children and pets should never be left alone or unattended in an area where the appliance is being used. Never allow children to sit, stand, or play on or around the Grill or Side Burner at any time.

■ **IMPORTANT!**

Improper use or installation is dangerous. Carefully follow these instructions.

■ When properly cared for, your Performance Series™ grill or side burner will give you years of safe and reliable enjoyment. However, extreme care must be taken since this appliance produces intense heat, increasing the risk of accident potential. When using the grill, basic safety practices must be followed, including the following:

■ To reduce the risk of fire, burns, or other injury, read this Use and Care guide thoroughly. Begin by ensuring proper installation and servicing. Do not repair or replace any part of the grill or side burner unless specifically recommended in this manual. All other service must be referred to a qualified Factory Authorized Technician, call us at 1-866-402-45600 for details.

■ DO NOT store items of interest to children in or around the grill or side burner. Never allow children to use the Performance Series™ grill or side burner.

■ NEVER let clothing, pot holders or other flammable materials come into contact with or come too close to any grate, burner or hot surface until it has cooled. Fabric may ignite and result in personal injury.

■ DO NOT heat unopened food containers as a build up of pressure may cause the container to burst

■ NEVER lean on an open grill or side burner. When lighting a burner, always pay close attention to what you are doing. Be certain you are pushing the ignition button when you attempt to light the burner.

■ DO NOT touch the grill grates (racks) or side burner grate, or any item in the interior cavity or surrounding area of the appliance when burners are on. These areas become extremely hot and could cause severe burns.

■ GREASE is flammable. Let hot grease cool before attempting to handle it.

■ DO NOT line grill or side burner grates with aluminum foil. This may severely disrupt combustion airflow or trap excessive heat in the controlled area. This may result in melted knobs and/or igniters, and damage to the lighting system

■ TAKE CAUTION when cleaning the grill or side burner. Avoid steam burns: Do not use a wet sponge or cloth to clean any surface while it is hot. Some cleaners produce noxious fumes or can ignite if applied to a hot surface.

- **BE SURE** all control knobs are in the OFF position and grill or side burner is cool prior to using any aerosol cleaner on or around it. The chemical that produces the spraying action could, in the presence of heat, ignite or cause metal parts to corrode.
- **ALWAYS** use dry potholders: moist or damp potholders on hot surfaces may cause steam burns. Do not use a towel or bulky cloth in place of potholders. **DO NOT** let potholders touch hot portions of the Side Burner grate or burner.
- **DO NOT** operate the grill or side burner under unprotected combustible construction. Use only in well ventilated area. **DO NOT** obstruct the flow of combustion and ventilation air.
- **DO NOT** use the grill or side burner in buildings, garages, sheds, breezeways or other such enclosed areas. This unit is for Outdoor Use Only!
- **KEEP ALL** electrical cords away from the heated areas of this appliance.
- **BEGIN** by ensuring proper installation and servicing. Follow the installation instructions provided with this product. Have your grill or side burner installed by a qualified technician. Have the installer show you where the gas supply shut off valve is located, so that you know where to shut off the gas to the grill.
- **IF YOU SMELL GAS**, your installer has not done a proper job of checking for leaks. If the connections are not perfectly sealed, you can have a small leak and therefore a faint gas smell. Finding a leak is not a “do-it-yourself” procedure. Some leaks can only be found with the burner control in the “ON” position, and this must be done only by a qualified technician.

■ **IMPORTANT SAFETY NOTICE REGARDING LP TANKS:**

Certain Liquid Propane dealers may fill liquid propane cylinders for use in the grill or side burner beyond cylinder filling capacity. This “Overfilling” may create a dangerous condition.

“Overfilled” tanks can build up excess pressure. As a safety device, the tank’s pressure relief valve will vent propane gas vapor to relieve this excess pressure. This vapor is combustible and therefore can be ignited. To reduce this danger, you should take the following safety precautions:

1. When you have your tank filled, be sure you tell the supplier to fill it to no more than 3/4 (75%) of its total filling capacity.
2. If you own or use an extra tank, or have a disconnected tank, you should never store it near or under the grill unit or heat box, or near any other ignition or heat source.

BE SAFE!

4

WARNING!:

Keep the area surrounding the grill free from combustible materials, trash, or combustible fluids and vapors such as gasoline or charcoal lighter fluid. DO NOT obstruct the flow of combustion and ventilation air.

WARNING!:

NEVER use the grill in windy conditions. If located in a consistently windy area (oceanfront, mountaintop, etc.) a windbreak will be required. Always adhere to specific clearances listed.

IMPORTANT:

Never use a dented or rusty LP tank.

A NOTE ON CLOTHING:

For personal safety, wear proper apparel. Loose fitting garments or sleeves should never be worn while using this appliance. Some synthetic fabrics are highly flammable and should not be worn while cooking.

A NOTE ON COOKWARE:

Only certain types of glass, heat-proof glass ceramic, earthenware, or other glazed utensils are suitable for grill use. Use of these types of materials may break with sudden temperature changes. Use only on low or medium heat settings according to the manufacturer's directions.

IMPORTANT:

SPIDER AND INSECT WARNING!

Spiders and insects can nest in the burners of this and any other grill, and cause the gas to flow from the front of the burner. This is a very dangerous condition that can cause a fire to occur behind the valve panel, thereby damaging the grill and making it unsafe to operate.

please do this!

- When using the open top burners, always use flat-bottomed utensils large enough to cover the burner. Adjust the flame so that it heats only the bottom of the pan to avoid ignition of clothing. Position handles inward, away from open edges of the unit to avoid burns associated with unintentional spillovers. Hold the handle of the pan to prevent movements of the utensil when turning or stirring food. For proper lighting and performance of the burners, keep the burner ports clean. It is necessary to clean them periodically for optimum performance.
- Keep the Performance Series (TM) grill covered when not in use. Never connect an unregulated gas line to the grill. If the grill has not been used for an extended period of time (over winter, for example), the unit should be checked for gas leaks and obstructions in the burner. Thoroughly clean the Performance Series™ grill on a regular basis.
- Only use the Performance Series™ grill with the type of gas specified on the rating plate. To change from LP gas to natural, a factory conversion kit is available for purchase (see your Capital authorized dealer for details)
- Please inspect the burner(s) at least once a year or immediately if any of the following conditions are present:
 - The smell of gas in conjunction with the burner flames appearing yellow.
 - The grill does not reach temperature.
 - The burner(s) makes popping noises.

important governmental stuff:

CALIFORNIA PROPOSITION 65-WARNING:

The burning of gas cooking fuel generates some by-products that are on the list of substances which are known by the State of California to cause Cancer or reproductive harm. California law requires businesses to warn customers of potential exposure to such substances. To minimize exposure to these substances, always operate this unit according to the Use and care Guide, ensuring you provide good ventilation when cooking with gas.

natural gas requirements: — 5

do this...

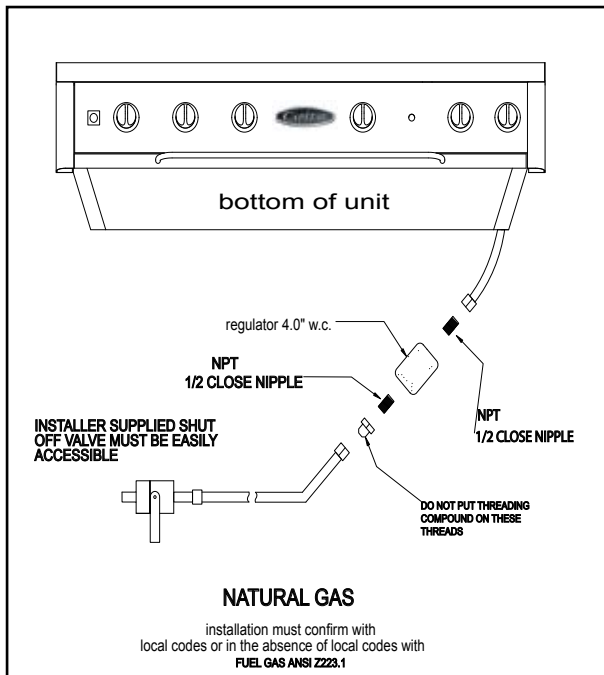

Fig 1

Verify the type of gas to be used, either LP (propane), or Natural gas, and make sure the marking on the appliance rating plate agrees with that of the supply.

NEVER connect an unregulated gas line to the appliance!

An installer supplied gas shut-off valve must be installed in an easily accessible location. All installer-supplied parts must conform to local codes, or in the absence of local codes, with the National Electrical Code, ANSI/NFPA 70-1990, and the National Fuel Gas Code, ANSI Z223.1-1988.

All pipe sealants must be an approved type. All gas connections should be made by a qualified technician and in accordance with local codes and ordinances. In the absence of local codes, the installation must comply with the National Fuel Gas Code ANSI Z223.1-1988. Gas conversion kits are available from the factory. When ordering gas conversion kits, please have the model # and gas type (natural or LP) available from your grill.

The appliance and its individual shut-off valve must be disconnected from the gas supply piping system during any pressure testing of that system at test pressures in excess of 1/2 PSIG (3.5 kPa). The appliance must be isolated from the gas supply piping system by closing its individual manual shut-off valve during any pressure testing of the gas supply piping system at test pressures equal to or less than 1/2 PSIG (3.5 kPa). The installation of this appliance must conform with local codes or, in the absence of local codes, with the National Fuel Gas Code, ANSI Z223.1-1988. Installation in Canada must be in accordance with the standard Can 1-b149.1 and/or .2 (installation code for gas burning appliances and equipment) and local codes.

NATURAL GAS HOOKUP:

- Connection: 1/2" NPT male. Operating Pressure: 4.0" W.C.
- Supply Pressure: 5" to 14" water column. If in excess of 14" W.C. a step down regulator is required. Check with your local gas utility company or with local codes for instructions on installing gas supply lines. Be sure to check on type and size or run, and how deep to bury the line. If the gas line is too small, the grill will not function properly. Any joint sealant used must be an approved type and be resistive to the actions of LP gases.

AWESOME

total gas consumption: **POWER!**

- PSQ30ZRBI = 65,000 btus
- PSQ30RBI = 65,000 btus
- PSQ40RBI = 90,000 btus
- PSQ40RC = 90,000 btus
- PSQ52RSBI = 120,000 btus
- PSQ52RCSB = 120,000 btus
- PSQ52RBI = 130,000 btus
- PSQ52RC = 130,000

TO HOOK-UP THE FITTINGS SUPPLIED WITH THE GRILL:

Assemble as shown (Fig.1). Use threading compound on male threads only. Do not use threading compound on the male end of the 1/2 NPT. Use second pipe wrench to hold the grill inlet pipe to avoid shifting any internal gas lines of the grill. Ensure that the regulator arrow points in the direction of gas flow towards the unit, away from the supply. **Do not forget to place the installer supplied gas valve in an accessible location.**

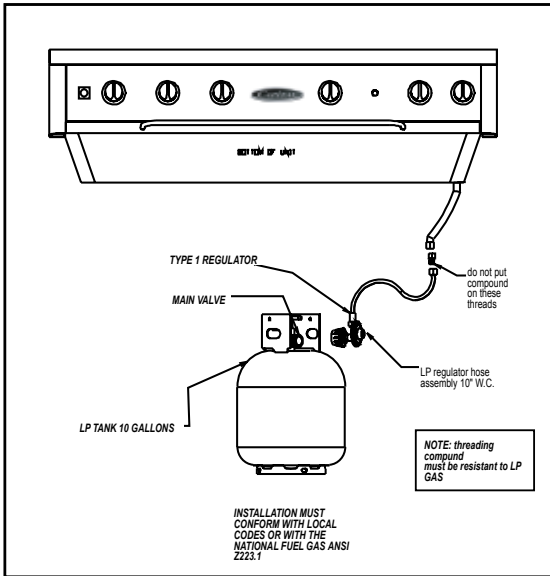

Fig 2

■ LP GAS HOOK UP (TYPE 1 OR QCC1 REGULATOR)

Grills and side burners orificed for use with LP gas come equipped with a high capacity hose/regulator assembly for connection to a standard 20lb. LP cylinder (Type 1). **The LP tank is not included.**

Connection: 1/2" NPT male with a 3/8" Flare adapter (included). LP hose with a quick disconnect and fittings are included. Operating Pressure: 10.0" W.C.

To connect the LP regulator/hose assembly to the tank/valve assembly, first make sure the main valve on the tank is completely closed. Although the flow of gas is stopped when the Type 1 system is disconnected as part of its safety feature, you should always turn off the LP tank main valve after each use and during transport of the tank or unit (see Fig. 2). Insert the regulator inlet into the tank valve and turn the black coupler clockwise until the coupler tightens up. Do not over-tighten the coupler. Turn the main tank valve "ON" and turn the burner control valves on the unit to the "HI" position for about 20 seconds to allow the air in the system to purge before attempting to light the burners.

■ LP TANK REQUIREMENTS:

A dented or rusty LP tank may be hazardous and should be checked by your LP supplier. Never use a cylinder with a damaged valve. Always check for leaks after every LP tank change. The LP gas cylinder must be constructed and marked in accordance with the specifications for LP gas cylinders of the U.S. Department of Transportation (DOT) and designed for use with a Type 1 system only. Do not change the regulator/hose assembly from that supplied with the unit or attempt to use a Type 1 equipped regulator/hose assembly with a standard 510 POL tank/valve assembly. The cylinder must be provided with a shut off valve terminating in an LP gas supply cylinder valve outlet specified, as applicable, for connection Type 1. If the appliance is stored indoors, the cylinder must be disconnected and removed from the appliance. Cylinders must be stored outdoors in a well-ventilated area out of the reach of children.

NOTE:

When an LP unit is directly attached into an LP house system, the step down regulator MUST be used to reduce the supply pressure to a max. 14" W.C. and min. 11" W.C. to the grill regulator.

leak testing — 7

GENERAL:

Although all gas connections on the grill are leak tested at the factory prior to shipment, a complete gas tightness check must be performed at the installation site due to possible mishandling in shipment, or excessive pressure unknowingly being applied to the unit. Periodically check the whole system for leaks, or immediately check if the smell of gas is detected.

BEFORE TESTING:

Do not smoke while leak testing. Extinguish all open flames. Never leak test with an open flame. Make a soap solution of one part liquid detergent and one part water. You will need a spray bottle, brush, or rag to apply the solution to the fittings. For LP units, check with a full cylinder. The valve panel must be removed to check the valves and fittings. First, remove the knobs. Next, remove the drip pan tray to access the screws that affix the front panel to the unit. Using a screwdriver, remove the screws. Lastly, gently pull the panel downward and out, making sure that you are not pull out the wires to the ignition system and lights. Unplug the wires from the ignition module and the back of the ignition button. Remove the screws which hold the service panel in place.

TO TEST:

Make sure that all control valves are in the "OFF" position. Turn the gas supply "ON". Check all connections from the supply line, or LP cylinder up to and including the manifold. Soap bubbles will appear where a leak is present. If a leak is present, immediately turn off gas supply, tighten any leaking connections, turn gas on, and recheck. Check all the gas connections at the base of the control valves where they screw into the manifold pipe

To check rotis burner and safety valve, the burner must be lit, then leak test the connections located behind the service panel. If you cannot stop a gas leak, turn off the gas supply and call your local gas company, or the dealer from whom you purchased the grill. Only those parts recommended by the manufacturer should be used on the Grill. Substitution can void the warranty.

Do not use the grill until all connections have been checked and do not leak.

Check all gas supply fittings for leaks before each use. It is handy to keep a spray bottle of soapy water near the shut-off valve of the gas supply valve. Spray all the fittings. Bubbles indicate leaks. (See Fig. 3 and 4)

Fig 3

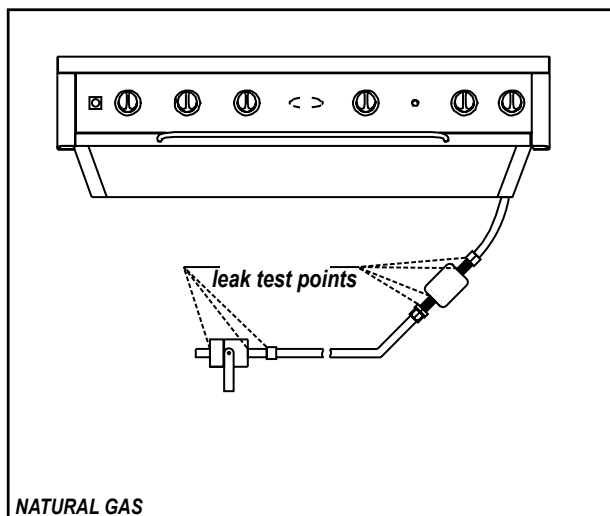
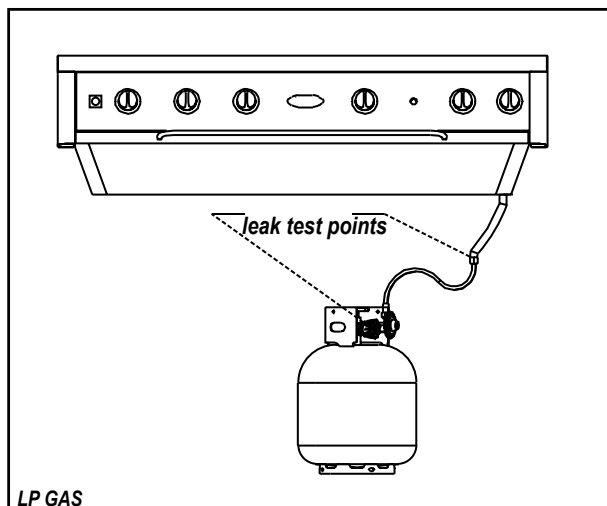

Fig 4

GENERAL:

The grill is designed for easy placement into non-combustible masonry enclosures. For non-combustible applications the grill drops into the opening shown in **Fig 5** and hangs from its side flanges. A deck is not required to support it from the bottom.

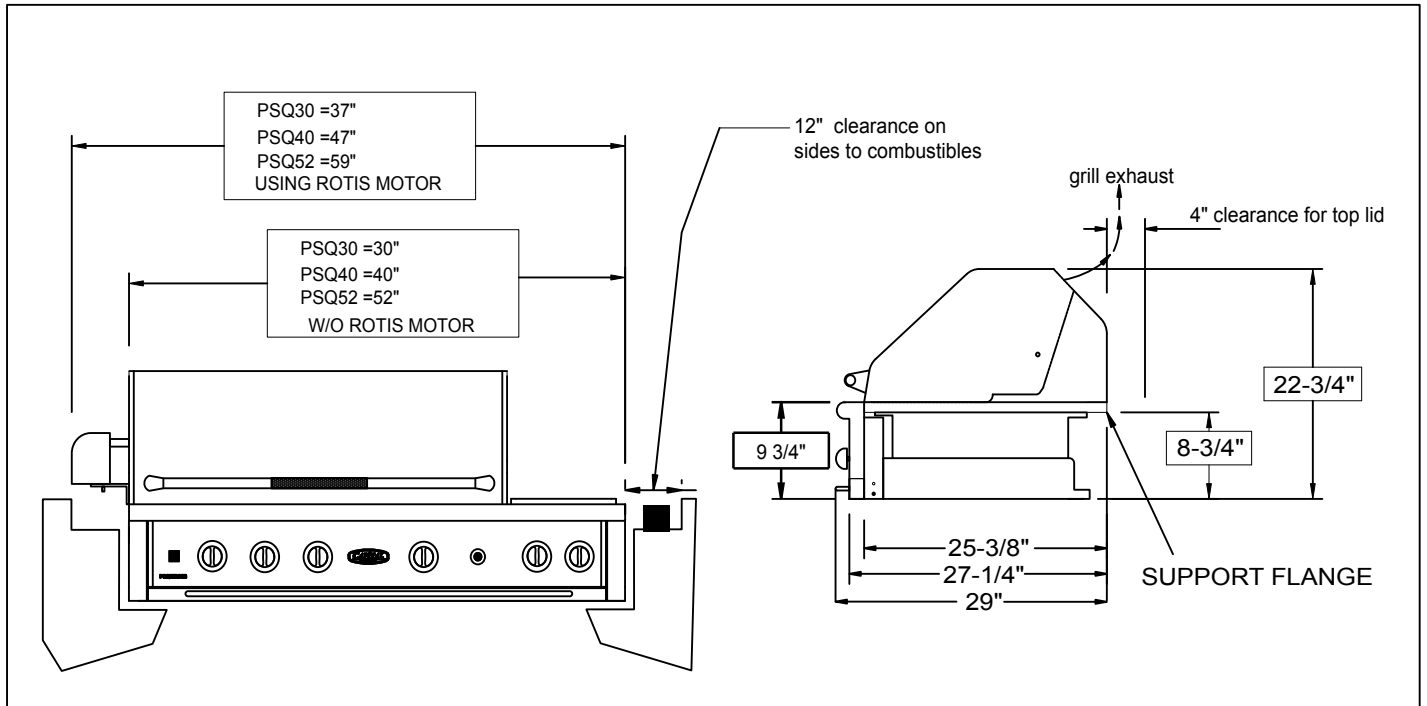

Fig 5

LOCATION:

When determining a suitable location, take into account concerns such as exposure to wind, proximity to traffic paths, and keeping any gas or electrical supply lines as short as possible. Locate the grill only in a well-ventilated area. Never locate the grill in a building, garage, breezeway, shed or other such enclosed areas without an approved ventilation system. During heavy use, the grill will produce a lot of smoke. Ensure there is adequate area for it to dissipate.

IMPORTANT:

A minimum of 12" clearance from the sides and a minimum of 6" from the back must be maintained from the grill above and below the cooking surface to adjacent vertical combustible construction. See **Fig 6** on next page.

NOTE: For combustible enclosures grills MUST be installed with an insulated jacket! Use of insulated jacket requires alternate cutout dimensions.

PRIMARY VOLTAGE

Black cord must be connected to a 120 volt outlet.

SECONDARY VOLTAGE

White wires must be connected to the two gray wires descending from the back of the unit.

NOTE:

A factory-authorized, qualified professional technician/electrician MUST make all electrical connections!

DETAIL "A"
PSQ52RBI

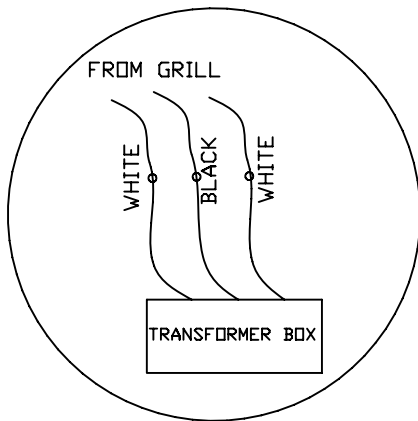

DETAIL "A"
PSQ52 W/SB
PSQ40 & PSQ30

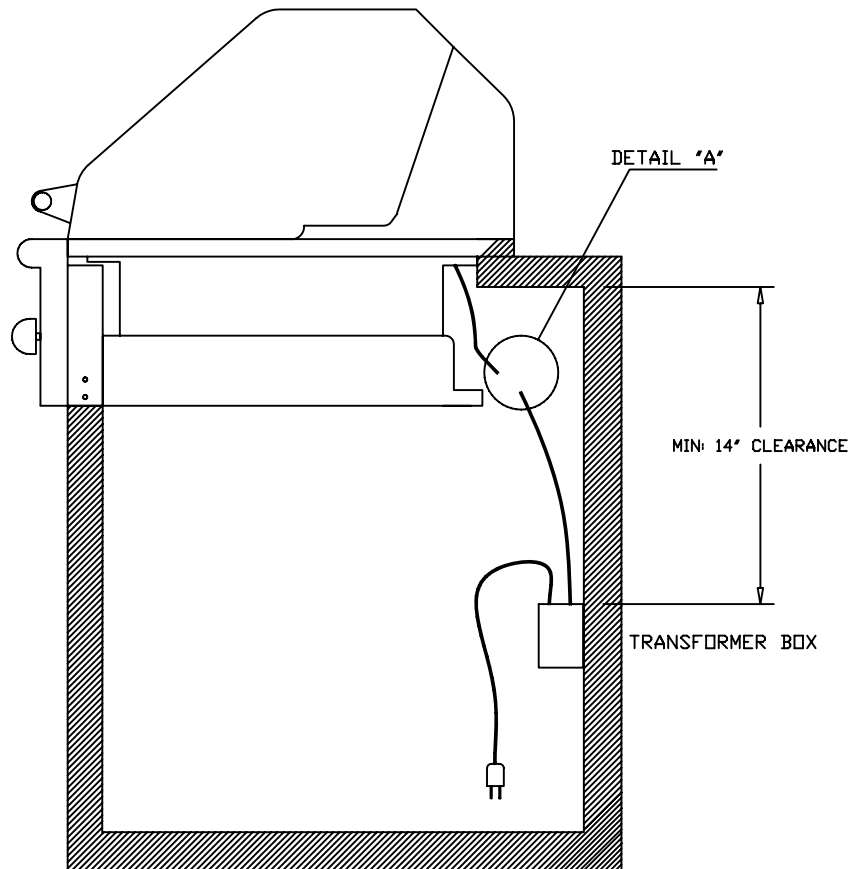
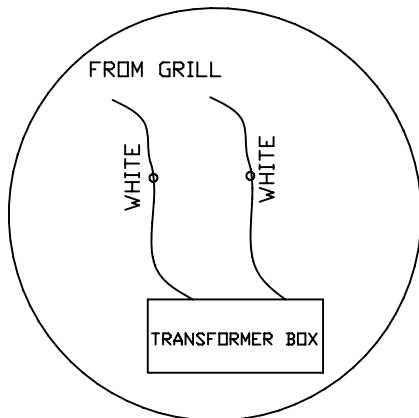

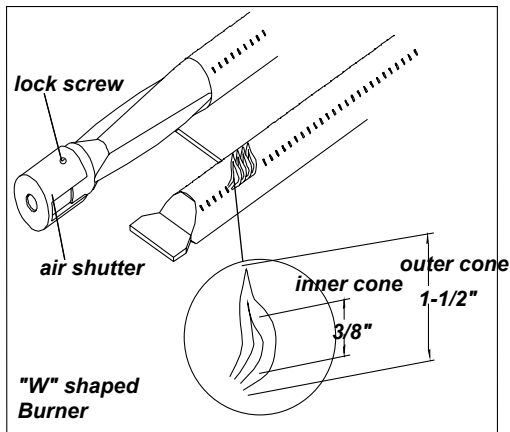

Fig. 7

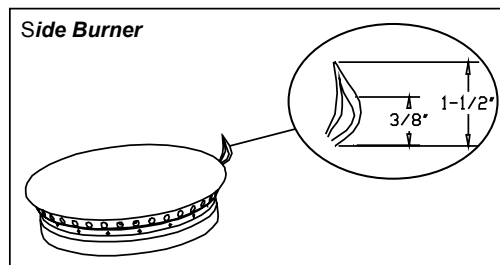

Fig. 8

Air Shutter Adjustments:

We test and adjust every burner at the factory for proper flame height prior to shipping. However, variations in the local gas supply, or a conversion from one gas type to another may make it necessary to adjust the burners. The flames of the burners, except rotisserie and infrared-zone burners, should be visually checked and compared to Fig. 7.

Flames should be BLUE and stable, with no yellow tips, excessive noise or lifting. If ANY of these conditions exist, check to see if the air shutter is blocked, or burner ports are clogged by dirt, debris, spider webs, etc. Once the burner has been properly cleaned, proceed with the air shutter adjustment.

IMPORTANT:

The amount of air that enters a burner is governed by a sheet metal cup at the inlet of the burner called an Air Shutter. It is locked in place by lock-screw which must be loosened prior to making the air-shutter burner adjustment.

do this!

To access the grill burner and to make the proper air-shutter adjustment for proper air/gas mixture do the following:

1. Remove the grill racks and radiant trays.
2. Lift the burner out as described in the section BURNER CLEANING.
3. With a screw driver, loosen the lock-screw on the face of the air shutter.
 - For LP Units: set air shutter approximately at 3/8 inches
 - For NG units, set air shutter to approximately 1/8 inches

Access for the side burner air shutters is through the top after removing the top burner grate and aeration pan assembly (Fig. 8)

Low Setting Adjustments:

The grill valves feature an adjustable low setting. Due to fluctuations in gas pressure, heating value or gas conversion, you may feel it necessary to increase or decrease gas flow in the low position. We do not recommend adjusting the infrared rotisserie burner, nor the Infrared-Zone burner.



Fig. 9

do this!

To Adjust:

(Tools Required: Pliers, narrow flat tipped screwdriver)

1. Light the burner.
2. Turn the control knob to the lowest setting (all the way counter clockwise).
3. Remove the knob.
4. While holding the valve shaft with pliers, insert a thin flat tipped screwdriver into the shaft and while viewing the burner adjust to a minimum stable flame. (**Fig. 9**)

IMPORTANT!

Before lighting, inspect the gas supply piping or hose prior to turning the gas "ON".

If there is evidence of cuts, wear, or abrasion, replace it prior to use.

drawing showing burner, valve and orifice position

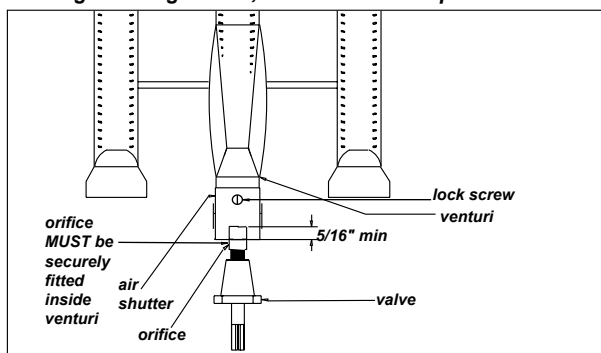

Fig. 10

■ "W" SHAPED PERFORMANCE BURNERS:

Capital's Performance Series™ grills possess EXCLUSIVE features not found anywhere else. Our "W" Shaped Performance Burners are constructed of non-rusting stainless steel for maximum life and rated at 25,000 BTUs each for the perfect balance of power and efficiency.

■ EXCLUSIVE INFRARED-ZONE™:

Our EXCLUSIVE Infrared-Zone™ grill burner is rated at 25,000 BTUs and is the perfect tool for creating those seared restaurant quality steaks. But moreover, whereas other "sear-zone" burners ONLY operate on HI, our exclusive Infrared-Zone allows you to cook on Med and LO settings, for added versatility and performance.

■ ROTISSERIE SYSTEM:

The infrared rotisserie burners are rated at 15,000 BTU's each and deliver astounding heat in a concentrated area. Our EXCLUSIVE cast stainless steel rotiss. forks secure the meat in place and the heavy duty motor can effortlessly rotate up to 50 lbs of meat. **We always recommend you use oven mitts when handling the spit rod, as the metal will heat up considerably during cooking.**

■ "HIT THE LIGHTS":

Capital's Performance Series™ lighting system features 20 Watt halogen lights and illuminates the entire grill surface easily with the push of a button. The lens covers are easy to remove and can be safely placed in the dishwasher.

Note: Due to space limitations, all features are NOT listed here. Seriously, we could write endlessly about our superior construction, lids, features, efficiency, power, etc. etc. So, it's best to see your local dealer for details! Thanks...

■ Stainless Steel Tru-Side™ Grates:

Our EXCLUSIVE Tru-Side™ grates are two position, double sided grease channeling grates which allow excellent grease management capabilities. They guard against excessive flare-ups, while managing the grease efficiently and safely. Grease pools in the channels and is directed away from the radiant trays, thus minimizing flare-ups! The racks are constructed of thick stainless steel and are guaranteed against rust for LIFE! Use the channel side up for meats of a higher fat content, and the channel side down for fish and vegetables.

Note: stainless steel grill racks will discolor considerably after first use. This won't affect their performance in any way.

■ PERFORMANCE CARTS:

The Performance Series™ carts feature several EXCLUSIVE features. Hidden wheels with locking casters, perfectly balanced drawer systems, hand welded and corners and edges, space for the optional Cutting Board, and a heavy duty construction made from the finest stainless steel available from select mills from around the world.

■ ZONE-COOKING SYSTEM™

Our EXCLUSIVE Zone-Cooking System™ utilizes stainless steel baffles to separate each burner into "zones" or compartments. Heat is trapped in usable zones so you can cook a variety of types of food, for a variety of purposes, with a multitude of temperature settings. Set the Infrared-Zone section on HI for searing steaks, one section on LO for delicate vegetables, and another section on MED for bratwurst links or ahi tuna! The Performance Series™ grills give you more freedom and flexibility than any other BBQ product available.

Hi There!

*if you have any questions regarding using a feature, or if you have created some marvelous results using our Performance Series™ grills, we'd love to hear from you: 1-866-402-4600
customerservice@capital-cooking.com*

A. BEFORE YOU START, CHECK CONNECTIONS:

Before lighting the grill, check that the pressure regulator and hose assembly supplied with the unit is installed. The replacement pressure regulators and hose assembly must be the type specified by us, the manufacturer, and the installer **MUST** have performed all leak tests, burner adjustments, air shutter adjustments, electrical connections and **MUST** leave the checklist with you before you attempt to light the grill.

Do not use the grill if the odor of gas is present at ANY TIME. Make sure all knobs are in the OFF position. If the unit is LP and you smell gas, make sure that gas pressure regulator is correctly installed into the tank and leak check the hose and regulator connections with a soap and water solution before operating the grill. If you are confident that no leak is detected, turn on the gas supply. If you are at all unsure, please contact your installer and have him check the connections for leaks.

If you are certain that no leaks are detected and there is no odor of gas, and you are certain that all knobs are in the OFF position, and grill does not light, please check that there is gas in the tank. Sometimes it's easy to overlook this small detail. If there is gas and the grill is not lighting, call your installer to check the connections. And please, always keep your face and body as far away as possible from the grill when lighting.

WARNING!

- **DO NOT leave the grill unattended while cooking.**
- **KEEP a spray bottle of soapy water near the gas supply valve and check the connections before each use.**
- **DO NOT attempt to "Light" the grill if odor of gas is detected.**
- **WAIT five minutes before relighting a hot grill.**

B. LIGHTING THE "W" GRILL BURNERS:

Open the grill lid. Make sure all knobs are in the OFF position. Turn the main gas supply on. If you smell gas, shut-off gas-supply and contact your installer. If you do not smell gas and you are **POSITIVE** that all connections are properly sealed and free of leaks, turn the left main burner to the LITE position. You will hear the flow of gas through the manifold. Immediately push and hold the ignition button, turn the selected burner knob to HI. If the burner does not light within 4 to 5 seconds, turn knob OFF and wait 5 minutes before trying again for any accumulated gas to dissipate.

IMPORTANT!

YOUR SAFETY IS THE MOST IMPORTANT CONSIDERATION TO GIVE WHEN LIGHTING A GRILL. Keep children and pets away from grill while lighting. Keep hands and face away from the interior of the grill when lighting!

C. MATCH LIGHTING BURNERS:

If the burner will not light after several attempts, then the burner can be match lit. If you've just attempted to light the burner with the ignition, allow 5 minutes for any accumulated gas to dissipate. Keep your face as far away from the grill as possible and hold and pass a lit, **long stem** match over the hole located on the top left for burner on the left, or the top right hole for the right burner. Push and turn the control knob, which is centered on the burner where the lit match is located, to HI. If the burner does not light in 4 seconds turn the knob off, wait 5 minutes and try again (**Fig. 11**).



Fig. 11

D. CROSS LIGHTING METHOD:

Once the left or right burner is lit, the adjacent burner(s) can be lit by the cross lighting method. Remember, BE SAFE! So, turn all knobs to OFF. Remove grill racks, then remove radiant trays. Remove the stainless steel separator plates that comprise our zone-cooking (TM) system. Now, for center burners to cross light, light adjacent far left or right burner using the standard or match light procedure. Push and turn the control knob for the desired center burner to HI. The gas will be ignited by the adjacent burner's flame. If the burner does not light in 4 seconds, turn knob off, wait 5 minutes and try again. **Note: Infrared grill burner cannot be cross-lit.**

E. USING THE GRILL:

Grilling requires HIGH heat for searing and proper browning. Most foods are cooked at the MEDIUM heat setting for the entire cooking time. However, when grilling large pieces of meat or poultry, it may be necessary to turn the heat to a lower setting after the initial browning. This cooks the food through without burning the outside. Foods cooked for a long time or basted with a sugary marinade may need a lower setting near the end of the cooking time.

- Check that the drip pan and grease trays are in place.
- With the grill lid open, turn the control knob to HI to light. Preheat the grill for 5 to 10 minutes.
- Place food on the grill racks and cook to the desired doneness. Adjust heat setting, if necessary.
- The control knob may be set to any position between HI and LO Note that most BBQ'ing is between MED and LOW, most grilling is done on HI.
- Allow the grill to cool, then clean the grates, drip pan and grease tray after each use.

Note: If using LP gas, your preheat time may be significantly shorter than recommended above. To prevent overcooking or burning, you may want to lower heat settings.

■ **FLAME HEIGHT:**

The correct height of the flame depends on the size of and material of the utensil being used, the food being cooked and how much liquid is in the utensil. Here are some basic rules for selecting the flame height.

- Flame should never extend beyond the bottom of the pan.
- Utensils that conduct heat slowly (such as glass-ceramic) should be used with a low or medium flame, unless you are cooking with a large amount of liquid.

- TO LIGHT DUAL SIDE BURNERS:
(PSQSB2000, 52RCSB and 52RSBI
Models Only):

CAUTION: The side burner cover may be hot if the grill burners are in operation. Remove before use.

- First remove the SS burner cover and any cooking utensils from the burner grate. Push and hold the ignition button, turn the control knob to the "HI" position until the burner is lit or 4 seconds pass. If the burner doesn't ignite, wait 5 minutes for any accumulated gas to dissipate then try again. If the burner will not light after several attempts, wait 5 minutes and then the burner can be match lit by holding a lit match next to the burner ports and turning the correct valve to "HI."
- Your grill is equipped with the same sealed burners we use on our indoor residential ranges. Each is rated at 15,000 BTU/HR and has a battery ignition for efficient lighting. The burner grates are porcelain enamel over cast iron for maximum durability. To cover the power burners when not in use the side burner cover. This cover protects the side burners from dust and debris and also acts as a work surface. When using the grill burners with the side burner cover in place and the side burner off, be careful as heat can conduct from the grill section and cause the cover to heat up.

WARNING!
NEVER attempt to light the power burners with the accessory stainless steel cover in place.

REMINDER #1:

Check that the batteries in your ignition system are fresh and new! The grill comes with a test battery, but depending on a variety of factors, the battery's life may have worn out before it gets to our customers' homes. So, please install NEW batteries. Please note, batteries are NOT covered under warranty.

NOTE:

The location of the rotisserie burner makes it more susceptible to strong wind conditions, more so than the protected grill burners. For this reason you should avoid operating the rotisserie during windy conditions. As an added safety feature we've equipped the burner with an automatic safety valve that will not allow gas to flow to the rotisserie burner unless the following conditions are present with the knob on:

1. The safety valve button is pressed and held down.
2. The safety valve thermocouple has been sufficiently heated to keep safety valve open.

WARNING:

Keep hands and face away from front of burner! STAND TO THE SIDE WHEN LIGHTING. ONCE LIT MOVE HAND AWAY QUICKLY!

■ LIGHTING THE ROTISSERIE BURNER:

The safety valve on all Performance Series™ rotisserie sections is included in the main burner valve. No separate safety button is necessary to operate the rotisserie safety feature.

Open the lid. Push and turn the control valve to "HI", keeping knob pushed in and wait 5 seconds. Push igniter button and hold until rotisserie burner lights. You'll hear a "ticking" sound. Once lit keep knob pushed and held in position for 5 seconds and DO NOT release the control knob once burner is lit. After 5 seconds set the knob to desired setting. If the burner does not light within 4 to 5 seconds, release the safety valve button and turn the control knob to "OFF" Wait at least 5 minutes before trying again.

- If relighting a hot burner, wait 5 minutes.
- Never leave the control knob ON if rotisserie is not in use.
- Never light a grill burner under the rotisserie while rotisserie burner is lit.

■ MANUAL LIGHTING:

To manually light the rotisserie, place a butane lighter near the tip of the thermocouple. Turn the control knob to "HI." Hold the safety valve button in for about 4 to 5 seconds or until the burner remains lit. Once lit, turn control knob to desired setting. If the burner does not light within 4 or 5 seconds, release the safety valve button and turn the control knob to "OFF" and wait 5 minutes before trying again.

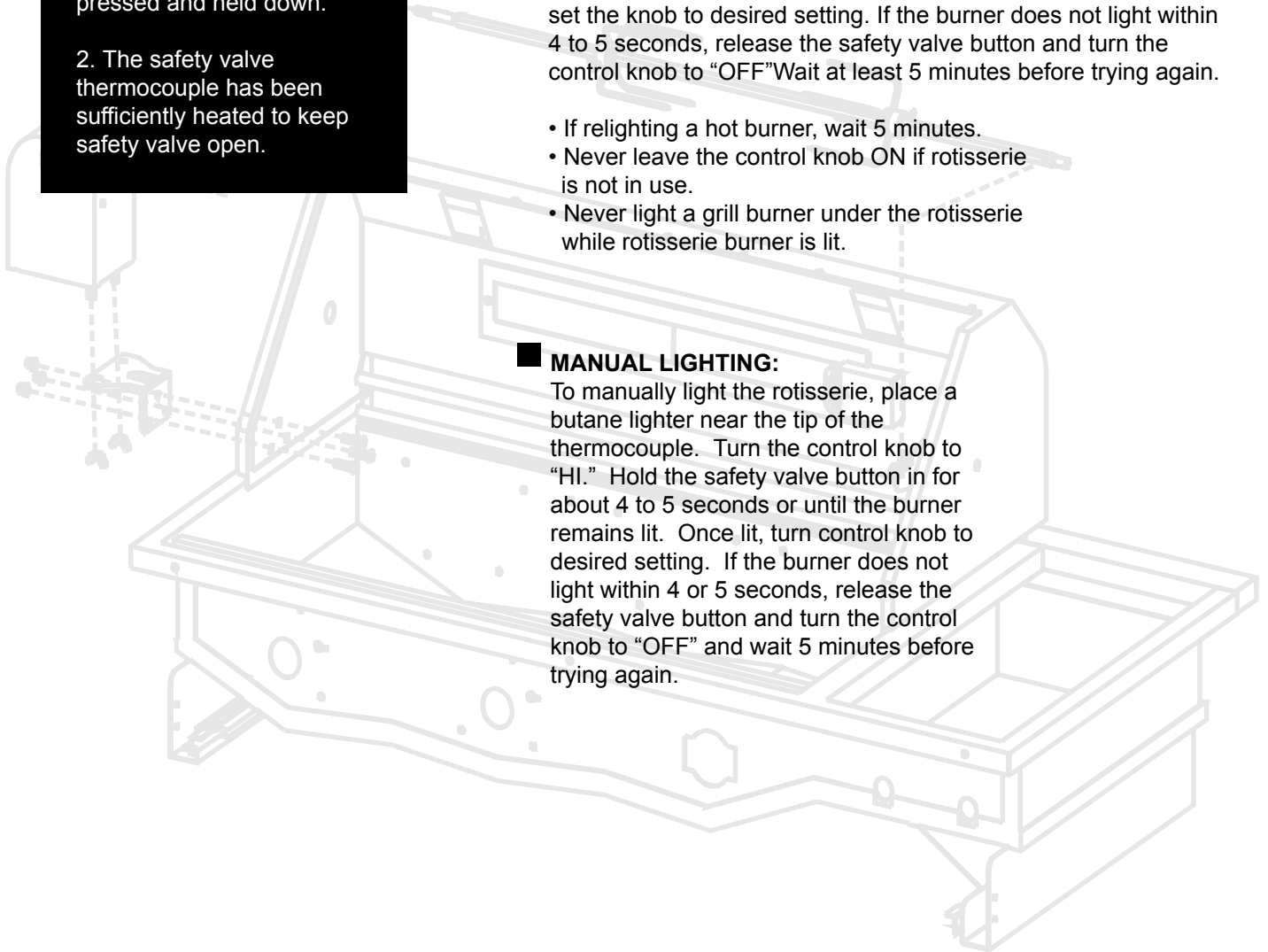



Fig. 12

NOTE:

The grill rotisserie system is designed to cook items from the rear using intense infrared heat. The rotisserie burner is an infrared type that provides intense, searing radiant heat. Preferred by chefs over other methods, this intense heat is magnificent for searing in the natural juices and nutrients found in quality cuts of meat.

The location of the burner allows the placement of the rotisserie basting pan (included) beneath the food to collect juices and drippings for basting (see Fig. 12).

Once lit, the rotisserie burner will reach cooking temperatures in about 1 minute. The orange/red glow will even out in about 5 minutes. The rotisserie motor is equipped with metal gears and is capable of turning up to a 50 lb cut of meat or poultry.

The rotisserie motor on the grills is secured down to a heavy-duty bracket with two wing nuts and screws. The bracket in turn is affixed to the left side panel. The rod for the rotisserie is assembled into the motor assembly by placing the pointed end into the motor, and resting the handle end on the support at the left side of the grill. With the rod pushed as far as possible into the motor, the grooved rod will rest on the rollers.

helpful hint

To flavor the contents of the basting pan, you can add herbs, onion, garlic, or spices. Hams are especially good with the addition of pineapple slices and brown sugar to the basting pan.

WARNING!

Electrical Grounding Instructions:

This appliance (rotisserie motor) is equipped with a three-prong (grounding) plug for your protection against shock hazard and should be plugged directly into a properly grounded three-prong receptacle. Do not cut or remove the grounding prong from this plug.

The rotisserie must be electrically grounded in accordance with local codes or, in the absence of local codes, with the National Electrical Code, ANSI/NFPA 70-1990. Keep the rotisserie motor electric cord away from the heated surfaces of the grill. When not in use, remove and store the motor in a dry location.

WARNING!

Never turn the grill burners (bottom burners) ON during rotisserie cooking. It will burn your meat and make it extremely dry. Use only one thing at a time, either grill or rotisserie.

try this!

PREPARATION:

Recommended:

Butcher string, scissors, broiler pan (bottom only), pliers, instant read thermometer, foil, and hot pads.

Working Area:

Allow enough space to accommodate food and rotisserie rod assembly in a clean environment.

Meat Preparation:

Tie meat with butcher string or unwaxed dental floss in three areas. Buy a roast that is equally balanced from top to bottom in size. The meat will cook more evenly while on the rotisserie. For poultry, tie wings and legs to the body using dental floss or butcher string to prevent flopping around.

- Determine the center placement for the food, put 1st prong on Rod, turn "L" shape screw to tighten.
- Center tied meat/poultry on rod and place second prong. Turn "L" shaped screw to tighten.
- Pick up rod, rotate it to check for balance. If not balanced, adjust prongs and food to balance it. Take pliers and tighten the "L" shaped screw on both sides of the prong.
- Remove grates and top rack on the grill, place bottom portion of broiler pan on radiant trays, so meat drippings can be caught in pan.



Correct placement of rotisserie basting pan in grill. Remove grill racks and position pan atop the radiant trays.

Fig. 13

try this!

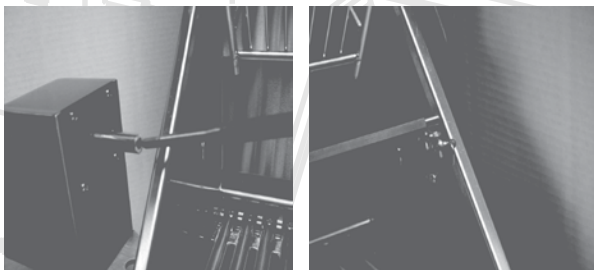

Fig. 14

Fig. 15

COOKING ON THE ROTISSERIE:

1. Place prepared rod into motor (Fig. 14).
2. Lay across to other side in groove/ball bearings as shown (Fig 15).
3. To check temperature, turn off motor, turn temperature to low while using your instant read thermometer (sold separately). For poultry it should read 170 degrees in breast. Thermometer should touch the breastbone, then lift up 3/4" from the bone to get a more accurate temperature. Turn the motor ON, return to HI if more cooking is needed. Repeat above instructions.
4. Cover with foil for a 15 to 20 minute waiting time. Meat will carve better and juices will go back into the meat.

CAUTION!

The fork rods are very sharp. Keep hands away from tips when loading and removing the food.

1. PSQ-SBX = smoker box

A. Remove all protective plastic from the smoker box. Wash thoroughly before use to remove any manufacturing oils, cleaners, etc. that may accumulate.

B. Lift the smoker box lid and add just enough water so that it lines the bottom of the internal tray.

C. Load a generous amount of flavored or unflavored smoker chips in tray. Please note that sometimes, less is more.

D. Place smoker tray in any desired position on grill. For best results place directly above main grill burner.

E. Light burner beneath smoker tray.

WARNING!

ALWAYS use oven mittens when handling a hot/warm smoker box.

2. PSQ-GPX = griddle plate

The drop in griddle plate is constructed of 3/8" thick stainless steel. It is normal for it to darken with use as oils cook onto the surface. The griddle is made from 304 stainless steel and with proper care it should not rust.

Before using the griddle to cook, preheat it for about 10-15 minutes. To make delicate foods easier to turn, spray a light mist of non-stick vegetable oil directly onto the surface of the griddle before pre-heating.

We recommend that you clean the griddle while it is still hot. This can easily be done by first scraping it with a spatula. Allow it to cool, then wipe the entire surface with heavy cloth. Applying a thin layer of vegetable oil will ensure that it retains its shine.

WARNING!

Use caution when cleaning a hot griddle.

3. PSQ-CHBX = chopping block (birch)

WARNING!

Moisture may expand the chopping board so that it becomes warped and unable to fit comfortably in the side tray shelves.

NEVER leave a chopping board out overnight or in the presence of excessive moisture or humidity. ALWAYS store the chopping blocks in a cool dry place after each use.

just say "Hi"

Remember, we really do pay close attention to what our customers say. After all YOU are our marketing department. So, if you have a suggestion for us, or would like to see us improve something, or you'd like to see a feature built into our grills that isn't there, or if you simply want to compliment us on a fine job, please send us an email to:

marketing@capital-cooking.com
1 - 8 6 6 - 4 0 2 - 4 6 0 0

■ ABOUT MEAT:

The doneness of meat, whether rare, medium, or well done, is affected to a large degree by the thickness of the cut. Expert chefs state, that it is virtually impossible to have a rare doneness with a thin cut of meat. The cooking time is affected by the kind of meat, the size and shape of the cut, the temperature of the meat when cooking begins, and the degree of doneness desired. When defrosting meats, it is recommended that it be done overnight in the refrigerator as opposed to a microwave. This in general yields a juicier cut of meat. Use a spatula instead of tongs, or a fork to turn the meat. A spatula will not puncture the meat and let the juices run out. To get the juiciest meats, add seasoning or salt after the cooking is finished, and turn the meat only once (juices are lost when the meat is turned several times). Turn the meat just after the juices begin to bubble to the surface. Trim any excess fat from the meat before cooking. To prevent steaks or chops from curling during cooking, slit the fat around the edges at 2-inch intervals.

■ ABOUT FLARE-UPS

Flare-ups are unavoidable and usually relate directly to the type of meat being cooked and its fat content. In fact, many professional chefs prefer flare-ups as they assist in locking in juices. The Performance Series™ grills utilize stainless steel wave shaped radiant plates that reduce flare ups considerably. Always trim excessive fat and use marinades sparingly.

■ ABOUT CLEANING THE INFRARED-ZONE™

To clean our exclusive Infrared-Zone™ burner, simply turn the burner on HI and leave ON for 20 to 30 minutes until all juices, fats, oils, marination sauces, etc. begin burning up. Turn OFF. Once the burner has sufficiently cooled, simply remove burner and brush off the ash. Use EXTREME CAUTION when handling a hot/warm burner. Always use gloves!

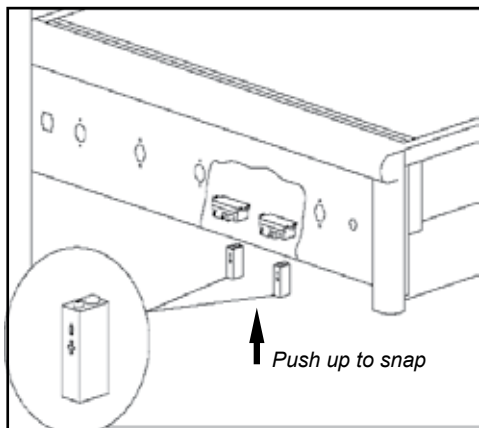

Fig. 16

■ **CARING FOR RADIANT TRAYS:**

Shake off excess debris and grease residue and put them in the dishwasher for easy cleaning.

WARNING!

Allow the grill to sufficiently cool before handling the radiant trays as these are designed to absorb heat and at maximum temperatures glow red hot!

■ **DRIP PAN AND SPILL TRAYS:**

The full width drip pan with grease trays will collect grease from the grill section, boil-overs, and spills from the power burners. The internal trays are dishwasher safe and we recommend that you first clean off the excess residue and debris before washing. Allow the pan and its contents to cool before attempting to clean. Clean grease from the pan often to avoid the possibility of a grease fire.

■ **REPLACING BATTERIES:**

Battery location is indicated on the front panel

1. Remove drip pan
2. Depending on your grill model, you will see 9 volt batteries ready for replacement
3. Pull battery out and replace
4. Push to snap (Polarity is shown in Fig 16)

Note:

Battery condition should be checked at least once a year.

■ **CARING FOR GRILL GRATES:**

(Recommended: Brass Bristle BBQ Brush, Mitts, Bowl of Tap Water.)

Please note, that heat discolors metal. After the first use, your grill grates will discolor. The easiest way to clean the grill grates is immediately after cooking is completed and after turning off the flame. Wear a BBQ mitt to protect your hand from the heat and steam. Dip a fine brass bristle BBQ brush in tap water and scrub the hot grill. Dip the brush frequently in the bowl of water. The steam created from the contact with the hot grill assists the cleaning process by softening any food particles. The food particles will fall onto the radiant tray and burn off or fall into the drip pan. If the grill is allowed to cool before cleaning, cleaning will be more difficult.

read this!

IMPORTANT!

Stainless steel may tend to rust in presence of chlorides and sulfides specifically in coastal area and/or areas of high humidity. To ensure rust prevention, wash all stainless steel surfaces every 2-4 weeks with fresh water and polish with stainless steel cleaner.

To prevent saline deposits and pitting on grill use a vinyl cover.

■ **STAINLESS STEEL CARE:**

The grill is constructed out of 304 stainless steel which is a non-magnetic stainless steel. After initial usage, areas of the grill may discolor from the intense heat given off by the burners: this condition is normal. There are many different stainless steel cleaners available on the market. Always use the mildest cleaning procedure first, scrubbing in the **direction of the grain**. To touch up noticeable scratches in the stainless steel, sand very lightly with dry 100 grit emery paper in the direction of the grain. Specks of grease can gather on the surfaces of the steel and bake on to the surface giving a “rust-like” appearance. For removal, use an abrasive pad in conjunction with a stainless steel cleaner. **Always rub in the direction of the grain.**

■ **REPLACING THE LIGHTS:**

1. Carefully wedge a flat tipped screwdriver between the back glass of the light cover and the rotisserie back panel as shown below.
2. Access the bulb and carefully pull out to remove.
3. Replace bulb with a new one.

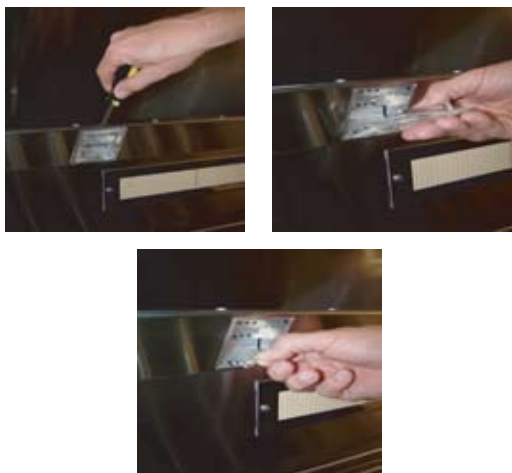

■ **CARING FOR YOUR GRILL BURNER:**

Remove the grill grates, then lift out the radiant trays. Grasp the burner and pull it up carefully and slightly towards the rear wall of the unit so the burner head comes off the brass orifice at the front. Angle the burner sideways and remove. (Fig. 17 and 18)

Clean the burner exterior with a wire brush. Clear stubborn scale with a metal scraper. Clear any clogged ports with a straightened paper clip. Never use a wooden toothpick as it may break off and clog the port. Shake out any debris through the air shutter. Use a flashlight to inspect the burner inlet to ensure it is not blocked. If obstructions can be seen, use a metal wire coat hanger that has been straightened out.

WARNING!
Make sure burner is cool before removing for cleaning.



Fig. 17



Fig. 18

■ **ORIFICE CLEANING:**

With the burner removed, remove the orifice and shine a flashlight through the opening to ensure there is no blockage. Use a needle to clear any debris. Be extremely careful not to enlarge the hole or break off the needle.

WARNING!

It is extremely important to center the burner on the orifice properly to prevent a fire hazard or explosion.

Be careful not to upset the air shutter's original position (unless readjusting). Lower the rear of the burner into the cut outs on the support channel at the rear of the burner box. Make sure it is level and does not rock. Light all the burners and check for proper flame characteristics. If adjustments are necessary, refer to section on Flame Adjustment in this guide. Do this prior to cooking on the grill

■ **SIDE BURNERS:**

The grill side burners (52" models only and PSQSB2000) are constructed of a porcelain coated cast iron top cap coupled with an aluminum burner containing ports and an aluminized base. The burners are sealed, which means that spills are contained in a sealed top section for easy cleanup. Frequency of cleaning will depend upon the climate and location, and how often you use the grill. If spill deposits, grease residue, and dust are allowed to collect over time, the presence of these materials can seriously jeopardize burner performance. It will be necessary to clean out the burner ports using a thin wire, needle or straightened paper clip.

■ **SIDE BURNER CLEANING**

Before cleaning, ensure the gas supply is turned off and the knobs are in the "OFF" position. Make sure the grill is cool. Remove the top grate. Lift and remove the burner caps and clean sealed pan with a mild soap and warm water cleaner. Clean burner base with a soap and warm water solution. Burner ports may be cleaned with a straightened paperclip. ***Do not use a toothpick to clean ports!***

a helpful reminder

Like all things of value, the more you protect and care for them, the longer they last, the better they perform, the more pleasure they give and the more value they hold. Your Performance Series™ grill is not just a great appliance, boasting some of the finest, most versatile features anywhere, but it is an investment. Please protect your investment by following these care guidelines and if you have a few care tips you wish to share with us, send us an email to :

m a r k e t i n g @ c a p i t a l - c o o k i n g . c o m
1 - 8 6 6 - 4 0 2 - 4 6 0 0

■ BEFORE CALLING FOR SERVICE:

If the grill does not function properly, use the following checklist before contacting your dealer for service. You may save the cost of a service call. Troubleshooting is for general purposes only. If the problem persists and you feel you require a service call, contact your dealer or the nearest authorized service agency to perform service. Only authorized service agencies can perform warranty service. Call a Capital Performance Series™ Specialist at 1-866-402-4600.

 Grill won't light when ignition button is pushed:

- 1) Remove the grill top grates and the radiant trays, watch the ignition tip. You should see a spark jump from the tip of the ignition when the ignition is pushed.
- 2) If there is no spark when ignition button is pushed, check the battery condition.
- 3) Attempt to match light the burners (see Section Titled Lighting the Grill) Check to see that other burners on the unit operate. Clean ignition tip of any debris.

 Burner flame is yellow or orange, in conjunction with the odor of gas:

- 1) Check the burner inlet for obstructions such as spider webs. Check the air shutter for proper adjustment.
- 2) Grill may be in a dusty area. Move to a less dusty area if possible.

 There's a "Low" heat even with the knob on "HI" position:

- 1) If only one of the burners appears low, clean the orifice and burner, clearing ports of any obstruction
- 2) Grill may be in a dusty area. Move to a less dusty area if possible.
- 3) Check for proper gas supply and pressure.
- 4) Pre-heat grill for a full 15 minutes.
- 5) If using LP gas, check for empty tank.

 Rotisserie won't light:

- 1) Check that there is a spark at the igniter.
- 2) Check that the rotisserie burner will light when attempting to match light.
- 3) Check if grill is being operated in an excessively windy area.

 Rotisserie lights, but will not hold flame once button is released:

- 1) Continue holding safety button in depressed position until burner remains lit when released.
- 2) Make sure thermocouple is touching ceramic burner.

 Lights do not work:

- 1) Check that the light switch on?
- 2) Is the unit connected to a power source and plugged in?
- 3) Is the circuit breaker tripped and needs to be reset?

■ **HOW TO OBTAIN SERVICE:**

For service, contact one of our **PERFORMANCE SERIES SPECIALISTS** at 1-866-402-4600.

Before you call, please have the following information ready:

- Model Number
- Serial Number
- Date of purchase and Installation
- A brief description of the problem
- Dealer name

Your satisfaction is of the utmost importance to us. If a problem cannot be resolved to your satisfaction, please write or fax us at:

Capital Cooking Equipment
Attn: Customer Service
13211 Florence Ave
Santa Fe Springs, CA
90670
USA

Fax us at 562-903-1167
Email us at customerservice@capital-cooking.com

FOR: _____

MODEL #: _____

SERIAL #: _____

GAS TYPE: _____

NOTES: _____

installer: initial beside each item

- specified clearances maintained
- nylon straps removed from burners
- all internal packaging removed
- knobs turn freely and all bezels are centered
- each burner lights individually or with adjacent burner lit
- air shutter adjustments made to all burners
- igniter clicks when pressed and spark is visible from igniter tip
- adjustable LO setting is satisfactory
- drip pan is in place and rolling freely
- pressure regulator is connected and set for 4.0" W.C. Nat. or 10" W.C. L.P.
- manual shut off valve installed and accessible
- unit tested and free of leaks
- side shelves are level (cart models only)
- cart drawers open and close freely (cart models only)
- lid sits on front ledge evenly
- user informed of gas Supply shut-off location
- radiant trays and grill racks securely in place
- lights functional
- rotisserie motor in place and plugged in
- rotisserie rod rotating freely when motor is turned ON
- side burner grates in place

INSTALLER: Please sign and date here and leave these instructions with customer:

X _____

date: _____

CUSTOMER: Ensure that installer completes checklist, explains each item before leaving. Please make sure the installer initials above and signs in the space provided.





THE POWER OF PERFORMANCE™

PERFORMANCE SERIES™ GRILLS

WARRANTY

- One (1) Year full parts and labor covers entire product.
- Two (2) Year comprehensive warranty covers the radiant system and infrared grill burner.
- Five (5) Year comprehensive warranty covering the porcelain coated cast iron range-top burners, infrared rotisserie burner and drip pans. Should structural deterioration occur to the degree of non-performance, a replacement will be furnished.
- Limited Lifetime Warranty against rust on all stainless steel components, including stainless steel grill burners and stainless steel grill racks (excludes normal heat discoloration).

WILL PAY FOR:

All repair labor found to be defective due to materials or workmanship for one full year "IN HOME" warranty during the first year of ownership. This does not apply if the unit was subjected to other than normal household use. Service must be performed by a Factory Authorized Service Agent during normal business hours. No charges will be made for repair or replacement at the location of initial installation or factory for parts returned pre-paid, through the dealer and claimed within the warranty period, and found by Capital to be defective.

Replacement will be FOB Capital, and Capital will not be liable for any transportation costs, labor costs, or export duties. This warranty shall not apply, nor can we assume responsibility for damage that might result from a failure to follow manufacturer's instructions or local codes, where the appliance has been tampered with or altered in any way or which, in our judgment, has been subjected to misuse, negligence, or accident. Implied warranty shall not extend beyond the duration of this written warranty. This warranty is in lieu of all warranties expressed or implied and all other obligations or liability in connection with the sale of this appliance.

WILL NOT PAY FOR:

- Installation or start up.
- Shipping damage.
- Service by an unauthorized agency.
- Damage or repairs due to service performed by an unauthorized service agency or the use of unauthorized parts.
- Service during other than normal business hours.
- Improper installation, such as improper hook-up.
- Service visits to teach consumers how to use the appliance, correct the installation, reset circuit breakers or replace home fuses.
- Repairs due to other than normal household use.
- Damage caused from accident, abuse, alteration, misuse, incorrect installation or installation not in accordance with local codes.
- Units installed in non-residential application such as day care centers, bed and breakfast centers, churches, nursing homes, restaurants, hotels, motels, schools, etc.
- Isolated geographic locations of 50 miles of travel distance or two hours of travel time both ways, for example, such places that require plane, train, boat or ferry trips, etc.

This warranty applies to appliances used in residential application only. It does not cover their use in commercial situations (commercial situations include but are not limited to restaurants, public parks and recreation areas, any area where units are exposed to multiple users, public cooking areas, etc.) This warranty is for products purchased and retained in the 50 States of the U.S.A, the District of Columbia and Canada. This warranty applies even if you should move during the warranty period. Should the original purchaser sell the appliance during the warranty period, the new owner continues to be protected until the expiration date of the original purchaser's warranty period. This warranty gives you the specific legal rights. You may also have other rights, which vary from State to State.

PSQ52RCSB WIRING DIAGRAM # 82012-01

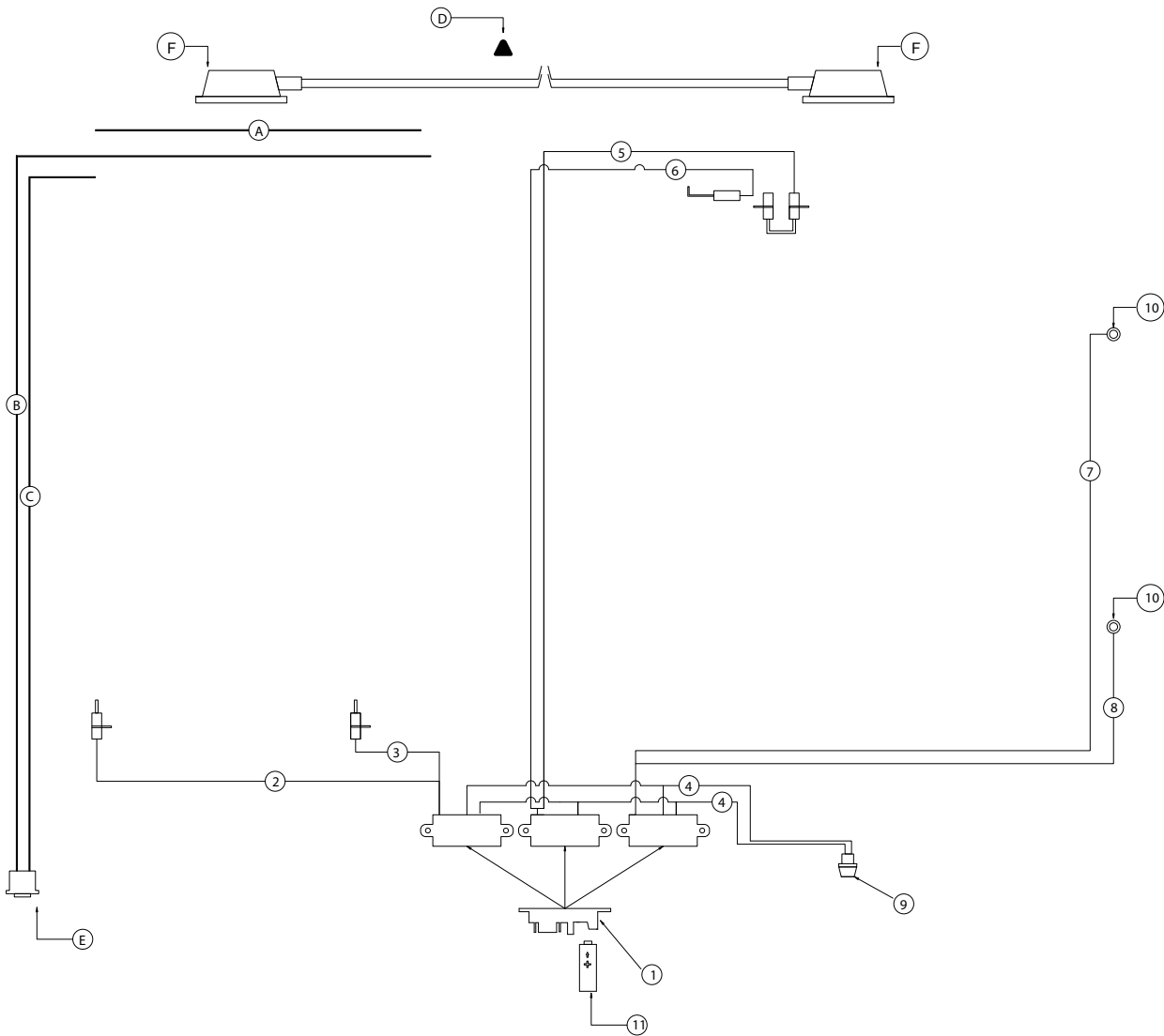

ITEM	PART NUMBER	DESCRIPTION
1	82417-01	H.E. ELECTRONIC IGN.
2	1517	L/H W BURNER ELECTRODE
3	1518	R/H W BURNER ELECTRODE
4	82013-01	SWITCH WIRE
5	1516-32	GRILL INFRA RED ELECT.
6	1515-46	ROTIS INFRA RED ELEC.
7	22	SIDE BURNER REAR WIRE
8	23	SIDE BURNER FRONT WIRE
9	82418	H.E. ELECTRONIC SWITCH
10	82315	SIDE BURNER ELECTODE
11	87040-01	9 VOLT VATTERY
A	82013-02	WIRE 36" FOR LIGHTS TO TRANSF.
B	82013-03	WIRE 52" FOR SWITCH TO LIGHTS
C	82013-04	WIRE 38" FOR SWITCH TO TRANSF.
D	83	CERAMIC WIRE NUT
E	82409	LIGHT WIRE NUT
F	82419	BBQ LIGHTS

1

1

PSQ52RC WIRING DIAGRAM # 82012-02

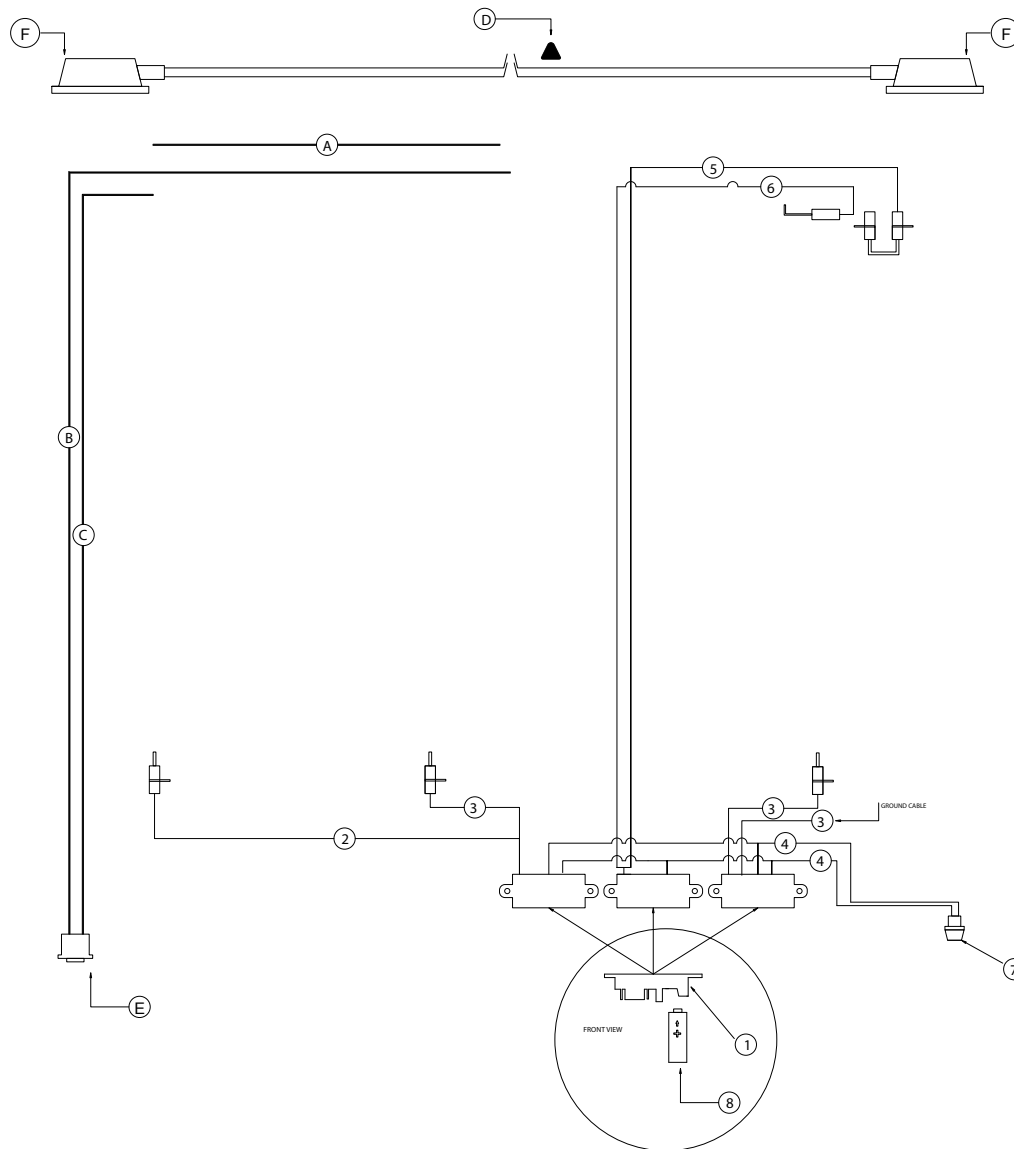

ITEM	PART NUMBER	DESCRIPTION
1	82417-01	H.E. ELECTRONIC IGN.
2	1517	L/H W BURNER ELECTRODE
3	1518	R/H W BURNER ELECTRODE
4	82013-01	SWITCH WIRE
5	1516-44	GRILL INFRA RED ELECT.
6	1515-54	ROTIS INFRA RED ELEC.
7	82418	H.E. ELECTRONIC SWITCH
8	87040-01	9 VOLT BATTERY
9	XXXX	GROUND CABLE
A	82013-06	WIRE 44" FOR LIGHTS TO TRANSF.
B	82013-07	WIRE 60" FOR SWITCH TO LIGHTS
C	82013-04	WIRE 38" FOR SWITCH TO TRANSF.
D	83	CERAMIC WIRE NUT
E	82409	LIGHT SWITCH
F	82419	BBQ LIGHTS

1

1

PSQ40RC WIRING DIAGRAM # 82012-03

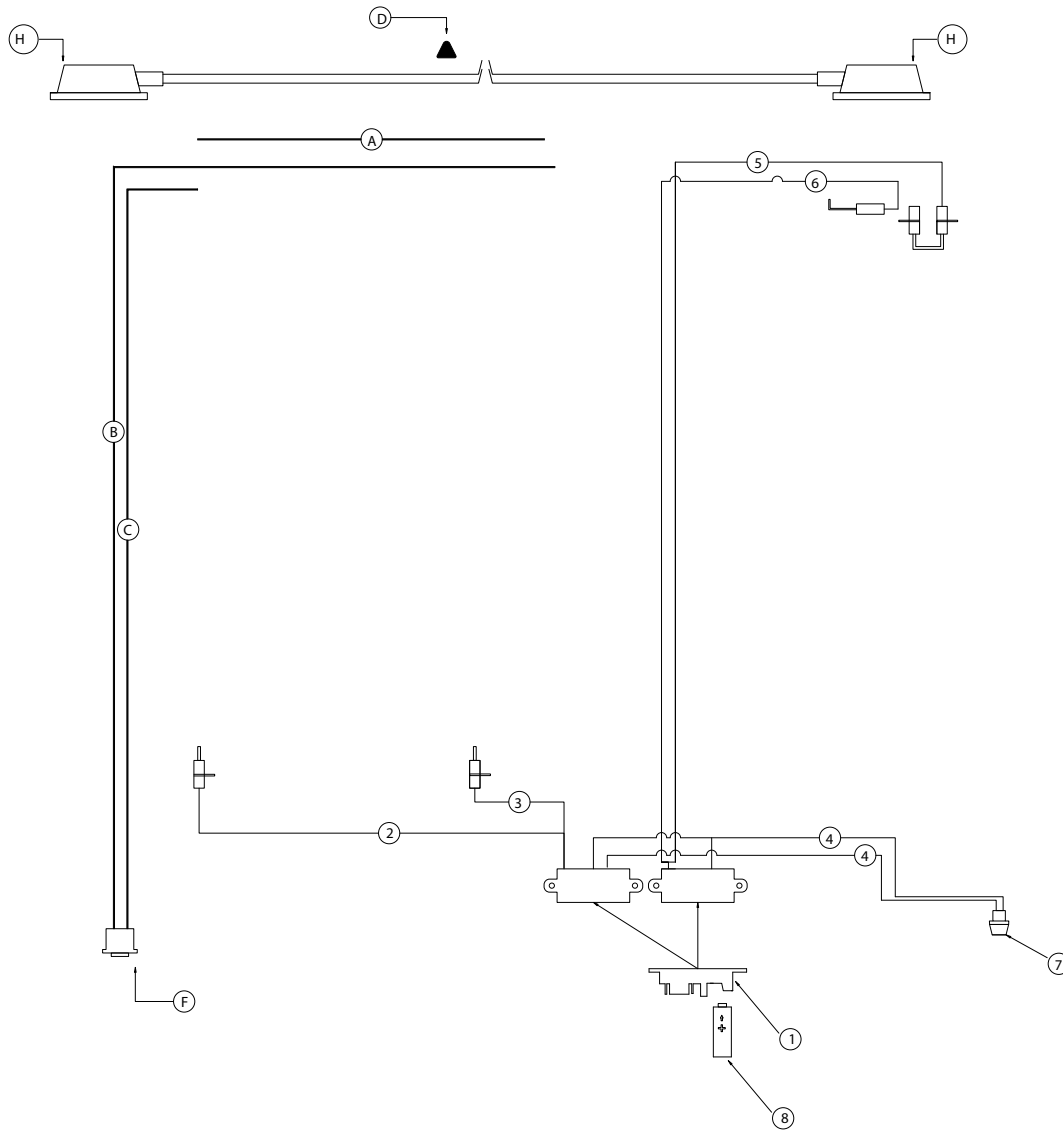

ITEM	PART NUMBER	DESCRIPTION
1	82417-01	H.E. ELECTRONIC IGNITER
2	1517	L/H W BURNER ELECTRODE
3	1518	R/H W BURNER ELECTRODE
4	82013-05	SWITCH WIRE
5	1516-32	GRILL INFRA RED ELECT.
6	1515	ROTIS INFRA RED ELECT.
7	82418	H.E. ELECTRONIC SWITCH
8	87040-01	9 VOLT BATTERY
A	82013-02	WIRE 36" FOR LIGHTS TO TRANSF.
B	82013-03	WIRE 52" FOR SWITCH TO LIGHTS
C	82013-04	WIRE 38" FOR SWITCH TO TRANSF.
D	83	CERAMIC WIRE NUT
E	82409	LIGHT SWITCH
F	82419	BBQ LIGHTS

1
1

PSQ30RC WIRING DIAGRAM # 82012-04

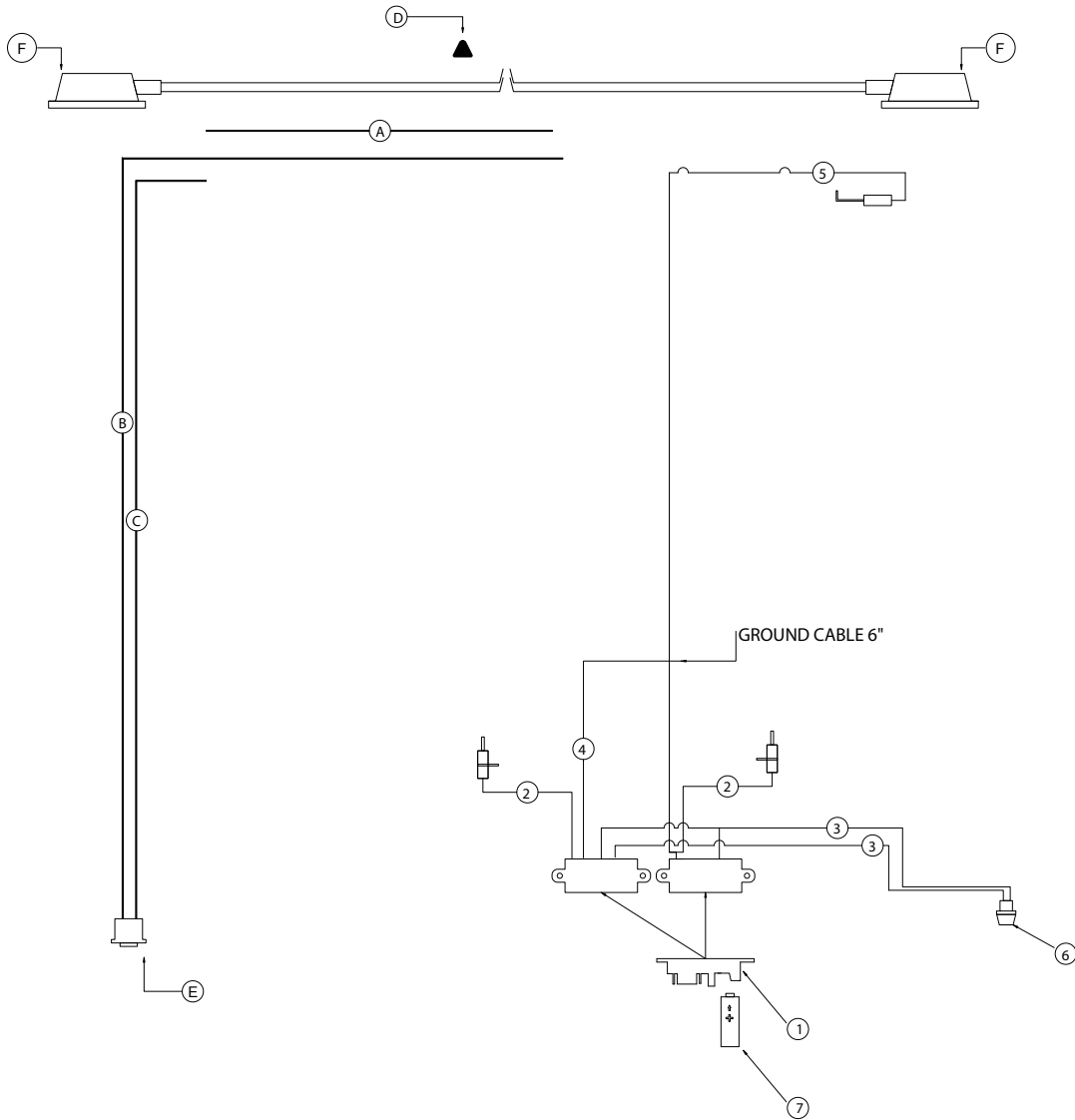

ITEM	PART NUMBER	DESCRIPTION
1	82417-01	H.E. ELECTRONIC IGNITER
2	1518	R/H W BURNER ELECTRODE
3	82013-05	SWITCH WIRE
4	82014-02	GROUND CABLE
5	1515	ROTIS INFRA RED ELECT.
6	82418	H.E. ELECTRONIC SWITCH
7	87040-01	9 VOLT BATTERY
A	82013-02	WIRE 36" FOR LIGHTS TO TRANSF.
B	82013-03	WIRE 52" FOR SWITCH TO LIGHTS
C	82013-04	WIRE 38" FOR SWITCH TO TRANSF.
D	83	CERAMIC WIRE NUT
E	82409	LIGHT SWITCH
F	82419	BBQ LIGHTS

PSQ30BI WIRING DIAGRAM # 82012-05

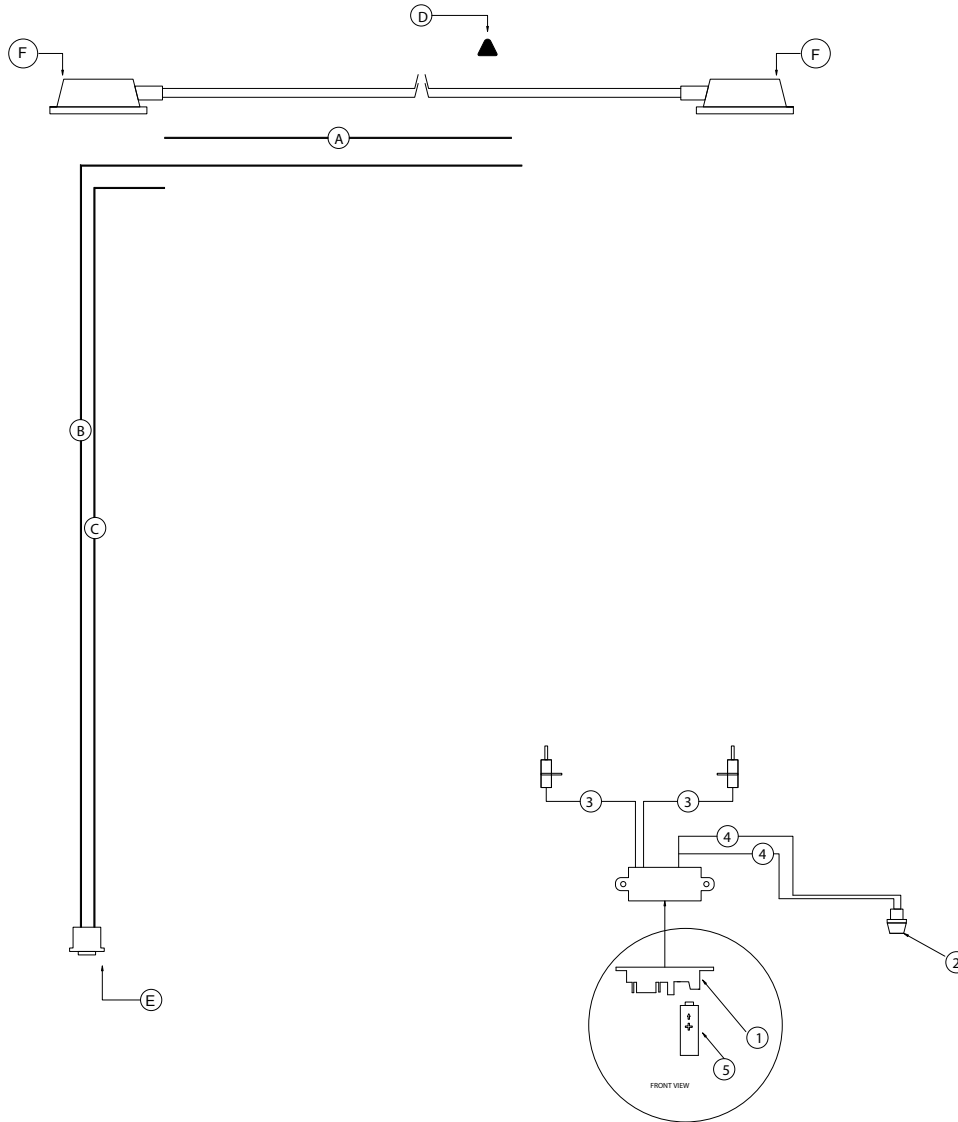

ITEM	PART NUMBER	DESCRIPTION
1	82417-01	H.E. ELECTRONIC IGN.
2	82418	H.E. ELECTRONIC SWITCH
3	1518	R/H W BURNER ELECTRODE
4	82013-10	SWITCH WIRE
5	87040-01	9 VOLT VATTERY
A	82013-02	WIRE 36" FOR LIGHTS TO TRANSF.
B	82013-03	WIRE 52" FOR SWITCH TO LIGHTS
C	82013-04	WIRE 38" FOR SWITCH TO TRANSF.
D	83	CERAMIC WIRE NUT
E	82409	LIGHT SWITCH
F	82419	BBQ LIGHTS

PSQSB2000 WIRING DIAGRAM # 82012-06

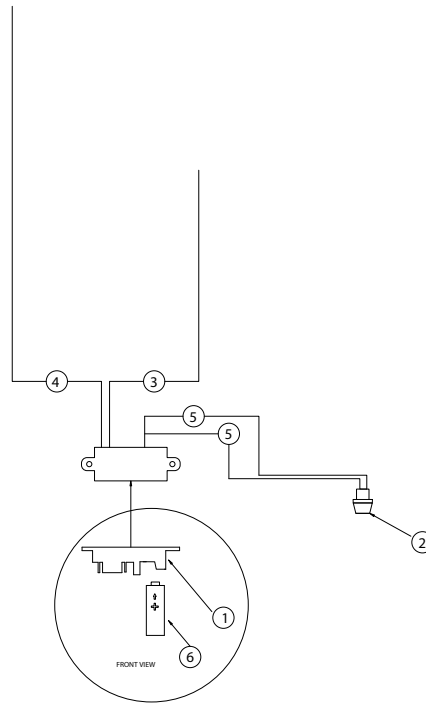

ITEM	PART NUMBER	DESCRIPTION
1	82417-01	H.E. ELECTRONIC IGN.
2	82418	H.E. ELECTRONIC SWITCH
3	23	SIDE BURNER WIRE
4	XXXX	SIDE BURNER WIRE
5	82013-10	SWITCH WIRE
6	1518	9 VOLT VATTERY

MODEL #	COOKING AREA IN SQ. IN.									
	A	B	C	D	E	F	G	H	I	
PSQ52RC	52	88	49	36	52	63	59	28		28.25
PSQ52RC-SB	52	88	49	36	52	63	59	28		28.25
PSQ40RC	40	76	49	36	52	63	47	28		28.25
PSQ40RBI	40	76	49	36	52	63	47	28		28.25
PSQ30RC	30	66	49	36	52	63	37	28		28.25
PSQ30ZRC	30	66	49	36	52	63	37	28		28.25
PSQ30XRBC	30	X	49	36	X	63	37	28		28.25
PSQ30RBI	30	66	49	36	52	63	37	28		28.25
PSQ30ZRBI	30	66	49	36	52	63	37	28		28.25

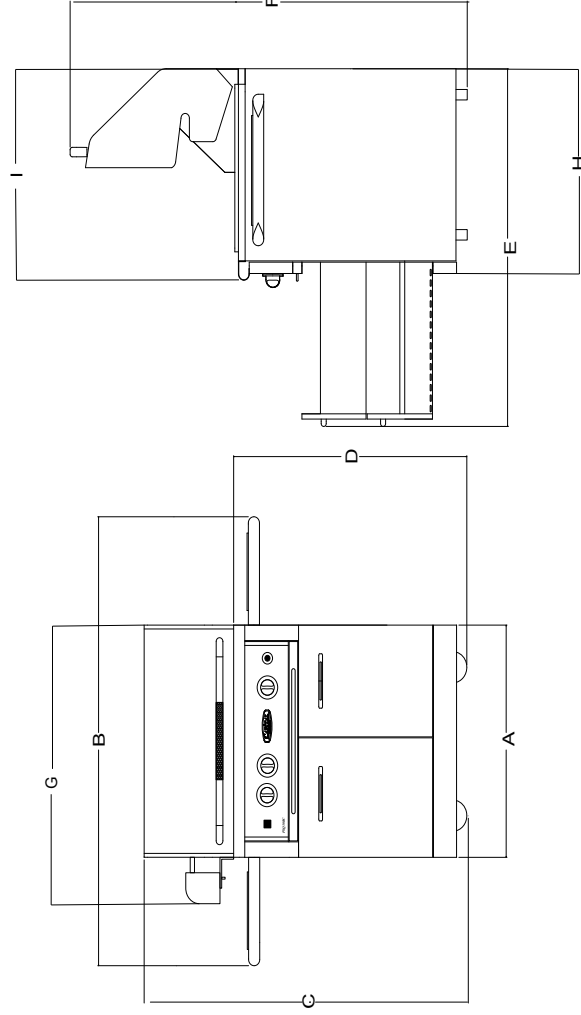

Shown: PSQ30RC

All illustrations and specifications contained in this use and care guide are based on the latest product information available at the time of this printing. Because product improvement is an ongoing process, Capital reserves the right to make changes at any time, without notice, in colors, materials, equipment, specifications, features and models. Some product pictures may be shown with optional equipment. Further information can be obtained from your authorized Capital Cooking Equipment dealer or visit us online at www.capital-cooking.com.

© 2006 Capital Cooking Equipment, Inc. Not to be reproduced wholly or in part without written permission from Capital Cooking Equipment, Inc.

Capital Cooking Equipment, Inc.
13211 Florence Ave.
Santa Fe Springs, Ca 90670 USA
1-866-402-4600 Toll Free
1-562-903-1167 Fax

MADE IN USA



UL and CUL certified for USA and Canada

PART #: 87050-01



THE POWER OF PERFORMANCE TM
