

Panasonic®

Operating Instructions

Microwave Oven
Models NN-S512
NN-S522

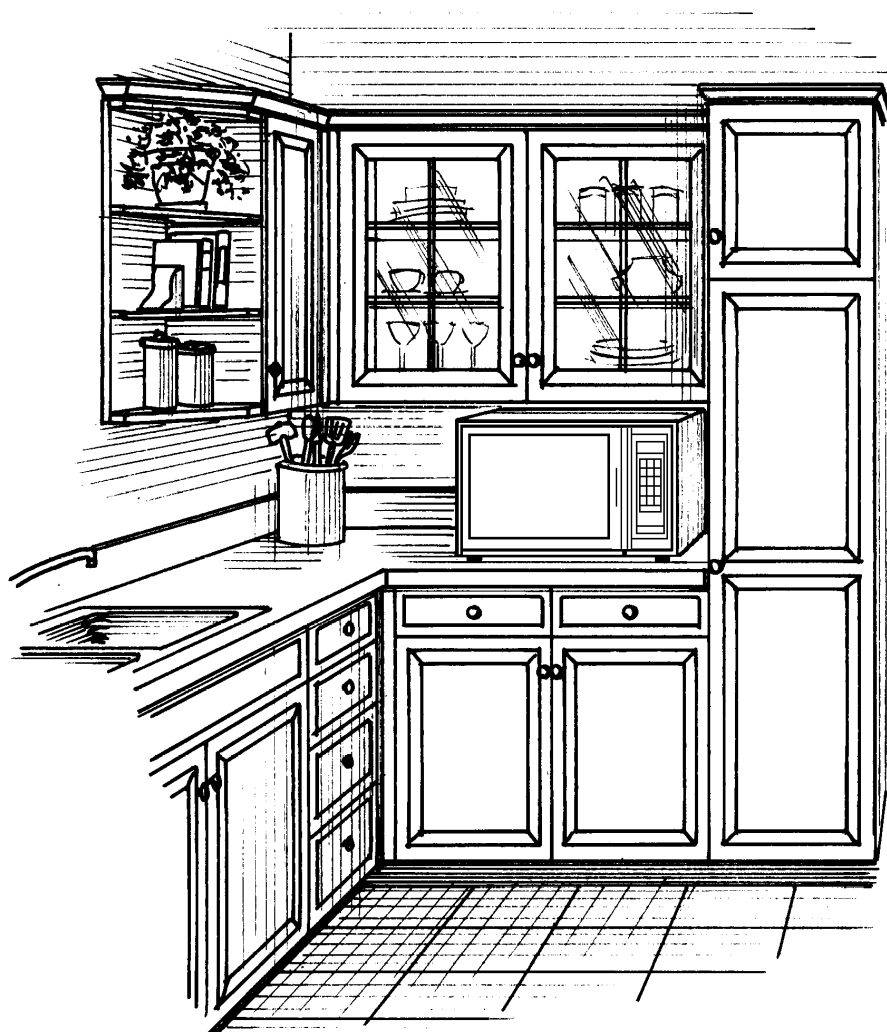

Before operating this oven, please read these instructions completely.

Warranty & Service

Panasonic Canada Inc.

5770 Ambler Drive, Mississauga, Ontario L4W 2T3

PANASONIC PRODUCT – LIMITED WARRANTY

Panasonic Canada Inc. warrants this product to be free from defects in material and workmanship and agrees to remedy any such defect for a period as stated below from the date of original purchase.

Microwave Oven: Two (2) years, parts and labour (Carry-in Service). Additional three (3) year warranty on the magnetron (parts only, labour extra). In-home Service applies to convection, over-the-range and stainless steel ovens.

(labour to install or remove the product is not warranted)

In-home Service will be carried out only to locations accessible by roads and within 50 km of an authorized Panasonic service facility.

LIMITATIONS AND EXCLUSIONS

This warranty does not apply to products purchased outside Canada or to any product which has been improperly installed, subjected to usage for which the product was not designed, misused or abused, damaged during shipping, or which has been altered or repaired in any way that affects the reliability or detracts from the performance, nor does it cover any product which is used commercially. Dry cell batteries are also excluded from coverage under this warranty.

This warranty is extended to the original end user purchaser only. A purchase receipt or other proof of date of original purchase is required before warranty service is performed.

THIS EXPRESS, LIMITED WARRANTY IS IN LIEU OF ALL OTHER WARRANTIES, EXPRESS OR IMPLIED, EXCLUDING ANY IMPLIED WARRANTIES OF MERCHANTABILITY OR FITNESS FOR A PARTICULAR PURPOSE.

IN NO EVENT WILL PANASONIC CANADA INC. BE LIABLE FOR ANY SPECIAL, INDIRECT OR CONSEQUENTIAL DAMAGES.

In certain instances, some jurisdictions do not allow the exclusion or limitation of incidental or consequential damages, or the exclusion of implied warranties, so the above limitations and exclusions may not be applicable.

WARRANTY SERVICE

For product operation and information assistance, please contact your Dealer or our Customer Care Centre at:
Telephone #: (905) 624-5505 Fax #: (905) 238-2360 Web: www.panasonic.ca

For product repairs, please contact one of the following:

- Your Dealer who will inform you of an authorized Servicentre nearest you.
- Our Customer Care Centre at (905) 624-5505 or www.panasonic.ca
- A Panasonic Factory Servicentre listed below:

Richmond, British Columbia

Panasonic Canada Inc.
12111 Riverside Way
Richmond, BC V6W 1K8
Tel: (604) 278-4211
Fax: (604) 278-5627

Calgary, Alberta

Panasonic Canada Inc.
6835-8th St. N. E.
Calgary, AB T2E 7H7
Tel: (403) 295-3955
Fax: (403) 274-5493

Mississauga, Ontario

Panasonic Canada Inc.
5770 Ambler Dr.
Mississauga, ON L4W 2T3
Tel: (905) 624-8447
Fax: (905) 238-2418

Lachine, Québec

Panasonic Canada Inc.
3075, rue Louis A. Amos
Lachine, QC H8T 1C4
Tel: (514) 633-8684
Fax: (514) 633-8020

IF YOU SHIP THE PRODUCT TO A SERVICENTRE

Carefully pack and send prepaid, adequately insured and preferably in the original carton.
Include details of the defect claimed, and proof of date of original purchase.

Important Safety Instructions

Your microwave oven is a cooking device and you should use as much care as you use with a stove or any cooking device. When using this electric appliance, basic safety precautions should be followed, including the following:

WARNING—To reduce the risk of burns, electric shock, fire, injury to persons or exposure to excessive microwave energy:

1. Read all instructions before using the appliance.
2. Read and follow the specific **PRECAUTIONS TO AVOID POSSIBLE EXPOSURE TO EXCESSIVE MICROWAVE ENERGY**, found on back of front cover.
3. This appliance must be grounded. Connect only to a properly grounded outlet. See “**GROUNDING INSTRUCTIONS**” found on page 3.
4. Install or locate this appliance only in accordance with the provided installation instructions.
5. Some products such as whole eggs and sealed containers—for example, closed glass jars—may explode and should not be heated in this oven.
6. Use this appliance only for its intended use as described in this manual. Do not use corrosive chemicals or vapours in this appliance. This type of oven is specifically designed to heat or cook food. It is not designed for industrial or laboratory use.
7. Do not allow children to use this appliance, unless closely supervised by an adult.
8. Do not operate this appliance if it has a damaged cord or plug, if it is not working properly, or if it has been damaged or dropped.
9. This appliance should be serviced only by qualified service personnel. Contact the nearest authorized servicentre for examination, repair or adjustment.
10. Do not cover or block any openings on this appliance.
11. Do not store or use this appliance outdoors. Do not use this product near water—for example, near a kitchen sink, in a wet basement, or near a swimming pool, etc.
12. Do not immerse the cord or plug in water.
13. Keep the cord away from heated surfaces.
14. Do not let the cord hang over the edge of a table or counter.
15. When cleaning surfaces of the door and oven that come together when closing the door, use only mild, non-abrasive soaps or detergents applied with a sponge or soft cloth.
16. To reduce the risk of fire in the oven cavity:
 - (a) Do not overcook food. Carefully attend the appliance if paper, plastic, or other combustible materials are placed inside the oven to facilitate cooking.
 - (b) Remove wire twist-ties from paper or plastic bags before placing the bag in the oven.
 - (c) If materials inside the oven should ignite, keep the oven door closed, turn the oven off, and disconnect the power cord, or shut off the power at the fuse or circuit breaker panel.
- (d) Do not use the cavity for storage purposes. Do not leave paper products, cooking utensils, or food in the cavity when not in use.
17. Liquids, such as water, coffee, or tea are able to be overheated beyond the boiling point without appearing to be boiling due to surface tension of the liquid. Visible bubbling or boiling when the container is removed from the microwave oven is not always present. **THIS COULD RESULT IN VERY HOT LIQUIDS SUDDENLY BOILING OVER WHEN A SPOON OR OTHER UTENSIL IS INSERTED INTO THE LIQUID.** To reduce the risk of injury to persons:
 - (a) Do not overheat the liquid.
 - (b) Stir the liquid both before and halfway through heating it.
 - (c) Do not use straight-sided containers with narrow necks.
 - (d) After heating, allow the container to stand in the microwave oven for a short time before removing it.
 - (e) Use extreme care when inserting a spoon or other utensil into the container.

General Use

1. **DO NOT** tamper with, or make any adjustments or repairs to, the door, control panel housing, safety interlock switches or any other part of the oven. **DO NOT** remove the outer panel from the oven. Repairs should only be done by qualified service personnel.
2. **DO NOT** operate the microwave when the oven is empty. The microwave energy will reflect continuously throughout the oven causing overheating, if no food or water is present to absorb energy.
3. **DO NOT** use this oven to heat chemicals or other non-food products.
4. **DO NOT** dry clothes, newspapers or other materials in the oven. They may catch on fire.
5. **DO NOT** use recycled paper products unless the paper product is labelled as safe for microwave oven use. Recycled paper products may contain impurities which may cause sparks and/or fires when used.
6. **DO NOT** use newspapers or paper bags for cooking.
7. **DO NOT** hit or strike the control panel. Damage to the controls may occur.
8. **DO NOT** store flammable materials next to, on top of, or in the oven. These could be fire hazards.
9. **POT HOLDERS** should always be used when removing containers from the oven. Heat is transferred from the hot food to the cooking container and from the cooking container to the Glass Tray. The glass tray can be very hot after removing a cooking container from the oven.

Save These Instructions

Installation and Grounding Instructions

Examine Your Oven

Unpack oven, remove all packing material, and examine the oven for any damages such as dents, broken door latches or cracks in the door. Notify dealer immediately if oven is damaged. **DO NOT** install if oven is damaged.

Placement of Oven

- Oven must be placed on a flat, stable surface. For proper operation, the oven must have sufficient air flow. Allow 8 cm (3") of space on both sides of the oven and 2.5 cm (1") of space on top of oven.
 - DO NOT** block air vents.
If they are blocked during operation, the oven may be overheated and damaged.
When using any cloth over the oven, the air intake and exhaust should not be blocked.
Allow proper space on back and both sides of oven.
 - DO NOT** place oven near a hot damp surface such as a gas or electric range, or dishwasher.
 - DO NOT** operate oven when room humidity is too high.
- This oven was manufactured for household use only.

Installation for Trim Kit

- This oven is designed for installation into a wall cabinet by using the proper trim kit (NN-TK529WAPH) available from a local Panasonic dealer. Follow all installation instructions packed with the kit.
- DO NOT** block air vents. If they are blocked during operation, the oven may overheat. If the oven overheats, a thermal safety device will turn the oven off. The oven will remain inoperable until it has cooled.
- This oven was manufactured for household use only.

Grounding Instructions

This appliance must be grounded. In the event of an electrical short circuit, grounding reduces the risk of electric shock by providing an escape wire for the electric current. This appliance is equipped with a cord having a grounding wire with a grounding plug. The plug must be plugged into an outlet that is properly installed and grounded.

WARNING—Improper use of the grounding plug can result in a risk of electric shock. Consult a qualified electrician or service person if the grounding instructions are not completely understood, or if doubt exists as to whether the appliance is properly grounded. If it is necessary to use an extension cord, use only a three wire extension cord that has a three blade grounding plug, and a three slot receptacle that will accept the plug on the appliance. The marked rating of the extension cord should be equal to, or greater than, the electrical rating of the appliance.

Wiring Requirements

- The oven must be operated on a SEPARATE CIRCUIT. No other appliance should share the circuit with the microwave oven. If it does, the branch circuit fuse may blow or the circuit breaker may trip, or the food may take longer to cook than the times recommended in this manual.
- The VOLTAGE used must be the same as specified on this microwave oven (120 V, 60 Hz). Using a higher voltage is dangerous and may result in a fire or another accident causing oven damage. Using a lower voltage will cause slow cooking. Panasonic is **NOT** responsible for any damages resulting from the use of the oven with any voltage other than specified.
- The oven must be plugged into at least a 15 AMP, 120 VOLT, 60 Hz GROUNDED OUTLET. Where a standard two-prong outlet is encountered, it is the personal responsibility and obligation of the consumer to have it replaced with a properly grounded three-prong outlet.

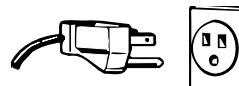

Glass Tray

- DO NOT** operate the oven without the Roller Ring and the Glass Tray in place.
- Only use the Glass Tray specifically designed for this oven. Do not substitute any other glass tray.
- If the Glass Tray is hot, allow to cool before cleaning or placing in water.
- DO NOT** cook directly on the Glass Tray. Always place food in a microwave-safe dish, or on a rack set in a microwave-safe dish.
- If the food or utensil on the Glass Tray touches oven walls, causing the tray to stop moving, the tray will automatically rotate in the opposite direction. This is normal.
- The Glass Tray can turn in either direction.

Roller Ring

- The Roller Ring and oven floor should be cleaned frequently to prevent excessive noise.
- The Roller Ring must always be used for cooking along with the Glass Tray.
- Always replace the Roller Ring and the Glass Tray in their proper positions.

Care of your Microwave Oven

1. Turn the oven off before cleaning. Make sure parts are cool.
2. Keep the inside of the oven clean. When food spatters or spilled liquids adhere to oven walls, wipe with a damp cloth. Mild detergent or liquid cleansers may be used if the oven gets very dirty. The use of harsh detergent or abrasives is not recommended.
3. The outside oven surfaces should be cleaned with a damp cloth. To prevent damage to the operating parts inside the oven, water should not be allowed to seep into the ventilation openings.
4. Clean Control Panel with a soft, dry cloth. Do not use harsh detergents, abrasives or paper towelling. When cleaning the control panel, leave oven door open to prevent oven from accidentally turning on. After cleaning, press **Stop/Reset** Pad to return to time-of-day.
5. Steam will be given off when cooking food and collect on the oven walls and door. During conditions of high humidity, steam may occur on the outside of the oven and in no way indicates malfunction of the unit. Wipe dry with a soft cloth.
6. It is occasionally necessary to remove the glass tray for cleaning. Wash the tray in warm sudsy water or in a dishwasher.
7. The roller ring and oven cavity floor should be cleaned regularly to avoid excessive noise. Simply wipe the bottom surface of the oven with mild detergent, water or window cleaner and dry. The roller ring may be washed in mild sudsy water or dishwasher. Cooking vapours collect during repeated use, but in no way affect the bottom surface or roller rings wheels. When removing the roller ring from the cavity floor for cleaning, be sure to replace in the proper position.
8. Daily cleaning will prevent the accumulation of odours and soil.

Safety Precautions

Utensils

1. MICROWAVE BROWNING DISHES or GRILLS are designed for microwave cooking only. Preheating times vary depending on the size of the browning dish and food being cooked. Always follow instructions provided by the browning dish or grill manufacturer. DO NOT PREHEAT BROWNING DISH MORE THAN 6 MINUTES in microwave.
2. METAL CONTAINERS or dishes with metallic trim should not be used. Arcing (sparking) may occur.
3. METAL TWIST-TIES should not be used in the microwave oven, arcing will occur.
4. DO NOT use SEALED JARS or NARROW NECK bottles for cooking or reheating. They may shatter.
5. DO NOT use CONVENTIONAL THERMOMETERS in the microwave oven. They may cause arcing.
6. Remove PLASTIC STORE WRAPS, before cooking or defrosting in the oven.
7. If an oven cooking bag is used, prepare according to package directions. Do not use wire twist-tie to close bag. Instead use plastic tie, a piece of cotton string or a strip cut from the open end of the bag. Make six 1 cm (1/2") slits by closure. Place oven cooking bag in a dish slightly larger than the food being cooked.
8. When using foil, skewers, rack or utensils made of metal in the oven, allow at least 2.5 cm (1") of space between metal material and interior oven walls. If arcing occurs remove metal material (skewers, etc.) and/or transfer to a non-metallic container.
9. Do not use paper towels or cloths which contain a synthetic fiber woven into them, such as nylon. The synthetic fiber may cause the towel or cloth to ignite. Use paper toweling under supervision.

Food

1. **Do not use your oven for home canning** or the heating of any closed jar. Pressure will build up and the jar may explode. In addition, the microwave oven cannot maintain the food at the proper canning temperature. Improperly canned food may spoil and be dangerous to consume.
2. Small quantities of food or foods with low moisture content can dry out, burn or catch on fire when overheated. If a fire occurs, turn oven off and leave oven door closed. Disconnect the power cord or shut off power at the fuse or circuit breaker panel.
3. Popcorn can be popped in a suitable, microwaveable corn popper using manufacturer's directions OR prepackaged bags of microwave popcorn can be used with the preset **Popcorn** Pad program. Treat bag according to package directions.
4. Do not attempt to deep fry in your microwave oven. Temperature cannot be controlled and fat will erupt. Many microwave utensils cannot withstand the temperatures of heated oil, resulting in shattering or melting.
5. Do not boil eggs in their shell. Pressure will build up and the eggs will explode.
6. Potatoes, apples, egg yolks and whites, whole squash and sausages are examples of foods with nonporous skins. This type of food must be pierced before cooking, to prevent bursting.
7. Use fresh potatoes, and cook until just done. The potatoes will still feel soft to the touch, but firm when pierced with a fork. Overcooking causes dehydration and may cause a fire.
8. Heat only 1 frozen dinner or entree in the oven at a time. If dinner or entree is heated in a foil tray, leave at least 2.5 cm (1") of space between foil tray and oven walls.
9. Drying meats, fruits, vegetables and herbs is not recommended .
10. Do not use the oven for any reason other than the preparation of food.
11. Do not leave oven unattended.

Feature Diagram

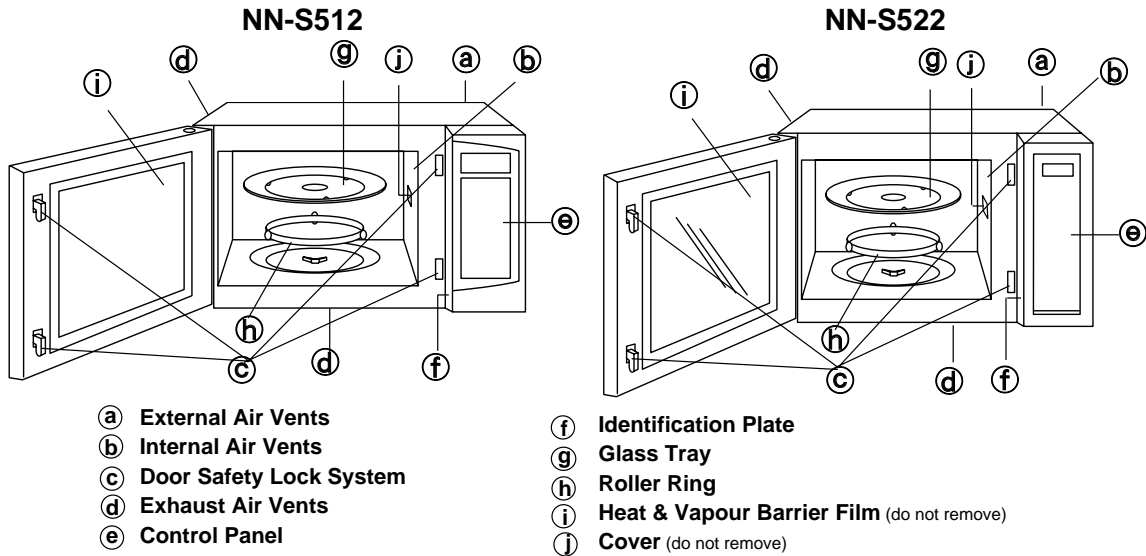

Oven Light:

Oven Light turns on only while cooking and will not turn on when oven door is opened.

Control Panel

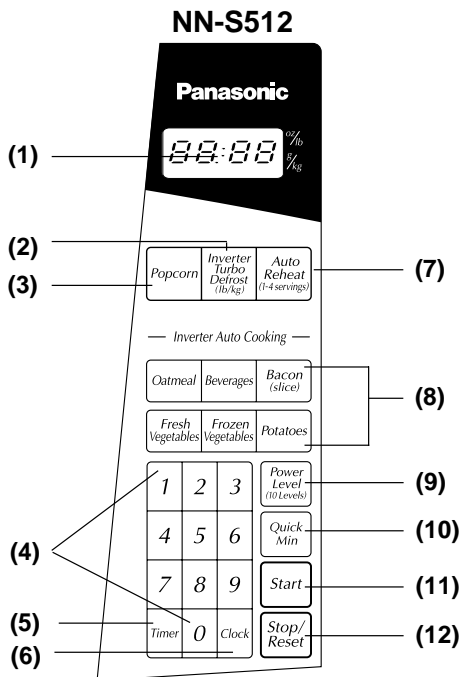

- (1) Display Window
- (2) Inverter Turbo Defrost Pad (←page 7)
- (3) Popcorn Pad (←page 7)
- (4) Number Pads
- (5) Timer Pad (←page 9)
- (6) Clock Pad (←page 6)
- (7) Auto Reheat Pad (←page 8)
- (8) Inverter Auto Cooking Pad (←page 8)
- (9) Power Level Pad (←page 6)
- (10) Quick Min Pad (←page 9)

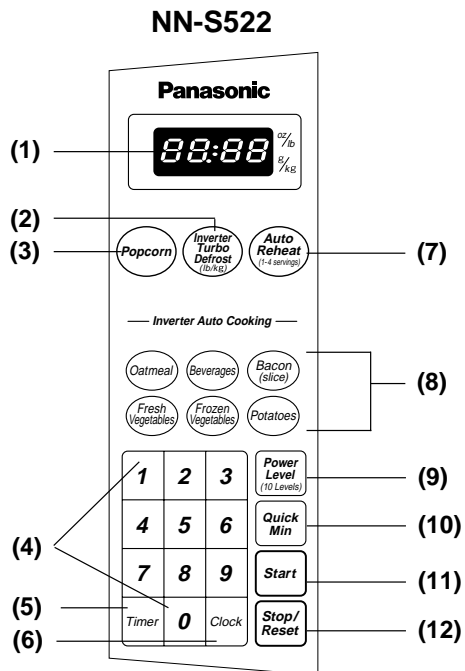

- (11) Start Pad
One tap allows oven to begin functioning. If door is opened or **Stop/Reset** Pad is pressed once during oven operation, **Start** Pad must again be pressed to restart oven.
- (12) Stop/Reset Pad
Before cooking: One tap clears your instruction.
During cooking: One tap temporarily stops the cooking process. Another tap cancels all your instructions and time of day or colon appears in the Display Window.

Operating Procedures

Using Timed Cook Programs

These are pre-timed for an average quantity of food. Local power fluctuations and personal tastes are not taken into account. Should you prefer food cooked differently, use power and time, as directed in the cooking guide section, other recipe sources or package directions. (See "To Use Auto Cook Pads" on page 8.)

To Use Inverter Turbo Defrost:

Use to defrost meat, poultry or seafood by using the weight on the package. Place food on microwave safe roasting rack in an appropriately sized dish.



1. Press **Inverter Turbo Defrost** Pad.

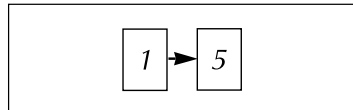

2. Enter weight using number pad.
e.g.: 1.5 kg or 1.5 lbs

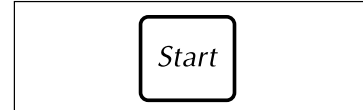

3. Press **Start** Pad.

- Halfway through defrosting, beep sounds. Turn over, rearrange foods, remove defrost areas or shield with aluminum foil.
- The recommended maximum weight of meat is 1.8 kg (4 lb); poultry, 2.7 kg (6 lb) and seafood, 1.4 kg (3 lb).
- The weight for **Inverter Turbo Defrost** can be programmed up to 3 kg (6 lb).
- Power and time may be programmed after **Inverter Turbo Defrost**.
- If you are using the Imperial system, be sure to convert oz to decimal equivalent, i.e., 8 oz = .5 lb, 4 oz = .25 lb etc.

To Use Popcorn:



1. Press **Popcorn** Pad until the desired weight appears on the Display Window.

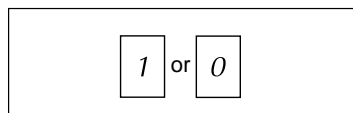

2. optional*

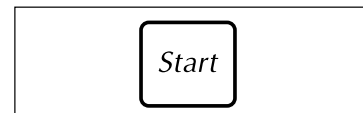

3. Press **Start** Pad. After several seconds, cooking time appears and begins to count down.

NOTES:

1. Popcorn packages should be at room temperature.
2. Place bag in oven according to manufacturer's directions.
3. Pop **one** bag at a time.
4. After popping, allow bag to cool. Carefully open bag away from face and body, since popcorn and steam are extremely hot.
5. **NEVER leave the oven unattended when popping popcorn. Stop the oven when popping slows to 2 to 3 seconds between pops. Overcooking may cause scorching.**
6. Do not reheat unpopped kernels or reuse bag.
7. With the many varieties of microwave popcorn available in the marketplace, it may be necessary for you to move the popcorn container to the outer edge of the glass tray to obtain the best cooking results.

REMARKS: When popping multiple bags one right after the other, the cooking times may vary slightly. This does not affect the popping results. To maintain the cooking quality for many brands of microwave popcorn available in the market, some preset weights have the same cooking time.

*To Use More/Less

When using popcorn pad, the weight may not be the same as the options offered. By using the number pad **1** or **0**, the programs can be adjusted to cook for a heavier or lighter weight.

Press **1** for More:



Press

1 tap = More⁺
2 taps = More⁺⁺

Press **0** for Less:



Press

1 tap = Less⁻
2 taps = Less⁻⁻

Popcorn serving

Press	Weight
once	3.5 oz.
twice	3.0 oz.
3 times	2.85 oz.
4 times	2.65 oz.
5 times	1.75 oz.

Operating Procedures

To Use Auto Reheat:



1. Press **Auto Reheat** Pad until the desired number of servings (1-4) appears on the **Display Window**.



2. Press **Start** Pad.

Type of Food	Quantity
Plate of Food Meat, Poultry Casseroles Soup, Gravy, Sauce	Usually 3-4 servings 1 piece 120 g (4 oz) 220 g (8 oz) 250 mL (1 cup)

To Use AUTO COOK Pads:

This feature allows you to cook most of your favourite foods without setting power and time.

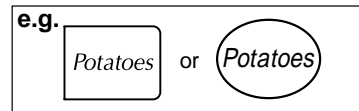

1. Press until the desired serving/weight appears on the **Display Window**.

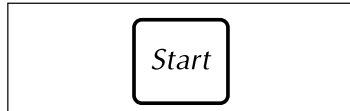

2. Press **Start** Pad. Cooking time will appear on the **Display Window** and begin to count down.

Category	Serving/Weight	Instructions
1. Oatmeal	0.5, 1 cup	Place inside a microwave-safe serving bowl with no cover. Follow manufacturers' directions for preparation of quick oatmeal.
2. Beverages	1, 2 cups	Use a microwave-safe coffee cup. Heated liquids can erupt if not mixed with air. Do not heat liquids in your microwave oven without stirring first.
3. Bacon (slice)	4 slices (3.2-4 oz.) (90-110 g) 6 slices (4.8-5.8 oz.) (135-165 g) 10 slices (8.1-9.5 oz.) (230-270 g) 14 slices (11.6-13 oz.) (330-370 g)	Place slices of bacon on a microwave-safe dish. Cover with paper towel. If bacon is not cooked to your liking, continue to heat by manually adding more time.
4. Fresh Vegetables	4, 8, 12, 16 oz (110, 225, 340, 450 g)	All pieces should be the same size. Add a small amount of water and cover loosely with a lid or vented plastic wrap.
5. Frozen Vegetables	6, 10, 16 oz (170, 300, 450 g)	Follow manufacturers' directions. Do not salt until after cooking. Not suitable for vegetables in butter or sauce.
6. Potatoes	1, 2, 3, 4 pieces (170-225 g each)	Pierce each potato with a fork 6 times spacing around surface. Place potato or potatoes around the edge of paper-towel-lined glass tray (Turntable), at least 1 inch (2.5 cm) apart. Do not cover. Let stand 5 minutes to complete cooking.

Operating Procedures

To Set Timer: (To use as a kitchen timer)

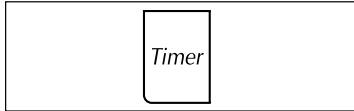

1. Press **Timer** Pad .

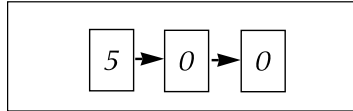

2. Enter length of time for count down.
e.g. 5:00 minutes

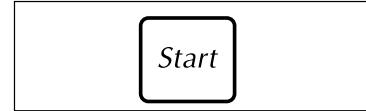

3. Press **Start** Pad.
Time will count down without oven operating.

- To delay the start of cooking for 20 minutes:

e.g. **TIMER** → 20 min. → **P10 (HIGH)** → 5 min. → **P6 (MED)** → 20 min. → **START**
 Delay Start Stage 1 Stage 2

- For standing time of 7 minutes after a cooking program of 1-2 stages:

e.g. **P3 (MED-LOW)** → 25 min. → **TIMER** → 7 min. → **START**
 Cook Program Standing Time

To Use Quick Min Function:

This feature allows you to set cooking times easily, instead of using Number Pads, or to add extra cooking time.

To Set Cooking Time:



1. Press **Quick Min** Pad to set cooking time (up to 10 minutes).



2. Press **Start** Pad. Cooking will start on **P10 (HIGH)** power.

- To use other power levels, select the desired power level before setting the cooking time.
- If you use **Quick Min** Pad to set your cooking time, you cannot use Number Pads to set more time or to change the cooking time. However, you can add more time with **Quick Min** Pad during cooking.

To Add Extra Cooking Time during cooking:



Press **Quick Min** Pad to add extra cooking time (up to 10 taps) during cooking.

- Cooking time changes to include extra time and continues to count down on the **Display Window**.
- Extra time can be added during any of the cooking stages.

To Use Child Safety Lock Control

Using this system will make the oven controls inoperable; however, the door will open. You can set the Child Lock when the display shows a colon or the time of day.

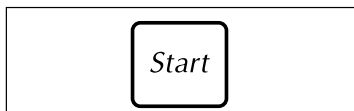

1. Press **Start** Pad three times.



Time of day will disappear and "Child" will appear on the **Display Window**. Actual time will not be lost.



2. To cancel "Child" press **Stop/Reset** Pad three times. Colon or time of day will reappear on the **Display Window**.

Cooking with Microwave Energy

Microwave energy is a form of high frequency electromagnetic energy much like radio waves. Electricity is converted by the magnetron into microwaves. In the oven, these waves are reflected by the metal oven walls and bounce around to assist in cooking food. Metal dishes may prevent food from cooking or cause arcing (bluish sparks), therefore, are not recommended. Arcing may damage the oven.

Microwaves pass through glass, paper, and plastic. These materials allow cooking from all sides.

Food absorbs microwave energy to a depth of 2 to 5 cm ($\frac{3}{4}$ " - $1\frac{1}{2}$ ")

The molecules, particularly water, fat and sugar, in food are excited, producing **heat of friction**; hence, cooking. Heat is **conducted** to the centre of food to finish cooking.

Microwave cooking utilizes the moisture in food for cooking, which keeps food from drying.

Room **temperature** foods will cook faster than refrigerated or frozen. **Dense** foods, such as potatoes, will take much longer to cook than porous food, such as cake.

Cooking time will increase with the **quantity**. Two potatoes will take twice as long as one.

Choose items of the **same size and shape** to cook together or cut them in similar sizes. When items have an irregular shape, place the thick areas toward the outside of the dish.

Thin or bony areas may be **shielded** with small pieces of aluminum foil for one third the cooking time. Make sure pieces of foil are kept 3 cm (1") away from each other and the oven walls, to prevent arcing.

Arrange or space foods evenly and in a circular pattern.

Rearrange uneven shapes and dense food, especially poultry, once or twice during cooking, by **turning over**.

Stir mixtures at least once and sauces several times, to allow even thickening. Some ingredients may heat faster, or to a higher temperature than others.

Some foods may not **brown** as in conventional cooking, due to the absence of heat and the short cooking period. Foods such as meat, may be colour and flavour enhanced by Kitchen Bouquet, soya sauce or powdered colour and flavour mixes, spices such as paprika and celery salt. For baked items, substitute whole wheat flour and brown sugar.

Foods with a **skin**, such as egg yolk, egg white, liver, sausage, clams, oysters and whole vegetables should be **pierced** so they do not burst.

Foods usually benefit from **covering** to hold in the heat. Use matching lids and microwaveable plastic wrap for steaming, and white paper towel and waxed paper to prevent spattering and hold in heat. When removing covers, **use care** to prevent steam burns. Some foods will not require a cover.

Time cooking for the least amount of time suggested. Food will continue to cook during **standing time**, which may be in or out of the oven. Extra cooking time may be added after standing time. Fat and bone can make food cook at an irregular rate.

Check poultry and meat with a meat thermometer to determine **doneness**. Poultry should reach 85°C (185°F), have clear juices when pierced and be steaming hot. Fish is cooked when opaque and flakes with a fork. Cakes are done when they pull away from the edge of the pan and a wooden pick inserted in the centre comes out clean.

Power Levels

Press	Power Level
once	P10 (HIGH)
twice	P9
3 times	P8
4 times	P7 (MEDIUM-HIGH)
5 times	P6 (MEDIUM)
6 times	P5
7 times	P4
8 times	P3 (MEDIUM-LOW)
9 times	P2
10 times	P1 (LOW)

Using other cookbooks

You may use other microwave cookbooks to expand your selection of recipes. Panasonic ovens may cook about 10% faster than other ovens or older ovens. There are two methods to adjust recipes:

- Select one power level lower than your recipe requires and use the recommended cooking time; OR
- Reduce the cooking time by 10%, but use the recommended power level.

Always check food before the shortest cooking time has elapsed.

Cookware and Utensil Guide

ITEM	MICROWAVE	COMMENTS
Aluminum Foil	for shielding	Small strips of foil can be molded around thin parts of meat or poultry to prevent overcooking. Arcing can occur if foil is too close to the oven wall (rack).
Browning Dish	Yes	Check browning dish information for instructions and heating chart. Do not preheat for more than 6 minutes.
Dinnerware Oven/Microwave Safe Non-Oven Safe	Yes use dish test below*	Check manufacturers' use and care directions for suitability for microwave heating. Some dinnerware may state on the back of the dish, "Microwave Oven Proof." Do not use cracked or chipped dishes.
Frozen Dinner Tray Metal	Yes	Frozen dinners may be heated in foil tray, if tray is less than 2 cm (3/4-inch) high. Place foil tray in centre of oven. Leave at least 2.5 cm (1-inch) space between foil tray and oven walls. Heat only 1 foil tray in the oven at a time. For containers more than 2 cm (3/4-inch) deep, remove and place in a similar size microwave-safe container.
Plastic	Yes	
Glass-Ceramic	Yes	If in doubt, use container test described below.
Metal Bakeware	No	Not recommended for use with microwave.
Metal Twist Ties	No	They may cause arcing which could cause a fire in the oven.
Microwave Rack	Yes	Often made of plastic.
Oven Cooking Bags	Yes	Follow manufacturers' directions. Close bag with either the nylon tie provided, a strip cut from the end of the bag, or a piece of cotton string. Do not close with a metal twist tie. Make six 1 cm (1/2-inch) slits by closure.
Ovenable Glassware	Yes	Do not use cracked or chipped dishes.
Ovenable Paperboard	Yes	Use with supervision.
Paper bags	No	May cause a fire in the oven.
Paper Towels/Napkins/Plates	with supervision	Never use recycled paper.
Parchment Paper	Yes	Use as a cover to prevent spattering.
Plastic Cookware: Microwave-Safe Non-Microwave Safe (Melamine)	Yes No	Should be labelled, "Suitable for microwave heating." Check manufacturers' directions for recommended uses. Some microwave-safe plastic dishes are not suitable for cooking foods with high fat content.
Plastic foam cups	short term	Use to bring foods to a low serving temperature. Foam will melt if foods reach a high temperature.
Plastic Wrap	Yes	Use to cover foods during cooking to retain moisture.
Thermometers Microwave-safe, only Conventional	Yes No	Meat and candy thermometers are available.
Waxed paper	Yes	Use as a cover to prevent spattering and to retain moisture.

* **To test a porcelain container for safe microwave oven use:** Fill a 250 mL (8 oz) glass beaker with water and place it in the microwave oven along with the container to be tested; heat one minute at **P10 (HIGH)**. If the container is microwave oven-safe (transparent to microwave energy), it should remain comfortably cool and the water should be hot. If the container is hot, it has absorbed some microwave energy and should not be used. This test cannot be used for plastic containers. Check manufacturers' directions to determine if material is heat safe to 200°C (400° F).

Microwave Helpful Hints

FOOD	POWER	COOKING TIME (in minutes)	DIRECTIONS
Bacon , to separate, 500 g (1 lb)	P10(HIGH)	1/2	Remove the wrapper. After heating, use a plastic spatula to separate slices.
Brown Sugar , to soften	P10(HIGH)	30 to 40 seconds	Place 250 mL (1 cup) hard brown sugar in a dish with a slice of bread or a wedge of apple. Cover with plastic wrap.
Butter , to melt, 125 g (4 oz) Butter , to soften, 125 g (4 oz)	P6(MEDIUM) P3(MEDIUM-LOW)	1 to 1 1/2 1 to 1 1/2	Remove the wrapper and place the butter in a dish.
Canned Foods , 450 mL (16 oz) Soup , 284 mL (10 oz) plus water	P10(HIGH) P10(HIGH)	3 to 4 4 to 6	Remove from the can, place in a covered dish. Stir once.
Chocolate , to melt, 1 square 30 g (1 oz) Chocolate , to melt, 125 g (1/2 cup) chips	P10(HIGH) P10(HIGH)	1/2 to 1 1 to 1 1/2	Remove wrapper and place chocolate in a dish. Stir before adding more time and heating again. Chocolate holds its shape even when softened.
Coconut , to toast, 110 mL (1/2 cup)	P10(HIGH)	1 1/2 to 2	Place in a pie plate or bowl. Stir every minute.
Cream Cheese , to soften, 230 g (8 oz)	P3(MEDIUM-LOW)	1 1/2 to 2	Remove the wrapper and place in a microwave-safe dish.
Dried Fruits , to soften	P10(HIGH)	20 to 30 seconds	Place fruit in a small bowl and sprinkle with water. Cover with plastic wrap.
Frozen Pie , cooked slice whole pie	P10(HIGH) P6(MEDIUM)	2 to 4 18 to 20	Place on a plate. Elevate on an inverted pie plate.
Ice Cream Topping , to warm	P10(HIGH)	30 to 45 seconds	Place 1 cup of topping in a dish; stir twice..
Ice Cream , to soften, 2 L (8 cups)	P3(MEDIUM-LOW)	1 to 1 1/2	Check often to prevent melting.
Nuts , to roast, 375 mL (1 1/2 cups)	P10(HIGH)	4 to 5	Spread nuts in a 23 cm (9") pie plate. Stir every minute.
Sesame Seeds , to toast, 50 mL (1/4 cup)	P10(HIGH)	1 1/2 to 2	Place in a small bowl. Stir once every minute.
Syrup / Honey , to soften	P10(HIGH)	20 to 30 seconds	Uncover the container. Stir or shake once. May be repeated if still crystalline.
Tostada, Tortillas, Taco Shells , to soften	P10(HIGH)	20 to 40 seconds	Place 4 shells between damp paper towels.
Warm Pastry, Rolls	P10(HIGH)	10 to 15 seconds	Place on a rack or wrap in a paper towel.
Liquids: (For Soup / Beverages) Water 250 mL (8 oz) 500 mL (16 oz) Milk / Soup 250 mL (8 oz) 500 mL (16 oz)	P10(HIGH) P10(HIGH) P7(MEDIUM-HIGH) P7(MEDIUM-HIGH)	2 1/2 to 3 5 to 5 1/2 2 to 3 4 to 5	Heated liquids can erupt if not mixed with air. Do not heat liquids in your microwave oven without stirring first.
Hot Compress	P10(HIGH)	15 seconds	Wet a cotton wash cloth; fold and heat.
Remove Oven Odours	P10(HIGH)	5	Combine 250 mL (1 cup) water with the juice and peel of one lemon in a measuring cup. After heating, wipe interior of oven with a damp cloth.

Before Requesting Service

All these things are normal:

The oven causes interference with my TV.

Some radio and TV interference might occur when you cook with the microwave oven. This interference is similar to the interference caused by small appliances such as mixers, vacuums, blow dryers, etc. It does not indicate a problem with your oven.

Steam accumulates on the oven door and warm air comes from the oven vents.



























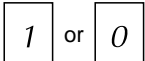



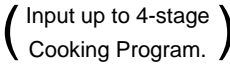

During cooking, steam and warm air are given off from the food. Most of the steam and warm air are removed from the oven by the air which circulates in the oven cavity. However, some steam will condense on cooler surfaces such as the oven door. This is normal.

I accidentally ran my microwave oven without any food in it.

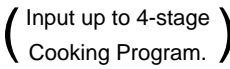
Running the oven empty for a short time will not damage the oven. However, we do not recommend operating the microwave oven without any food in it.

PROBLEM	POSSIBLE CAUSE	ACTION
Oven will not turn on.	The oven is not plugged in securely.	Remove plug from outlet, wait 10 seconds and reinsert.
	Circuit breaker or fuse is tripped or blown.	Reset circuit breaker or replace fuse.
	There is a problem with the outlet.	Plug another appliance into the outlet to check if it is working.
Oven will not start cooking.	The door is not closed completely.	Close the oven door securely.
	Start Pad was not pressed after programming.	Press Start Pad.
	Another program is already entered into the oven.	Press Stop/Reset Pad to cancel the previous program and enter a new program.
	The program is not correct.	Program again according to the Operating Instructions.
When the oven is operating, there is noise coming from the Glass Tray.	Stop/Reset Pad has been pressed accidentally.	Program oven again.
	The Glass Tray is not positioned properly on the Roller Ring or there is food under the Roller Ring.	Take out Glass Tray and Roller Ring. Wipe with a damp cloth and reset Roller Ring and Glass Tray properly.
The Glass Tray wobbles.	The Roller Ring and oven bottom are dirty.	Clean according to Care of Your Microwave Oven .

Quick Guide to Operation

Feature	How to Operate
To Set Clock (☞ page 6)	 Press. →  Enter time of day. →  Press.
Power and Time Setting (☞ page 6)	 Select power. →  Enter cook time. →  Press.
To Cook using Quick Min (☞ page 9)	 Tap desired number of times (up to 10). →  Press.
To Defrost using Manual Defrost (☞ page 6)	 Press 8 times to select P3. →  Enter defrosting time. →  Press.
Inverter Turbo Defrost (☞ page 7)	 Press. →  Enter weight. →  Press.
To Reheat using Auto Reheat (☞ page 8)	 Select serving (1-4). →  Press.
To Cook using Popcorn (☞ page 7)	 Press to select weight. →  Optional. →  Press.
To Use as a Timer (☞ page 9)	 Press. →  Enter time. →  Press.
To Set Standing time (☞ page 9)	 Press. →  Press. →  Enter time. →  Press.
To Set Delay time (☞ page 9)	 Press. →  Enter time. →  Press. →  Press.
To Cook using Inverter Auto Cooking Pads (☞ page 8)	e.g. Potatoes  or  →  Press.
To Use Child Safety Lock (☞ page 9)	 To Set: Press 3 times.
	 To Cancel: Press 3 times.

Thank you for purchasing a Panasonic Microwave Oven.

PRECAUTIONS TO AVOID POSSIBLE EXPOSURE TO EXCESSIVE MICROWAVE ENERGY

- (a) Do not attempt to operate this oven with the door open since open-door operation can result in harmful exposure to microwave energy. It is important not to defeat, or tamper with, the safety interlocks. Under normal conditions, the oven will not operate with the door open.
- (b) Do not place any object between the oven front face and the door, or allow soil or cleaner residue to accumulate on sealing surfaces.
- (c) Do not operate the oven if it is damaged. It is particularly important that the oven door closes properly and that there is no damage to the following:
 - (1) door (bent)
 - (2) hinges and latches (broken or loosened)
 - (3) door seals and sealing surfaces.
- (d) The oven should not be adjusted, or repaired, by anyone except properly qualified service personnel.

TABLE OF CONTENTS

Operating Instructions

Technical Specifications	below
Warranty & Service	1
Important Safety Instructions	2
Installation and Grounding Instructions	3
Care of Your Microwave Oven.....	4
Safety Precautions	4
Feature Diagram	5
Control Panel.....	5
Controls and Operating Procedures.....	6-9

Cooking Guide

Cooking with Microwave Energy	10
Cookware and Utensil Guide.....	11
Microwave Helpful Hints	12
Before Requesting Service	13
Quick Guide to Operation	14

Technical Specifications

	NN-S512/NN-S522
Electricity:	120 V, 60 Hz
Power Consumption:	11.5 A, 1,320 W
Output:*	1,200 W
Outside Dimensions (H x W x D):	301 mm x 518 mm x 404 mm
Oven Cavity Dimensions (H x W x D):	225 mm x 375 mm x 386 mm
Operating Frequency:	2,450 MHz
Uncrated Weight:	10.5 kg (23 lb)
Trim Kit:	NN-TK529WAPH (White)
Trim Kit Cabinet Opening:	576 x 389 mm

*IEC Test Procedure used

Specifications subject to change without notice.