

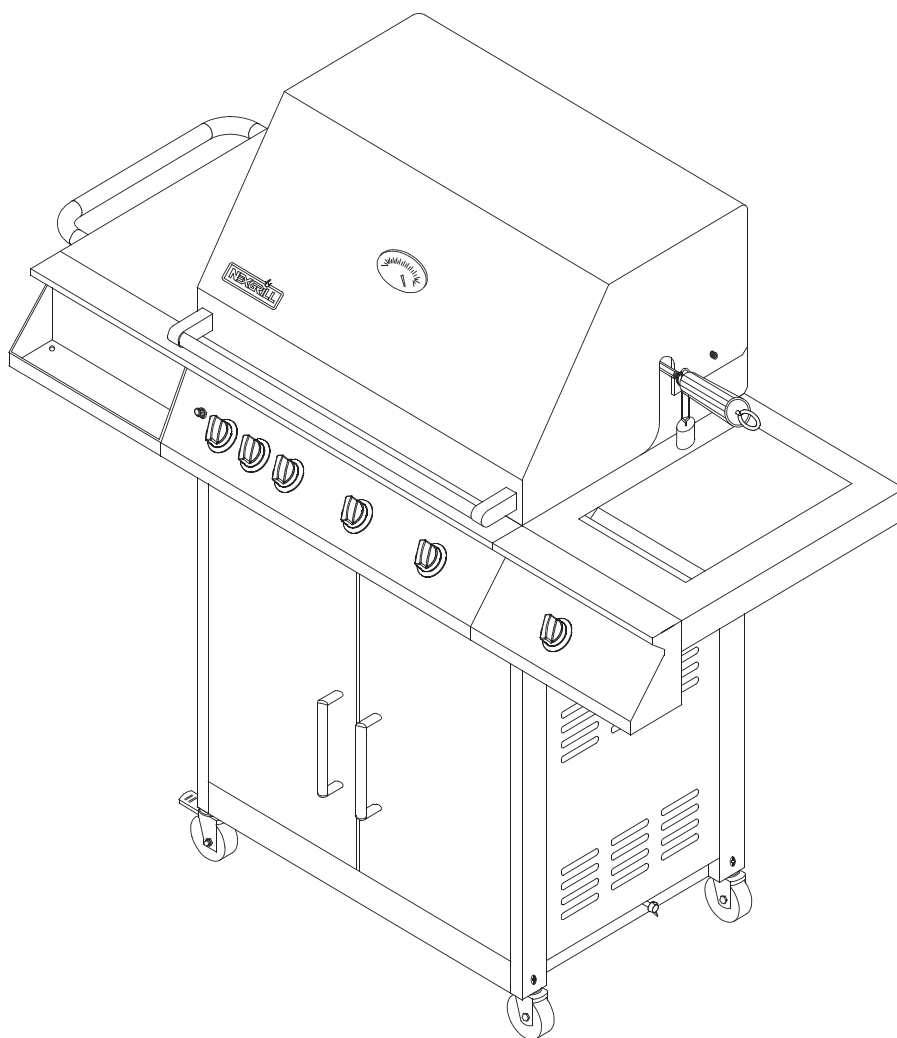

**Stainless Steel GAS GRILL
With Side Burner
USE AND CARE GUIDE
MODEL NO.: 720-0133-NG**



FOR OUTDOOR USE ONLY



**PLEASE CONTACT 1-800-648-5864 FOR ASSISTANCE
DO NOT RETURN TO PLACE OF PURCHASE**

MESSAGE TO OUR CONSUMERS

Thank you for selecting our stainless steel gas grill.

Because this appliance contains features which may not be found on other grills, we recommend that you read this entire booklet before your first use. Keep it in a handy place as it has answers to questions that may occur during future use.

Read this booklet carefully and be sure your gas grill is properly assembled, installed and maintained. Failure to follow these instructions could result in serious bodily injury and/or property damage. This gas grill is intended for outdoor use only and is not intended to be installed in or on recreational vehicles or boats.

NOTE TO INSTALLER: Leave these instructions with the consumer after installation.

NOTE TO CONSUMER: Retain for future reference.

TABLE OF CONTENTS

SECTION ONE

Precautions	1
Placement of the grill	3

SECTION TWO

Assembly instructions	4
Installation of the hose onto the NG Regulator.....	13

SECTION THREE

Gas hook-up	14
Leak testing	14
Installer final check list	15
Operating instructions	16
Grill lighting instructions	16
Lighting illustrations.....	18
To Match Light the Grill.....	18
Visual Checking Burner Flame.....	19

SECTION FOUR

Using the side burner	19
-----------------------------	----

SECTION FIVE

Care and maintenance	20
Troubleshooting	21

SECTION SIX

Parts list	23
Ordering parts	25
Grill hints	25

SECTION SEVEN

Grill Cooking Chart	26
---------------------------	----

SECTION EIGHT

Grill recipe suggestions	29
--------------------------------	----

SECTION NINE

Limited warranty	32
------------------------	----

PRECAUTIONS

FOR YOUR SAFETY

If you smell gas:

1. **Shut off gas to the appliance.**
2. **Extinguish any open flames.**
3. **Open lid.**
4. **If odor continues, immediately call your gas supplier.**

WARNING

Do not try to light this appliance without first reading the “LIGHTING INSTRUCTIONS” section in this manual.

FOR YOUR SAFETY

1. **Do not store or use gasoline or other flammable vapors and liquids in the vicinity of this or any other appliance.**

TESTED IN ACCORDANCE WITH ANSI Z21.58 / CGA 1.6 STANDARD FOR OUTDOOR COOKING GAS APPLIANCES. THIS GRILL IS FOR OUTDOOR USE ONLY.

Check your local building codes for the proper method of installation. In the absence of local codes, this unit should be installed in accordance with the National Fuel Gas Code ANSI Z223.1/NFPA 54, ANSI/NFPA 58 OR CGA B149.1 Natural Gas and Propane Installation Code, and the National Electrical Code, ANSI/NFPA 70, or the Canadian Electrical Code, CSA C22.1.

CALIFORNIA PROPOSITION 65-WARNING

The burning of gas fuel generates some by-products, which are on the list of substances, which are known by the State of California to cause cancer or reproductive harm. California law requires businesses to warn customers of potential exposure to such substances. To minimize exposure to these substances, always operate this unit according to the use and care manual, ensuring you provide good ventilation when cooking with gas.

SAFETY PRACTICES TO AVOID PERSONAL INJURY

When properly cared for, your stainless steel grill will give safe, reliable service for many years. However, extreme care must be used since the grill produces intense heat and that can increase accident potential. When using this appliance basic safety practices must be followed, including the following:

Read this Care and Use Manual carefully and completely before using your grill to reduce the risk of fire, burn hazard or other injury.

Do not repair or replace any part of the grill unless specifically recommended in this manual. All other service should be referred to a qualified technician.

CHILDREN SHOULD NOT BE LEFT ALONE OR UNATTENDED IN AN AREA WHERE THE GRILL IS BEING USED. NEVER ALLOW THEM TO SIT, STAND OR PLAY ON OR AROUND THE GRILL AT ANY TIME.

PRECAUTIONS

DO NOT STORE ITEMS OF INTEREST TO CHILDREN AROUND OR BELOW THE GRILL OR IN THE CART. NEVER ALLOW CHILDREN TO CRAWL INSIDE OF THE CART.

Never let clothing, pot holders or other flammable materials come in contact with or too close to any grate, burner or hot surface until it has cooled. Fabric may ignite and result in personal injury.

For personal safety, wear proper apparel. Loose fitting garments or sleeves should never be worn while using this appliance. Some synthetic fabrics are highly flammable and should not be worn while cooking.

Only certain types of glass, heat-proof glass ceramic, earthenware, or other glazed utensils are suitable for grill use. These types of materials may break with sudden temperature changes. Use only on low or medium heat settings according to the manufacturer's directions.

Do not heat unopened food containers as a build-up of pressure may cause the container to burst.

Use a covered hand when opening the grill lid. Never lean over an open grill.

WHEN LIGHTING A BURNER, ALWAYS PAY CLOSE ATTENTION TO WHAT YOU ARE DOING. BE CERTAIN YOU ARE TURNING THE IGNITER LABELED FOR THE BURNER YOU INTEND ON USING.

When using the grill, do not touch the grill rack, burner grate or immediate surroundings as these areas become extremely hot and could cause burns. Use only dry potholders.

Moist or damp potholders on hot surfaces may cause burns from steam. Do not use a towel or bulky cloth in place of potholders. Do not let potholders touch hot portions of the grill rack.

Grease is flammable. Let hot grease cool before attempting to handle it. Avoid letting excess grease deposits collect in the grease tray at the bottom of the grill's firebox. Clean often.

DO NOT USE ALUMINUM FOIL TO LINE THE GRILL RACKS OR GRILL BOTTOM. This can severely upset combustion air flow or trap excessive heat in the control area.

For proper lighting and performance of the burners keep the burner ports clean. It is necessary to clean them periodically for optimum performance. The burners will only operate in one position and must be mounted correctly for safe operation.

Clean the grill with caution. Avoid steam burns; do not use a wet sponge or cloth to clean the grill while it is hot. Some cleaners produce noxious fumes or can ignite if applied to a hot surface.

INSECT WARNING!!! Spiders and insects can nest in the burners of this and any other grill, and cause the gas to flow improperly. This is a very dangerous condition which can cause a fire to occur behind the value panel, thereby damaging the grill and making it unsafe to operate. Inspect the grill twice a year.

Be sure all grill controls are turned off and the grill is cool before using any type of aerosol cleaner on or around the grill. The chemical that produces the spraying action could, in the presence of heat, ignite or cause metal parts to corrode.

PRECAUTIONS

Do not use the grill for cooking excessively fatty meats or products which promote flare-ups. Do not operate the grill under unprotected combustible construction. Use only in well ventilated areas. Do not use in buildings, garages, sheds, breezeways or other such enclosed areas. *THIS UNIT IS FOR OUTDOOR USE ONLY.*

Keep the area surrounding the grill free from combustible materials, trash, or combustible fluids and vapors such as gasoline or charcoal lighter fluid. Maintain a minimum of 24" clearance away from combustible material. Do not obstruct the flow of combustion and ventilation air. If the unit is stored indoors ensure that it is cool.

DO NOT USE BRIQUETTES OF ANY KIND IN THE GRILL.

This stainless steel grill is designed for optimum performance without the use of briquettes. Do not place briquettes on the radiant as this will block off the area for the grill burners to vent. Adding briquettes can damage ignition components and knobs, and void the warranty.

Keep the back of the cart free and clear from debris. Keep any electrical supply cord, or the rotisserie motor cord away from the heated areas of the grill.

Never use the grill in extremely windy conditions. If located in a consistently windy area (oceanfront, mountaintop, etc.) a windbreak will be required. Always adhere to the specified clearance.

PLACEMENT OF THE GRILL

CLEARANCE

To Non-Combustible Construction

A minimum of 3" clearance from the back of the grill to non-combustible construction is required for the lid to open fully.

DO NOT INSTALL THIS UNIT INTO COMBUSTIBLE ENCLOSURES!

LOCATION

When determining a suitable location take into account concerns such as exposure to wind, proximity to traffic paths and keeping any gas supply lines as short as possible.

Locate the grill only in a well-ventilated area. Never locate the grill in a building, garage, breezeway, shed or other such enclosed areas without an approved ventilation system. During heavy use, the grill will produce a lot of smoke. Lock the wheels after the grill is placed in a suitable position according to the sticker located beneath the right door. Keep any electrical supply cord and the fuel supply hose away from any heated surfaces.

This outdoor cooking gas appliance shall be used only outdoor and shall not be used in a building, garage or any other enclosed area. This appliance is not intended to be installed in or on recreational vehicles and/or boats



ASSEMBLY INSTRUCTIONS

PLEASE READ THE INSTRUCTIONS CAREFULLY AND FOLLOW STEP BY STEP.

TOOLS REQUIRED:

- (1) PHILIPS HEAD SCREWDRIVER – NOT PROVIDED**
- (2) ALLEN WRENCH – PROVIDED FOR TIGHTENING SIDE BURNER CONTROL KNOB**
- (3) WRENCH – PROVIDED FOR TIGHTENING CASTERS**
- (4) FLAT HEAD SCREW DRIVER-NOT PROVIDED**
- (5) ADJUSTABLE OR 7/16” (11mm) OPEN END WRENCH-NOT PROVIDED**

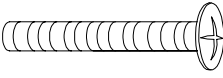
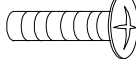
INCLUDED HARDWARE:

Item	Description	Specification	Quantity
1	philips head screw 	1/4× 20× 1 1/2(38mm)	8pcs
2	philips head screw 	1/4× 20× 1/2(15mm)	20pcs
3	philips head screw 	5/32× 32× 3/8(10mm)	12pcs

STEP 1: Remove side panel (marked “L”) and two 4” casters with Brakes from the carton . Put two casters and side panel marked “L” together with wrench provided. Repeat this step for the right side panel.

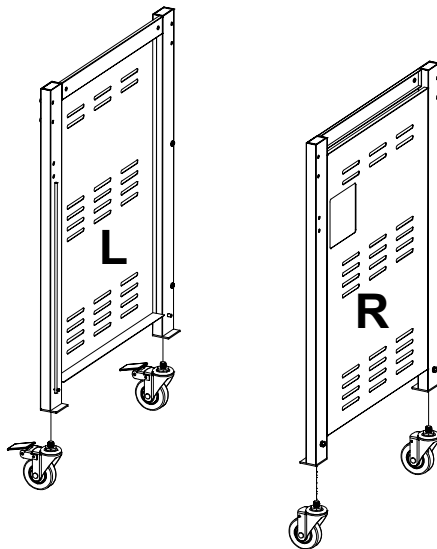

ASSEMBLY INSTRUCTIONS

STEP 2: Remove the upper portion of grill from carton, take off the protective foam & all parts under the lid, then put the bowl assembly on a protected surface and remove the main lid using an adjustable open end wrench on the caps from the inside. Keep the screws/caps in a safe place for replacing the lid back on (in step 8).

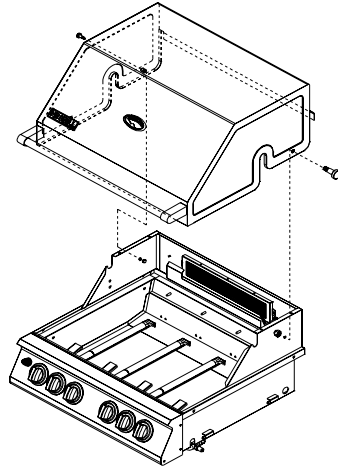

STEP 3A: Tip back the grill head have it lay on the floor. Line up and assemble the right & left side panels & secure with 4 1/4"x 20x1 1/2" screws from the four inside corners of the grill housing.

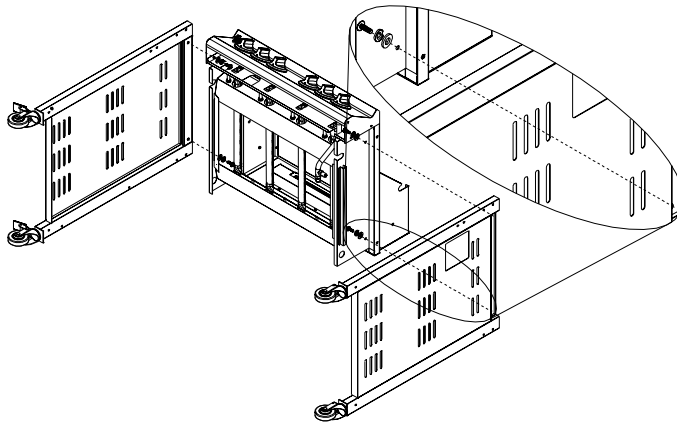

STEP 3B: Assemble bottom panel to side panels with 4-1/4 x 1 1/2" screws.

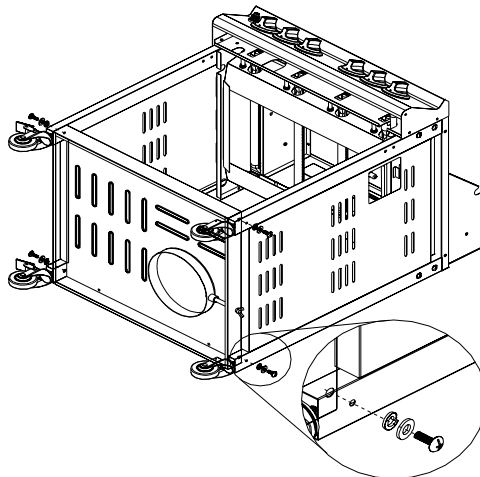

ASSEMBLY INSTRUCTIONS

STEP 4: Set the grill upright (Need a minimum of 2 people and use caution). Assemble back panel onto the grill cart with 2- 5/32 x 32 x 3/8 screws on the bottom and 4- 1/4 x 20 x 1/2 screws on the legs.

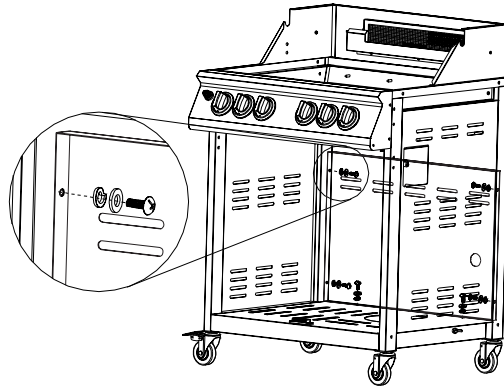

STEP 5A: Insert both doors' hinge pins through the holes on the bottom of the bottom panel. Make sure the washers are in place.

STEP 5B: Assemble the header frame on top of both doors by inserting the door hinge pins through the pre-drilled holes on the frame's bottom side. Push the door and frame unit into the cart and screw in the frame on both sides.

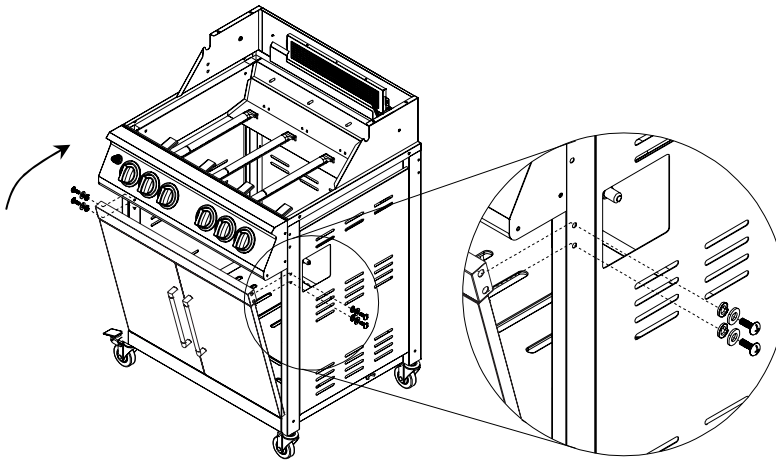

STEP 5C: Install the lid back in place using the same hardware kept from step 2.

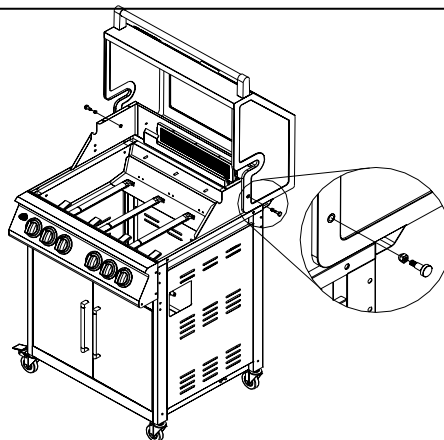

SIDE SHELF ASSEMBLY

STEP 6A: Use two screws and lock washers to fasten the condiment tray to the side shelf. Use two screws and lock washers to fasten the support brackets to the side shelf as illustrated.

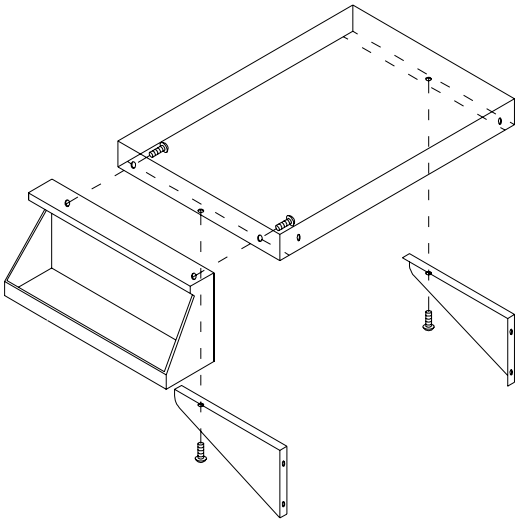

STEP 6B: Use two screws and lock washers to fasten the control panel to the side shelf. Do not tighten these screws until the valve stem protrudes through the control panel (step 8). Use two screws and lock washes to fasten the support brackets to the side burner as illustrated.

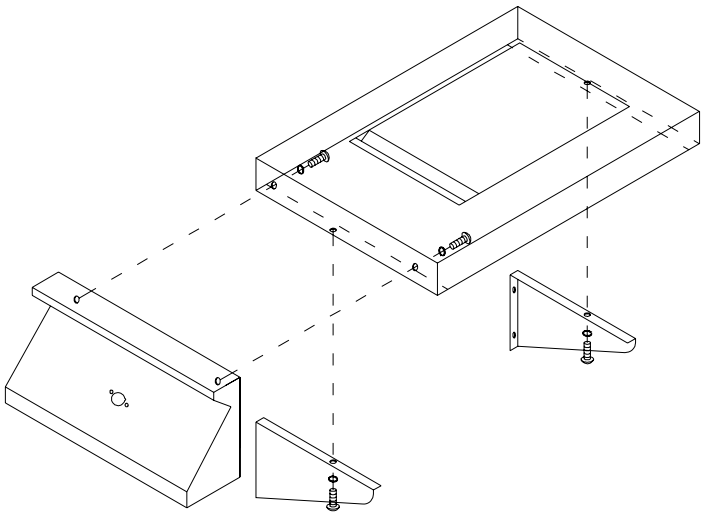

ASSEMBLY INSTRUCTIONS

STEP 6: Align the side shelves with the holes in the side panels of the grill, tighten each side shelf assembly into place, also tighten the screws taken from the shelf assemblies (step 3 figure B) back into each side shelf from inside the grill's cooking area.

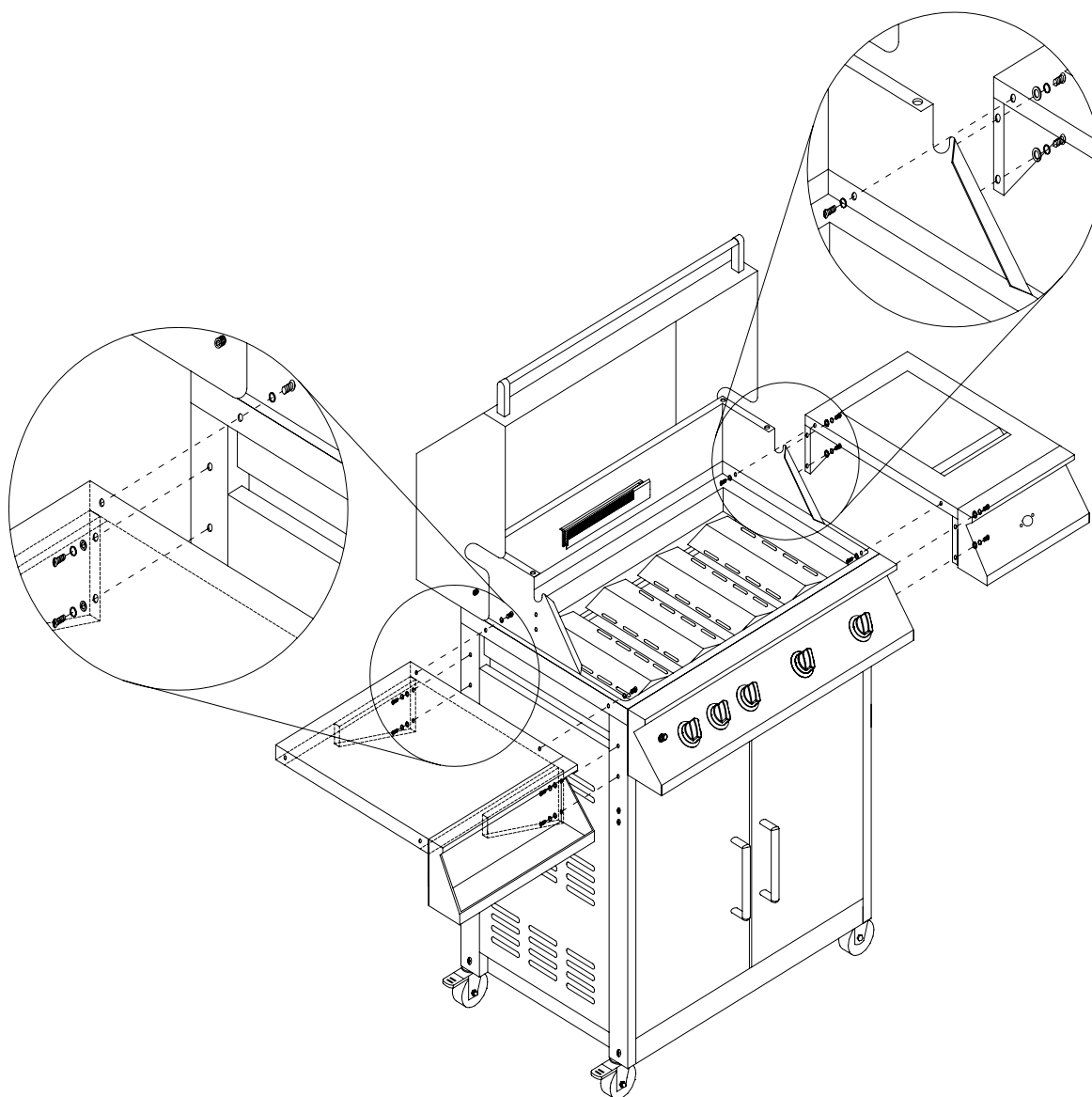

ASSEMBLY INSTRUCTIONS

Step 7: Insert valve assembly through side panel
(Side panel, right)

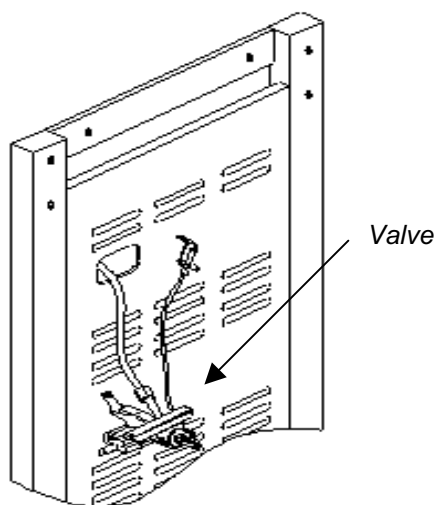

Step 8: Remove 4(four) screws & washers from the "U" brackets on the side burner

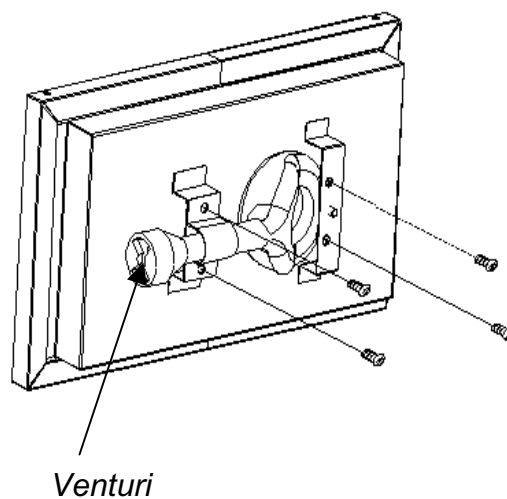

Step 9: Insert valve stem assembly into burner into venturi

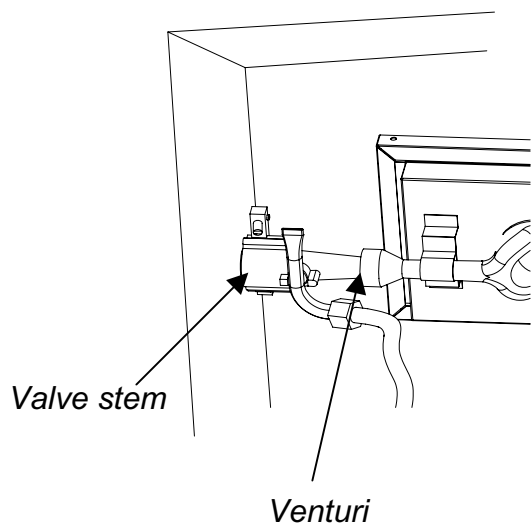

Step 10: Insert valve stem assembly face-plate.

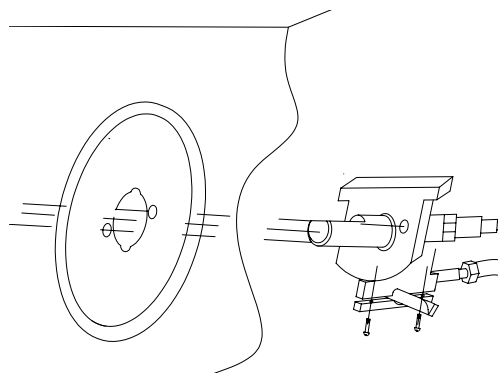

ASSEMBLY INSTRUCTIONS

Step 11: Replace "U" brackets with 4(four) Screws(**DO NOT TIGHTEN**) and stem with 2(two) screws & washers

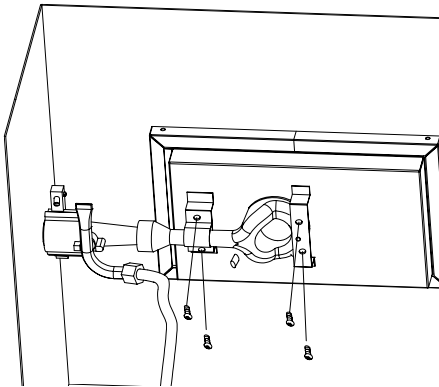

Step 12: Align & start knob bezel & valve Screws (**DO NOT TIGHTEN**)

as shown below.
(knob bezel in bag)

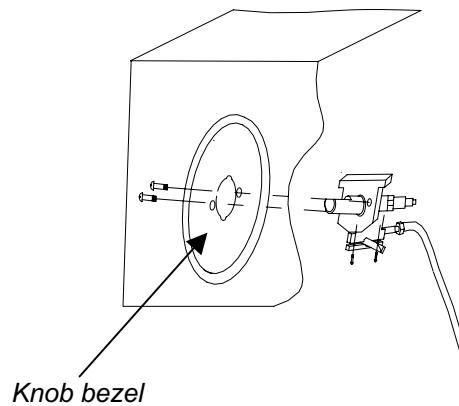

Step 13; Tighten all 4(four) screws on the "U" brackets on the burner, then connect the ignition wire on to valve.

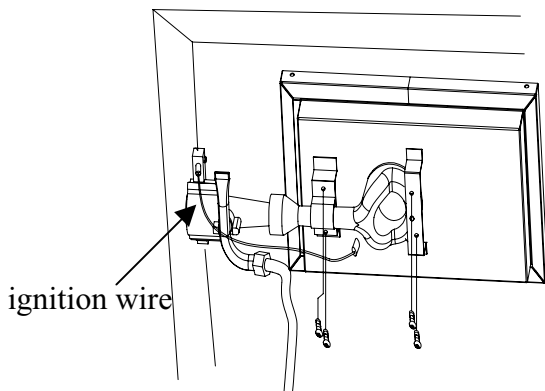

Step 14: Place knob on valve stem and secure with Allen wrench
(wrench enclosed in bag)

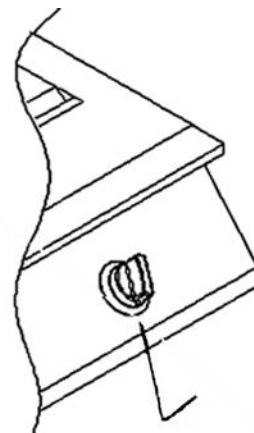

ASSEMBLY INSTRUCTIONS

STEP 15: Place flame tamers, cooking grids, warming rack and grease tray as shown below.

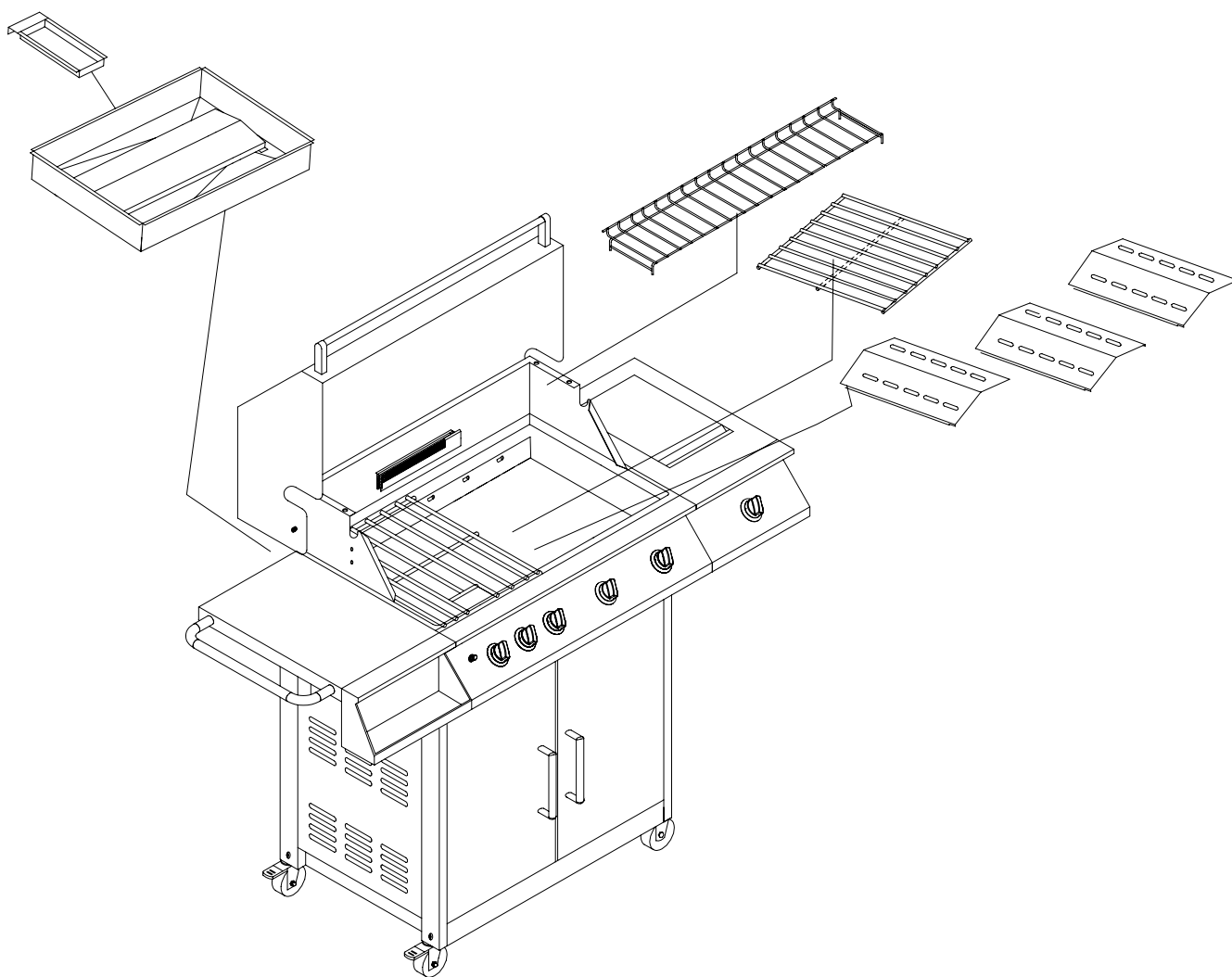

ASSEMBLY INSTRUCTIONS

STEP 16: Assemble the rotisserie kit as per the diagram below: First locate the motor bracket on left side of the bowl assembly with two “1/4 x 20 x 1/2” screws. Then place the Motor onto the motor bracket and last assemble the rotisserie as the figure shows.

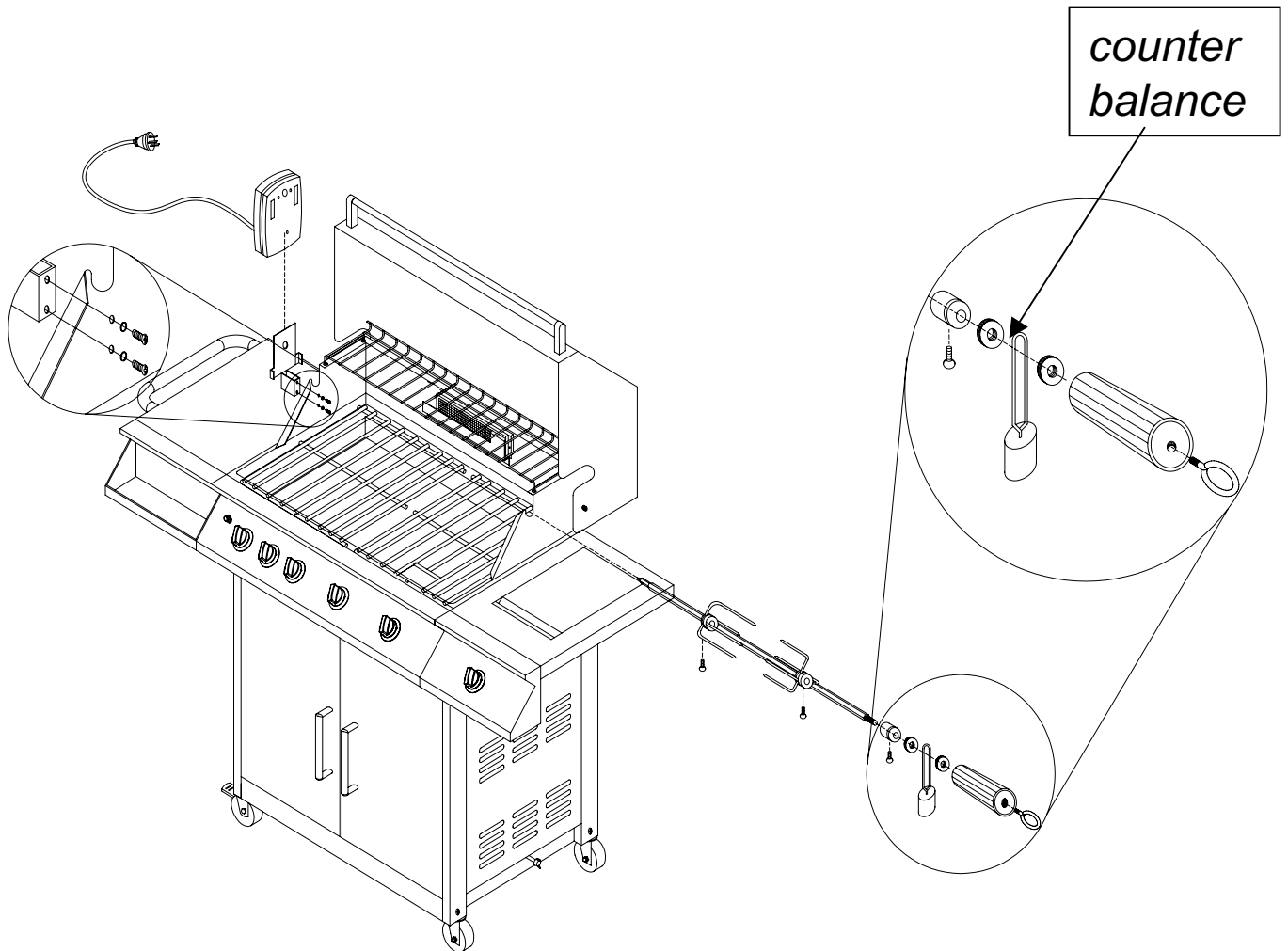

Installation of the hose onto the NG Regulator

Step1: Remove 3/8 inch adaptor



Step2: Attach the hose



Step 3: The complete assembled unit



Note: You must remove the 3/8 inch adaptor first, in order to connect with the NG regulator. If you have any questions please contact our customer service 1-800-648-5864.

GAS HOOK-UP

NEVER CONNECT AN UNREGULATED GAS SUPPLY LINE TO THE APPLIANCE. USE THE REGULATOR/HOSE ASSEMBLY SUPPLIED.

This is a Natural Gas configured grill. Do not attempt to use a Liquid Propane supply unless the grill has been reconfigured for Liquid Propane use.

Total gas consumption (per hour) of this stainless steel gas grill with all burners on “HI”:

Main burners	48,000 Btu/hr.
Side burner	12,000 Btu/hr.
Rear burner	10,000 Btu/hr.
Total	70,000 Btu/hr.

LEAK TESTING

GENERAL

Although all gas connections on the grill are leak tested at the factory prior to shipment, a complete gas tightness check must be performed at the installation site due to possible mishandling in shipment, or excessive pressure unknowingly being applied to the unit. Periodically check the whole system for leaks following the procedures listed below. If the smell of gas is detected at anytime you should immediately check the entire system for leaks.

BEFORE TESTING

Make sure that all packing material is removed from the grill.

DO NOT SMOKE WHILE LEAK TESTING.

NEVER PERFORM LEAK TEST WITH AN OPEN FLAME.

TO TEST

Make sure all control valves are in the “OFF” position. Turn the gas supply on. Check all connections including the connection to the manifold pipe assembly (the pipe that goes to the burners). Soap bubbles will appear where a leak is present. If a leak is present, immediately turn off the gas supply, tighten any leaking fittings, turn gas on, and recheck. Should the gas continue to leak from any or all of the fittings, turn off the gas supply, and contact our customer service at 1-800-648-5864.

Only those parts recommended by the manufacturer should be used on the grill. Substitution will void the warranty. Do not use the grill until all connections have been checked and do not leak.

LEAK TESTING

GAS FLOW CHECK

Each grill burner is tested and adjusted at the factory prior to shipment; however, variations in the local gas supply may make it necessary to adjust the burners. The flames of the burners should be visually checked.

Flames should be blue and stable with no yellow tips, excessive noise or lifting. If any of these conditions exist, check to see if the air shutter or burner ports are blocked by dirt, debris, spider webs, etc. If you have any questions regarding flame stability, please call customer service 1-800-648-5864.

Check all gas supply fittings for leaks before each use. It is handy to keep a spray bottle of soapy water near the shut-off valve of the gas supply line. Spray all the fittings. Bubbles indicate leaks.

INSTALLER FINAL CHECK LIST

CHECK LIST

- ✓ **Specified clearance maintained 24” from combustibles.**
- ✓ **All internal packaging removed.**
- ✓ **Knobs turn freely.**
- ✓ **Burners are tight and sitting properly on orifices.**
- ✓ **Unit tested and free of leaks.**
- ✓ **User informed of gas supply shut off valve location**

USER, PLEASE RETAIN THESE INSTRUCTIONS FOR FUTURE REFERENCE.

OPERATING INSTRUCTIONS

GENERAL USE OF THE GRILL

Each main burner is rated at 12,000 Btu/hr. The main grill burners encompass the entire cooking area and are side ported to minimize blockage from falling grease and debris. Above the burners are stainless steel radiants (flame covers). The igniter knobs are located on the lower center portion of the valve panel. Each rotary igniter is labeled on the control panel.

USING THE GRILL

Grilling requires high heat for searing and proper browning. Most foods are cooked at the "HI" heat setting for the entire cooking time. However, when grilling large pieces of meat or poultry, it may be necessary to turn

the heat to a lower setting after the initial browning. This cooks the food through without burning the outside. Foods cooked for a long time or foods basted with a sugary marinade may need a lower heat setting near the end of the cooking time.

NOTE: This stainless steel grill is designed to grill efficiently without the use of lava rocks or briquettes of any kind. Heat is radiated by the stainless steel flame tamers positioned above each burner.

NOTE: The hot grill sears the food, sealing in the juices. The longer the preheat, the faster the meat browns and the darker the grill marks.

**DO NOT LEAVE THE GRILL
UNATTENDED WHILE COOKING.**

GRILL LIGHTING INSTRUCTIONS

WARNING: IMPORTANT!

BEFORE LIGHTING...

Inspect the gas supply hose prior to turning the gas "ON". If there is evidence of cuts, wear, or abrasion, it must be replaced prior to use. Do not use the grill if the odor of gas is present. Only the pressure regulator and hose assembly supplied with the unit should be used. Never substitute regulators for those supplied with the grill. If a replacement is necessary, contact the factory for proper replacement.

TO LIGHT THE GRILL BURNER:

Always keep your face and body as far from the grill as possible when lighting.

Your stainless steel grill has a fully automatic ignition to ignite each burner. Push and turn each burner knob slowly to high, the electronic spark will repeatedly fire until the burner ignites.

GRILL LIGHTING INSTRUCTIONS

FLAME CHARACTERISTICS

Check for proper burner flame characteristics. Each burner is adjusted prior to shipment; however, variations in the local gas supply may make minor adjustments necessary.

Burner flames should be blue and stable with no yellow tips, excessive noise, or lifting. If any of these conditions exist call our customer service line. If the flame is yellow, it indicates insufficient air. If the flame is noisy and tends to lift away from the burner, it indicates too much air.

TO MATCH LIGHT THE GRILL

If the burner will not light after several attempts then the burner can be match lit.

Use of match light extension rod

Use this device to match light your burners

Simply place a lighted match between the coils on the end of the extension rod and hold next to the burner to ignite. (see reference Pg16)

If you've just attempted to light the burner with the igniter, allow 5 minutes for any accumulated gas to dissipate. Keep your face

and hands as far away from the grill as possible. Insert a lit match attached to lighting rod through the cooking

grids to the burner.(see next page) Press the control knob and rotate left to the HI setting, continue to press the knob until the burner ignites. Burner should light immediately. If the burner does not light in 4 seconds turn the knob off, wait 5 minutes and try again.

Keep a spray bottle of soapy water near the gas supply valve and check the connections before each use.

Do not attempt to light the grill if odor of gas is present. Call for service 1-800-648-5864.

LIGHTING ILLUSTRATIONS

Step 1. Make sure the Lid is open

Step 2. Push and turn one of main or side burner knobs to HI position



Step 3. You may need 3 or 4 tries to light the burner. After the burner is lit, adjust the knob as desired



TO MATCH LIGHT THE GRILL

If you've just attempted to light the burner with the igniter, allow 5 minutes for any accumulated gas to dissipate. Keep your face and hands as far away from the grill as possible. Insert a lit match (using the match holder shown in the figure) through the cooking grids to the burner. Press the control knob and rotate left to the HI setting, continue to press the knob until the burner ignites. Burner should light immediately. If the burner does not light in 4 seconds turn the knob off, wait 5 minutes and try again.

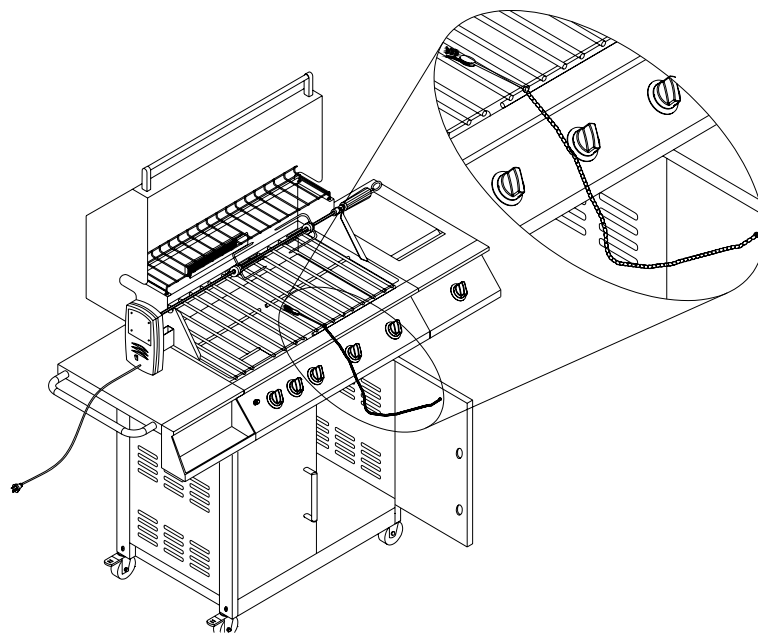

VISUAL CHECKING BURNER FLAME

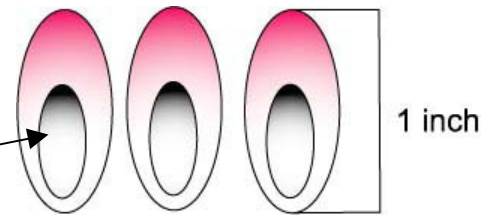
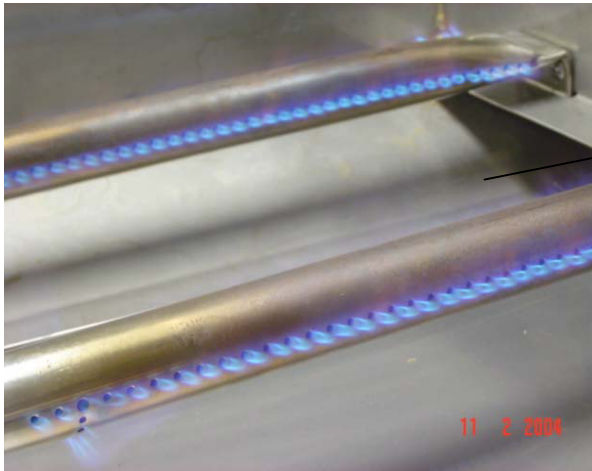

Approximate 1 1/2 " Flame Height

USING THE SIDE BURNER

WARNING: IMPORTANT!

USING THE SIDE BURNER:

Inspect the gas supply hose prior to turning the gas "ON". If there is evidence of cuts, wear or abrasion, it must be replaced prior to use. Do not use the side burner if the odor of gas is present.

WARNING: Always keep your face and body as far away from the burner as possible when lighting.

LIGHTING INSTRUCTIONS

To light the side burner, remove any cooking utensils from the burner grate. Push and turn the control knob counterclockwise to the "HI" position. If the burner does not light, turn the

USING THE SIDE BURNER

control knob to “OFF”. If the smell of gas is detected and the igniter is not functioning, immediately turn the control knob “OFF”. Allow 5 minutes for any accumulated gas to dissipate. If the side burner igniter is not functioning, see the following section for match lighting.

MATCH LIGHTING

Hold a lit extended match or lighter near the side burner ports, turn the control knob

counterclockwise to “HI”. Move your hand immediately once the burner is lit. Rotate the control knob to the desired setting.

Burner flames should be blue and stable with no yellow tips, excessive noise, or lifting. If any of these conditions exist call our customer service line. If the flame is yellow, it indicates insufficient air. If the flame is noisy and tends to lift away from the burner, it indicates too much air.

CARE AND MAINTENANCE

CARE FOR YOUR STAINLESS STEEL GRILL

The grill is made from non-rusting and non-magnetic stainless steel. There are many different stainless steel cleaners available. Always use the mildest cleaning procedure first, scrubbing in the direction of the grain. To touch up noticeable scratches in the stainless steel, sand very lightly with dry 100 grit emery paper in the direction of the grain. Specks of grease can gather on the surfaces of the stainless steel and bake on to the surface and give the appearance of rust. For removal use an abrasive pad in conjunction with a stainless steel cleaner.

GRILL RACK

The easiest way to clean the grill is immediately after cooking is completed and after turning off the flame. Wear a barbecue mitt to protect your hand from the heat and steam. Dip a brass bristle barbecue brush in tap water and scrub the hot grill. Dip the brush frequently in the bowl of water. Steam,

created as water contacts the hot grill, assists the cleaning process by softening any food particles. The food particles will fall and burn. If the grill is allowed to cool before cleaning, cleaning will be more difficult.

ENSURE THAT THE GAS SUPPLY AND THE KNOBS ARE IN THE “OFF” POSITION. MAKE SURE THE RANGETOP BURNER GRATE IS COOL BEFORE REMOVAL.

GRILL BURNERS

Extreme care should be taken when removing a burner as it must be correctly centered on the orifice when replaced before any attempt is made to relight the grill. Frequency of cleaning will depend on how often you use the grill.

MAIN GRILL BURNER CLEANING

Ensure the gas supply is off and the knobs are in the “OFF” position. Make sure the grill is cool. Clean the exterior of the burner with a wire brush. Clear stubborn scale with a metal

CARE AND MAINTENANCE

scraper. Clear any clogged ports with a straightened paper clip. Never use a wooden toothpick as it may break off and clog the port. Please note if insects or other obstructions are blocking the flow of gas through the burner, you will need to call our customer service line.

GREASE TRAY CLEANING:

The grease tray should be emptied and wiped down periodically and washed in a mild detergent and warm water solution. A small amount of sand or cat litter may be placed in bottom of grease tray to absorb the grease. Check the grease tray frequently, don't allow excess grease to accumulate and overflow out of the grease tray.

SIDE BURNER CLEANING:

Clean the exterior of the burner with a wire brush. Clear any clogged burner ports with a

straightened paper clip. Never enlarge the burner ports. Never use a wooden toothpick as it may break off the clog the port.

STAINLESS STEEL CLEANER FOR SIDE BURNER:

There are many different stainless steel cleaners available. Always use the mildest cleaning procedure first, scrubbing in the direction of the grain. Do not use steel wool as it will scratch the surface. To touch up noticeable scratches in the stainless steel, sand very lightly with dry 100 grit emery paper in the direction of the grain.

SIDE BURNER GRATE:

The top burner grate is stainless steel. To avoid burns do not clean a hot grate. They may be wiped while in place with hot, soapy water, rinsed and wiped dry. Never immerse a hot grate in water.

TROUBLE SHOOTING

SPIDER AND INSECT WARNING!!!

Spiders and insects can nest in the burners of this or any other grill, and cause the gas to flow from the front of the burner. This is a very dangerous condition which can cause a fire to occur behind the valve panel, thereby damaging the grill and making it unsafe to operate.

WHEN TO LOOK FOR SPIDERS

You should inspect the burners at least once a year or immediately after any of the following conditions occur:

1. The smell of gas in conjunction with the burner flames appearing yellow.
2. The grill does not reach temperature.
3. The grill heats unevenly.
4. The burners make popping noises.

BEFORE CALLING FOR SERVICE

If the grill does not function properly, use the following checklist before contacting your dealer for service. You may save the cost of a service call.

TROUBLE SHOOTING

CHECK LIST

PROBLEMS

Grill won't light when the control knob is rotated.

Burner flame is yellow or orange, in conjunction with the odor of gas.

Low heat with knob in "HI" position.

WHAT TO DO

Clean wire(s) and/or electrode by rubbing with alcohol and clean swab.

Wipe with dry cloth.

Make sure the wire is connected to electrode assembly.

Do other burners on the unit operate?

Check to see if other burners operate. If so, check the gas orifice on the malfunctioning burner for an obstruction.

Call our customer service line 1-800-648-5864

Is the fuel hose bent or kinked?

Is the grill in a dusty area?

Is there adequate gas supply available?

If it is only one burner that appears low, does the orifice or burner need cleaning?

Is the gas supply, or gas pressure low?

Is the grill being preheated for 15 minutes?

PARTS LIST

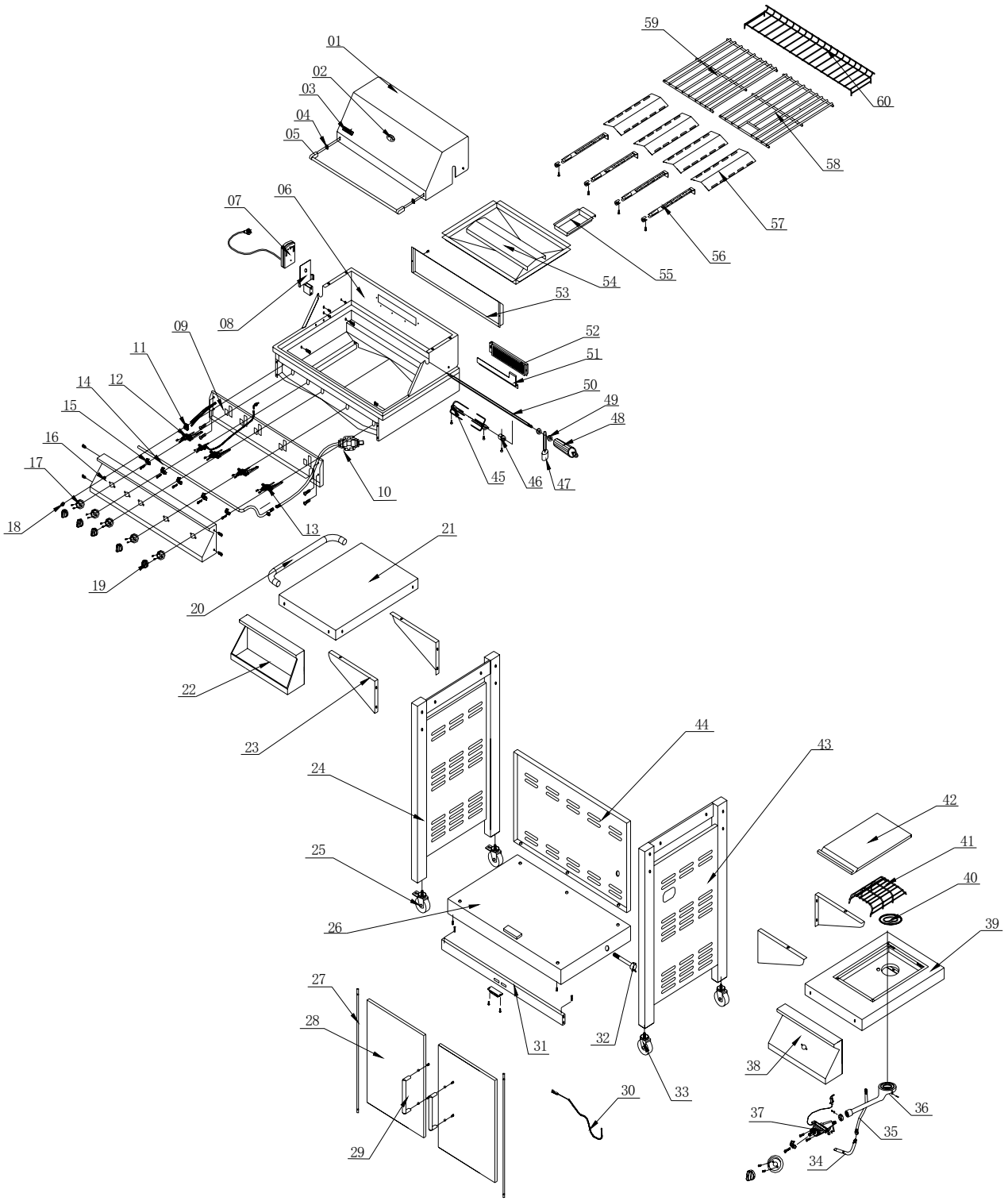

PARTS LIST

REF#	DESCRIPTION	QTY	REF#	DESCRIPTION	QTY
01	Lid, Front	1	31	Door Frame	1
02	Heat Indicator	1	32	Retention Kit	1
03	Name Plate	1	33	3''Caster	2
04	Heater Insulating Spacer	2	34	Gas Hose Connector	1
05	Handle Assembly, Lid	1	35	Electronic Ignition	1
06	Inner Lid	1	36	Pipe Type, Side Burner	1
07	Rotisserie Motor	1	37	Gas Valve, Side Burner	1
08	Motor Bracket	1	38	Control Panel, Side Burner	1
09	Front Baffle	1	39	Bowl Assembly, Side Burner	1
10	Regulator NG	1	40	Side Burner Ring	1
11	Electronic Ignition	1	41	Cooking Grid, Side Burner	1
12	Gas Valve, Main burner	4	42	Lid, Side Burner	1
13	Gas Valve, Infrared burner	1	43	Side Panel, Right	1
14	Valve Manifold	1	44	Rear Panel	1
15	Manifold Retainer Bracket	5	45	Spit Fork	2
16	Control Panel, Main Burner	1	46	Shelf Collar	1
17	Control Knob Seat	6	47	Counter Balance	1
18	Electronic Ignition Button	1	48	Rotisserie Handle	1
19	Control Knob	6	49	Key Washer	2
20	Push Bar	1	50	Spit Rod	1
21	Side Shelf, Left	1	51	Gas Collector, Rear Burner	1
22	Spice Tray	1	52	Rear Burner	1
23	Side Shelf Bracket	4	53	Rear Barrel, Rear Burner	1
24	Side Panel, Left	1	54	Big Grease Tray	1
25	3''Caster with Break	2	55	Small Grease Tray	1
26	Bottom Panel	1	56	Main Burner	4
27	Door Hinge	2	57	Flame Tamer	4
28	Door Assembly	2	58	Cooking Grid With Hole	1
29	Handle, Front Door	2	59	Cooking Grid	1
30	Lighting Rod	1	60	Warming Rack	1

ORDERING PARTS

HOW TO ORDER REPLACEMENT PARTS

To make sure you obtain the correct replacement part(s) for your gas grill, please refer to the parts list on this page. The following information is required to assure getting the correct part.

- Gas grills model number (see data sticker on grill).
- Part number of replacement part needed.
- Description of replacement part needed.
- Quantity of parts needed.

To obtain replacement parts, contact

Nexgrill Industries, Inc. customer service
1-800-648-5864.

IMPORTANT

Use only factory authorized parts. The use of any part that is not factory authorized can be dangerous. This will also void your warranty.

Keep this assembly and operating instruction manual for convenient referral, and for replacement parts ordering.

CAUTION

Gas valves are pre-sent at the factory (valve assembly will be marked accordingly). If you wish to convert at some later date, be sure to contact your gas supplier or grill dealer before making the conversion.

Different orifices must be installed when converting from one type of gas to another. You will also need a data plate indicating what type of gas is used by the grill.

GRILL HINTS

The doneness of meat, whether rare, medium, or well done, is affected to a large degree by the thickness of the cut. Expert chefs say it is impossible to have a rare doneness with a thin cut of meat.

The cooking time is affected by the kind of meat, the size and shape of the cut, the temperature of the meat when cooking begins, and the degree of doneness desired.

When defrosting meats it is recommended that it be done overnight in the refrigerator as opposed to a microwave. This in general yields a juicier cut of meat.

Use a spatula instead of tongs or a fork to turn

the meat, as a spatula will not puncture the meat and let the juices run out.

To get the juiciest meats, add seasoning or salt after the cooking is finished on each side and turn the meat only once (juices are lost when the meat is turned several times). Turn the meat just after the juices begin to bubble to the surface.

Trim any excess fat from the meat before cooking. To prevent steaks or chops from curling during cooking, slit the fat around the edges at 2-inch intervals.

DO NOT LEAVE THE GRILL UNATTENDED WHILE COOKING.

GRILL COOKING CHART

FOOD	WEIGHT OR THICKNESS	FLAME SIZE	APPROXIMATE TIME	SPECIAL INSTRUCTIONS AND TIPS
VEGETABLES				
Fresh				Slice. Dot with butter or margarine. Wrap in heavy-duty foil. Grill, turning occasionally.
Beets		Medium	12 to 20 minutes	
Carrots				
Turnips				Grill, turning once. Brush occasionally with melted butter or margarine.
Onion	1/2 inch slices	Medium	8 to 20 minutes	
Potatoes				Wrap individually in heavy-duty foil. Grill, rotating occasionally.
Sweet	Whole	Medium	40 to 60 minutes	
White	6 to 8 ounces	High	45 to 60 minutes	
Frozen				Dot with butte or margarine. Wrap in heavy-duty foil. Grill, turning occasionally.
Asparagus		Medium	15 to 30 minutes	
Broccoli				
Brussels Sprouts				
Green beans				
Peas				
French fries		Medium	15 to 30 minutes	Place in aluminum foil pan. Grill, stirring occasionally.
Meats				
Beef				
Hamburgers	1/2 to 3/4 inch	Medium	10 to 18 minutes	Grill, turning once when juices rise to the surface. Do not leave hamburgers unattended since a flare-up could occur quickly.
		High	8 to 15 minutes	
Steaks				
Rib eye,				

GRILL COOKING CHART

FOOD	WEIGHT OR THICKNESS	FLAME SIZE	APPROXIMATE TIME	SPECIAL INSTRUCTIONS AND TIPS
Tenderloin, Porterhouse, T-Bone, Sirloin				
Rare	1 inch	High	8 to 14 minutes	Remove excess fat from edge. Slash remaining fat at 2-inch intervals. Grill, turning once.
	1-1/2 inch	High	11 to 18 minutes	
Medium	1 inch	Medium to	12 to 22 minutes	
	1-1/2 inch	High	16 to 27 minutes	
Well-done	1 inch	Medium	18 to 30 minutes	
	1-1/2 inches	Medium	16 to 35 minutes	
Lamb Chops & Steaks				
Rare	1 inch	High	10 to 15 minutes	Remove excess fat from edge. Slash remaining fat at 2-inch intervals. Grill, turning once.
	1-1/2 inch	High	14 to 18 minutes	
Medium	1 inch	Medium to	13 to 20 minutes	
	1-1/2 inch	High	18 to 25 minutes	
Well-done	1 inch	Medium	17 to 30 minutes	
Pork				
Chops	1 inch	Medium	20 to 30 minutes	Remove excess fat from edge. Slash remaining fat at 2-inch intervals. Grill, turning once.
Well-done	1-1/2 inches	Medium	30 to 40 minutes	
Ribs		Medium	30 to 40 minutes	Grill, turning occasionally. During last few minutes brush with barbecue sauce, turn several times.
Pork Ham steaks				
(precooked)	1/2 inch slices	High	4 to 8 minutes	Remove excess fat from edge. Slash remaining fat at 2-inch intervals. Grill, turning once.
Hot dogs		Medium	5 to 10 minutes	
POULTRY				
Broiler/fryer	2 to 3 pounds	Low or	1 to 1-1/2 hours	Place skin side up. Grill, turning and brushing frequently with melted butter, margarine, oil or marinade.
Halved or Quartered well-done		Medium	40 to 60 minutes	
Breasts well-done		Medium	30 to 45 minutes	

GRILL COOKING CHART

FOOD	WEIGHT OR THICKNESS	FLAME SIZE	APPROXIMATE TIME	SPECIAL INSTRUCTIONS AND TIPS
FISH AND SEAFOOD				
Steaks				Grill, turning once. Brush with melted butter, margarine or oil to keep moist.
Halibut	3/4 to 1 inch	Medium to	8 to 15 minutes	
Salmon		High		
Swordfish				
Whole				
Catfish	4 to 8 ounces	Medium to	12 to 20 minutes	Grill, turning once. Brush with melted butter, margarine or oil.
Rainbow trout		High		

GRILL RECIPE SUGGESTIONS

BBQ SALMON

2 large salmon steaks
2 tbs. Oil
Salt & pepper
2 oz. thin bacon slices
2 tbs. Butter
1 tbs. Lemon juice
Sprig of parsley
Lemon wedges

Preheat the BBQ.

Brush the steaks with oil and season with salt and pepper. Place on BBQ grill and cook for 10 minutes, turning steaks over halfway through cooking time.

Meanwhile fry the bacon in a pan on the side burner. Drain on paper towels. Melt the butter in a small saucepan taking care not to discolor it. Arrange the fish and bacon on serving plates. Pour the butter over and sprinkle with lemon juice. Garnish with parsley sprig and lemon wedges. Serve with boiled potatoes tossed in butter and sprinkled with chopped parsley and serve with a crisp lettuce salad.

Note: Substitute catfish, halibut or cod for salmon.

BAKED CHILI CORN

6 medium ears corn, husked
3 tbs. Butter or margarine, melted
Dash ground cumin
Dash ground coriander

About ½ hour before cooking, turn the butter on for grill. Place each cob on a heavy-duty foil. In a bowl, combine remaining ingredients. Mix well. Brush 1-1/2 tsp. Butter mixture over each ear. Close foil and fold up ends to seal. Place on grill. Cook, turning packets occasionally 10 to 12 minutes or until cooked through.

TANGY SEAFOOD KABOBS

1 lb. Large shrimp, shelled & deveined
¾ lbs. sea scallops
2/3 c. chili sauce
¼ c. cider vinegar
3 tbs. chopped parsley
1 tbs. vegetable oil
1 tbs. Worcestershire sauce
½ tsp. prepared horseradish
1 cove garlic, minced
1 20 oz. Can pineapple chunks in juice, drained
In medium bowl, combine shrimp and scallops. In small bowl combine chili sauce and next six ingredients. Pour over seafood. Toss to coat. Cover, refrigerate 2 hours.

Half hour before cooking, turn the grill burner on full. Drain seafood reserving marinade. On each of twelve 10" skewers, thread 2 shrimps and 2 scallops, alternating with pineapple chunks. Place skewers on grill. Cook 7-10 minutes, basting and turning often

Butter and sprinkle with chopped parsley and serve with a crisp lettuce salad.

Note: Substitute catfish, halibut or cod for salmon.

PORK CHOPS

4 Pork chops
Marinade
1 large onion
2 tbs. lemon juice or vinegar
2 tbs. oil
½ tsp. powdered mustard
2 tsp. Worcestershire sauce
½ tsp. freshly ground black pepper
1 tsp. sugar
½ tsp. paprika
1 clove garlic

Peel and grate onion. Add rest of the ingredients except the pork chops. Mix well. Pour over chops and marinate one hour in a cool place. Turn the BBQ grill on full. Heat 10 minutes. BBQ the chops brushing with the marinade occasionally. Serve with mixed salad, dressed with vinaigrette flavored with fresh dill.

BARBECUED LONDON BROIL

4 to 6 servings
¾ c. Italian dressing
1 tsp. Worcestershire sauce
1 tsp. dry mustard
¼ tsp. thyme, crushed
1 medium onion, sliced
1 pound flank steak, scored
2 tbs. butter, melted

Combine first 4 ingredients, add onion and marinate flank steak with it. Refrigerate at least 4 hours or overnight. Remove steaks and grill on your preheated BBQ grill. Grill 5 to 7 minutes on each side basting frequently with the marinade. In the meantime sauté onions from the marinade in butter in a skillet on your side burner for 3 minutes. To serve, slice steak diagonally into thin slices, sprinkle onions over top. Garnish with vegetable kabobs.

BARBECUED POTATOES and CHEESE

1-1/2 cups shredded cheddar cheese
1 can (10-3/4 oz.) condensed cream of mushroom soup
1/3 cup milk
2 tbs. barbecue sauce
¼ tsp. oregano
¼ tsp. salt
1/8 tsp. pepper
4 cups thinly sliced potatoes (4 medium-sized potatoes)

GRILL RECIPE SUGGESTIONS

Preheat grill. Combine cheese, condensed soup, milk, BBQ sauce, oregano, salt and pepper in a large mixing bowl. Stir in potatoes until well coated. Turn into well buttered 1-1/2 quart rectangular baking dish. Cover dish with aluminum foil. Bake covered 25 minutes on medium with the lid of your BBQ closed. Remove foil and continue baking 15 minutes longer or until potatoes are tender. Let stand 5 minutes before serving.

VEGETABLE KABOBS

3 medium-sized zucchini
12 cherry tomatoes
12 fresh mushrooms
Grated Parmesan cheese

Parboil whole zucchini 5 minutes on your side burner or until just tender. Drain and cut into 1/2 inch slices. Thread zucchini, tomatoes and mushrooms alternately on each of six skewers. Brush with marinade made of Italian dressing, Worcestershire sauce, mustard and thyme. Grill 5 to 7 minutes turning and basting occasionally. Sprinkle liberally with Parmesan cheese.

FAJITAS

1-1/2 lb. flank steak or boneless chicken breasts
2 tbs. oil
1/2 cup lime juice
1/2 tsp. salt
1/2 tsp. celery salt
1/4 tsp. garlic powder
1/2 tsp. pepper
1/4 tsp. oregano
1/4 tsp. cumin
Flour tortillas lemon

Pound flank steak to 1/4 inch thickness or flatten chicken breasts. Mix oil, lime juice and seasonings in a zip lock bag. Add meat and shake bag to coat the meat. Refrigerate overnight or at least 6 to 8 hours. Wrap tortillas in foil. Remove meat from marinade. Cook on a preheated gas grill for 5 to 8 minutes on each side. While meat is cooking, heat tortillas on grill. Slice meat across grain in thin slices. Place on hot platter. Squeeze lemon juice over. Wrap meat and any of the following toppings in tortillas: chopped tomatoes, guacamole, sour cream, taco salsa.

BEEF AND LAMB KABOBS

Serve 4

1/2 lb. boneless sirloin or beef cut into 1" cubes
1/2 lb. boneless loin of lamb cut into 1" cubes
2/3 c. water, divided in half
1/4 c. chopped onion
2 tbs. soy sauce
1/4 c. vegetable oil, divided
1 tbs. dark brown sugar
1 tbs. fresh lemon juice
2 cloves garlic, minced
1/4 tsp. ground cumin
1/4 tsp. ground coriander
1/4 tsp. ground turmeric
1/8 tsp. ground red pepper
1/8 tsp. ground ginger
1 red pepper cut into chunks
1 large banana, cut into chunks
8 small mushrooms
1/3 c. smooth peanut butter

In blender, process 1/3 c. water, onion, soy sauce, 2 tsp. oil and the next 8 ingredients until smooth. Pour over meat cubes and marinate about 4 hours, turning occasionally. Drain and reserve marinade. Onto to four 12" skewers alternately thread meat, pepper, banana and mushrooms. Preheat grill. Brush the kabobs with oil. Grill 7-8 minutes each side.

Bring marinade to boil on the side burner in a saucepan. Add remaining 1/3 c. water and peanut butter. Stir to blend. Heat through. If sauce gets too thick, add 1 tbs. water. Serve sauce with kabobs.

EGGPLANT CAVIAR

1 large eggplant
2 tbs. olive oil
2 tbs. wine vinegar
2 tbs. finely chopped onion
1/2 clove garlic, minced
1 medium tomato, chopped salt and pepper
Roast eggplant on gas grill over medium flame, turning occasionally until thoroughly cooked. This may take 30 minutes. Remove from grill and cool for handling. Strip off the skin and chop eggplant finely. Add all the seasonings. Chill thoroughly and serve on toast.

GRILL RECIPE SUGGESTIONS

CHICKEN TANDOORI STYLE

8 large chicken thighs or drumsticks
1 c. plain nonfat yogurt
½ c. lemon juice
2 tsp. salt
½ tsp. Cayenne pepper
½ tsp. black pepper
½ tsp. crushed garlic
½ tsp. grated ginger
1 tbs. corn oil

Combine all the ingredients in a large mixing bowl and marinate the chicken for 8 hours in the refrigerator. Drain the chicken and spread on the spit running the rod on the fleshier side of the bone.

Rotis using the rotis burner. Cook on medium high heat for 40 minutes basting occasionally with the remainder of the marinade mixture. Serve with sliced onions and lemon wedges.

SPARE RIBS

Marinade:

1 c. soy sauce
½ c. honey
½ c. vinegar
½ c. dry sherry
2 tsp. chopped garlic
2 tsp. sugar
1 c. water
1 chicken bouillon cube
1 can beer for basting sauce

Marinate ribs for 3 hours. Use marinade for basting by adding beer to it. Place pan under the ribs and baste frequently. To cook ribs select lean, meaty ribs and accordion pleat them with your spit. Slide four prong meat hook down the length of spit and tighten. At the beginning of

the rack and to its center, penetrate the second rib with the pointed end of the spit and push it between the meat. Skip a couple and continue the process until the entire rack is accordion pleated. Fasten the second meat hook into the rack. Turn your rotis burner on high. Rotis for 50 minutes or until done.

PORK ROAST

Apple cider vinegar basting sauce:

1 c. apple cider vinegar
6 oz. water
½ stick butter
Salt, pepper, parsley and garlic for seasoning
2 oz. lemon juice
10 lbs. pork roast

Time: 1-1/2 hours to 2 hours

Bring pork to room temperature before placing it on the spit rod. Place on the rod and test for balance. Light rotis burner. Turn control knob to high. Use the above basting sauce for rotissing.

TURKEY

12 lb. turkey
Beer basting sauce:
1 can beer
12 oz. water
1 stick butter
1 tsp. salt
1 tsp. pepper
½ tsp. garlic flakes
1 tsp. parsley

Thaw the bird completely. Wash inside out. Securely tie the legs and wings. Light rotis burner. Turn to high. Combine all the ingredients for basting sauce in a shallow pan. Place it under the turkey 15 to 20

minutes. Cook for approximately 3 hours. The basting sauce combined with turkey drippings makes a delicious gravy.

LIMITED WARRANTY

LIMITED WARRANTY

MODEL 720-0133-NG

STAINLESS STEEL OUTDOOR GAS GRILL

Nexgrill Industries, Inc. warrants to the original consumer purchaser of each Outdoor Gas Grill that when subject to normal residential use, it is free from defects in workmanship and materials for the periods specified below. This warranty excludes grills used in rental or commercial applications. There will be a shipping and handling charge for the delivery of the warranty part(s).

<u>Component</u>	<u>Warranty Period</u>
Burners:	5 Years
Stainless Steel Flame Tamer:	3 Years
Cooking Grids:	3 Years
Valves:	1 Year
Frame, Housing, Cart, Control Panel, Igniter, and Related Parts:	1 Year
All Stainless Steel Parts	3 Years

Our obligation under this warranty is limited to repair or replacement, at our option, of the product during the warranty period. The extent of any liability of Nexgrill Industries, Inc. under this warranty is limited to repair or replacement. This warranty does not cover normal wear of parts, damage resulting from any of the following: negligent use or misuse of the product, use on improper fuel/gas supply, use contrary to operating instructions, or alteration by any person other than our factory service center. The warranty period is not extended by such repair or replacement.

Warranty claim procedure: If you require service or parts for your grill, please contact our Warranty Service Center for factory direct assistance. Our hours of operation are 8 AM to 5 PM EST. Our number is 1-800-648-5864 and our FAX number is 1-905-671-4604. Please direct all correspondence to: Target Wholesale and Distributors Inc. 1075 Britannia Road East Mississauga, Ontario Canada L4W 3X1.

Product repair as provided under this warranty is your exclusive remedy. Nexgrill Industries, Inc. shall not be liable for any incidental or consequential damages for breach of any express or implied warranty on its products. Except to the extent prohibited by applicable law, any implied warranty or merchantability or fitness for a particular purpose on this product to the duration of the above warranty. Some states do not allow the exclusion or limitation of incidental or consequential damages, or allow limitations on how long an implied warranty lasts, so the above limitations or exclusions may not apply to you. This warranty gives you specific legal rights, and you may have other rights, which vary from state to state.

