

This Owner's Manual is provided and hosted by [Appliance Factory Parts](http://ApplianceFactoryParts.com).

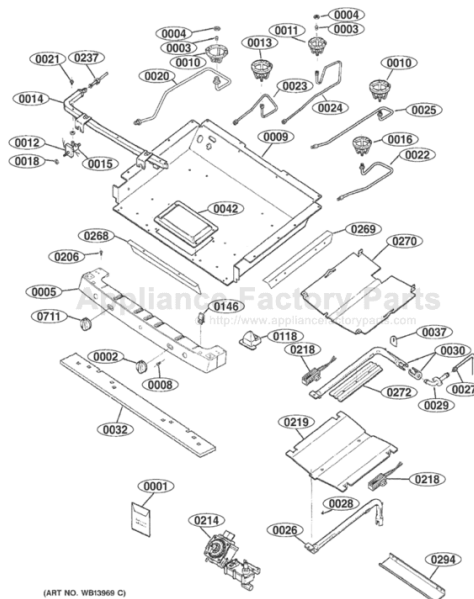

LG LRG30855ST Owner's Manual

[Shop genuine replacement parts for LG LRG30855ST](#)



11/08

[Find Your LG Gas Range Parts - Select From 55 Models](#)

----- Manual continues below -----



LG

SEALED BURNER 30" GAS RANGE

TECHNICAL SERVICE GUIDE

LRG30855ST

LRG30355ST/SB/SW

LRG30357ST/SB/SW

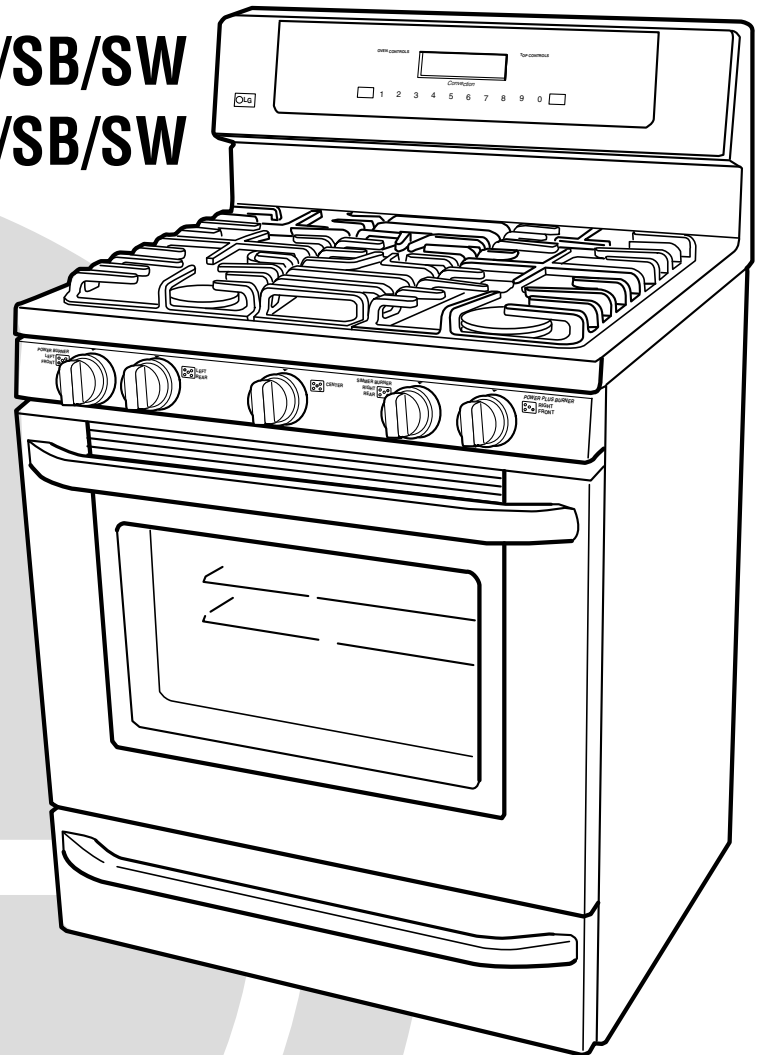



IMPORTANT SAFETY NOTICE

The information in this service guide is intended for use by individuals possessing adequate backgrounds of electrical, electronic, and mechanical experience. Any attempt to repair a major appliance may result in personal injury and property damage. The manufacturer or seller cannot be responsible for the interpretation of this information, nor can it assume any liability in connection with its use.

WARNING

If the information in this manual is not followed exactly, a fire or explosion may result causing property damage, personal injury or death. If you smell gas:

- Do not try to light any appliance.
- Do not touch any electrical switch; do not use any phone in the building.
- Immediately call the gas supplier from a neighbor's phone. Follow the gas supplier's instructions.
- If you cannot reach the gas supplier, call the fire department.

WARNING

To avoid personal injury, disconnect power before servicing this product. If electrical power is required for diagnosis or test purposes, disconnect the power immediately after performing the necessary checks.

RECONNECT ALL GROUNDING DEVICES

If grounding wires, screws, straps, clips, nuts, or washers used to complete a path to ground are removed for service, they must be returned to their original position and properly fastened.

LG Electronics U.S.A., Inc.

Technical Service Guide

Copyright © 2006

All rights reserved. This service guide may not be reproduced in whole or in part in any form without written permission from LG Electronics U.S.A., Inc..

Table of Contents

Bake and Broil Burner Flame Adjustments.....	32
Bake Burner and Glow-bar Igniter.....	31
Broil Burner and Glow-bar Igniter	30
Component Locator Views.....□	20
Control Panel	37
Control Panel and Touch Board.□	38
Control Panel Assembly.....□	37
Control Features.....□	7
Convection Fan Motor	34
Door Assemblies.....□	27
Door Latch Assembly.....□	43
Electronic Range Control (ERC)...□	38
Failure Codes and Component Testing	49
Gas Manifold	42
Gas Shut-off Valve.....□	24
Glow-bar Igniter	29
Ignitor Switches.....□	42
Installation Requirements.....□	5
Introduction.....□	4
Lock Motor and Door Latch Switch Circuit Information	46
Maintop Burner Assembly.....□	39
Maintop Burner Valves.....□	41
Maintop Removal.....□	25
Manifold Panel	41
Meat Probe Outlet	35
Nomenclature	4
Oven Burner Ignition System□	29
Oven Calibration	46
Oven Components and Replacement.....	29
Oven Door Hinge Removal.....□	26
Oven Door Removal.....□	23
Oven Door Switch.....□	28
Oven Light Bulb	28
Oven Temperature Sensor	35
Range Components and Replacement	23
Range Removal.....□	23
Range Top Components and Replacement	39
Safety Valve and Pressure Regulator.....	36
Schematics and Wiring Diagrams.....	57
Service Test Mode.....□	48
Side Panel Removal	25
Spark Module.....□	37
Warming Drawer Removal.....□	23
Warranty	6

Introduction

- The new gas range has an electronic tactile touch-control panel for the oven. This easy-to-operate touch-control panel is user friendly and simple to understand.
- The range includes many helpful features including a self-cleaning oven.
- The convection baking and roasting feature provides even cooking and superior baking every time.
- New servicing features include front accessibility to most components and easy replacement access to the oven door locking assembly.
- All models are available in natural gas and are supplied with an LP regulator conversion feature and LP orifice spuds for the surface burners.
- The information on the following pages will help you service these new all gas ranges effectively and efficiently.

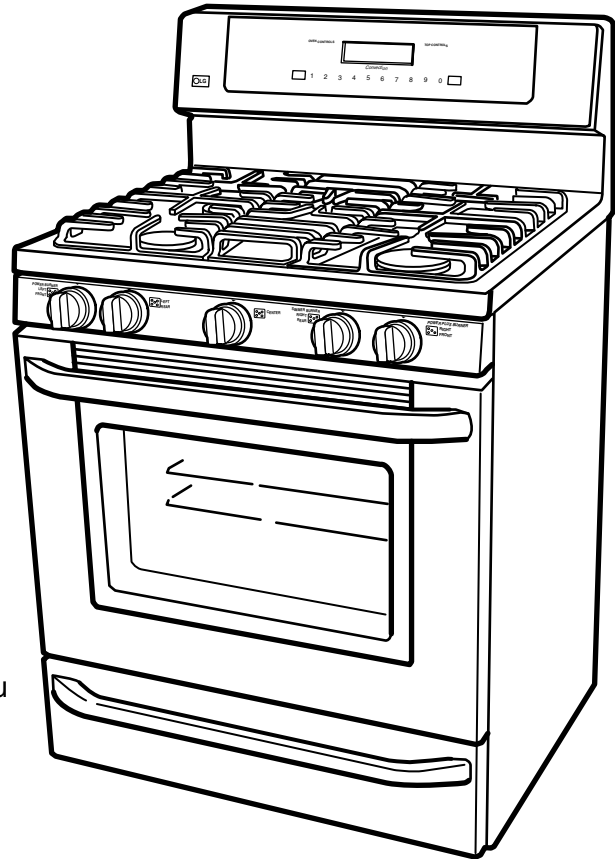

Nomenclature

The nomenclature plate of this range is located on the oven frame above the warming drawer.

In addition to the model and serial numbers, this plate shows the ratings of the burners, and the type of fuel and pressure the cooktop was adjusted for when it left the factory.

The mini-manual is placed in an envelope located behind the backguard.

An LP (Propane) gas conversion instructions sheet is attached to the back side of the range.

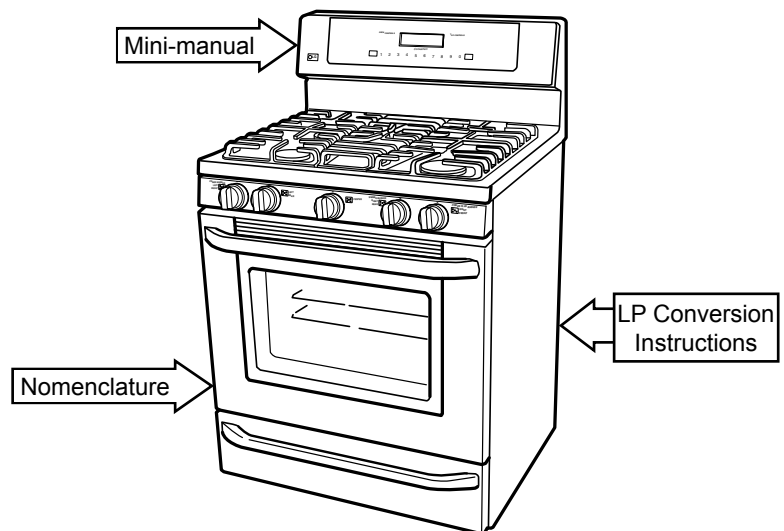

Installation Requirements

Installation information is for reference only. See the Installation Instructions shipped with the product for complete details and before attempting to install the range.

Power Supply

This appliance must be supplied with proper voltage and frequency, connected to an individually grounded branch circuit, and protected by a circuit breaker or time delay fuse as noted on rating plate.

Wiring must conform to the National Electrical Codes.

Grounding Specifications

Ground Path Resistance	0.10W	Max.
Insulation Resistance	250KW	Min.

Gas Supply

Your range is designed to operate at a pressure of 5" of water column on natural gas or, if designed for LP gas (propane or butane), 10" of water column.

Make sure you are supplying your range with the type of gas for which it is designed.

This range is convertible for use on natural or propane gas. If you decide to use this range on LP gas, conversion must be made by a qualified LP installer before attempting to operate the range on that gas.

For proper operation, the pressure of natural gas supplied to the regulator must be between 5" and 13" of water column. For LP gas, the pressure supplied must be between 10" and 13" of water column.

When checking for proper operation of the regulator, the inlet pressure must be at least 1" greater than the operating (manifold) pressure as given above.

The pressure regulator located at the inlet of the range manifold must remain in the supply line regardless of whether natural or LP gas is being used.

A flexible metal appliance connector used to connect the range to the gas supply line should have an I.D. of 1/2" and be 5 feet in length for ease of installation. In Canada, flexible connectors must be single wall metal connectors no longer than 6 feet in length.

Minimum Clearances

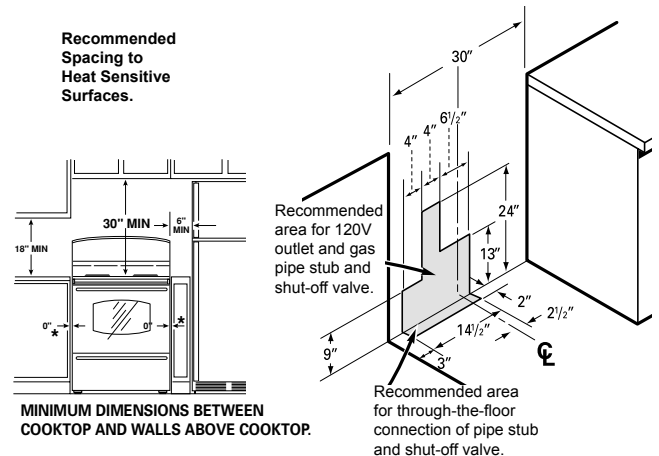

Anti-Tip Device

WARNING: All ranges can tip causing injury. Install anti-tip device packed with range. The anti-tip device should be attached to the wall.

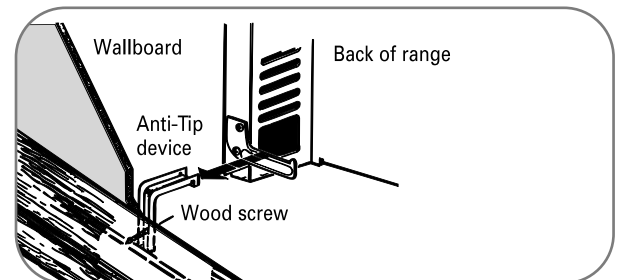
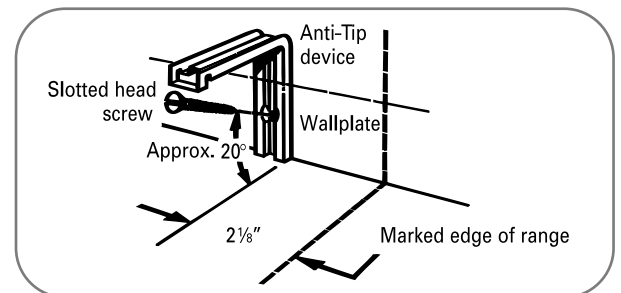

Check for proper operation by carefully tipping the range forward.

Warranty

LG Electronics Inc. will repair or replace your product, at LG's option, if it proves to be defective in material or workmanship under normal use, during the warranty period set forth below, effective from the date of original consumer purchase of the product. This limited warranty is good only to the original purchaser of the product and effective only when used in U.S.A.

WARRANTY PERIOD:	HOW SERVICE IS HANDLED:
One Year From the date of the original purchase	Any part of the range which fails due to a defect in materials or workmanship. During this full one-year warranty , LG will also provide, free of charge , all labor and in-home service to replace the defective part.

THIS WARRANTY IS IN LIEU OF ANY OTHER WARRANTIES, EXPRESS OR IMPLIED, INCLUDING WITHOUT LIMITATION, ANY WARRANTY OF MERCHANTABILITY OR FITNESS FOR A PARTICULAR PURPOSE. TO THE EXTENT ANY IMPLIED WARRANTY IS REQUIRED BY LAW, IT IS LIMITED IN DURATION TO THE EXPRESS WARRANTY PERIOD ABOVE. LG WILL NOT BE LIABLE FOR ANY CONSEQUENTIAL, INDIRECT, OR INCIDENTAL DAMAGES OF ANY KIND, INCLUDING LOST REVENUES OR PROFITS, IN CONNECTION WITH THE PRODUCT. SOME STATES DO NOT ALLOW LIMITATION ON HOW LONG AN IMPLIED WARRANTY LASTS OR THE EXCLUSION OF INCIDENTAL OR CONSEQUENTIAL DAMAGES, SO THE ABOVE LIMITATIONS OR EXCLUSIONS MAY NOT APPLY TO YOU.

THIS LIMITED WARRANTY DOES NOT APPLY TO:

1. Service calls to correct the installation of your appliance, to instruct you how to use your appliance, to replace house fuses or correct house wiring, or to replace owner-accessible light bulbs.
2. Repairs when your appliance is used in other than normal, single-family household use.
3. Pickup and delivery. Your appliance is designed to be repairable in the home.
4. Damage resulting from accident, alteration, misuse, abuse, fire, flood, improper installation, acts of God, or use of products not approved by LG Corporation.
5. Repairs to parts or systems resulting from unauthorized modifications made to the appliance.
6. Replacement parts or repair labor costs for units operated outside the united states.
7. Any labor costs during the limited warranty period.

This warranty is extended to the original purchaser and any subsequent owner for products purchased for home use within the USA. In Alaska, the warranty excludes the cost of shipping or service calls to your home. Some states do not allow the exclusion or limitation of incidental or consequential damages, so this exclusion or limitation may not apply to you. This warranty gives you specific legal rights, and you may also have other rights which vary from states to states. To know what your legal rights are, consult your local or state consumer affairs or your state's Attorney General.

CUSTOMER ASSISTANCE INFORMATION:

To Prove Warranty Coverage	Retain your Sales Receipt to prove date of purchase. A copy of your Sales Receipt must be submitted at the time warranty service is provided.
To Obtain Nearest Authorized Service Center or Sales Dealer, or to Obtain Product, Customer, or Service Assistance	Call 1-800-243-0000 (Phone answered 24 hours - 365 days a year) and choose the appropriate prompt from the menu; or visit our website at: http://us.lgservice.com .

Control Features

Features and appearance may vary between models.

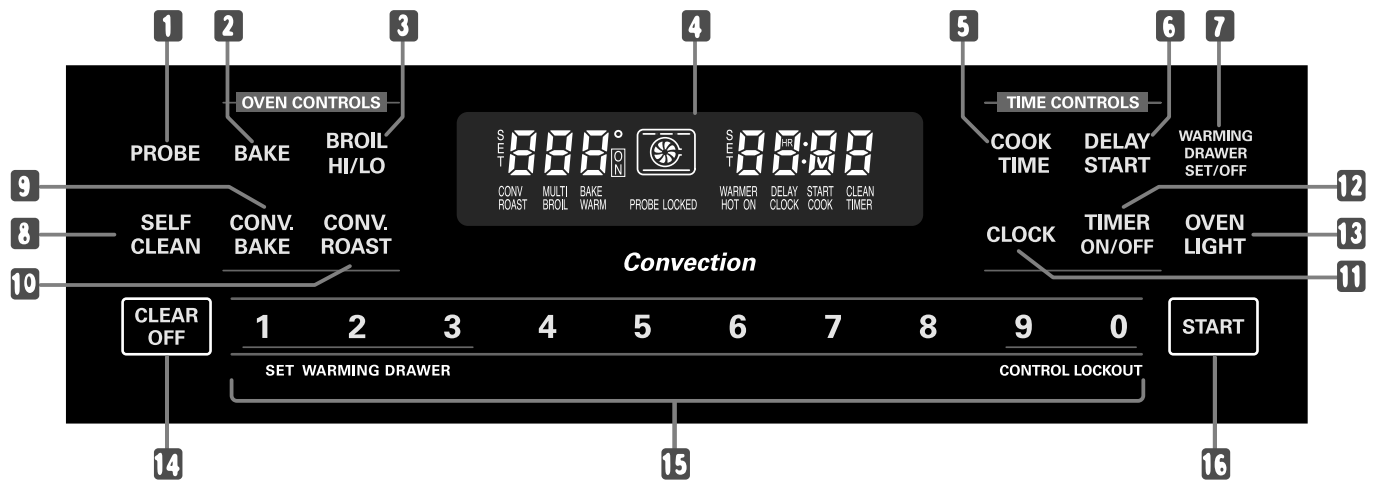

Convection Models - Oven Control, Clock and Timer Features

1. **PROBE PAD:** Touch this pad to select the probe function.
 2. **BAKE PAD:** Touch this pad to select the bake function.
 3. **BROIL HI/LO PAD:** Touch this pad to select the broil function.
 4. **DISPLAY:** Shows the time of day, oven temperature, whether the oven is in the bake, broil or self-cleaning mode and the times set for the timer or automatic oven operations, convection bake it will also show warming drawer settings.
- Note:** If “F– and a number or letter” flash in the display and the oven control signals, this indicates a function error code.
- If your oven was set for a timed oven operation and a power outage occurred, the clock and all programmed functions must be reset.
- The time of day will flash in the display when there has been a power outage. Reset the clock.
- If “Err” appears in the display, you have tried to set a time or temperature outside of the control’s limits. Touch CLEAR/OFF pad and enter a new setting.
- Touch the CLEAR/OFF pad. Allow oven to cool for one hour. Put oven back into operation. If function error code repeats, disconnect power to range and call for service.
5. **COOK TIME PAD:** Touch this pad and then touch the number pads to set the amount of time you want your food to cook. The oven will shut off when the cooking time has run out.
 6. **DELAY START PAD:** Use along with COOK TIME or SELF CLEAN pads to set the oven to start and stop automatically at a time you set.
 7. **WARMING DRAWER PAD:** Touch this pad and then touch number pads 1–3 to use the warming drawer. See the Using the electric warming drawer section.
 8. **SELF CLEAN PAD:** Touch this pad to select self-cleaning function. See the Using the self-cleaning oven section.
 9. **CONVECTION BAKE PAD:** Press to select baking with the convection function.
 10. **CONVECTION ROAST PAD:** Press to select roasting with the convection function.
 11. **CLOCK PAD:** Press before setting the time of day.
 12. **TIMER ON/OFF PAD:** Press to select the timer feature.
 13. **OVEN LIGHT PAD:** Touch this pad to turn the oven light on or off.
 14. **CLEAR/OFF PAD:** Touch this pad to cancel ALL oven operations except the clock, timer and warming drawer settings.
 15. **NUMBER PADS:** Use to set any function requiring numbers such as time of day on the clock, timer, oven temperature, internal food temperature, start time and length of operation for timed baking and self-cleaning.
 16. **START PAD:** Must be touched to start any cooking or cleaning function, and warming drawer settings.

(Continued next page)

Features and appearance may vary between models.

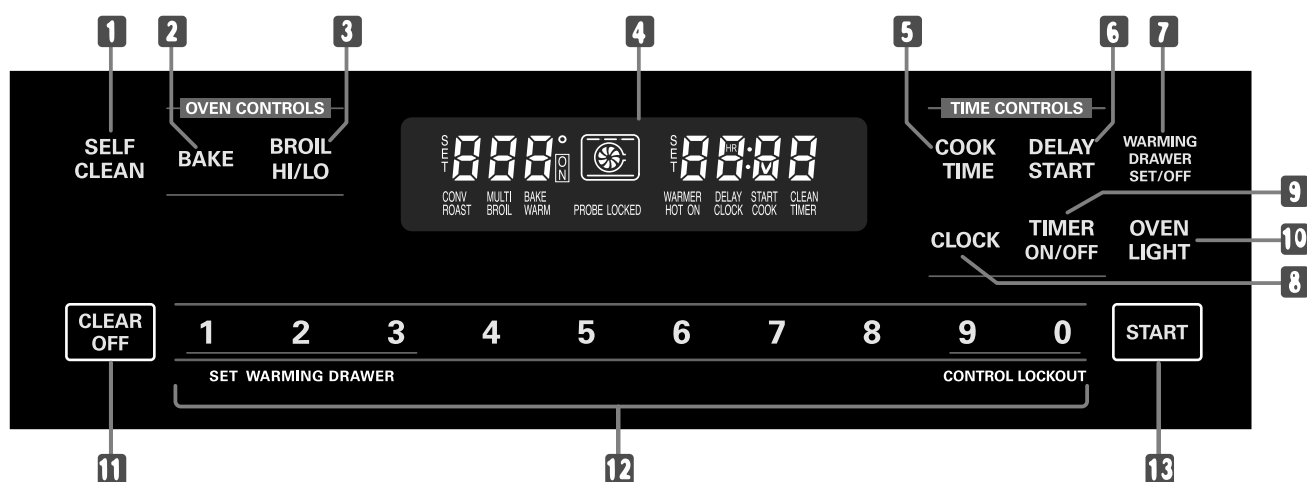

Non-Convection Models - Oven Control, Clock and Timer Features

1. **SELF CLEAN PAD:** Touch this pad to select self-cleaning function. See the Using the self-cleaning oven section.
 2. **BAKE PAD:** Touch this pad to select the bake function.
 3. **BROIL HI/LO PAD:** Touch this pad to select the broil function.
 4. **DISPLAY:** Shows the time of day, oven temperature, whether the oven is in the bake, broil or self-cleaning mode and the times set for the timer or automatic oven operations. It will also show warming drawer settings.
- Note:** If “F– and a number or letter” flash in the display and the oven control signals, this indicates a function error code.
- If your oven was set for a timed oven operation and a power outage occurred, the clock and all programmed functions must be reset.
- The time of day will flash in the display when there has been a power outage. Reset the clock.
- If “Err” appears in the display, you have tried to set a time or temperature outside of the control’s limits. Touch CLEAR/OFF pad and enter a new setting.
- Touch the CLEAR/OFF pad. Allow oven to cool for one hour. Put oven back into operation. If function error code repeats, disconnect power to range and call for service.
5. **COOK TIME PAD:** Touch this pad and then touch the number pads to set the amount of time you want your food to cook. The oven will shut off when the cooking time has run out.
 6. **DELAY START PAD:** Use along with COOK TIME or SELF CLEAN pads to set the oven to start and stop automatically at a time you set.
 7. **WARMING DRAWER PAD:** Touch this pad and then touch number pads 1–3 to use the warming drawer. See the Using the electric warming drawer section.
 8. **CLOCK PAD:** Press before setting the time of day.
 9. **TIMER ON/OFF PAD:** Press to select the timer feature.
 10. **OVEN LIGHT PAD:** Touch this pad to turn the oven light on or off.
 11. **CLEAR/OFF PAD:** Touch this pad to cancel ALL oven operations except the clock, timer and warming drawer settings.
 12. **NUMBER PADS:** Use to set any function requiring numbers such as time of day on the clock, timer, oven temperature, internal food temperature, start time and length of operation for timed baking and self-cleaning.
 13. **START PAD:** Must be touched to start any cooking or cleaning function, and warming drawer settings.

Oven Vent

Your oven is vented through ducts at the rear of the range. Do not block these ducts when cooking in the oven—it is important that the flow of hot air from the oven and fresh air to the oven burner be uninterrupted. Avoid touching the vent openings or nearby surfaces during oven or broiler operation—they may become hot.

- Handles of pots and pans on the cooktop may become hot if left too close to the vent.
- Do not leave plastic or flammable items on the cooktop—they may melt or ignite if left too close to the vent.
- Do not leave closed containers on the cooktop. The pressure in closed containers may increase, which may cause them to burst.
- Metal items will become very hot if they are left on the cooktop, and could cause burns.

How to Set the Oven for Baking or Roasting

Your oven is not designed for open-door cooking.

1. Touch the BAKE pad.
2. Touch the number pads to set the desired temperature.
3. Touch the START pad. The word ON and 100°F (40° if set for celsius), will be displayed. As the oven heats up, the display will show the changing temperature. When the oven reaches the temperature you set, a tone will sound.
Note: To change the oven temperature during BAKE cycle, press the BAKE pad and then the number pads to get the new temperature.
4. Check food for doneness at minimum time on recipe. Cook longer if necessary.
5. Touch the CLEAR/OFF pad when cooking is complete.

How to Set the Oven for Broiling

Your oven is not designed for open-door cooking.

1. Place the meat or fish on the broiler grid in the broiler pan.
2. Follow suggested shelf positions in the Broiling Guide (page 15 of Use & Care.)
3. The oven door must be closed during broiling.
4. Touch the BROIL HI/LO pad once for HI Broil. To change to LO Broil, touch the BROIL HI/LO pad again.
5. Touch the START pad.
6. When broiling is finished, touch the CLEAR/OFF pad.

Using the Clock and Timer

To Set the Clock

The clock must be set to the correct time of day for the automatic oven timing functions to work properly. The time of day cannot be changed during a timed baking or self-cleaning cycle.

1. On models with a CLOCK pad, touch it once to set.
2. Touch the number pads the same way you read them. For example, to set 12:34, touch the number pads 1, 2, 3 and 4 in that order.
If number pads are not touched within one minute after you touch the CLOCK pad, the display reverts to the original setting. If this happens, touch the CLOCK pad and reenter the time of day.
3. Touch the START pad until the time of day shows in the display. This enters the time and starts the clock.

To check the time of day when the display is showing other information:

On models with a CLOCK pad, simply touch the CLOCK pad.

To Set the Timer

The timer does not control oven operations. The maximum setting on the timer is 9 hours and 59 minutes.

1. Touch the TIMER ON/OFF pad.
2. Touch the number pads until the amount of time you want shows in the display. The maximum time that can be entered in minutes is 59. Times more than 59 minutes should be changed to hours and minutes. For example, to enter 90 minutes as 1 hour 30 minutes, touch 1, 3 and 0 in that order.

Note: If you make a mistake, press the TIMER ON/OFF pad and begin again.

3. Touch the START pad. After pressing the START pad, SET disappears; this tells you the time is counting down, although the display does not change until one minute has passed.
4. When the timer reaches :00, the control will beep 3 times followed by one beep every 6 seconds until the TIMER ON/OFF pad is touched.

The 6 second tone can be canceled by following the steps in the Special features of your oven control section under Tones at the End of a Timed Cycle.

Note: The timer is a minute timer only. The CLEAR/OFF pad does not affect the timer.

To Reset the Timer

If the display is still showing the time remaining, you may change it by touching the TIMER ON/OFF pad, then touch the number pads until the time you want appears in the display.

If the remaining time is not in the display (clock, delay start or cooking time are in the display), recall the remaining time by touching the TIMER ON/OFF pad and then touching the number pads to enter the new time you want.

To Cancel the Timer

Touch the TIMER ON/OFF pad twice.

Power Outage

If a flashing time is in the display, you have experienced a power failure. Reset the clock.

On models with a CLOCK pad, touch it once to reset. Enter the correct time of day by touching the appropriate number pads. Touch the START pad.

Using the Timed Baking and Roasting Features

Note: Foods that spoil easily—such as milk, eggs, fish, stuffings, poultry and pork—should not be allowed to sit for more than 1 hour before or after cooking. Room temperature promotes the growth of harmful bacteria. Be sure that the oven light is off because heat from the bulb will speed harmful bacteria growth.

To Set an Immediate Start and Automatic Stop

The oven will turn on immediately and cook for a selected length of time. At the end of the cooking time, the oven will turn off automatically.

1. Touch the BAKE pad.
2. Touch the number pads to set the desired oven temperature.
3. Touch the COOK TIME pad.

Note: If your recipe requires preheating, you may need to add additional time to the length of the cooking time.

4. Touch the number pads to set the desired length of cooking time. The minimum cooking time you can set is 1 minute. The oven temperature. And the cooking time entered will be in the display.
5. Touch the START pad.

The oven will turn ON, and the display will show the cooking time countdown and the changing temperature starting at 100°F (40° if set for Celsius). The temperature display will start to change once the oven temperature reaches 100°F (40°C). When the oven reaches the temperature you set, 3 beeps will sound.

The oven will continue to cook for the set amount of time, then turn off automatically, unless the Cook and Hold feature was set. See the Special features of your oven control section.

After the oven turns off, the end-of-cycle tone will sound.

6. Touch the CLEAR/OFF pad to clear the display if necessary. Remove the food from the oven. Remember, even though the oven turns off automatically, food left in the oven will continue cooking after the oven turns off.

To Set a Delayed Start and Automatic Stop

The oven will turn on at the time of day you set, cook for a specific length of time and then turn off automatically. Make sure the clock shows the correct time of day.

1. Touch the BAKE pad.
2. Touch the number pads to set the desired oven temperature.
3. Touch the COOK TIME pad.

Note: If your recipe requires preheating, you may need to add additional time to the length of the cooking time.

4. Touch the number pads to set the desired length of cooking time. The minimum cooking time you can set is 1 minute. The oven temperature. And the cooking time entered will be in the display.
5. Touch the DELAY START pad.
6. Touch the number pads to set the time of day you want the oven to turn on and start cooking.
7. Touch the START pad.

Note: An attention tone will sound if you are using timed baking and do not touch the START pad.

Note: If you would like to check the times you have set, touch the DELAY START pad to check the start time you have set or touch the COOK TIME pad to check the length of cooking time you have set.

When the oven turns ON at the time of day you set, the display will show the cooking time countdown and the changing temperature starting at 100°F (40° if set on Celsius). The temperature display will start to change once the oven temperature reaches 100°F (40°C). When the oven reaches the temperature you set, beeps will sound.

The oven will continue to cook for the set amount of time, then turn off automatically, unless the Cook and Hold feature was set. See the Special features of your oven control section.

8. After the oven turns off, the end-of-cycle tone will sound. Touch the CLEAR/OFF pad to clear the display if necessary. Remove the food from the oven. Remember, even though the oven turns off automatically, food left in the oven will continue cooking after the oven turns off.

Using the Probe (Convection Models)

For many foods, internal food temperature is the best test for doneness. The temperature probe takes the guesswork out of cooking foods to the exact doneness you want.

Use of probes other than the one provided with this product may result in damage to the probe.

Use the handles of the probe and plug when inserting and removing them from the food and outlet.

- To avoid damaging your probe, do not use tongs to pull on the cable when removing it.
- To avoid breaking the probe, make sure food is completely defrosted before inserting.
- To prevent possible burns, do not unplug the probe from the outlet until the oven has cooled.
- Never leave your probe inside the oven during a self-cleaning cycle.
- Do not store the probe in the oven.

After preparing the meat and placing it on a trivet or on the broiler pan grid, follow these directions for proper probe placement.

Insert the probe completely into the meat. It should not touch the bone, fat or gristle.

For roasts with no bone, insert the probe into the meatiest part of the roast. For bone-in ham or lamb, insert the probe into the center of the lowest large muscle.

Insert the probe into the center of dishes such as meat loaf or casseroles.

Insert the probe into the meatiest part of the inner thigh from below and parallel to the leg of a whole turkey.

To Set Oven For Cooking when Using Probe

1. Insert the probe into the food.
2. Plug the probe into the outlet in the oven. Make sure it's pushed all the way in. Close the oven door.
3. Touch the PROBE pad.
4. Touch the number pads to set the desired internal food or meat temperature between 100°F (38°C) and 200°F (93°C).
5. Touch the BAKE pad.
6. Touch the number pads to set the desired oven temperature.
7. Touch the START pad.
8. When the internal temperature of the food reaches the number you have set, the probe and the oven turn off and the oven control signals. To stop the signal, touch the CLEAR/OFF pad. Use hot pads to remove the probe from the food. Do not use tongs to pull on it, they might damage it.

To change the oven temperature during probe cooking, touch the BAKE pad and then the number pads to set the new temperature.

Note: If the probe is removed from the food before the final temperature is reached, a tone will sound and the display will flash until the probe is removed from the oven. You can use the timer even though you cannot use timed oven operations while using the probe.

Using the Convection Oven

The convection oven fan shuts off when the oven door is opened. DO NOT leave the door open for long periods of time while using convection cooking.

To help you understand the difference between convection bake and roast and traditional bake and roast, here are some general guidelines.

Convection Bake

- Preheat the oven. See the Using the Oven—Preheating and Pan Placement section.
- Ideal for foods cooked on multiple shelves.
- Good for large quantities of baked foods
- Good results with cookies, biscuits, brownies, cupcakes, cream puffs, sweet rolls, angel food cake and bread.

The convection fan circulates the heated air evenly over and around the food.

Convection Roast

- Good for large tender cuts of meat, uncovered.

The convection fan circulates the heated air evenly over and around the food. Using the grid and broiler pan provided, heated air will be circulated over and around the food being roasted. The heated air seals in juices quickly for a moist and tender product while, at the same time, creating a rich golden brown exterior.

When you are convection roasting it is important that you use the broiler pan and grid for best convection roasting results. The pan is used to catch grease spills and the grid is used to prevent grease spatters.

- Place the shelf in the second shelf position from the bottom.
- Place the grid on the broiler pan.

Auto Recipe™ Conversion

You can use your favorite recipes in the convection oven.

When using CONVECTION BAKE, the oven will automatically convert the oven temperature from regular baking to Convection Bake temperatures.

1. Using the number pads, enter the temperature recommended in the recipe.
2. Touch the START pad. The display will show the temperature you entered from your recipe. The

oven will automatically convert it to the convection cooking temperature.

3. Touch the CLEAR/OFF pad when baking is finished.

Note: Use pan size recommended in the recipe. Some package instructions for frozen casseroles, main dishes or baked goods have been developed using commercial convection ovens. For best results in this oven, preheat the oven and use the temperature, for regular baking, on the package.

Cookware for Convection Cooking

Before using your convection oven, check to see if your cookware leaves room for air circulation in the oven. If you are baking with several pans, leave space between them. Also, be sure the pans do not touch each other or the walls of the oven.

Paper and Plastic: Heat-resistant paper and plastic containers that are recommended for use in regular ovens can be used in convection ovens. Plastic cookware that is heat-resistant to temperatures of 400°F (204°C) can also be used, when oven is below 400°F (204°C).

Metal and Glass: Any type of cookware will work in your convection oven. However, metal pans heat the fastest and are recommended for convection baking.

- Darkened or matte-finished pans will bake faster than shiny pans.
- Glass or ceramic pans cook more slowly.

To Set the Oven for Convection Baking or Roasting

1. Touch the CONVECTION BAKE or CONVECTION ROAST pad.
2. Touch the number pads to set the desired oven temperature.
3. Touch the START pad.

To change the oven temperature, touch the CONVECTION BAKE or CONVECTION ROAST pad and then the number pads to set the new temperature.

When the oven starts to heat the changing temperature, starting at 100°F, will be displayed. When the oven reaches the temperature you set, 3 beeps will sound.

4. Touch the CLEAR/OFF pad when finished.

Note: You will hear a fan while cooking with convection. The fan will stop when the door is opened but the heat will not turn off. The fan will not start until the preheat temperature is reached.

Multi-Shelf Baking

Because heated air is circulated evenly throughout the oven, foods can be baked with excellent results using multiple shelves.

Multi-shelf baking may increase cook times slightly for some foods but the overall result is time saved.

To Set the Oven for Convection Roasting when Using the Probe (Convection Models)

The display will flash PROBE and the oven control will signal if the probe is inserted into the outlet, and you have not set a probe temperature and touched the START pad.

1. Place the shelf in the second shelf position from the bottom. Insert the probe completely into the food.
2. Plug the probe into the outlet in the oven. Make sure it is pushed all the way in. Close the oven door.
3. Touch the CONVECTION ROAST pad.
4. Touch the number pads to set the desired oven temperature.
5. Touch the PROBE pad.
6. Touch the number pads to set the desired internal food temperature.

To change the oven temperature during the Convection Roast cycle, touch the CONVECTION ROAST pad and then touch the number pads to set the new desired temperature.

7. Touch the START pad.

When the oven starts to heat, the word LO will be in the display.

After the internal temperature of the food reaches 100°F (38°C), the changing internal temperature will be shown in the display.

8. When the internal temperature of the food reaches the number you have set, the probe and the oven turn off and the oven control signals. To stop the signal, touch the CLEAR/OFF pad. Use hot pads to remove the probe from the food. Do not use tongs to pull on it, they might damage it.
- If the probe is removed from the food before the final temperature is reached, a tone will sound and the display will flash until the probe is removed from the oven.
 - You will hear a fan while cooking with this feature. The fan will stop when the door is opened but the heat will not turn off.
 - You can use the timer even though you cannot use timed oven operations while using the probe.

Using the Timed Convection Baking and Roasting Features (Convection Models)

You will hear a fan while cooking with this feature. The fan will stop when the door is opened but the heat will not turn off.

To Set an Immediate Start and Automatic Stop

The oven will turn ON immediately and cook for a selected length of time. At the end of the cooking time, the oven will turn OFF automatically.

1. Touch the CONVECTION BAKE pad.
2. Touch the number pads to set the desired oven temperature.
3. Touch the COOK TIME pad.
4. Touch the number pads to set the desired length of cooking time. The minimum cooking time you can set is 1 minute.
5. Touch the START pad.

The oven will turn ON, and the display will show the cooking time countdown and the changing temperature starting at 100°F. (The temperature display will start to change once the oven temperature reaches 100°F.) When the oven reaches the temperature you set, 3 beeps will sound.

The oven will continue to cook for the set amount of time, then turn off automatically, unless the Cook and Hold feature was set. See the Special features of your oven control section.

After the oven turns OFF, the end-of-cycle tone will sound.

6. Touch the CLEAR/OFF pad to clear the display if necessary. Remove the food from the oven. Remember, even though the oven turns off automatically, food left in the oven will continue cooking after the oven turns off.

To Set a Delayed Start and Automatic Stop

The oven will turn on at the time of day you set, cook for a specific length of time and then turn off automatically. Make sure the clock shows the correct time of day.

1. Touch the CONVECTION BAKE pad.
2. Touch the number pads to set the desired oven temperature.
3. Touch the COOK TIME pad.
4. Touch the number pads to set the desired length of cooking time. The minimum cooking time you can set is 1 minute. The oven temperature that you set and the cooking time that you entered will be in the display.
5. Touch the DELAY START pad.
6. Touch the number pads to set the time of day you want the oven to turn on and start cooking.
7. Touch the START pad.

Note: To check the times you have set, touch the DELAY START pad to check the start time you have set or touch the COOK TIME pad to check the length of cooking time you have set.

When the oven turns ON at the time of day you set, the display will show the cooking time countdown and the changing temperature starting at 100°F (40° if set for Celcius). The temperature display will start to change once the oven temperature reaches 100°F (40°C). When the oven reaches the temperature you set, 3 beeps will sound.

The oven will continue to cook for the set amount of time, then turn off automatically, unless the Cook and Hold feature was set. See the Special features of your oven control section.

After the oven turns off, the end-of-cycle tone will sound.

8. Touch the CLEAR/OFF pad to clear the display if necessary. Remove the food from the oven. Remember, even though the oven turns off automatically, food left in the oven will continue cooking after the oven turns off.

Special Features of the Oven Control

Your new touch pad control has additional features that you may choose to use. The following are the features and how you may activate them.

The special feature modes can only be activated while the display is showing the time of day. They remain in the control's memory until the steps are repeated.

When the display shows your choice, touch the START pad. The special features will remain in memory after a power failure.

12 Hour Shut Off

With this feature, should you forget and leave the oven or warming drawer on, the control will automatically turn them off. The warming drawer will be turned off after 12 hours. The oven will be turned off after 12 hours during baking functions or after 3 hours during a broil function.

If you wish to turn OFF this feature, follow the steps below.

1. Touch the BAKE and BROIL HI/LO pads at the same time for 3 seconds until the display shows SF.
2. Touch the DELAY START pad. The display will show **12 shdn** (12 hour shut off). Touch the DELAY START pad again and the display will show **no shdn** (no shut off).
3. Touch the START pad to activate the no shut-off and leave the control set in this special features mode.

Fahrenheit or Celsius Temperature Selection

Your oven control is set to use the Fahrenheit temperature selections but you may change this to use the Celsius selections.

1. Touch the BAKE and BROIL HI/LO pads at the same time for 3 seconds until the display shows SF.
2. Touch the BROIL HI/LO and COOK TIME pads at the same time. The display will show F (Fahrenheit).
3. Touch the BROIL HI/LO and COOK TIME pads again at the same time. The display will show C (Celsius).
4. Touch the START pad.

Tones at the End of a Timed Cycle

At the end of a timed cycle, 3 short beeps will sound followed by one beep every 6 seconds until the CLEAR/OFF pad is touched. This continual 6-second beep may be canceled.

To cancel the 6-second beep:

1. Touch the BAKE and BROIL HI/LO pads at the same time for 3 seconds until the display shows SF.
2. Touch the TIMER ON/OFF pad. The display shows CON BEEP (continual beep) and BEEP. Touch the TIMER ON/OFF pad again. The display shows BEEP. (This cancels the one beep every 6 seconds.)
3. Touch the START pad.

Special Features of the Oven Control

Control Lockout

Your control will allow you to lock out the touch pads so they cannot be activated when touched or cleaning the glass panel.

To lock the controls:

1. Touch the 9 and 0 touch pads at the same time for 3 seconds until the control beeps twice. The display will show LOC continuously and the time of day if not blacked out.

Note: All cooking and timing functions will be cancelled when locking out the control.

2. To unlock the control, touch the 9 and 0 touch pads at the same time for 3 seconds until the control beeps twice, and LOC will be removed from the display.

12-Hour, 24-Hour or Clock Blackout

Your control is set to use a 12-hour clock.

If you would prefer to have a 24-hour military time clock or black out the clock display, follow the steps below.

1. Touch the BAKE and BROIL HI/LO pads at the same time for 3 seconds until the display shows SF.
2. On models with a CLOCK pad, touch the CLOCK pad once. The display will show 12 hr. If this is the choice you want, touch the START pad

Touch the CLOCK pad again to change to the 24-hour military time clock. The display will show 24 hr. If this is the choice you want, touch the START pad.

Touch the CLOCK pad again to black out the clock display. The display will show OFF. If this is the choice you want, touch the START pad.

Cook and Hold

Your new control has a cook and hold feature that keeps cooked foods warm for up to 3 hours after the cooking function is finished. This feature can only be used when timed cooking.

To activate this feature, follow the steps below:

1. Touch the BAKE and BROIL HI/LO pads at the same time for 3 seconds until the display shows SF.
2. Touch the COOK TIME pad. The display will show Hld OFF. Touch the COOK TIME pad again to activate the feature. The display will show Hld ON.
3. Touch the START pad to activate the cook and hold feature and leave the control set in this special features mode.

Using the Sabbath Feature (Designed for use on the Jewish Sabbath and holidays)

The Sabbath feature can be used for baking/roasting in the oven only. It cannot be used for convection, broiling, self cleaning or Delay Start cooking.

Note: The oven light comes on automatically when the door is opened and goes off when the door is closed. The bulb may be removed. On models with a light switch on the control panel, the oven light may be turned on and left on.

How to Set for Regular Baking/Roasting (In Sabbath Mode)

Make sure the clock shows the correct time of day and the oven is off.

1. Press and hold both the BAKE and BROIL HI/LO pads, at the same time, until the display shows SF.
2. Tap the DELAY START pad until SAb bAtH appears in the display.
3. Touch the START pad and \supset will appear in the display.

When the display shows \supset the oven is set in Sabbath. When the display shows $\supset \subset$ the oven is in baking/roasting.

4. Touch the BAKE pad. No signal will be given.
5. Using the number pads, enter the desired temperature between 170°F and 550°F. No signal or temperature will be given.
6. Touch the START pad.
7. After a random delay period of approximately 30 seconds to 1 minute, $\supset \subset$ will appear in the display indicating that the oven is baking/roasting. If $\supset \subset$ doesn't appear in the display, start again at Step 4.

To adjust the oven temperature, touch the BAKE pad, enter the new temperature using the number pads, and touch the START pad.

Note: The CLEAR/OFF and COOK TIME pads are active during the Sabbath feature.

How to Set for Timed Baking/Roasting— Immediate Start and Automatic Stop (In Sabbath Mode)

Make sure the clock shows the correct time of day and the oven is off.

1. Press and hold both the BAKE and BROIL HI/LO pads, at the same time, until the display shows SF.
2. Tap the DELAY START pad until SAb bAtH appears in the display.

3. Touch the START pad and \supset will appear in the display.

When the display shows \supset the oven is set in Sabbath. When the display shows $\supset \subset$ the oven is in baking/roasting.

4. Touch the COOK TIME pad.
5. Touch the number pads to set the desired length of cooking time between 1 minute and 9 hours and 99 minutes. The cooking time that you entered will be displayed.
6. Touch the START pad.
7. Touch the BAKE pad. No signal will be given.
8. Using the number pads, enter the desired temperature. No signal or temperature will be given.
9. Touch the START pad.
10. After a random delay period of approximately 30 seconds to 1 minute, $\supset \subset$ will appear in the display indicating that the oven is baking/roasting. If $\supset \subset$ doesn't appear in the display, start again at Step 7.

To adjust the oven temperature, touch the BAKE pad, enter the new temperature using the number pads, and touch the START pad.

When cooking is finished, the display will change from $\supset \subset$ to \supset and 0:00 will appear, indicating that the oven has turned OFF but is still set in Sabbath. Remove the cooked food.

How to Exit the Sabbath Feature

1. Touch the CLEAR/OFF pad.
2. If the oven is cooking, wait for a random delay period of approximately 30 seconds to 1 minute, until only \supset is in the display.
3. Press and hold both the BAKE and BROIL HI/LO pads, at the same time, until the display shows SF.
4. Tap the DELAY START pad until 12 shdn or no shdn appears in the display. 12 shdn indicates that the oven will automatically turn off after 12 hours. no shdn indicates that the oven will not automatically turn off.
5. Touch the START pad.

Note: If a power outage occurred while the oven was in Sabbath, the oven will automatically turn off and stay off even when the power returns. The oven control must be reset.

(Continued next page)

Using the Electric Warming Drawer

To Use the Warming Drawer:

1. Touch the WARMING DRAWER pad. “Hot” and “1” are lit on the display and “Set” begins to blink.
2. On the number pad, press 1 for Low, 2 for Medium or 3 for High. The display “1” changes corresponding to the number pad selected.
3. Touch the START pad. “Hot” and the number remain lit. “Set” stops blinking.

To cancel the Warming Drawer:

Touch the WARMING DRAWER pad.

Note: Touching the CLEAR/OFF pad does not turn the warming drawer off.

Number Pad	Setting
1	Lo (pies)
2	Med (casseroles)
3	Hi (meats)

Notes: The warming drawer cannot be used during a self-clean cycle.

- The warming drawer has three settings: 1, 2 and 3. These settings maintain different temperature levels in the warming drawer.
- On some models, if using the oven at the same time as the warming drawer, only the oven settings will be displayed.

When Using the Warming Drawer

Always start with hot food. Do not use to heat cold food other than crisping crackers, chips or dry cereal.

Do not line the warming drawer or pan with aluminum foil. Foil is an excellent heat insulator and will trap heat beneath it. This will upset the performance of the drawer and could damage the interior finish.

Allow approximately 25 minutes for the warming drawer to preheat.

- Do not put liquid or water in the warming drawer.
- For moist foods, cover them with a lid or aluminum foil.
- For crisp foods, leave them uncovered.
- Food should be kept hot in its cooking container or transferred to a heat-safe serving dish.
- Remove serving spoons, etc., before placing containers in warming drawer.

Self Cleaning Oven

Before a Clean Cycle

For the first self-clean cycle, we recommend venting your kitchen with an open window or using a ventilation fan or hood.

Remove the broiler pan, broiler grid, all cookware, probe and any aluminum foil from the oven—they cannot withstand the high cleaning temperatures.

Note: If your oven is equipped with nickel oven shelves, remove them before you begin the self-clean cycle.

Soil on the front frame of the range and outside the gasket on the door will need to be cleaned by hand. Clean these areas with hot water, soap-filled scouring pads or cleansers such as Soft Scrub®. Rinse well with clean water and dry.

Do not clean the gasket. The fiberglass material of the oven door gasket cannot withstand abrasion. It is essential for the gasket to remain intact. If you notice it becoming worn or frayed, replace it.

Wipe up any heavy spill overs on the oven bottom. Make sure the oven light bulb cover is in place and the oven light is off.

IMPORTANT: The health of some birds is extremely sensitive to the fumes given off during the self-cleaning cycle of any range. Move birds to another well ventilated room.

Note: Use caution when opening the oven after the self-clean cycle has ended. The oven may still be hot.

How to Set the Oven For Cleaning

1. Touch the SELF CLEAN pad.
2. Using the number pads, enter the desired clean time, if a time other than 4 hours 20 minutes is needed. (Clean cycle time is normally 4 hours 20 minutes. You can change the clean time to any time between 3 hours and 5 hours, depending on how dirty your oven is.)
3. Touch the START pad.

The door locks automatically. The display will show the clean time remaining. It will not be possible to open the oven door until the temperature drops below the lock temperature and the LOCKED light goes off.

The oven shuts off automatically when the clean cycle is complete.

4. When the LOCKED light is off, the door will be unlocked.

(Continued next page)

- The word LOCKED will flash and the oven control will signal if you set the clean cycle and forget to close the oven door.
- To stop a clean cycle, touch the CLEAR/OFF pad. When the LOCKED light goes off, indicating the oven has cooled below the locking temperature, the door can be opened.

The oven door must be closed and all controls set correctly for the cycle to work properly.

How to Delay the Start of Cleaning

Make sure the clock shows the correct time of day.

1. Touch the SELF CLEAN pad.
2. Using the number pads, enter the desired clean time.
3. Touch the DELAY START pad. The earliest start time you can set will appear in the display.
4. Using the number pads, enter the time of day you want the clean cycle to start.
5. Touch the START pad.

The door locks automatically. The display will show the start time. It will not be possible to open the oven door until the temperature drops below the lock temperature and the LOCKED light goes off. The oven shuts off automatically when the clean cycle is complete.

6. When the LOCKED light is off, the door will unlock automatically.
- The word LOCKED will flash and the oven control will signal if you set the clean cycle and forget to close the oven door.
 - To stop a clean cycle, touch the CLEAR/OFF pad. When the LOCKED light goes off indicating the oven has cooled below the locking temperature, and open the door.

After a Clean Cycle

You may notice some white ash in the oven. Wipe it up with a damp cloth after the oven cools.

If white spots remain, remove them with a soap-filled scouring pad and rinse thoroughly with a vinegar and water mixture.

Do not clean the gasket. The fiberglass material of the oven door gasket cannot withstand abrasion. It is essential for the gasket to remain intact. If you notice it becoming worn or frayed, replace it.

These deposits are usually a salt residue that cannot be removed by the clean cycle.

If the oven is not clean after one clean cycle, repeat the cycle.

- You cannot set the oven for cooking until the oven is cool enough for the door to unlock.
- While the oven is self-cleaning, you can touch the CLOCK pad to display the time of day. To return to the clean countdown, touch the COOK TIME pad.
- If the shelves become hard to slide, apply a small amount of vegetable oil or cooking oil to a paper towel and wipe the edges of the oven shelves with the paper towel.

Component Locator Views

Gas Range with Convection Fan - Front View

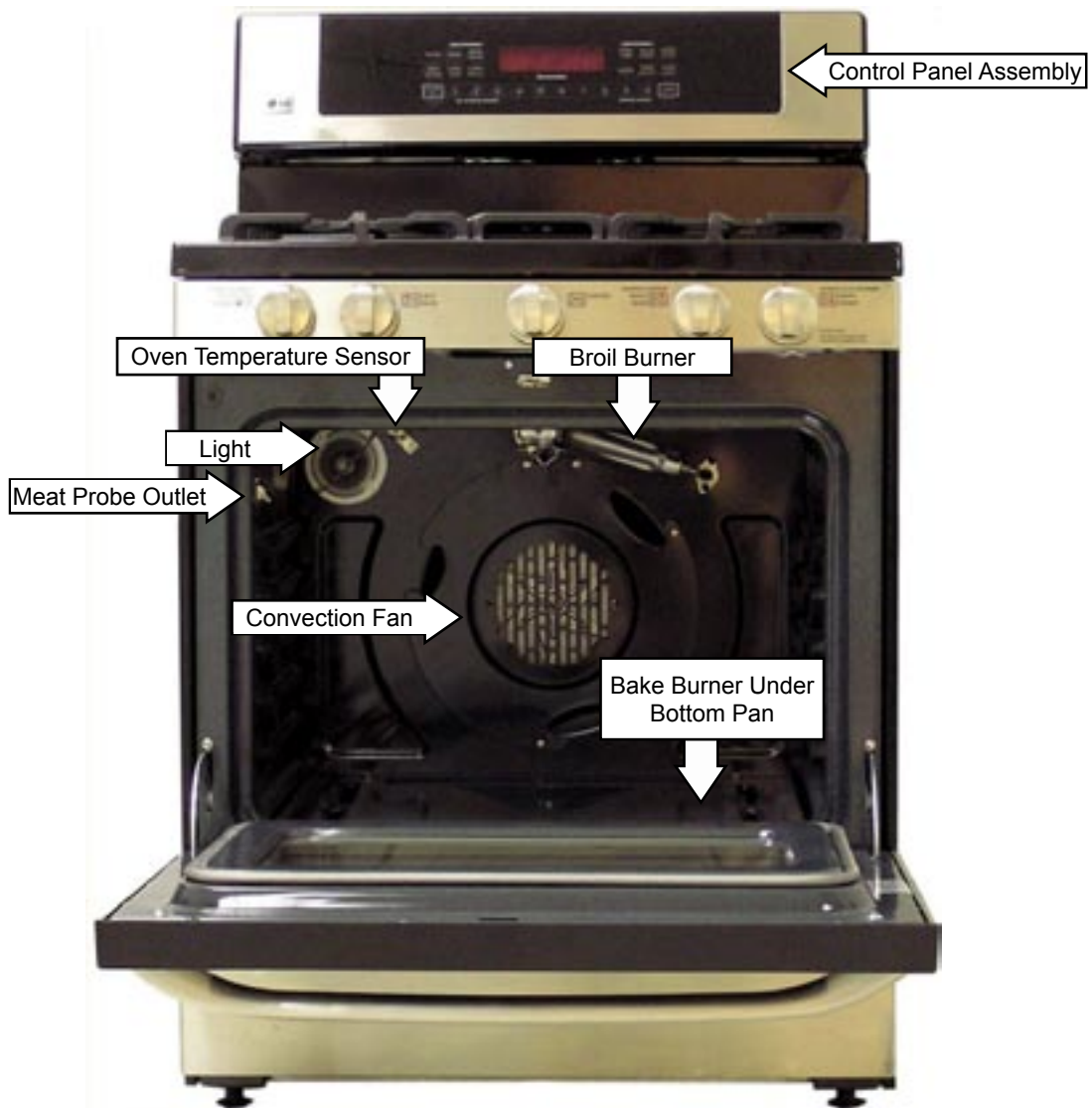

Warming Drawer Compartment

Shown with warming drawer removed.

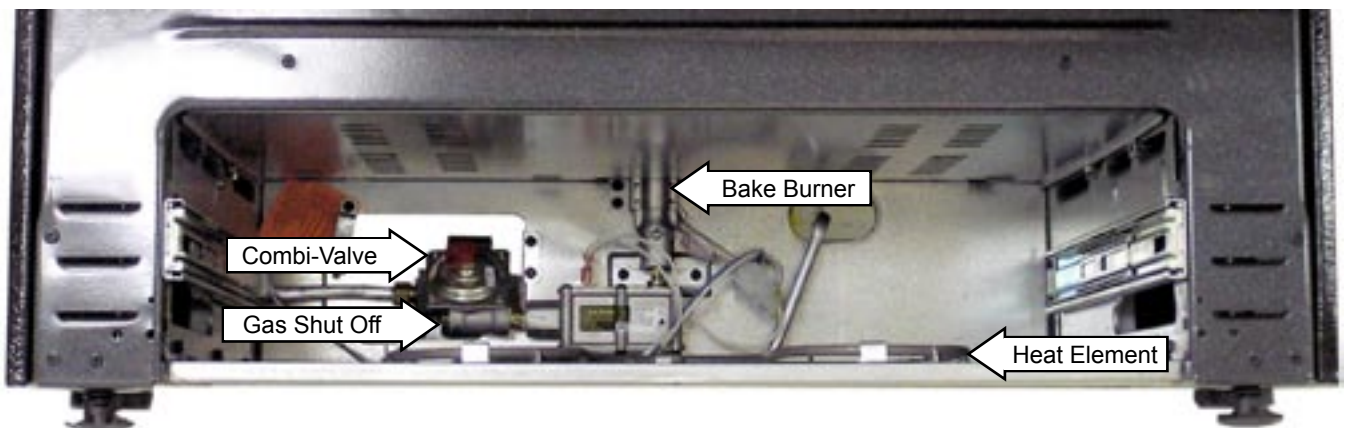

Maintop Burner Assembly



Control Panel

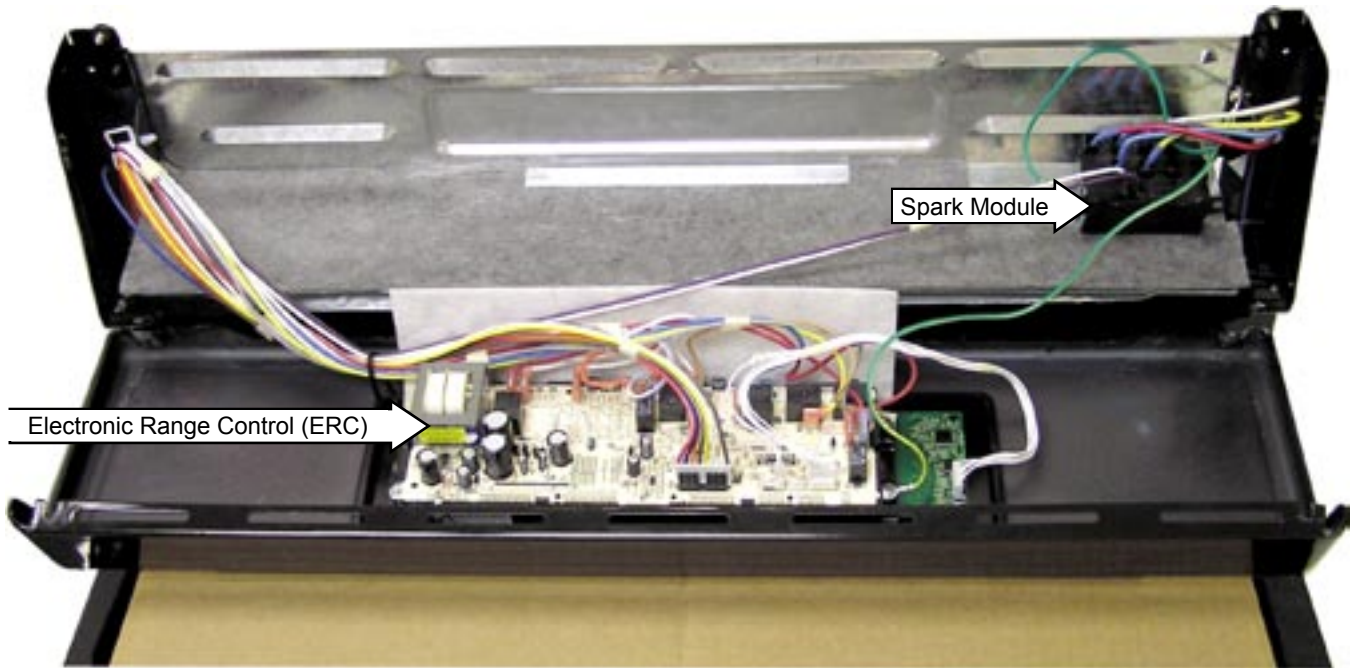

Shown in service position.

Maintop Burner Compartment

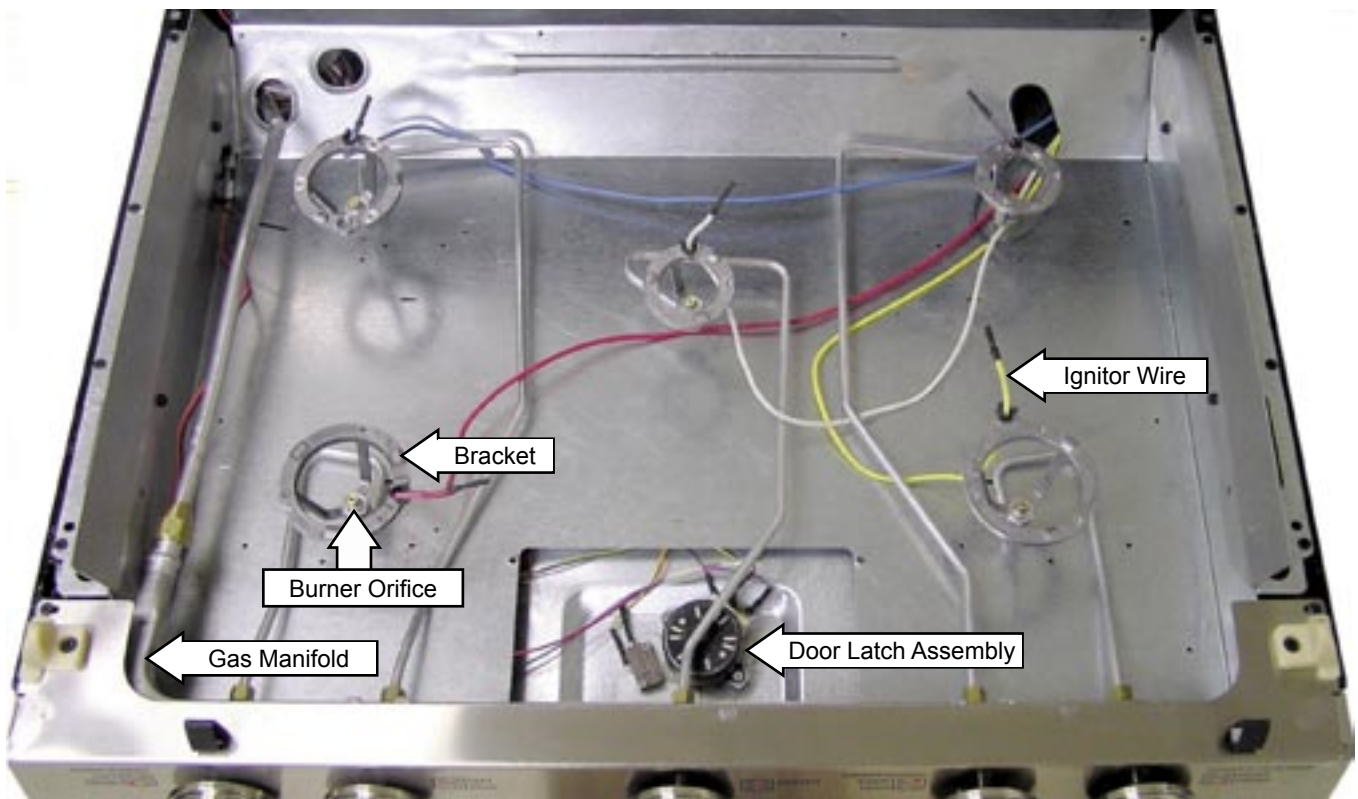

Shown with heat shield and door latch assembly cover removed.

Range Components and Replacement

WARNING: Sharp edges may be exposed when servicing. Use caution to avoid injury. Wear Kevlar gloves or equivalent protection.

Oven Door Removal

To remove the door:

Open the door to the first stop at the near vertical position. Firmly grasp the door at the top sides and lift the door up and pull straight out.

To install the door:

Firmly grasp the door at the top sides. Approach the range with the door angled in a near vertical position. Guide the hinge arm into the door slots and push the door in firmly. Close the oven door and check for proper alignment, rubbing, etc.

Note: If the door can not be fully closed, the door is not fully seated on the hinge arms.

Range Removal

Caution: Take the necessary precautions to protect the floor from damage caused by moving the range.

To remove the range:

Note: It may be helpful to remove the door to lighten the range for removal (See *Oven Door*.)

1. Lift the front of the range up while carefully pulling the range from the installation.
2. Continue to pull the range out while lifting up until the back of the range is accessible.

Note: Make sure the anti-tip bracket is installed correctly before pushing the range back into place.

Warming Drawer Removal

To remove and replace the warming drawer:

Pull the drawer out until it stops. Lift the tab on the left side and push down the tab on the right side while pulling the drawer out.

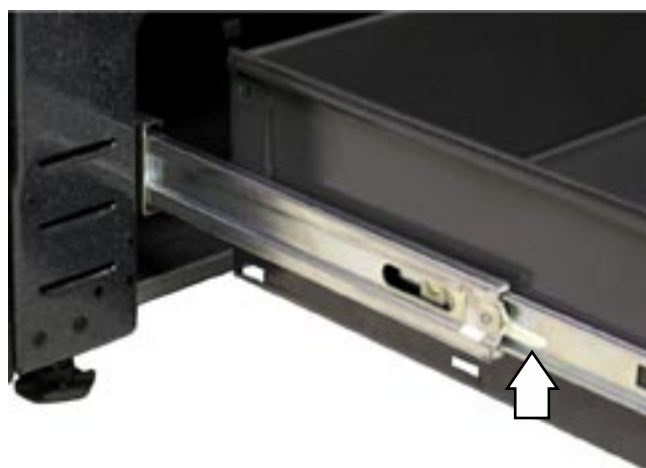

To replace the warming drawer, place the drawer rail in the guides and push the drawer in until it stops.

Warming Drawer Gasket

The gasket forms a seal around the top and sides of the warming drawer, and is located on the oven side of the drawer's inner panel. The warming drawer can be removed to access the gasket. (See *Warming Drawer Removal*.) The gasket is attached with integral clips. Use needle nose pliers to remove the clips and gasket from the drawer's inner panel.

Warming Drawer Element

WARNING: Before servicing the warming drawer, power must be disconnected from the range.

The warming drawer must be removed to access the warming drawer element. (See **Warming Drawer Removal**.) To disconnect the element wires it is necessary to remove the 2 T-15 Torx screws that attach the element terminal cover. The element is attached to the range with six ¼-in. hex-head screws and 6 clips.



3. Pull the track slide out.
4. Lift the front of the track slide approximately ½ inch, turn the track towards the middle of the range to disengage the front tab.

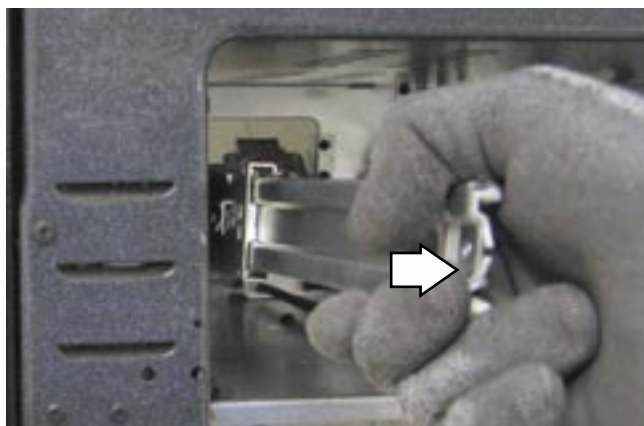

5. Pull the track towards the front of the range to disengage the rear tab.

Warming Drawer Tracks

Each of the 2 warming drawer tracks is held to the range with a single Phillips-head screw and 2 tabs.

To remove the warming drawer tracks:

1. Remove the warming drawer (See **Warming Drawer Removal**.)
2. Remove the single Phillips-head screw from the front of the drawer track.

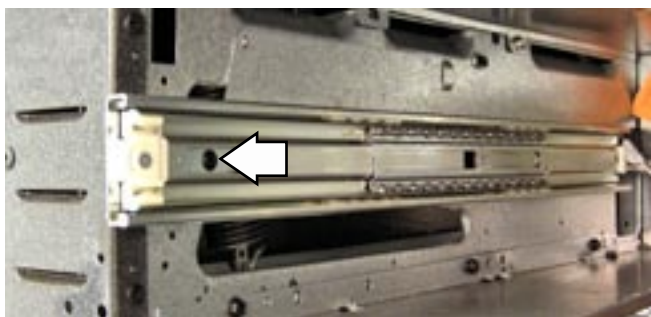

Gas Shut-off Valve

Note: The gas shut-off valve shuts off the gas to the oven only and has no effect on the top burners.

The gas shut-off valve is located on the side of the pressure regulator which is mounted on a bracket behind the warming drawer. Access to the shut-off valve lever is obtained by removing the warming drawer and reaching through the opening.

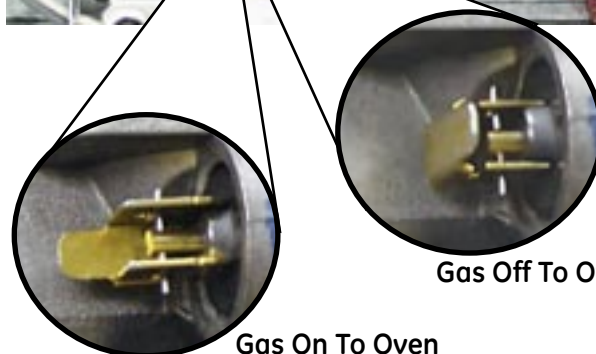
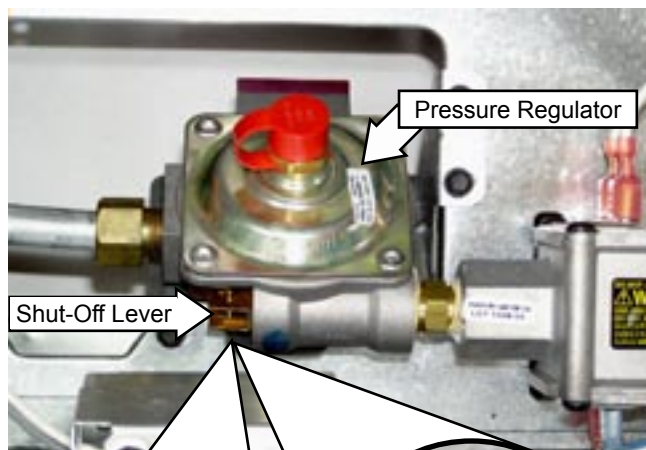

Maintop Removal

To remove the maintop:

Remove the grates, burner caps, burner heads, igniters, and the T-15 Torx screws from the cooktop.

Insert a putty knife or flat-blade screwdriver under the maintop to compress clips and remove the maintop.



6. Remove the Phillips-head screw from the bottom front under the hinge.



7. Remove four 1/4-in. hex-head screws from the back edge of the side panel.
8. Slide a putty knife or flat-blade screwdriver into the side panel under the manifold/valve panel and gently pry the side panel off the snap fastener.



Side Panel Removal

To remove the side panel:

1. Remove the range from installation (See *Range Removal.*)
2. Remove door (See *Oven Door Removal.*)
3. Remove warming drawer (See *Warming Drawer Removal.*)
4. Remove the Maintop. (See *Maintop.*)
5. Remove 6 Phillips-head screws from the top of side panel.

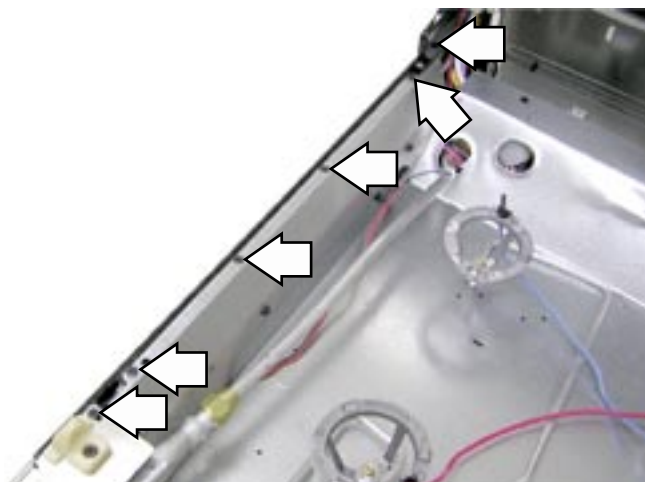

Oven Door Hinge Removal

To remove the oven door hinge:

1. Remove the range from installation (See *Range Removal.*)
2. Remove door (See *Oven Door Removal.*)
3. Remove warming drawer (See *Warming Drawer Removal.*)
4. Remove side panel (See *Side Panel Removal.*)
5. Note the position of the hinge spring and the paint indicator and remove the hinge spring.

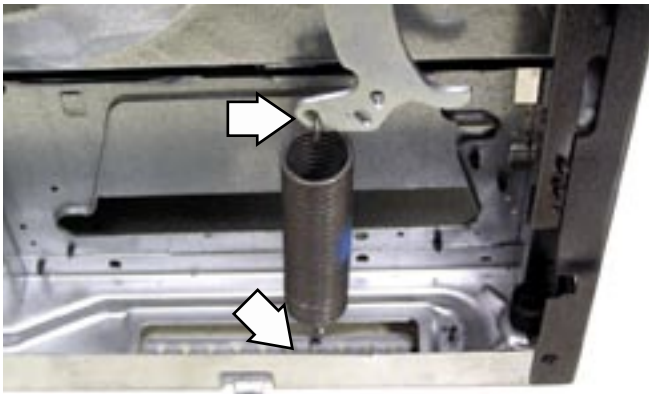

6. Remove the E-clip from the hinge pin and remove the hinge pin.



7. Remove the two ¼-in. hex-head screws that attach the hinge to the frame.



8. Position the top front of the hinge body into the notch in the hinge arm (see photo) and rotate the hinge body clockwise to remove.

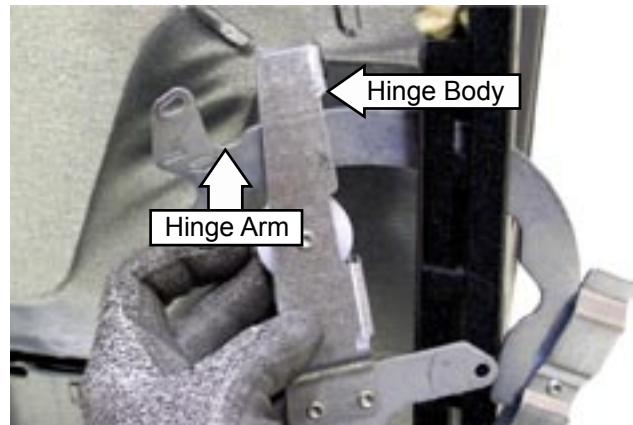

Door Assemblies

The doors can be separated into two assemblies: (1) Outer assembly which consists of handle, vent trim, outer glass, and frame; (2) Inner assembly which consists of inner panel, gasket, glass panels, and insulation. The assemblies are held together by one T-20 Torx screw on each top corner of the inner panel, and four ¼-in. hex-head screws across the bottom.

Self-Clean Door Gasket - The door gasket is held in place between the outer and inner sections of the inner door panel.

To remove the door assemblies:

1. Remove the oven door. (See *Oven Door*.)
2. Place the oven door inside up on a protected flat surface.
3. Remove two T-20 Torx screws and washers from the top corners of the inner panel, the 4 center ¼-in. hex-head screws from the bottom of the door, and remove the inner assembly.
4. Place the inner assembly on a flat protected surface with the inside up.
5. Remove the four ¼-in. hex-head screws, the inner door panel, and the insulation.

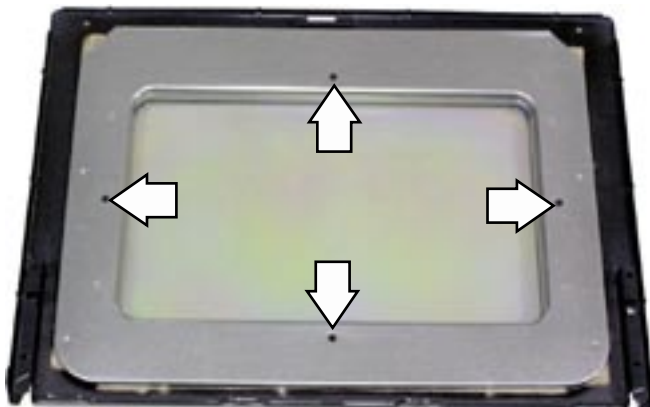

6. Remove the four ¼-in. hex-head screws from the outer frame and carefully lift off the outer frame.

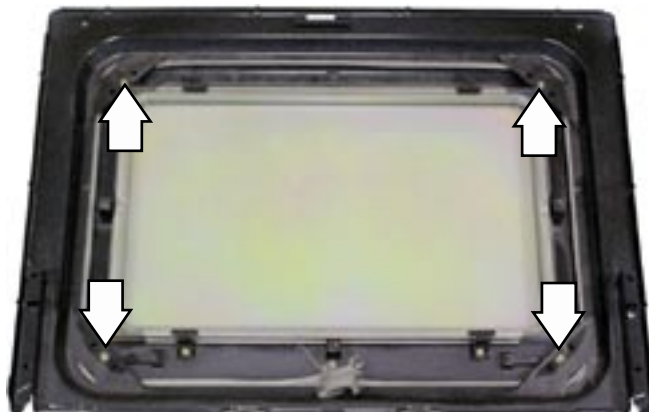

Note: When replacing the gasket, be sure the gasket bead is positioned uniformly between the outer and the inner sections of the inner door panel.

Oven Light Bulb



Caution: Before replacing the oven light bulb, disconnect the electrical power to the oven at the main fuse or circuit breaker panel.

Caution: The glass cover should be removed only when cold. Be sure to let the light cover and bulb cool completely. Do not touch a hot bulb with bare hands or a damp cloth.

Replace with a new 120V appliance lamp, not to exceed 40 watts.

If oven light is not working, make the following checks:

- Check oven light bulb.
- Light should come on when door is opened - check voltage across light socket terminals. It should read 120 VAC. If 0 volts, check door switch and wiring.

To remove and replace the oven light bulb:

1. Push the wire retainer to the side and remove the glass cover.
2. Unscrew the bulb and replace with a new 40 W, 120V appliance bulb.
3. Clean the glass cover using a wet cloth. This should be done when the oven is completely cool.
4. Reconnect electrical power to the oven.

Oven Door Switch

The oven door switch is located on the left side of the door frame and is accessible from the front.

Caution: Before removing the switch, disconnect the electrical power to the oven at the main fuse or circuit breaker panel.

To remove the door switch:

1. Pull the switch forward to locate the ends of 2 spring clips (1 on each side.)

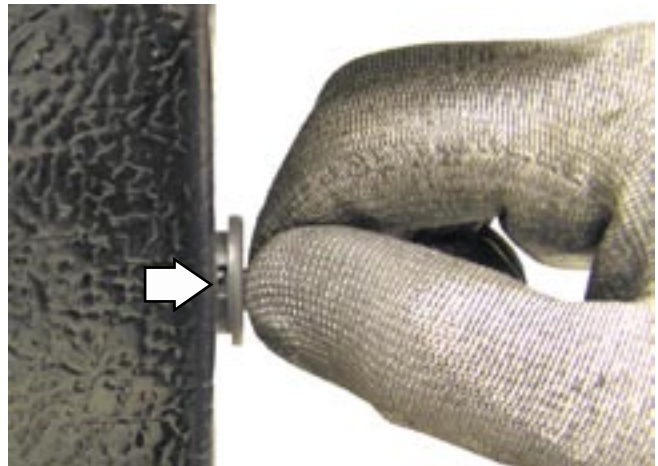

2. Insert a small flat-blade screwdriver on one of 2 spring clips and depress the spring clip while pulling the switch from the door frame.
3. Insert the small flat-blade screwdriver on the other spring clips, depress the spring clip, and continue pulling the switch from the door frame.
4. Disconnect the door switch wire harness.

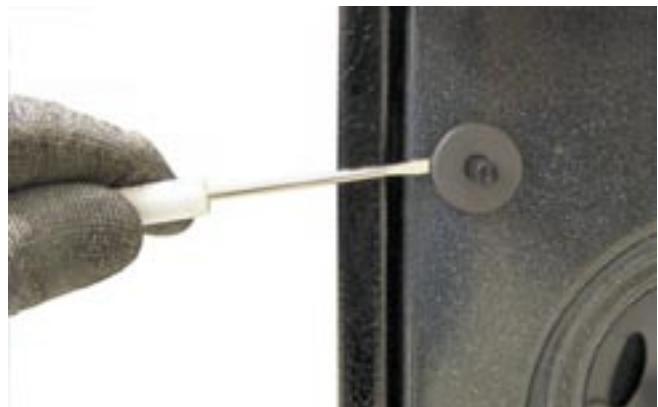

Oven Components and Replacement

Oven Burner Ignition System

The oven bake and broil burners are ignited by a glow-bar ignition system. The igniter is a *Norton* style rectangular glow-bar. The bake and broil ignition circuits consist of the electronic control, an igniter and an oven safety valve.

Note: The oven safety valve and pressure regulator will be supplied as a complete assembly, and is sometimes referred to as a gas valve, control valve, or a combi-valve.

The three components are wired in series for each cooking function.

The most important points to know about the ignition system are:

- THE IGNITER RESISTANCE DECREASES AS THE IGNITER SURFACE TEMPERATURE INCREASES.
- THE SAFETY VALVE OPERATES BY CURRENT, NOT VOLTAGE.

From a cold start, the igniter needs 30 to 60 seconds, with a minimum of 116 volts applied, to reduce its electrical resistance enough to provide a minimum of 2.9 amps of current flow in the series circuit. This is the required current flow needed for the safety valve to open and supply gas to the burner.

The glow-bar should provide a steady current flow of between 3.3 to 3.6 amps (3.03 / 3.3 VAC) in the circuit. At that point the igniter temperature is between 1800°F to 2500°F (982°C to 1371°C). The igniter will remain energized at all times during burner operation. If the igniter glows red but does not draw at least 2.9 amps, the fault is usually with the igniter, not the valve.

Always check the gas shut-off valve on the pressure regulator for a *Not On* condition.

Glow-bar Igniter

WARNING: This range uses rectangular *Norton* glow-bar igniters. They are NOT INTERCHANGEABLE with cylindrical *Carborundum* glow-bar igniters. The two types of glow-bar igniters operate at different amperage and use different gas valves.

Check the glow-bar circuit with a clamp-on ammeter. If igniter glows red but circuit does not draw at least 2.9 amps, the fault is likely with the igniter, not the valve.

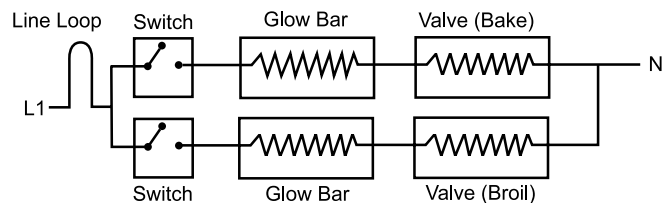

Note: If igniter glows, but ignition does not occur, be sure the gas shut-off valve on the pressure regulator is in the open position.

Slow ignition can be caused by one or more of the following conditions:

1. Blockage of primary air intake: Hole beneath the bake orifice hood must be open and free of insulation.
2. Improper alignment of orifice hood and burner: Orifice must be pointing straight into burner venturi.
3. Improper air/gas adjustment.
4. Blockage of burner crossover slots: Crossover slots must be open and free of burrs.
5. Improper installation: Failure to seal all openings in the wall behind and floor below range may permit substantial drafts which can affect ignition.
6. The gas control valve should draw approximately 3.3 to 3.6 amps when operating. Check by measuring the amperage in L1 to the oven control.

Broil Burner and Glow-bar Igniter

To remove the broil burner and glow-bar igniter:

1. Remove the oven door (See *Oven Door*).
2. Remove the screw that holds the burner in place. Lower the burner.

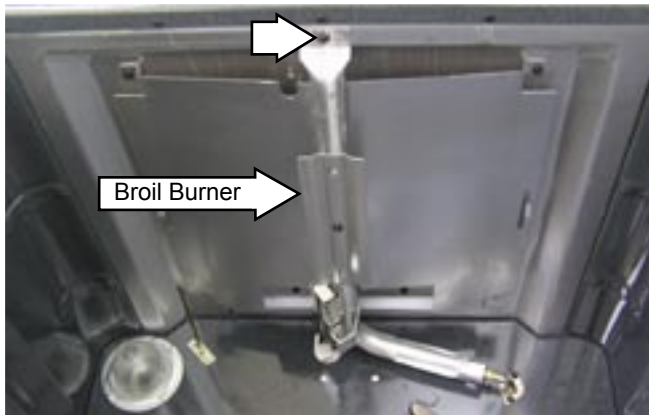

3. Remove the 2 hex-head screws that hold the glow-bar igniter to the burner.

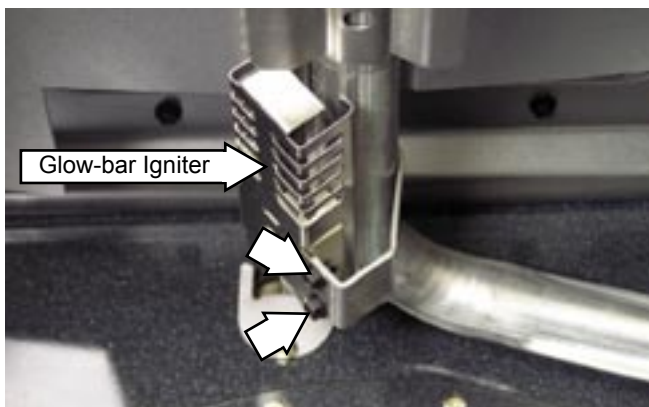

4. Remove the burner.

Note: When reinstalling the burner, be sure the tab on the burner is inserted into the slot on the rear wall of the oven. Make sure the orifice hood is inserted into the burner inlet opening.

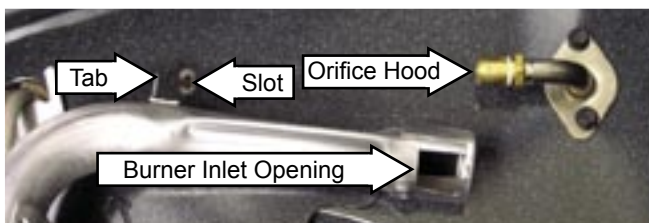

5. Remove the access cover from the back of the range and disconnect the glow-bar igniter connector.



6. Remove the wire retainer and gently pull the glow-bar connector through the oven wall and remove the glow-bar igniter from the oven.

IMPORTANT: When reinstalling the glow-bar, the connector end must be positioned **OUTSIDE** the range insulation. Do not allow the connector next to or inside the insulation. Allow the stiff over sleeve to position the connector away from the insulation.

Insulation should be allowed to close in around the igniter lead wires thus protecting the connector from any heat loss at the insulation opening.

Bake Burner and Glow-bar Igniter

To remove the bake burner glow-bar igniter:

1. Remove the oven door (See *Oven Door*.)
2. Remove the warming drawer (See *Warming Drawer*.)
3. Remove the bottom pan by removing 2 screws, lifting the back of the pan, and sliding the pan back until it can be removed from the oven.

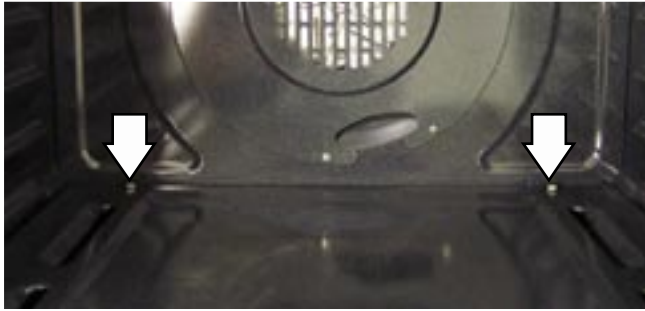

4. Remove the 2 hex-head screws that hold the glow-bar igniter to the bake burner.



5. Disconnect the glow-bar igniter wires located behind the warming drawer. Gently pull the connector through the oven floor and remove the glow-bar igniter from the oven.



6. Remove the hex-head screw that holds the front of the burner in place.

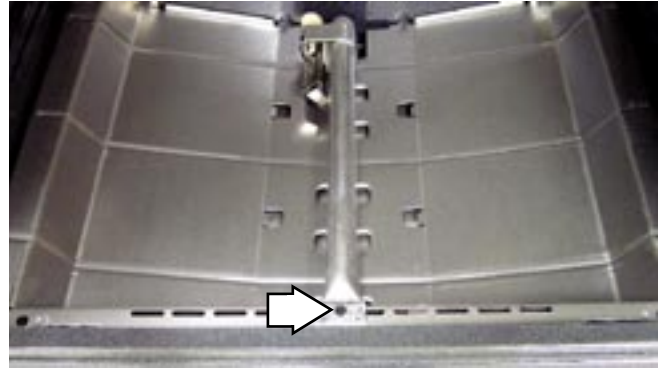

7. Remove the 2 hex-head screws, located behind the warming drawer, that hold the burner in place and remove the burner.

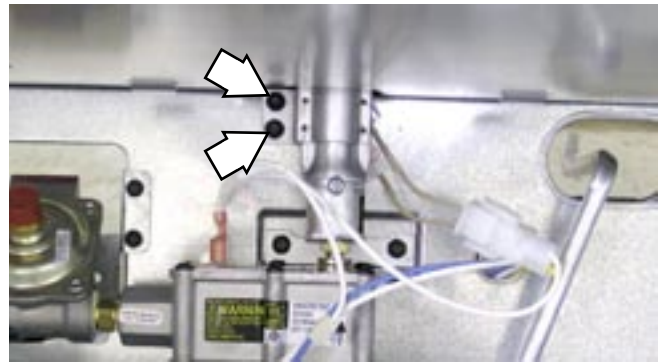

Note: When reinstalling the bake burner, be sure the orifice hood is inserted into the burner inlet opening.

Bake and Broil Burner Flame Adjustments

WARNING: Adjustments require disassembly of the burner section. To prevent handling hot parts, oven should be cool.

Note: A small amount of odor is normal and will be present when the range is first turned on. If there is a strong odor, the bake and broil burner assemblies should be inspected.

Bake and Broil Burner Test

1. Remove the oven door (See *Oven Door*.)
2. Remove the bottom pan (See *Bake Burner and Glow-bar Igniter*.)
3. Reinstall the oven door.
4. Close the oven door, set the control for **BAKE**, and observe the bake burner flame.
5. Observe the flames for a period of at least 2 minutes. The flame should not lift or blow off the burner during any period of operation. It should be blue with approximately a $\frac{1}{2}$ -in. to $\frac{3}{4}$ -in. (12-mm to 19-mm) inner cone.

Inner Cone of Flame

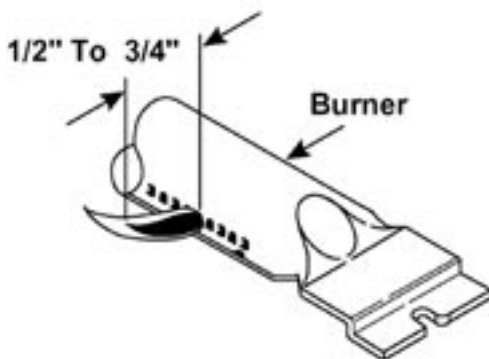

6. Set the control for **BROIL** and repeat step 5.

Note: The door should remain closed during this test.

To correct any flame problems, perform the following procedures:

Bake Burner

1. Remove the warming drawer (See *Warming Drawer*.)
2. Closely examine the angle of the orifice. The orifice must point straight into the burner.
3. Use a screwdriver to loosen the air shutter screw.

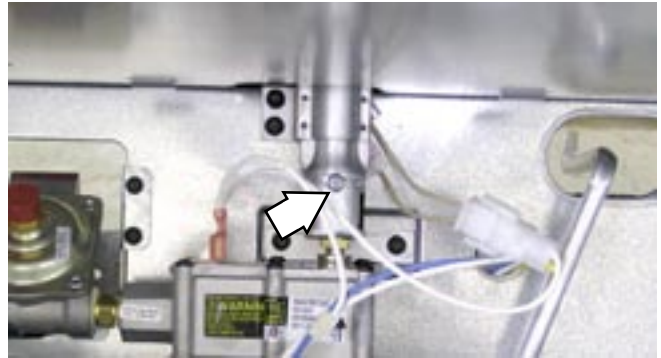

4. Adjust the air shutter to $\frac{11}{32}$ in.
 - a. If the flames were yellow during the test, open the air shutter an additional $\frac{1}{32}$ in. (0.79 mm.)
 - b. If the flames blow away or fluttered from the burner during the test, reduce the air shutter an additional $\frac{1}{32}$ in. (0.79 mm.)

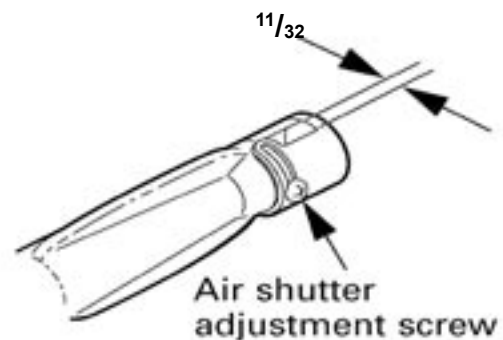

5. Retighten the air shutter screw.
6. Install the oven door. Before installing the bottom pan, set the control for **BAKE** and observe the bake burner flame for any flame problems.
7. Install the bottom pan. With customer present, test oven from a cold start to be sure any odor problems have been corrected.

Broil Burner

The broil burner is accessible and located in the top center of the oven.

1. Remove the oven door (See **Oven Door**.)
2. Remove the broil burner (See **Broil Burner and Glow-bar Igniter**.)
3. Closely examine the angle of the orifice. The hood must point straight into the burner.

The angle can be corrected by using a small adjustment wrench clamped loosely over the orifice to bend the orifice and its mounting assembly as needed.

4. Inspect the primary air opening. The opening must be clear all the way down to the metal shield below (0.314 in. opening.)
5. Use a screwdriver to loosen the air shutter screw.
6. Adjust the air shutter to $1\frac{1}{32}$ in.
 - a. If the flames were yellow during the test, open the air shutter an additional $\frac{1}{32}$ in. (0.79 mm.)
 - b. If the flames blow away or fluttered from the burner during the test, close the air shutter an additional $\frac{1}{32}$ in. (0.79 mm.)

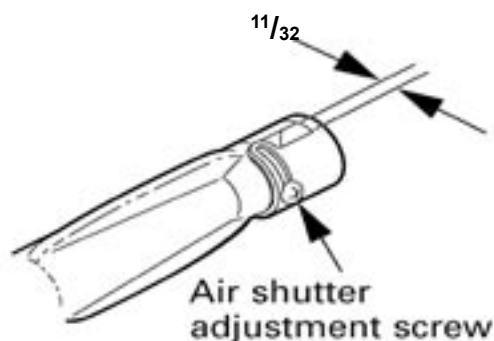

7. Retighten the air shutter screw.
8. Install the oven door. Set the control for **Broil** and observe the broil burner flame for any flame problems.
9. With customer present, test oven from a cold start to be sure any odor problems have been corrected.

LP and Natural Gas Information

LP Gas Installations: If flames lift off the burner and appear unstable, reduce the air shutter openings an additional $\frac{1}{32}$ in. (0.79 mm), cool the oven, and perform the *Bake and Broil Burner Test*. If flames are too large but appear stable, check to be sure the oven was properly converted.

Natural Gas Installations: If flames are too large but appear stable, tighten the orifice hood to reduce the gas flow to the burner.

Convection Fan Motor

To remove the convection fan motor:

1. Remove the oven door (*See Oven Door.*)
2. Remove 6 Phillips-head screws that secure the convection fan guard to the rear wall of the oven. Remove the convection fan guard.

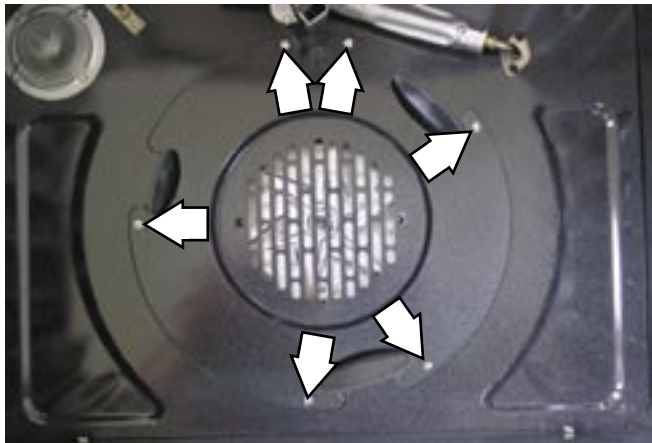

3. Using a 1/2-in. wrench, remove the nut from the convection fan blade by holding the blade securely and turning the nut clockwise.

Note: Convection fan blade nut has left-handed threads.



4. Remove the fan blade and washer from the fan motor shaft.

5. Remove the 4 Phillips-head screws that secure the motor plate to the rear of the range and remove the motor assembly.

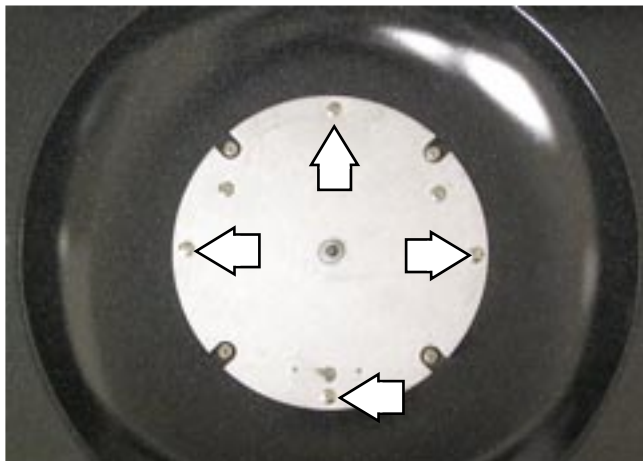

6. Disconnect the 3 wire connectors from the motor.
7. Remove the 6 mounting Phillips-head screws and the motor.

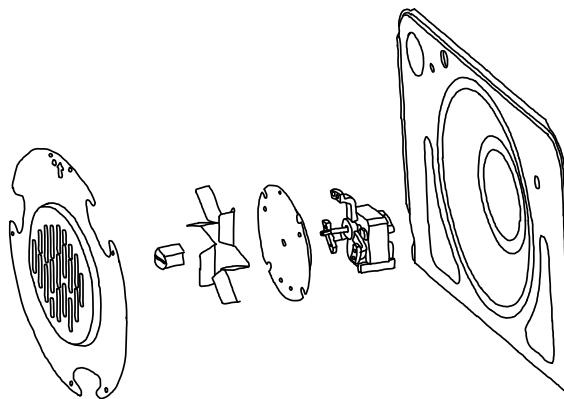
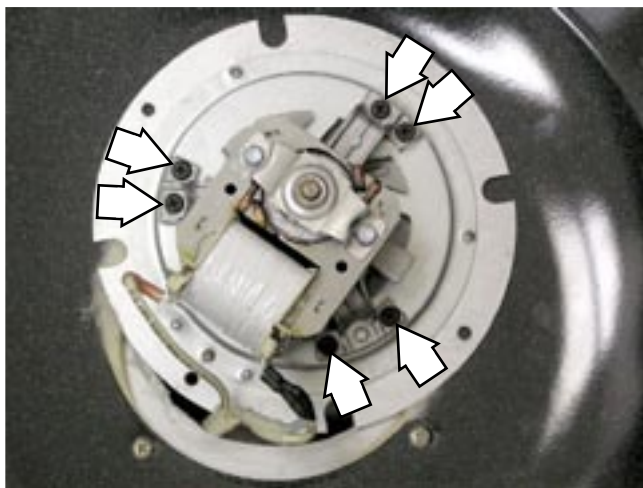

Meat Probe Outlet

The meat probe outlet is located near the top left corner of the oven cavity. To access the probe, open the oven door and remove the 2 Phillips-head screws that secure the probe outlet to the oven.



The outlet and wiring can then be pulled down from the oven wall approximately 1½ inches.

Note: When replacing the meat probe outlet, cut the probe wires and splice the new probe using approved heat resistant connectors.

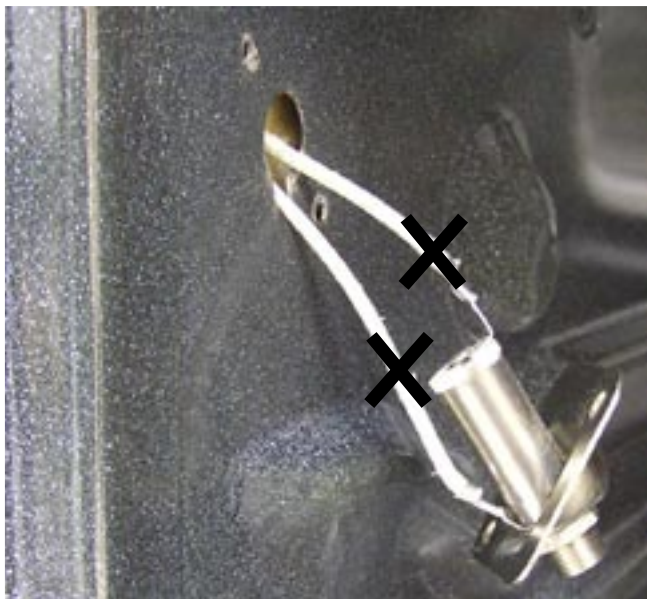

Oven Temperature Sensor

To remove the temperature sensor:

1. Remove the oven door. (See *Oven Door Removal*.)
2. Remove the range from the installation.
3. Remove the two ¼-in. hex-head screws that attach the wiring cover to the rear of the range.



4. Disconnect the sensor wire harness.

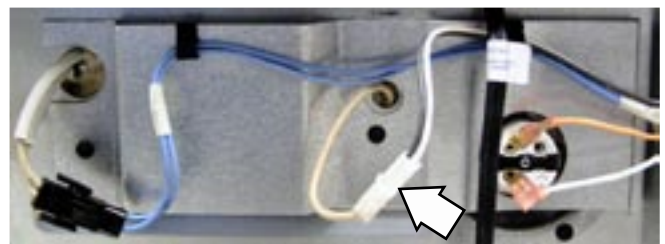

5. Remove the two ¼-in. hex-head screws that hold the sensor to the rear wall of the oven cavity.



6. Gently pull the sensor wire harness into the oven.



Note: When reinstalling the sensor, use a small flat-blade screwdriver to push and guide the sensor wire harness into the oven liner.



IMPORTANT: When reinstalling the oven temperature sensor, the connector end must be positioned **OUTSIDE** the range insulation. Insulation should be allowed to close in around the oven temperature sensor lead wires thus protecting the sensor from any heat loss at the insulation opening.

Safety Valve and Pressure Regulator

WARNING: Before servicing the range, power and gas must be removed from the range. Make sure the oven is completely cool.

Note: The safety valve and pressure regulator are a "combi-valve" and are removed and replaced as an assembly.

The combi-valve is front serviceable. The amperage should be between 3.3 to 3.6 amps at 3.0 to 3.3 VAC.

To replace the combi-valve:

1. Remove the oven door (See *Oven Door*.)
2. Remove the warming drawer (See *Warming Drawer*.)
3. Remove the bake burner (See *Bake burner and Glow-bar Igniter*.)
4. Remove the gas line connections indicated below, note the wiring locations, and disconnect the wiring.
5. Remove the hex-head screws that hold the combi-valve in place.
6. Remove the combi-valve.

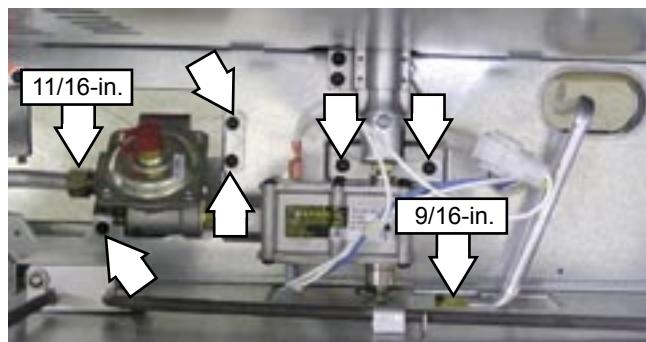

Control Panel Assembly

Control Panel

To remove the control panel:

1. Move the range approximately 4 inches out from its installation.
2. Loosen (do not remove) the two ¼-in. hex-head screws located at the top rear corners of the backguard.



3. Remove the two T-15 Torx screws that attach the bottom of the control panel to the backguard.



Caution: To prevent damage to control panel, place a piece of cardboard or other protective item over the surface burner grates.

4. Grasp and pull the bottom of the control panel out approximately 1 inch and lift it off the top rear corner screws.



5. Carefully support and position the control panel on the burner grates in the service position.



Service Position

Caution: To prevent damage to porcelain finished components, do not overtighten screws.

Spark Module

The spark module is located inside the backguard and is held in place by 2 tabs, 1 on each side. To access the spark module, it is necessary to place the control panel in the service position. (See **Control Panel**.) The module can be removed by pressing either tab inward. Mark and note wire locations before disconnecting the module.

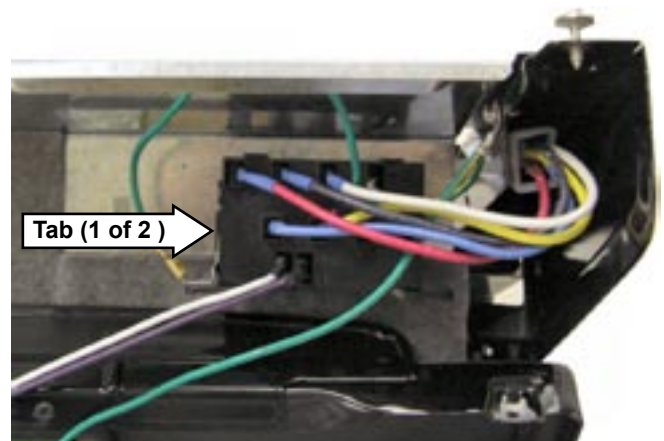

Electronic Range Control (ERC)

The electronic range control (ERC) is located inside the backguard and is attached to the control panel with 4 Phillips-head screws, 2 on each side. To access the ERC, it is necessary to place the control panel in the service position. (See **Control Panel**.) Mark and note wire locations before disconnecting the ERC.

Note: When installing the ERC make sure the insulation barrier is secured under the bottom 2 Phillips-head screws and the plastic wire tie and ground wire are returned to their original positions.

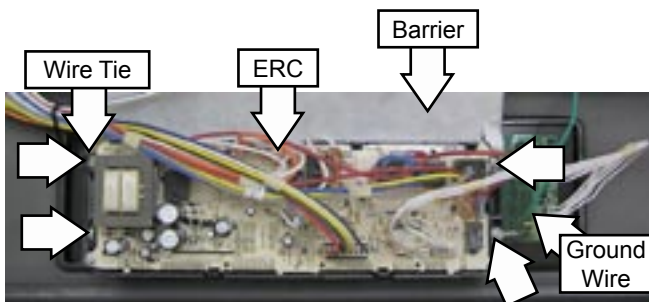

Control Panel and Touch Board

The control panel and touch board will be supplied as a complete assembly. If the touch board is damaged or defective, the entire control panel assembly must be replaced.

To replace the control panel and touch board, it is necessary to place the control panel in the service position. (See **Control Panel**.) The ERC must be removed (See **Electronic Range Control (ERC)**.) and the wire harness disconnected from the touch board.

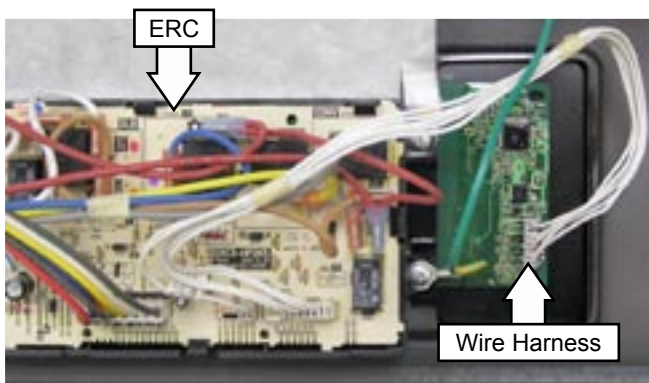

Range Top Components and Replacement

Maintop Burner Assembly

WARNING: Shut off gas to the range before proceeding.

Each maintop burner assembly consists of the burner cap, burner head, bracket, orifice, and tube. To improve alignment and stability, the five burner brackets have been mounted to the under side of the cooktop using “T-15” Torx screws.

To remove the maintop burner assembly:

1. Remove the Maintop. (See *Maintop*.)

Note: If removing the left front or left rear burner assemblies, omit step 2.

2. Remove the two ¼-in. hex-head screws that attach the shield to the top right side of the manifold panel.
3. Pull the ignitor wire out of the wire inlet in the bracket.
4. Using a 5/8-in. socket and extension, remove the nut that holds the bracket to the inlet tube then lift the bracket off the tube.
5. Remove the ½-in. nut that holds the inlet tube to the valve.

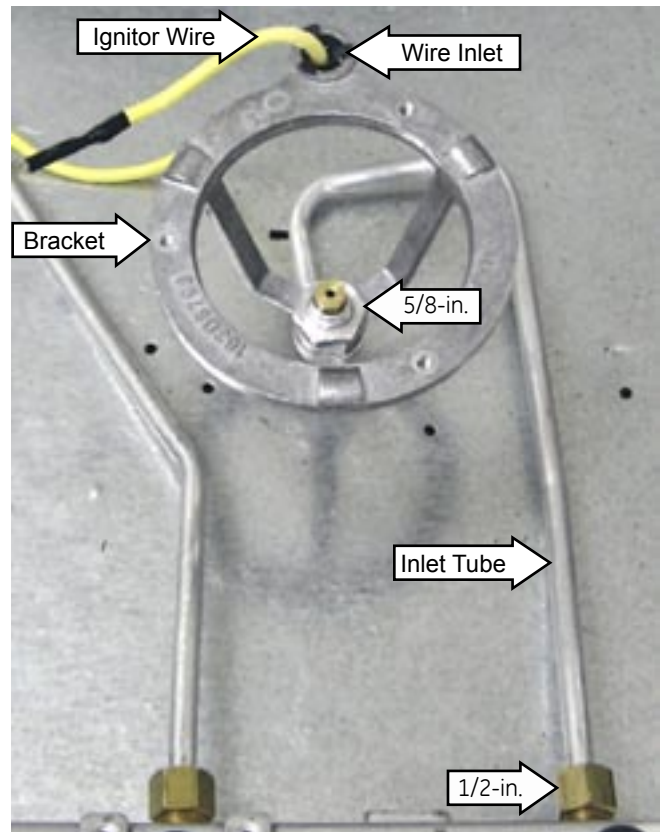

Maintop Burner Alignment

For proper operation of the burner, alignment of the orifice holder, orifice, and air/gas mixer tube must be correct. The alignment can be checked by placing 7-mm or $\frac{9}{32}$ -in. nut-driver over the orifice to exaggerate the angle. The nut-driver should stand straight, indicating the alignment and gas injection angle is correct. A slight downward pressure may be necessary to seat the nut-driver over the orifice-retainer ring.

If an angle adjustment is necessary remove the burner cap, head, and bowl to inspect the orifice holder and the brackets that hold them in place. Adjust as necessary by carefully bending the supply tube. A misaligned burner may result in uneven flames around the burner head.

Maintop Burner Flame Adjustments

The top burners do not have air shutters and fixed, non adjustable orifices are used. If the flames blow off the burner or have yellow tips, check the following:

- Gas pressure: 5" Natural gas 10" LP gas.
- Inspect orifice to be sure it is drilled on center and free of debris or burrs.
- Be sure the correct size orifice is in the proper location (see "Orifice Identification" section of this sheet).
- Make sure the range was properly converted if on LP gas.

Low Flame Simmer Adjustments

Remove the surface control knob and locate the adjustment screw in the center of the control valve shaft. A thin flat-blade screwdriver, approximately $\frac{3}{32}$ -in. across, is needed to access the screw. Turn the adjustment screw until the flame reaches the desired size.



Note: Low setting adjustments must be made with 2 other burners in operation on a medium setting. This procedure prevents the low flame from being set too low, resulting in the flame being extinguished when other burners are turned on.

Testing the Flame Stability

Test 1: Turn the knob from **HI** to **LOW** quickly. If the low flame goes out, increase the flame size and test again.

Test 2: With the burner on **LOW** setting, open and close the oven door quickly. If the flame is extinguished by the air currents created by the door movement, increase the flame height and test again.

Test 3: With 2 burners on **HIGH** setting, set a third adjusted burner on **LOW**. Turn the first knob from **HI** to **LOW** quickly. The third burner should stay lit.

Manifold Panel

To remove the manifold panel:

1. Remove the oven door. (See *Oven Door Removal*.)
2. Remove the main top. (See *Main Top Removal*.)
3. Remove the surface burner valve knobs by pulling each knob straight out.
4. Remove the two ¼-in. hex-head screws that attach the shield to the top right side of the manifold panel.
5. Remove the 2 Phillips-head screws and the 2 guides from the main top.
6. Remove the 4 Phillips-head screws that hold the front of the manifold panel to the gas manifold.

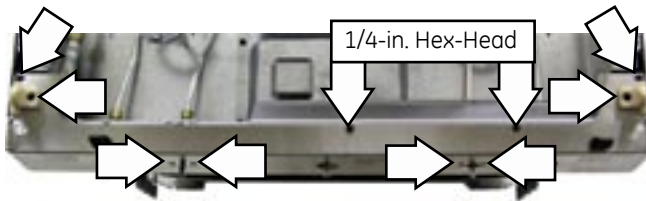

7. Remove the three ¼-in. hex-head screws from the bottom of the manifold panel.



8. Pull the manifold panel straight out from the range.

Maintop Burner Valves

The maintop burner valves are located inside the manifold panel and are attached to the gas manifold by a single screw.

To remove the burner valve:

1. Remove the manifold panel. (See *Manifold Panel*.)
2. Turn off the gas supply to the range.
3. Using a ½-in. open-end wrench disconnect the burner inlet tube from the valve.
4. Remove the ¼-in. hex-head screw that holds the burner valve to the gas manifold. Lower the valve from the gas manifold.
5. Remove the protective cover from the valve stem.
6. Remove the ignitor switch from the valve. (See *Ignitor Switches*.)

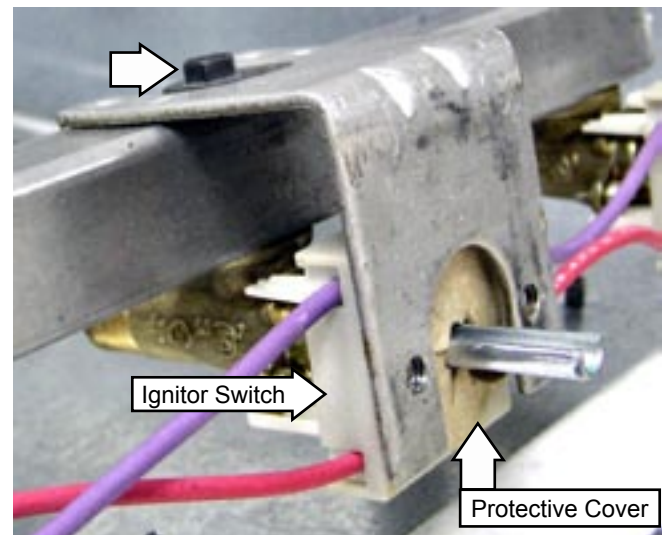

Caution: Ensure the valve seal and the screw seal are in place BEFORE installing the valve.

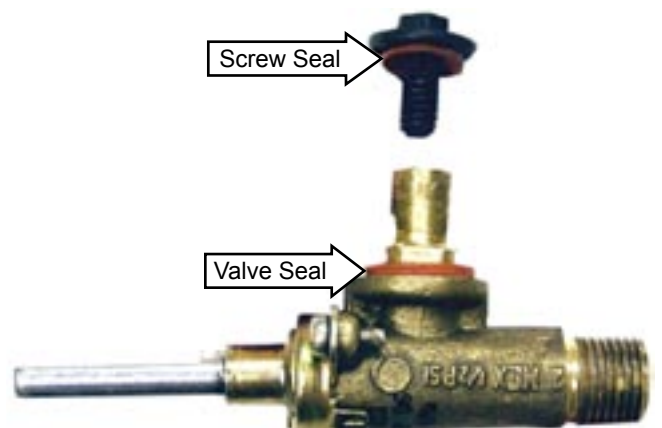

Ignitor Switches

The ignitor switches are located inside the manifold panel and are attached to each maintop burner valve. The back of each switch is molded to conform to the front of the burner valve and is locked in place by 2 tabs. All switches are wired to a single harness and can be replaced separately.

Note: To replace the ignitor switch for the left or right rear burner, it is necessary to remove the left or right rear burner valve from the gas manifold.

To remove the ignitor switch:

Caution: The 2 lock tabs on each ignitor switch are fragile. Tab breakage can occur if excessive release pressure is applied.

1. Remove the manifold panel. (See **Manifold Panel**.)

Note: When replacing the ignitor switch for the left or right rear burner, remove the valve from the gas manifold. (See **Maintop Burner Valves**, follow steps 2 through 4.)

2. Remove the protective cover from the valve stem.
3. Using a small flat blade screwdriver, carefully pry on the 2 release tabs and slide the switch off the valve stem.

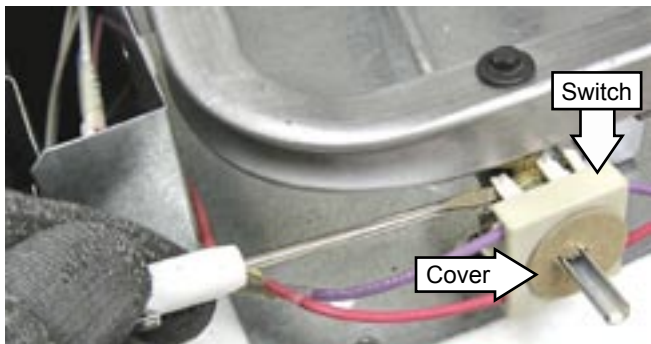

Note: When replacing an ignitor switch, cut the switch wires and splice the new switch using approved connectors and heat shrink tubing.

Gas Manifold

WARNING: Shut off gas to the range before proceeding.

To remove the gas manifold:

1. Remove the Maintop. (See **Maintop**.)
2. Remove the two ¼-in. hex-head screws that attach the shield to the top right side of the manifold panel.
3. Remove the ½-in. nut that holds the inlet tube to each valve.
4. Using a 1³/₁₆-in. open-end or adjustable wrench, disconnect the gas inlet tube from the gas manifold.
5. Remove the left and right rear burner knobs then remove the 4 Phillips-head screws from the front of the manifold panel.
6. Remove the two ¼-in. hex-head screws that attach the gas manifold to the range.



7. Remove the 5 burner valves from the gas manifold. (See **Maintop Burner Valves**.)

Door Latch Assembly

The door latch assembly consists of a lock motor, cam and switch assembly, lock hook, and mounting plate. It will be supplied as a complete assembly. The door latch assembly is located under the main top in a recess that is concealed by a metal cover.

To replace the door latch assembly:

1. Remove the oven door. (See *Oven Door Removal*.)
2. Remove the main top. (See *Main Top Removal*.)
3. Remove the two ¼-in. hex-head screws that attach the shield to the top right side of the manifold panel.



4. Remove the four ¼-in. hex-head screws that hold the latch assembly cover in place. Remove the cover.

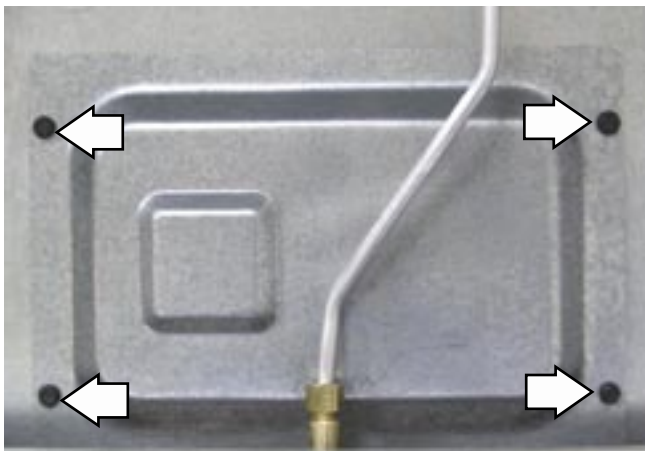

5. Mark and disconnect the wiring from the latch assembly.

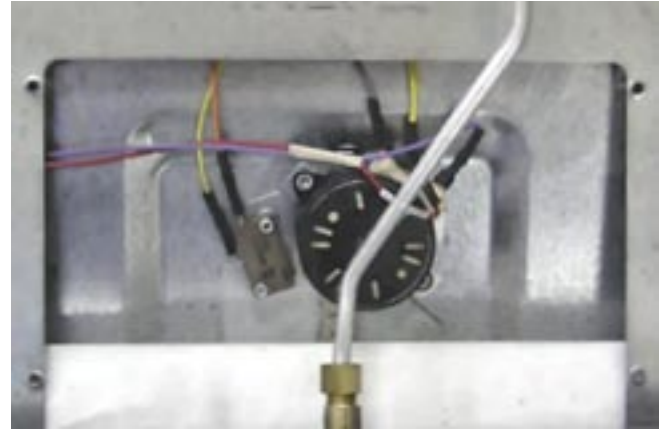

6. Remove the 2 T-15 Torx screws that attach the latch assembly to the frame and slide the assembly out of the recess.

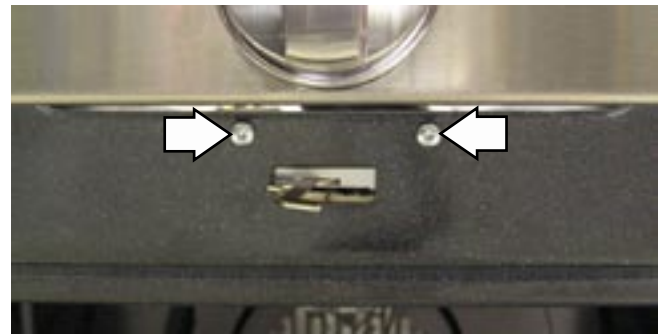

Diagnostics and Service Information

Conversion to LP (PROPANE) Gas

1. **Convert Regulator** - Regulator is located in the lower, left hand rear corner of the range as viewed from the front.

a) To access the regulator, remove the warming drawer. (See **Warming Drawer**.)

b) Remove the large hex-nut which is located in the center of the regulator. Remove the plastic pin from the bottom side of the cap, turn the pin 180 degrees and snap the pin back into the cap. There are raised letters on the flat side of the plastic pin, "NAT" and "LP". In the "LP" position the end of the pin marked "NAT" should be snapped into the bottom of the hex-nut.

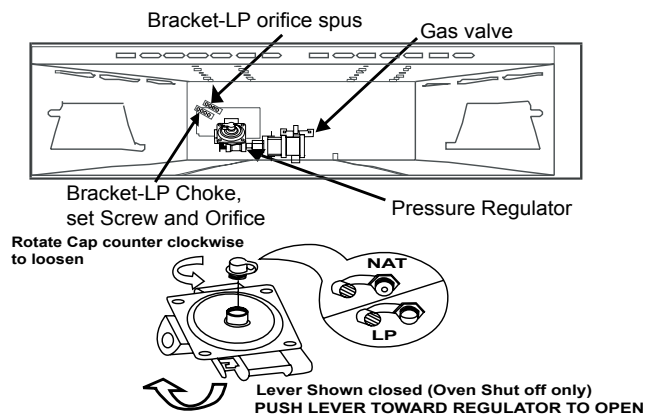

2. Converting the surface burners

a) LP orifice spuds are located at the back of the warming drawer compartment. The spuds are in a metal bracket next to the pressure regulator and are attached to the back wall of the compartment by a 1/4-in. hex head screw. An LP conversion instruction sheet is also located in this area. (See above picture)

b) Removed grates, burner caps, and burner heads.

c) Remove the brass orifice spud in the chimney of each burner using a 3/32-in. or 7-mm nut driver. The top burner orifices can be removed by removing the burner caps and burner heads. Use 7 millimeter nut driver to access the orifice.

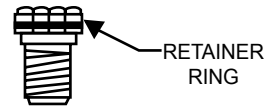

NOTE: The orifices have spring loaded retaining rings around the hex head to hold the orifice in the nut driver during installation and removal. A slight amount of force is required to push the nut driver down over the ring.

d) Install the LP orifice spuds into their correct positions as described as follows. A series of marks (I; II or III) are engraved on the top of the orifices to denote the location of the orifice as shown in the illustration. The marks appear on both the LP and Natural Gas orifices. The locations indicated by the marks are the same for both gasses.

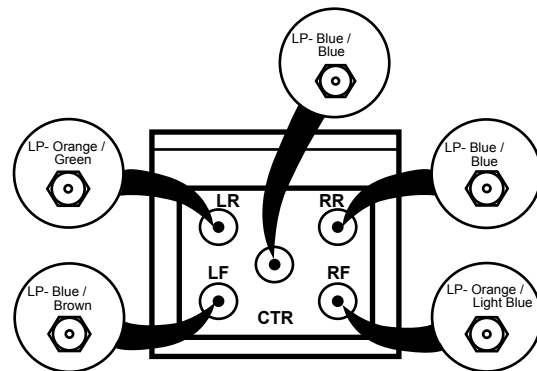

To aid in identifying the proper location for the LP orifices during a conversion from Natural Gas to LP Gas, paint color codes have been added to the side or top of the orifice. See the chart below.

LP ORIFICE COLOR ID		
Burner	BTU Rate	Color
RF	10,000	Orange / Light Brown
LF	9,500	Blue / Brown
LR	9,100	Orange / Green
RR	5,000	Blue / Blue
CENTER	5,000	Blue / Blue

(Continued next page)

e) To prevent leakage, make sure the orifice spuds are securely screwed into the gas supply tubes.

f) For the extra large burner (right front), the choke and self threading screw will be needed. Insert the choke into the burner base, then insert the set screw into the burner base and tighten securely. Make sure the screw head is against the shoulder (within the choke notch), so it does not have any rotational movement.

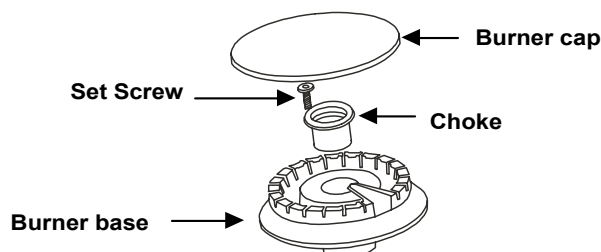

g) Install the old NG orifice spuds into the metal bracket and place back on the range for possible future conversion.

BURNER OUTPUT RATINGS; BTU/HR		
Natural Gas, 5" W.C.P		
BURNER	BTU RATE	ORIFICE SIZE
RF	16,500	0.0755" (1.92mm)
LF	11,000	0.061" (1.55mm)
LR	9,100	0.0535" (1.36mm)
RR	5,000	0.0409" (1.04mm)
CENTER	5,000	0.0409" (1.04mm)
BAKE	16,000	#49 (.073")
BROIL	12,500	#52 (.0635")

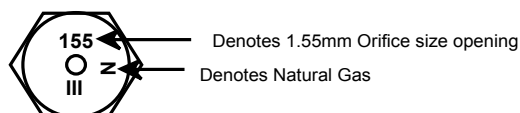

BURNER OUTPUT RATINGS; BTU/HR		
LP (Propane) Gas, 10" W.C.P		
BURNER	BTU RATE	ORIFICE SIZE
RF	10,000	0.0365" (0.92mm)
LF	9,500	0.035" (0.88mm)
LR	9,100	0.034" (0.86mm)
RR	5,000	0.025" (0.64mm)
CENTER	5,000	0.025" (0.64mm)
BAKE	16,000	#56 (.0465")
BROIL	12,000	#59 (.041")

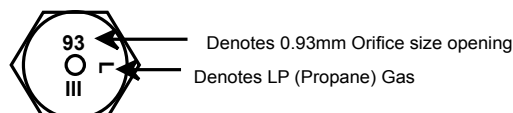

3. Converting the oven / broil burner orifices

a) Remove oven door, warming drawer and oven bottom. The oven burner orifice hood is located behind the warming drawer. The broil burner orifice hood is located on the right upper corner of the oven cavity.

b) To convert to LP, use a 1/2-in. wrench to turn the orifice hoods clockwise until it is snug with the base, approximately 2 1/2 turns. To prevent damage when converting back to Natural Gas, do not over tighten the hood.

c) Open the air shutter on the burners to the full open position and adjust as needed.

4. Check quality of the flames

The combustion quality of the burner flames needs to be determined visually.

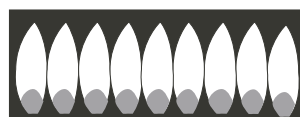

(A) Yellow Flames:
Further Adjustment Required



B) Yellow tips on outer cones:
Normal for LP Gas



(C) Soft Blue flames:
Normal for Natural Gas.

Note:

- If burner flames look like (A). Further air shutter adjustment is required. Normal burner flames should look like (B) or (C), depending on the type of gas you use. With LP gas, some yellow tipping on the outer cones is normal.
- The broil burner will cycle off when the sensor temperature reaches 460°F (238°C) set on Lo Broil, and at 570°F (299°C) set on Hi Broil.
- Upon completion of the conversion, fill out the LP sticker located with the instructions. Once complete, apply the sticker to the back of the range near the regulator. If converting back to natural gas from LP remove the LP sticker from the back of the range.

Oven Calibration

Testing has shown that this oven has the best cooking performance at a control setting of 350°F (177°C) when the average center oven temperature is between 350°F and 390°F (177°C and 199°C).

Customers may change the average center oven temperature by ± 35°F (± 2°C) to satisfy their own cooking needs.

To change:

1. Touch the BAKE and BROIL HI/LO pads at the same time for 3 seconds until the display shows SF.
2. Touch the BAKE pad. A number shows in the display. Touch BAKE once to decrease (–) the oven temperature, or twice to increase (+).
3. The oven temperature can be adjusted up as much as 35°F (2°C). or down as much as 35°F (2°C). Touch the number pads the same way you read them. For example, to change the oven temperature 15°F, touch 1 and 5.
4. When you have made the adjustment, touch the START pad to go back to the time of day display.

Note:

- The thermostat adjustment for baking will also affect Convection Baking or Convection Roasting.
- This adjustment will not affect the broiling or the self cleaning temperatures. The adjustment will be retained in memory after a power failure.

Lock Motor and Door Latch Switch Circuit Information

The lock motor circuit and the door latch switch circuit control the locking and unlocking of the door.

The lock motor is energized when the SELF CLEAN cycle is initiated with the door closed.

The lock motor circuit applies voltage (120 VAC) to the lock motor. This circuit is from the motor door lock relay (MDL location on ERC), to the lock motor, through the door switch to neutral.

For this circuit to be complete, the lock motor circuit must be energized by the ERC and the door must be closed. An open oven door results in **LOCKED** flashing in the display and alarm sounding after the control has been programmed for clean and **START** has been selected.

The door latch switch circuit signals the control if the lock motor is in the unlocked or locked position or somewhere in between (transition). There are 2 latch switches operated by the cam located below the lock motor.

The door latch switch circuit is from the ERC, through one of the latch switches (switch 1 for unlocked or switch 2 for locked) back to the ERC. If neither switch is closed, and the oven temperature is below 450°F (232°C) the ERC will energize the lock motor circuit until the correct switch closes to complete the circuit. (If circuit to the correct switch is open, the lock motor will run continuously with the oven below 450°F (232°C).

The cam on the motor performs two functions:

- Positions the lock hook in the door to prevent opening during the **CLEAN** operation.
- Operates the latch switches which tell the control if the door is unlocked or locked and ready for **CLEAN** operation.

Note: When the door is either being locked or unlocked, both latch switches will be in the open position.

The movement of the cam has also closed lock switch 2 which signals the control that the door is locked. The control then removes power from the lock motor circuit by de-energizing the lock relay.

The lock motor stops and lock switch 2 is held closed by the cam through the clean cycle.

The word **LOCKED** stops flashing and remains illuminated in the display.

The word **ON** remains illuminated in the display.

During the Clean Cycle the oven will cycle to maintain an average clean temperature of 815°F (435°C).

Clean Cycle and Lock Sequence:

1. Program the Clean Cycle:
 - Press **SELF-CLEAN** pad. 4 hours and 20 minutes (4:20), appears on the time display. (Cleaning time can be changed from the 4-hour 20 minute starting point by pressing the **SELF-CLEAN** pad a second time.)
 - After **START** has been pressed, the word **ON** illuminates in red and the word **LOCKED** flashes to indicate the cycle has begun.
2. Locking the Door:
 - After programming the clean cycle and pressing **START** pad, the control energizes the lock relay. Voltage (120 VAC) is applied to the lock motor circuit. Oven door must be closed before lock motor can run. **LOCKED** will flash and control will beep until the door is closed.
 - The lock motor begins to revolve and turns a cam mounted to the motor shaft.
 - The word **LOCKED** will flash on and off on the display while the lock motor is in motion.
 - As the cam revolves about $1/2$ revolution (approximately 12 seconds), it has moved the lock hook into a corresponding slot in the oven door which secures the door.

The words **LOCKED** and **ON** with the clean cycle time remaining will be displayed.

Door Unlocked

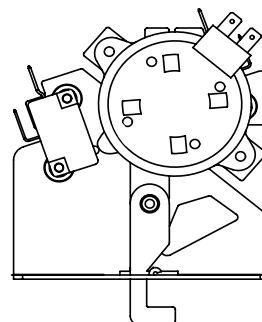

Door Locked

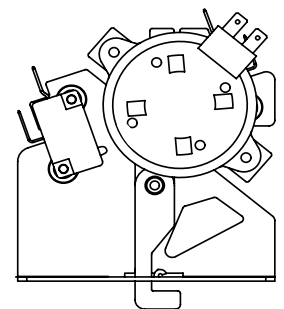

Service Test Mode

The sealed burner 30" gas range has a service test mode that can be utilized by the service technician in order to test certain oven components or functions. The selected components or functions will help the service technician to quickly identify failed or improper operation of the range.

Caution: Testing is accomplished through built-in test procedures. Unplugging components for testing can damage component connections.

The range must be powered down (unplugged) before entering test.

Test Mode Entry:

1. Power down the range for a minimum of 5 seconds.
2. Power up the range (all segments in the display and the control panel selections illuminate), and wait until the time of day is flashing.
3. Touch COOK TIME, DELAY START, and 8 simultaneously.
4. Display shows the word "test" on convection model or "save" on non-convection model.

Note: The test will time out in approximately 4½ minutes. Repeat test mode entry to continue.

Component or Function	Action
Sensor	Touch COOK TIME. The display will show sensor temperature in the temperature digits.
Bake	Touch BAKE then continuously touch START. The START key will initiate the bake cycle as long as the START key is touched.
Broil	Touch Broil HI/LO then continuously touch START. The START key will initiate the broil cycle as long as the START key is touched.
Convection Fan LO Speed*	Touch continuously CONV. ROAST. The fan will operate at lo speed in a CW direction with door shut as long as CONV. ROAST key is touched.
Convection Fan HI Speed*	Touch continuously CONV. BAKE. The fan will operate at hi speed in a CW direction with door shut as long as CONV. BAKE key is touched.
Self Clean	Touch continuously the SELF-CLEAN key. This action will energize the Door Motor relay, and display the door inputs in select decimal format in the temperature center digit. 0 = Transition - Locked icon blinks 1 = Unlocked - No icon 2 = Locked - Locked icon solid
Warming Drawer	Touch WARMING DRAWER SET/OFF then continuously touch START. The START key will initiate the warming drawer cycle as long as the START key is touched.
PROBE*	Touch PROBE. The display will show 99°F with probe out (or probe temperature with probe plugged in), and the word PROBE.
Clock	Touch CLOCK. The display will show a defined pattern.
Start	Touch START. The display will show the ON word and flash the SET word (unless a relay type has been previously touched)
Digits	Touch a number. The number selected will be displayed.

* Convection model only

Failure Codes and Component Testing

The oven may stop operating but not give an F code on the display immediately. Generally, a fault must exist continuously for 5 minutes before an F code is recorded (F2 is sooner). F codes are stored in nonvolatile EEPROM memory until the same fault occurs twice consecutively. After that, the F code will be displayed. F codes can be recalled by pressing together **TIMER, CLOCK, 9**.

FAILURE CODE MEANINGS & CORRECTIONS

FAILURE CODE	MEANING	EXPLANATION
F0	CLEAR/OFF key input failure	Short for approximately 100 seconds
F1	Control failure	Loss of element relay redundant driver protection
F2	Oven temperature condition due to sensor input to control	Oven above 615°F with lock input untrue. Oven above 915°F with lock input true
F3	Open sensor	Sensor is 2900 to infinite ohms while in a heating mode.
F4	Shorted sensor	Sensor is 0 to 950 ohms maximum while in a heating mode
F6	START key input failure	Shorted START key detection
F7	Shorted key detection except for slew entry and CLEAR/OFF keys	Short for approximately 40 seconds
FC	Door latch error	Unlock home and lock home are true simultaneously
FD	Probe failure	Shorted probe
FF	Control failure	Loss of door motor redundant driver protection

Notes:

- Multiple fault codes may be displayed.
- The latest fault code will appear on the right of the display.
- While F codes are displayed, pressing **8** and **6** together will clear the codes from the memory.
- Clear the fault code after the failure has been corrected.

Key Panel Test

The key panel and ERC are separate components but must be tested together.

Press each pad on the key panel followed by the start pad. If the key panel is functioning properly, the following should occur:

- **BAKE**, (**CONV. BAKE** and **CONV. ROAST**, if available), **BROIL HI/LO**, **COOK TIME**, **DELAY START**, **WARMING DRAWER SET/OFF**, **SELF CLEAN**, **CLOCK**, **TIMER ON/OFF**, and **CONTROL LOCKOUT** Modes - Audible tone plus display showing mode of operation selected.
- **CLEAR/OFF** - Audible tone and display shows time of day.
- **PROBE** - Audible tone and response if meat probe is plugged in (convection model).
- **Numerical Pads** - Audible tone. Can only be used after another function has been selected.

ERC Test Locations - Convection Model

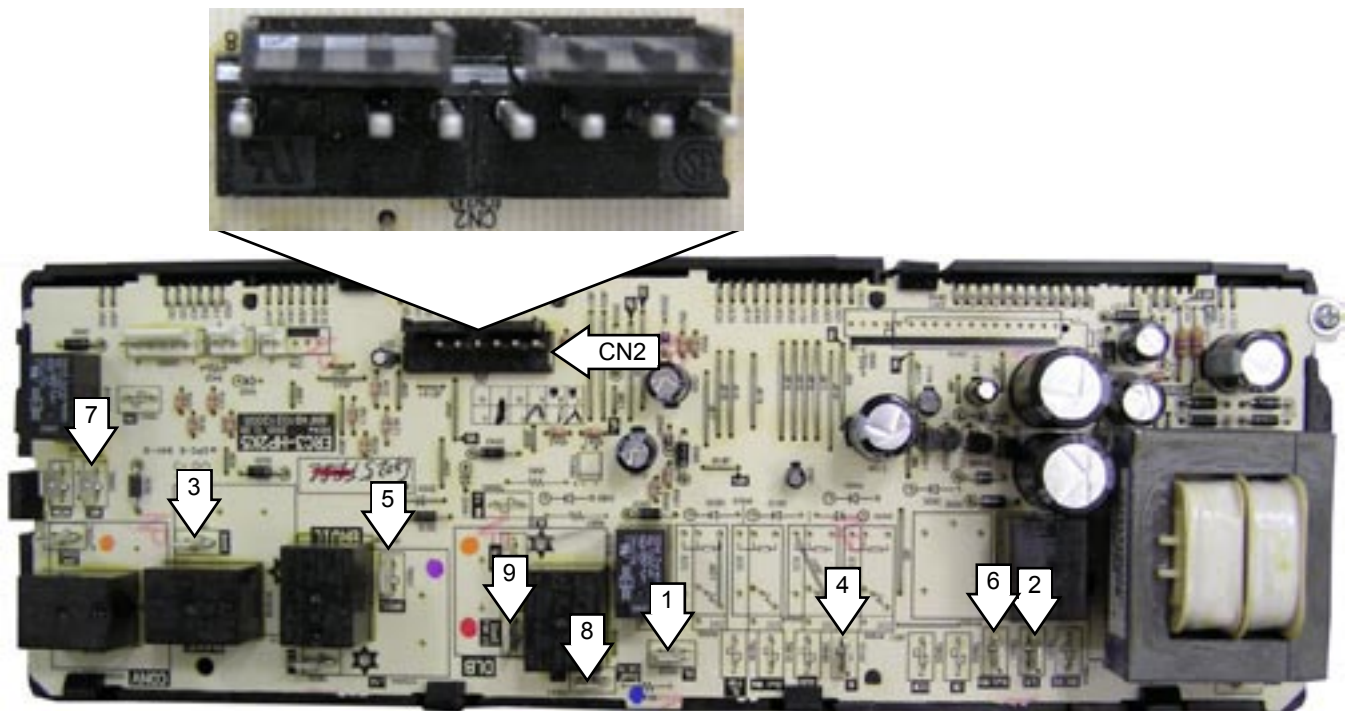

1 - Oven Light

2 - Line

3 - Bake

4 - Neutral

5 - Broil

6 - Warming Drawer

7 - Lock Motor

8 - Convection Fan Hi

9 - Convection Fan Lo

CN2 - Pin 1 - Probe

Pin 2 - GND (Ground)

Pin 3 - Unlock (Latch Switch #1)

Pin 4 - Lock (Latch Switch #2)

Pin 5 - Common

Pin 6 - VDD (Sensor)

Pin 8 - Oven (Sensor)

ERC Test Locations - Non-Convection Model

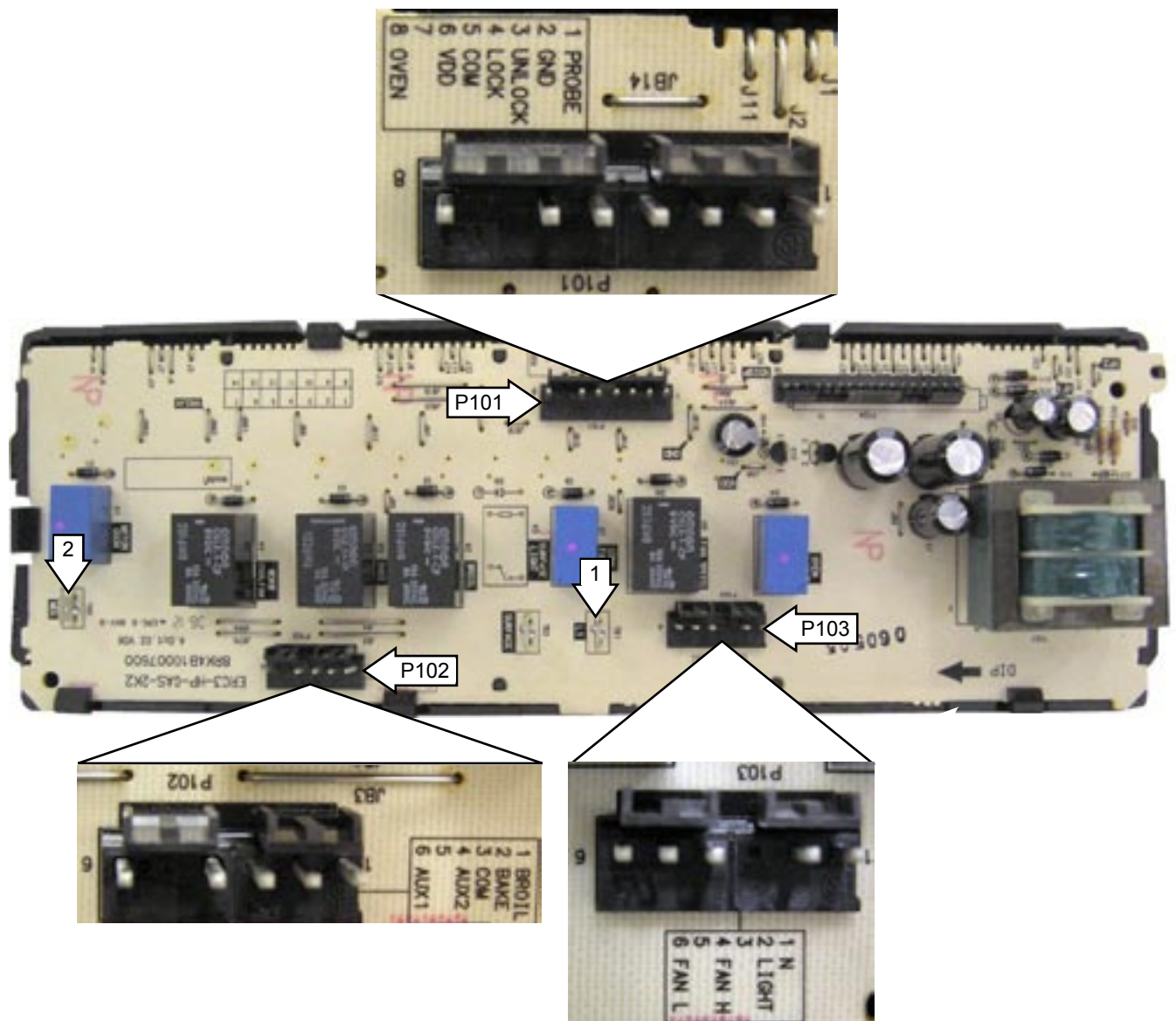

1 - L1 - Line

2 - MDL - Lock Motor

P101 - Pin 3 - Unlock (Latch Switch #1)

Pin 4 - Lock (Latch Switch #2)

Pin 5 - Common

Pin 6 - VDD (Sensor)

Pin 8 - Oven (Sensor)

P102 - Pin 1 - Broil

Pin 2 - Bake

Pin 3 - Common (L1)

Pin 4 - Aux2 (Warming Drawer)

P103 - Pin 1 - N - Neutral

Pin 2 - Light (Oven Light)

Component Resistive Testing

WARNING: Disconnect electrical power before servicing.

Caution: Label all wires prior to disconnection. Wiring errors can cause improper and dangerous operation. Verify operation after servicing.

Note: Resistance values in the following table are approximate.

Component	Test Locations		Conditions	Resistance
	Convection	Non-Convection		
Oven Light	OL to L1	P103-2 to L1	None	25 Ohms
Bake Glow Bar	Bake to N	P102-2 to P103-1	None	124 Ohms*
Broil Glow Bar	Broil to N	P102-1 to P103-1	None	164 Ohms*
Warming Drawer Element	WD OUT to N	P102-4 to P103-1	None	32 Ohms
Latch Motor	MDL to N	MDL to P103-1	Door closed	1.97K Ohms
Fan Motor Hi Speed	GAS F Fan Hi to N	N/A	Door closed	19 Ohms
Fan Motor LO Speed	GAS S Fan LO to N	N/A	Door closed	25 Ohms
Oven Sensor	CN2-6 to CN2-8		CN2 disconnected from board	1100 Ohms @ room temperature
		P101-6 to P101-8	P101 disconnected from board	
Latch Switch #1	CN2-3 to CN2-5		Door unlocked	0 Ohms
			Door locked - CN2 disconnected from board	Open
	P101-3 to P101-5	Door unlocked	0 Ohms	
		Door locked - P101 disconnected from board	Open	
Latch Switch #2	CN2-4 to CN2-5		Door unlocked - CN2 disconnected from board	Open
			Door locked	0 Ohms
	P101-4 to P101-5	Door unlocked - P101 disconnected from board	Open	
		Door locked	0 Ohms	
Door Switch**	OL to N	P103-2 to P103-1	Door open	0 Ohms
			Door closed	130 Ohms
	N to blue wire terminal on switch	P103-1 to blue wire terminal on switch	Door open	Open
			Door closed	0 Ohms

* Resistance will vary widely with temperature of the glow Bar. If circuit tests open, repair wiring or replace glow-bar.

** Alternate method - Remove door switch (See **Door Switch**.) leave wire harness connected to switch. Check white to red wire: Switch plunger out = 0 Ohms, switch plunger in = approximately 130 ohms. Check white to blue wire: Switch plunger out = open, switch plunger in = 0 ohms.

Component	Test Locations		Conditions	Resistance
	Convection	Non-Convection		
Meat Probe	CN2-1 to CN2-2	N/A	Probe plugged In - CN2 disconnected from board	56 K Ohms @ room temperature
	CN2-1 to GND	N/A	CN2 disconnected from board	Open
	CN2-2 to GND	N/A	CN2 disconnected from board	0 Ohms
Surface Ignitor Switch	Violet wire (disconnected from module) to L1 on board	Violet wire (disconnected from module) to L1 on board	Knob in LITE position	0 Ohms
			Knob NOT in LITE position	Open
Oven Safety Valve	Bake terminals	Bake terminals	Wires disconnected from valve	1 Ohm
	Broil terminals	Broil terminals	Wires disconnected from valve	1 Ohm

Component Voltage Testing

WARNING: Disconnect electrical power before servicing.

Caution: Label all wires prior to disconnection. Wiring errors can cause improper and dangerous operation. Verify operation after servicing.

Component	Test Locations		Conditions	Voltage
	Convection	Non-Convection		
Oven Light	OL to N	P103-2 to P103-1	Door closed and oven light not selected on from control panel	120 VAC
			Door Open	0 VAC
			Door closed and oven light selected on from control panel (relay clicks)	
Bake Glow Bar	Bake to N	P102-2 to P103-1	Bake operation initiated (relay clicks)	120 VAC
			Bake operation not initiated or burner in cycle off status	0 VAC
Broil Glow Bar	Broil to N	P102-1 to P103-1	Broil operation initiated (relay clicks)	120 VAC
			Broil operation not initiated or burner in cycle off status	0 VAC
Warming Drawer Element	WD OUT to N	P102-4 to P103-1	Warming drawer operation initiated (relay clicks)	120 VAC
			Warming drawer operation not initiated or element in cycle off status	0 VAC
Latch Motor	MDL to N	MDL to P103-1	Door closed and clean operation initiated (relay clicks)	120 VAC for 10 seconds locks door
			Door closed and clean operation cancelled (relay clicks)	120 VAC for 10 seconds unlocks door
			Door open and clean operation initiated (relay clicks)	120 VAC until alarm stops operation (25 seconds) - then 0 VAC
Fan Motor Hi Speed	GAS F Fan Hi to N	N/A	Door closed and convection bake or broil initiated	120 VAC (0 VAC during pre-heat)
Fan Motor LO Speed	GAS S Fan LO to N	N/A	Door closed and convection bake or broil initiated	120 VAC (0 VAC during pre-heat)
Surface Ignitor Switches	Violet wire (disconnected from module) to N	Violet wire (disconnected from module) to P103-1	Rotate knob to LITE position	120 VAC

Oven Sensor and Door Switch Test

Note: See *Lock Motor and Door Latch Switch Circuit Information* for door switch function explanation.

1. Remove power from oven.
2. Locate and disconnect the wire harness from CN2 (convection model) or P101 (non-convection model) location on the ERC.
3. Make resistance measurement from the side of the wire harness connector with exposed terminals.
4. If abnormal reading is observed, check leads in the wire harness connector. If any variation, repair or replace wire harness.

Circuit	Terminals	Ohms
Oven Sensor	6 to 8	1100 Ohms (approximately) @ Room Temperature
		2545 Ohms (approximately) @ 815°F (435°C)
Door Unlatched	3 to 5	0 Ohms
	2 to 5	Open
Door Latched	3 to 5	Open
	4 to 5	0 Ohms

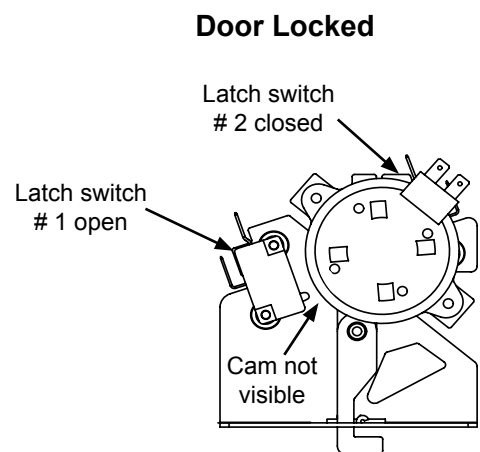
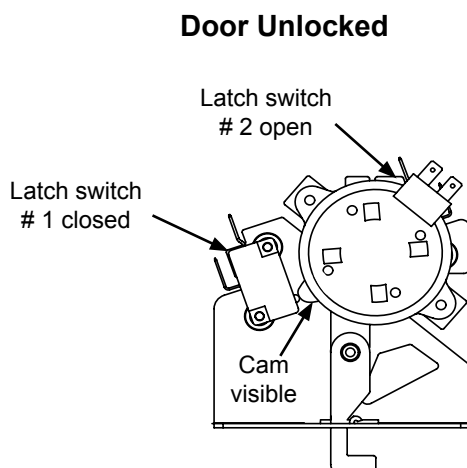
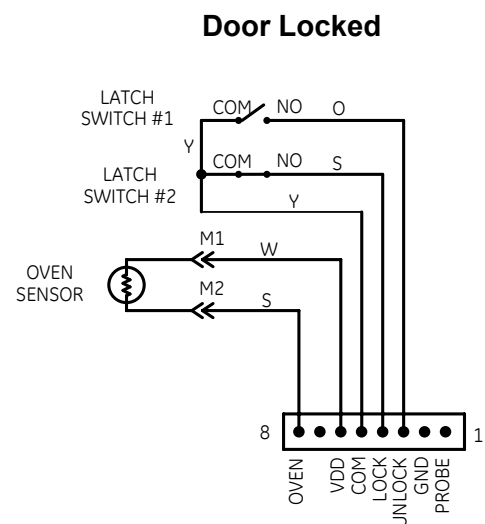
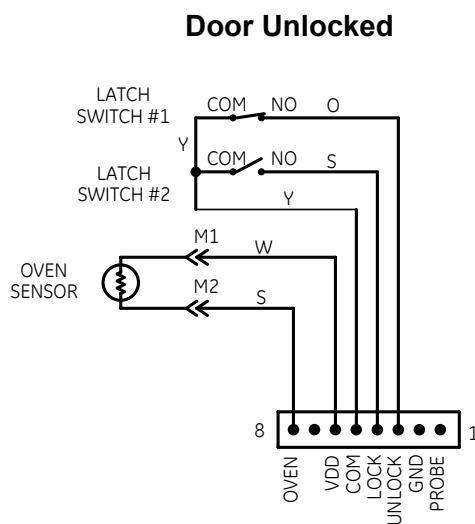

Warming Drawer Performance

The operation of the warming element is controlled by user settings and the ERC. One of 3 warming drawer heat settings can be selected.

After a pre-determined timed preheat period, cycling of the element is controlled by the ERC with a 4-minute duty cycle.

Setting	Preheat Time On	Duty Cycle On Time	Duty Cycle Off Time	Target Temperature
# 1 (Lo)	900 seconds	144 seconds	96 seconds	200°F (93°C)
# 2 (Med)	1200 seconds	192 seconds	48 seconds	250°F (121°C)
# 3 (Hi)	60 seconds	Constant On	0 seconds	284°F (140°C)

Oven Self Clean Operation

On **convection models**: The broil burner heats the oven to approximately 775°F (413°C). After 775°F (413°C) is reached, only the bake burner maintains clean temperature of approximately 815°F (435°C) center temperature. The convection fan does not operate in the clean cycle.

On **non-convection models**: Only the bake burner heats the oven to approximately 815°F (435°C) center temperature.

Cool down occurs during the last 30 minutes of the clean cycle.

The door unlocks at approximately 450°F (232°C) sensor temperature.

Convection Fan Operation

The convection fan is operated by a 2-speed non-reversing motor. The fan motor operates on low speed during convection bake, and on high speed during convection roast. The convection fan does not operate during preheat or self clean.

Schematics and Wiring Diagrams

Gas Range Schematic with Convection Fan

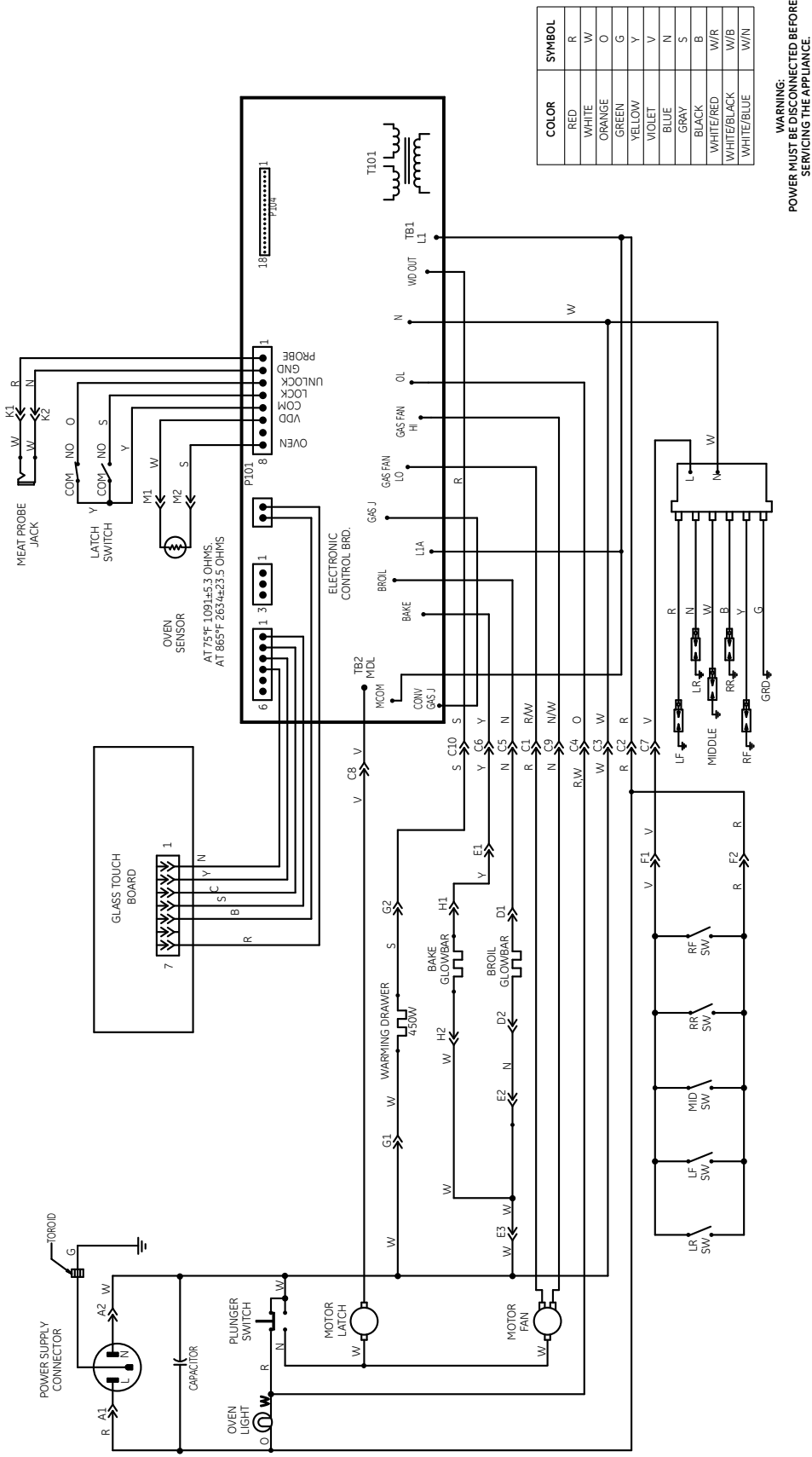

WARNING: Disconnect electrical power before servicing.

Caution: Label all wires prior to disconnection. Wiring errors can cause improper and dangerous operation. Verify operation after servicing.

Gas Range Wiring Diagram with Convection Fan

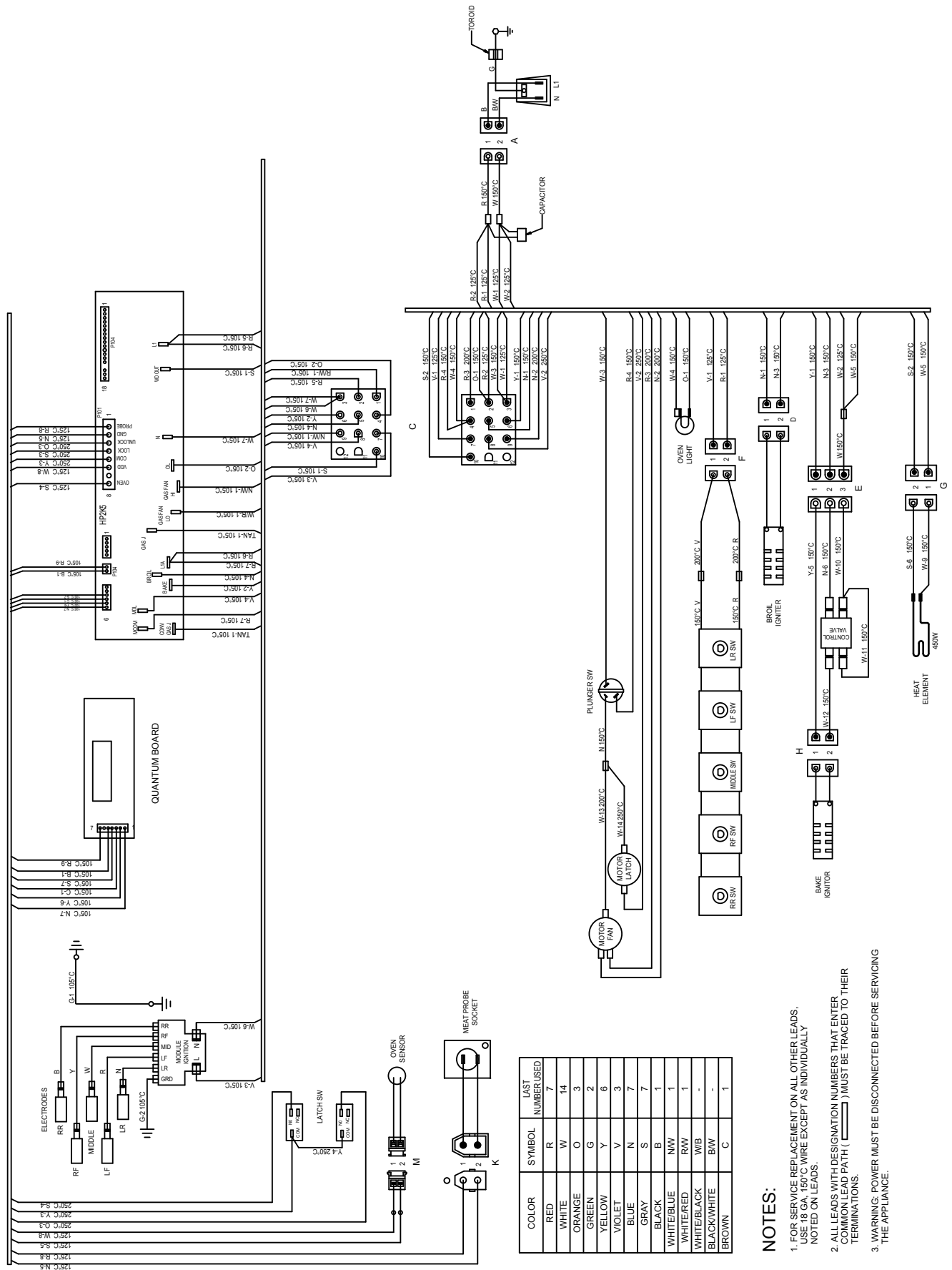

Gas Range Wiring Diagram without Convection Fan

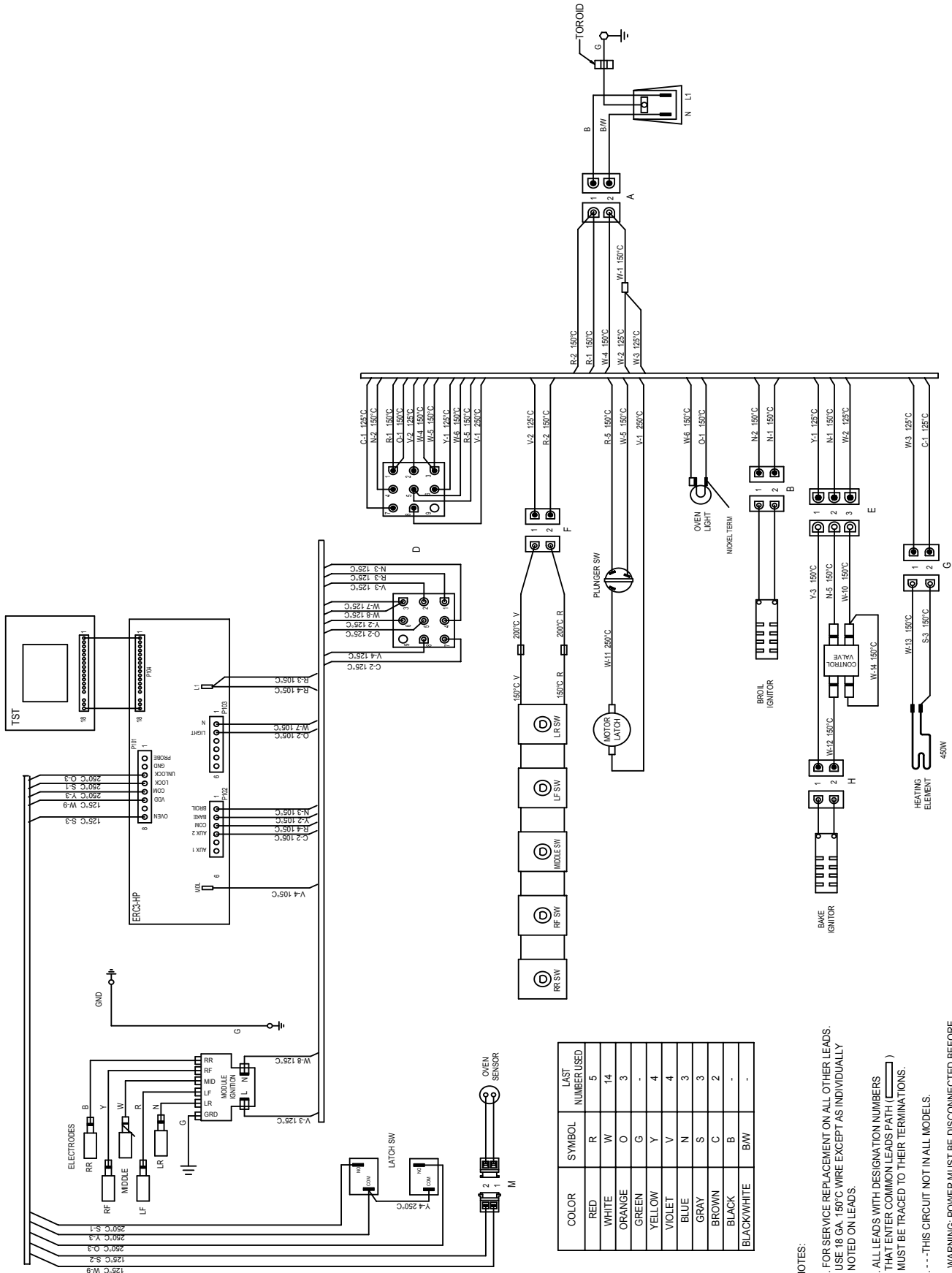

COLOR	SYMBOL	LAST NUMBERED
RED	R	5
WHITE	W	14
ORANGE	O	3
GREEN	G	-
YELLOW	Y	4
VIOLET	V	4
BLUE	N	3
GRAY	S	3
BROWN	C	2
BLACK	B	-
BLACK/WHITE	BW	-

- NOTES:
- FOR SERVICE REPLACEMENT ON ALL OTHER LEADS, USE 18 GA. 150°C WIRE EXCEPT AS INDIVIDUALLY NOTED ON LEADS.
 - ALL LEADS WITH DESIGNATION NUMBERS THAT ENTER COMMON LEADS PATH () MUST BE TRACED TO THEIR TERMINATIONS.
 - THIS CIRCUIT NOT IN ALL MODELS.
 - WARNING: POWER MUST BE DISCONNECTED BEFORE SERVICING THE APPLIANCE.

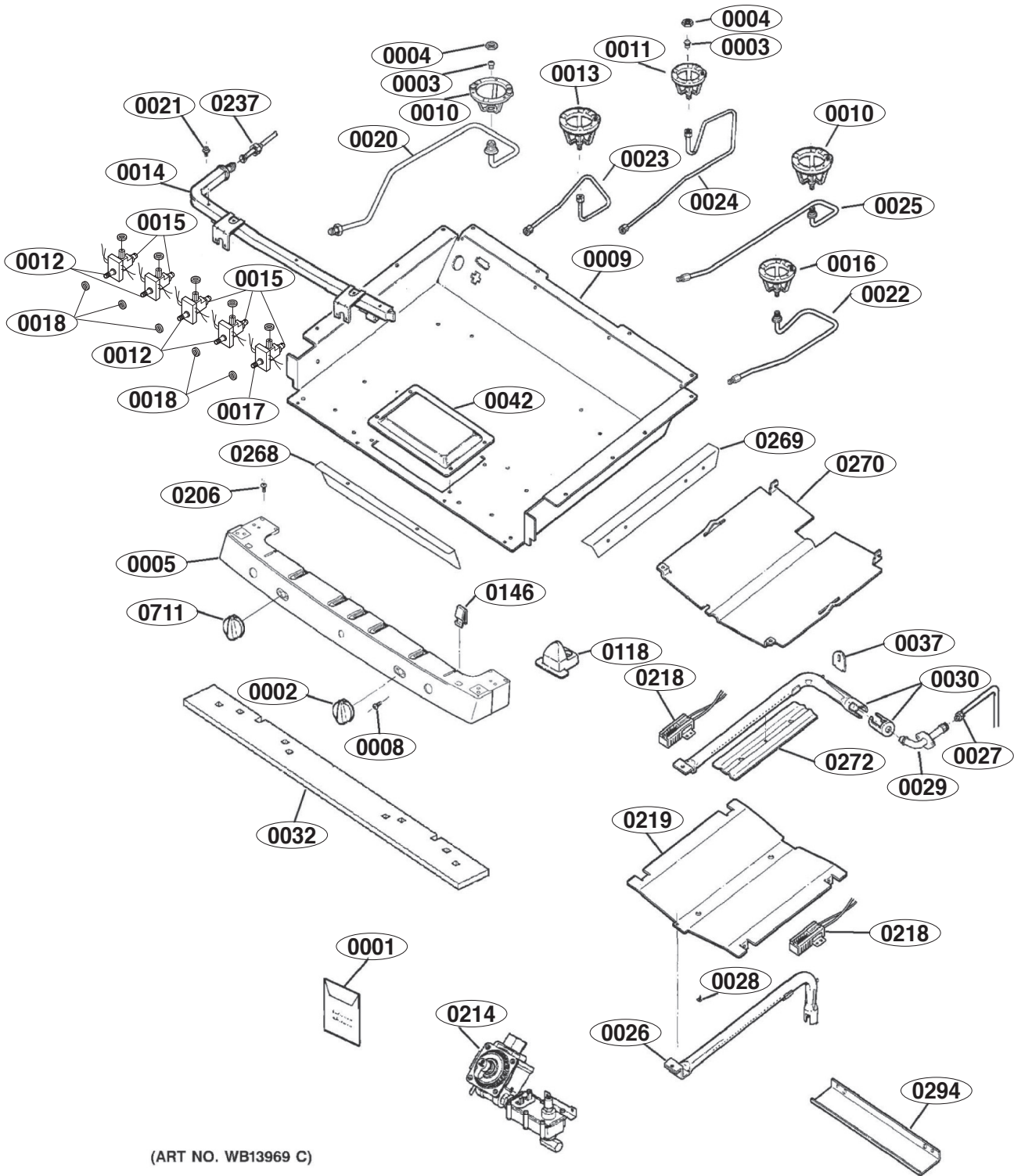

(ART NO. WB13969 C)

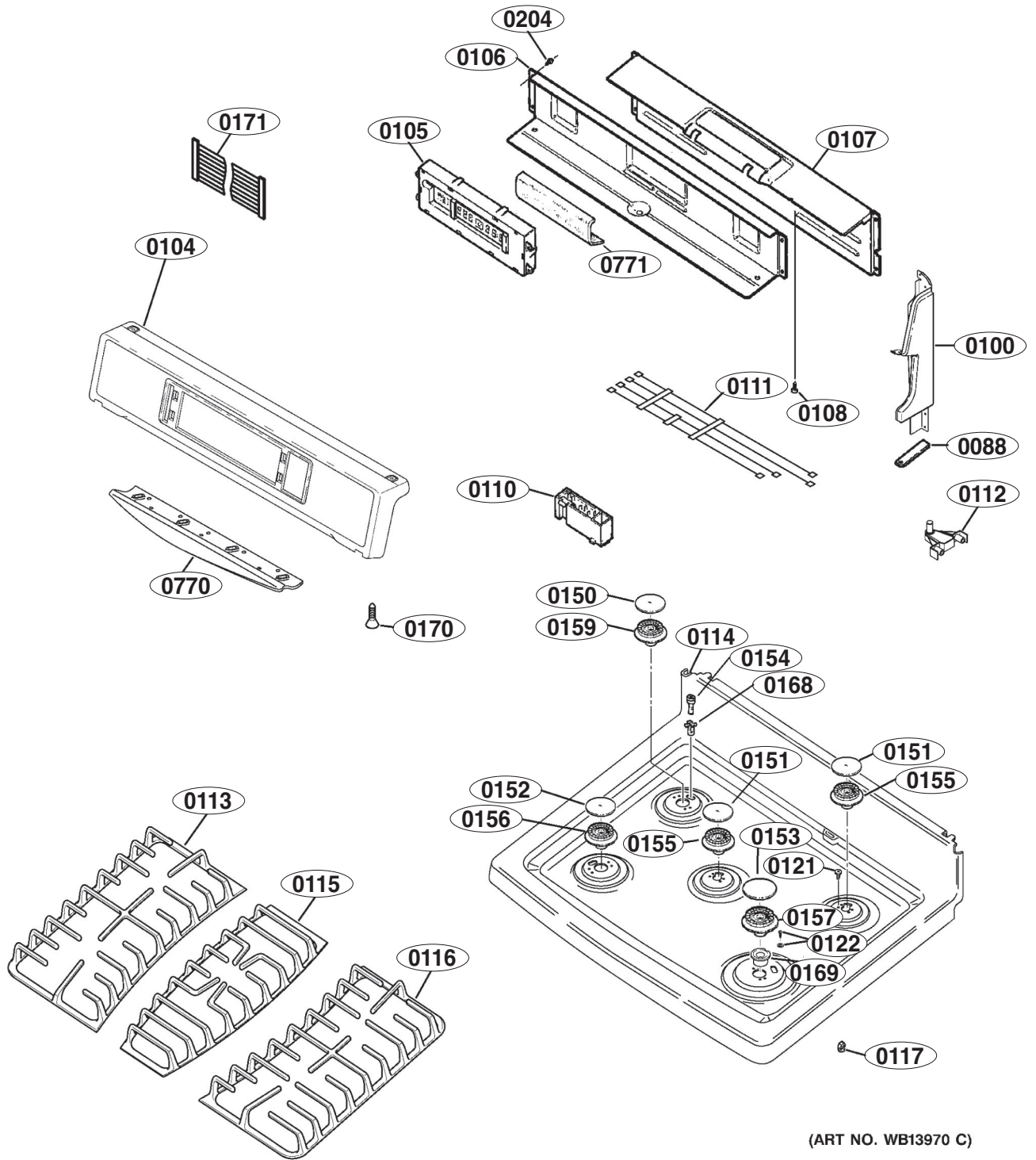

(ART NO. WB13970 C)

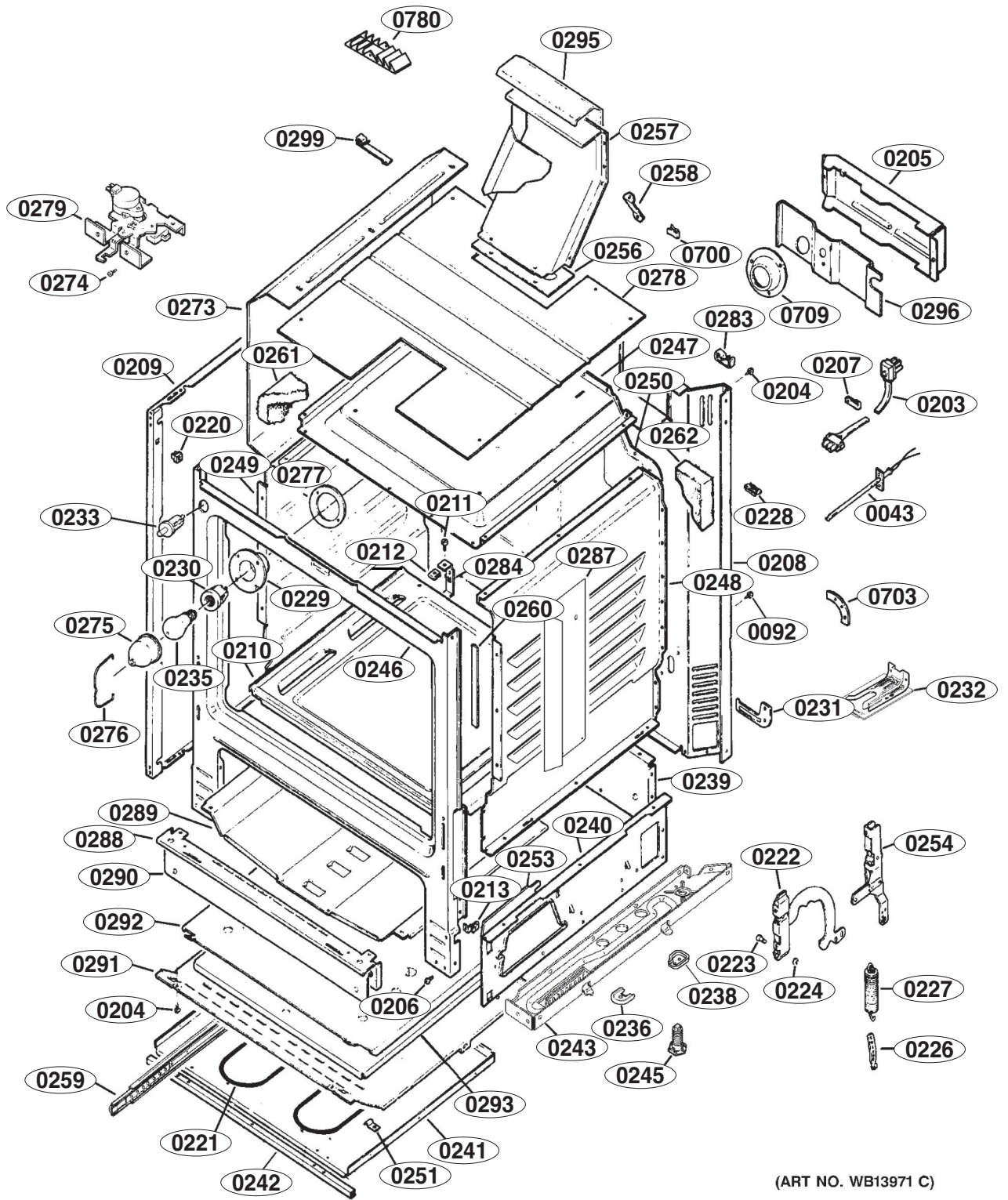

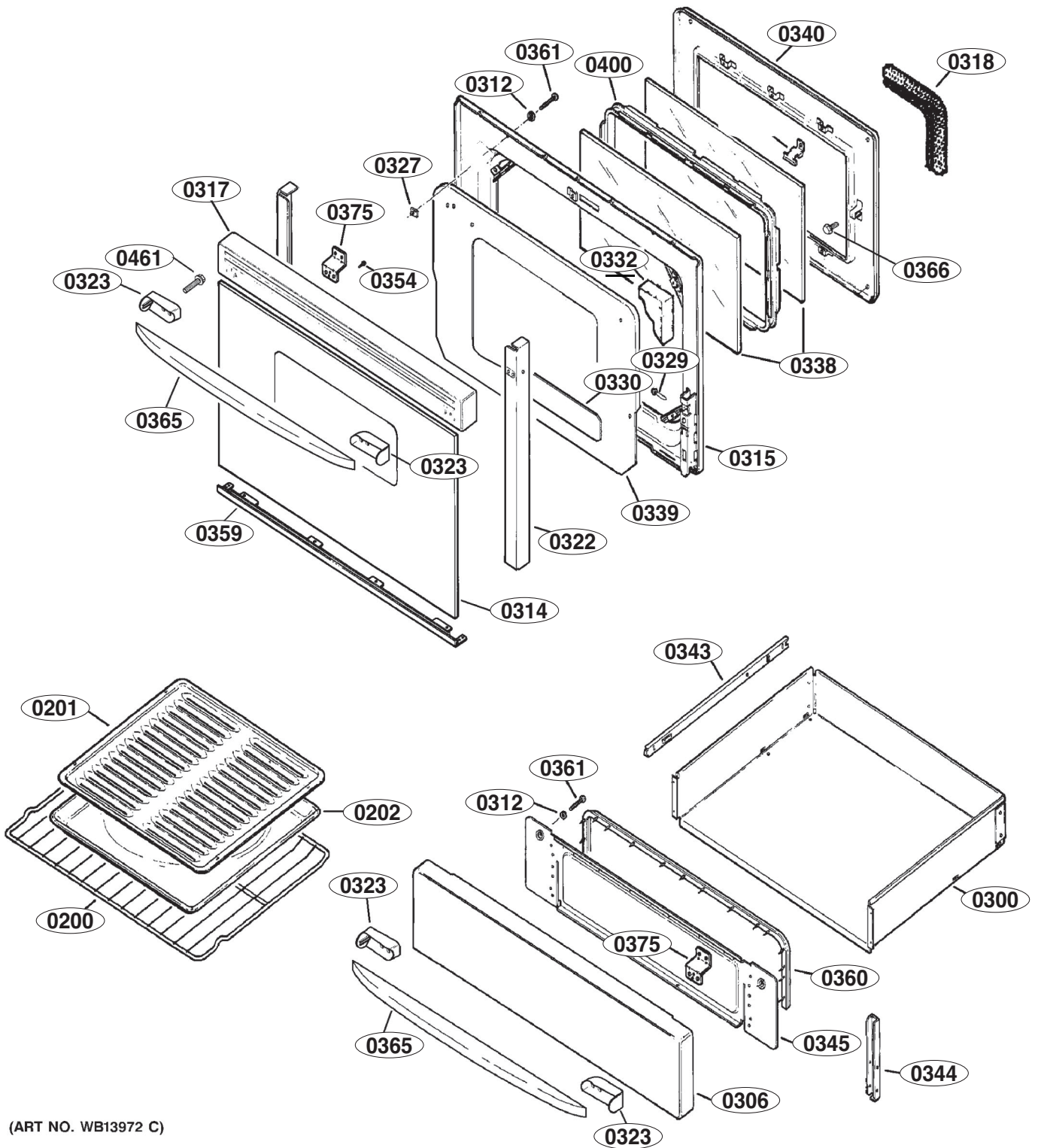

(ART NO. WB13972 C)