

BUILT-IN TRIM KIT INSTALLATION INSTRUCTION

FOR KENMORE TRIM-KIT MODEL - 30" : 63002, 63004, 63009, 64003
 27" : 63012, 63014, 63019, 63013

- FOR USE WITH KENMORE MICROWAVE OVEN MODEL:
 721.62462200, 721.62463200, 721.62464200, 721.62469200, 721.66462500, 721.66463500, 721.66464500, 721.66469500
- UL LISTED - FOR USE OVER KENMORE 30", 27" ELECTRIC BUILT-IN OVENS
 (INCLUDING MODELS - 30" : 41785, 41789, 41085, 41086, 41089, 49002, 49003, 49004, 49009
 27" : 47489, 47485, 47486, 47189)

PARTS LIST

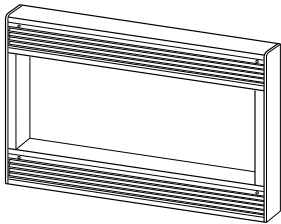

• Trim Kit



• 1" Screws
 (4 Req'd 2 Extra)



• 1/2" Screws
 (11 Req'd 2 Extra)

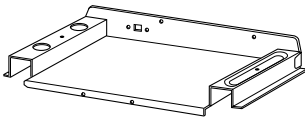

• Bottom Duct (1)

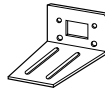

• Bottom Bracket (1)

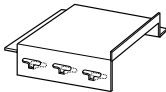

• Upper Duct (1)

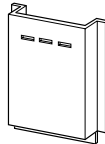

• Side Duct (1)



• Anti-Tip
 Bracket (1)

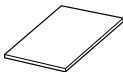

• Installation
 instruction (1)

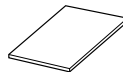

• Template (1)

CUTOUT DIMENSIONS

| | 27" | 30" |
|--------------|---|--------------------------------|
| Height | 16 3/4" | |
| Width | 25 1/2" | 25 1/2" (min.), 28 1/2" (max.) |
| Depth (min.) | 21" with flush mount receptacle. (22 3/4" if non-flush receptacle is used) | |

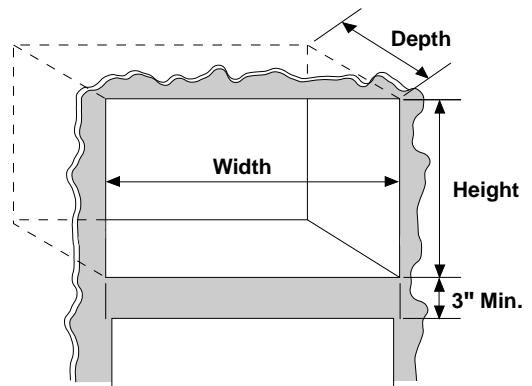

STEP 1

1. Disconnect the microwave oven from the outlet before proceeding with installation.
2. Remove any loose items (turntable, support, etc) from the microwave oven.
3. Fasten the bottom bracket to the bottom duct by using two 1/2" screws.
4. Install bottom duct with four 1/2" screws as shown.

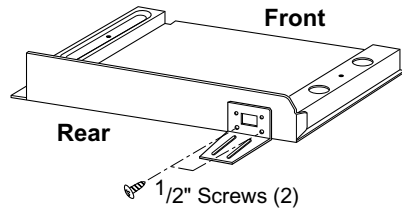

FRONT VIEW OF MICROWAVE

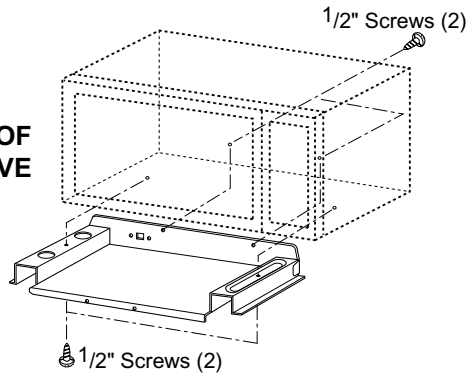

STEP 2

1. Remove the one existing screw from the left side of the microwave oven.
2. Connect the side duct to upper duct as shown.
 - a) Insert projecting tabs of upper duct into holes of side duct.
 - b) Bend tabs up as shown.**NOTE:** Remove any oil or dirt on surface of microwave oven before ducts are attached.

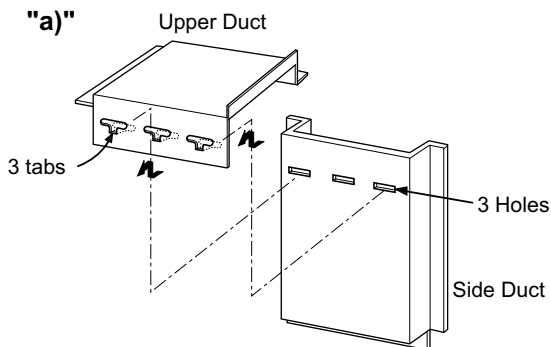

3. Peel off the backing of double sided tape. Attach the side duct and upper duct assembly on the microwave cabinet. Press down firmly on ducts. Fasten duct assembly to left side of cabinet with one existing screw.

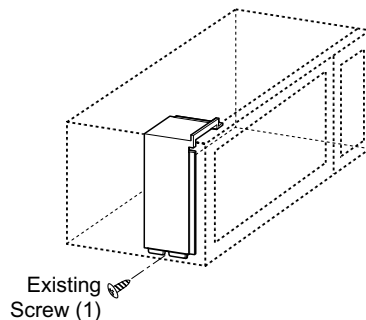

STEP 3

1. On the cutout floor, mark hole centers for the anti-tip brackets as shown using the supplied template. Be sure to align the center line of template to center line of cutout floor.
2. Drill two holes for anti-tip bracket.
(use $\frac{7}{64}$ " drill or #35 drill)
3. Install anti-tip bracket onto cutout floor using two $\frac{1}{2}$ " screws.

DIMENSIONS:

$$A = 4 \frac{1}{4}"$$

$$B = 3"$$

$$C = 18 \frac{3}{16}"$$

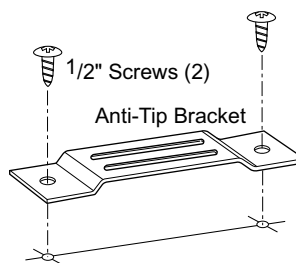
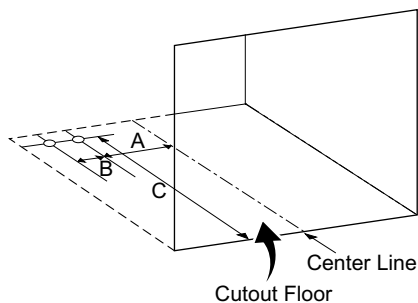

STEP 4

1. Slide microwave oven part way into cabinet opening.
(Bottom brackets must be flat to the cutout floor to engage correctly with anti-tip brackets as shown)
2. Plug in the microwave oven.
3. **Center** the microwave oven within the cut-out opening and slide the microwave oven in the anti-tip bracket.
(Ensure the microwave oven is **accurately centered**)
4. Drill pilot holes (use $\frac{7}{64}$ " drill or #35 drill) through the positioning flange and then install three $\frac{1}{2}$ " screws at the front of the bottom duct as shown.

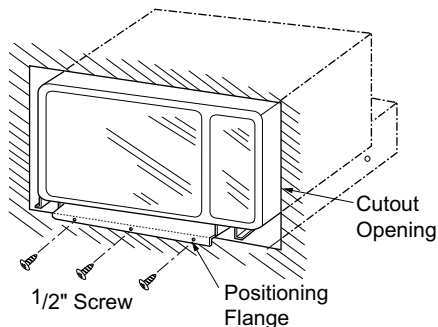
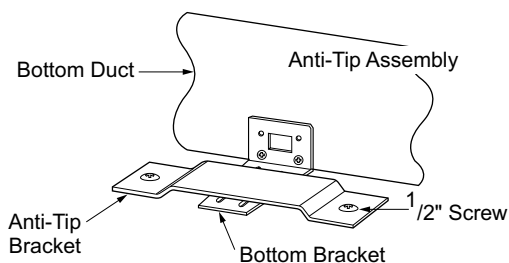

STEP 5

1. Place the trim kit frame over the microwave oven.

Important Note: Trim kit frame orientation is important. Orient the frame so that louvers are sloping downward to the front. (See Figure Detail A).

2. Make sure the trim kit is level and centered with respect to microwave oven. Mark four hole centers through the four mounting holes of the trim kit.

NOTE: Center the trim kit frame equally on all four sides.

3. Remove the trim kit and drill four pilot holes. (use $\frac{7}{64}$ " drill or #35 drill)

4. Attach the trim kit frame by using four 1" screws. Make sure that the orientation is correct as stated above.

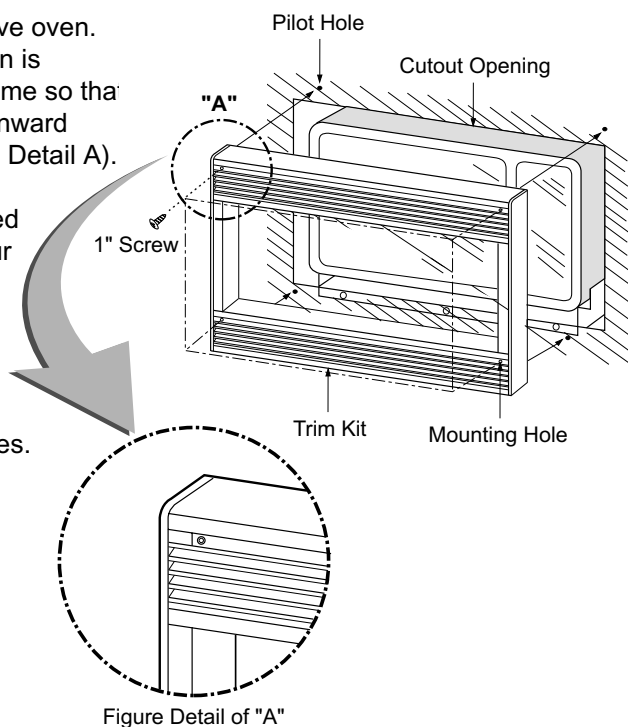

STEP 6

1. Your trim kit is now fully installed. Replace any loose items that have been removed from inside microwave oven.
2. Please keep this installation instruction for future reference.

INSTRUCCIÓN DE INSTALACIÓN DE KIT DE REVESTIMIENTO EMBUTIDO

PARA KIT DE REVESTIMIENTO KENMORE MODELO - 30" :63002, 63004, 63009, 64003
27" :63012, 63014, 63019, 63013

- PARA UTILIZAR CON HORNO MICROONDAS KENMORE MODELO:
721.62462200, 721.62463200, 721.62464200, 721.62469200, 721.66462500, 721.66463500, 721.66464500, 721.66469500
- LISTADO - PARA UTILIZAR SOBRE HORNOS EMBUTIDOS ELÉCTRICOS DE KENMORE 30", 27"
(INCLUYENDO MODELOS - 30" : 41785, 41789, 41085, 41086, 41089, 49002, 49003, 49004, 49009
27" : 47489, 47485, 47486, 47189)

LISTA DE PARTES

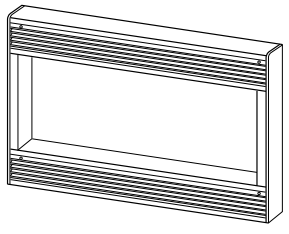

• Kit de Revestimiento



• Tornillos de 1"
(4 Req'd 2 Extra)



• Tornillos de 1/2"
(11 Req'd 2 Extra)

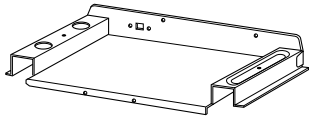

• Conducto inferior (1)

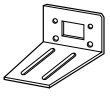

• Soporte inferior (1)

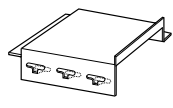

• Conducto superior (1)

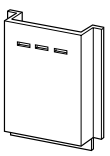

• Conducto lateral (1)



• Soporte Anti-tip (1)

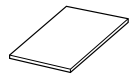

• Instrucción de Instalación (1)

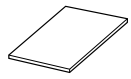

• Plantilla (1)

DIMENSIONES EXTERNAS

| | 27" | 30" |
|--------------------|---|--------------------------------|
| Altura | 16 3/4" | |
| Ancho | 25 1/2" | 25 1/2" (min.), 28 1/2" (max.) |
| Profundidad (min.) | 21" con Recipiente eleva-flujo. (22 3/4" si se una recipiente de no-flujo) | |

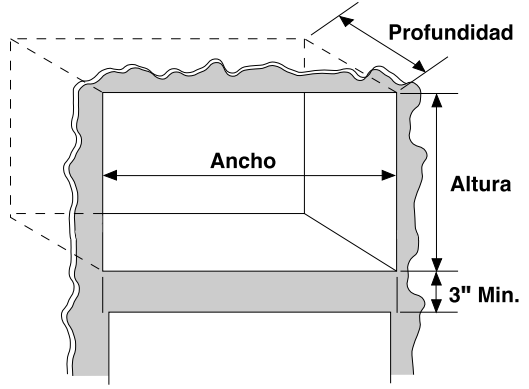

PASO 1

1. Desconecte el horno microondas de la toma antes de proceder con la instalación.
2. Quite cualquier elemento suelto (mesa giratoria, soporte, etc) del horno microondas.
3. Asegure el soporte inferior al conducto inferior utilizando 2 tornillos de 1/2" .
4. Instale el conducto inferior con cuatro tornillos de 1/2" como está ilustrado.

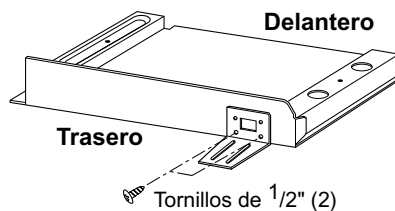

VISTA FRONTAL DEL MICROONDAS

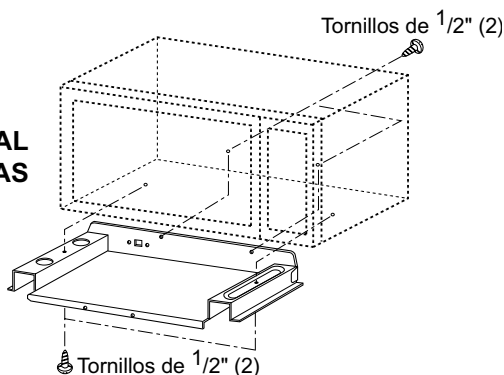

PASO 2

1. Quite el tornillo existente del lado izquierdo del horno microondas.
2. Conecte el conducto lateral al superior como está ilustrado.
 - a) Inserte lengüetas proyectadas del conducto superior dentro de los hoyos del conducto lateral.
 - b) Doblar las lengüetas hacia arriba como está ilustrado

NOTA: Quite cualquier aceite o suciedad de la superficie del horno microondas antes de fijar los conductos.

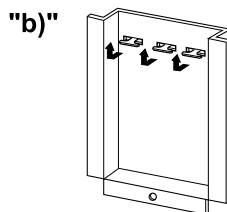
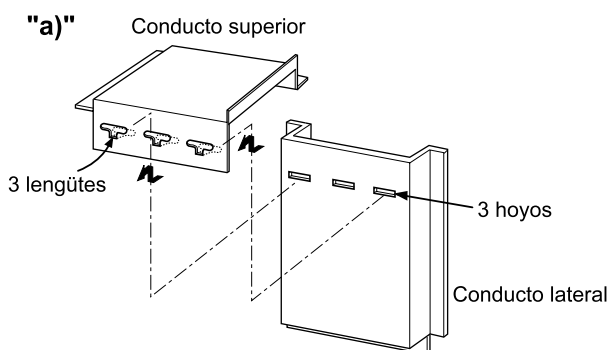

3. Desprenda el refuerzo de la cinta de dos lados. Ajuste el conjunto del conducto lateral y el superior sobre la cabina del microondas. Presione firmemente hacia abajo sobre los conductos. Asegure el conjunto de conducto al lado izquierdo de la cabina con un tornillo existente.

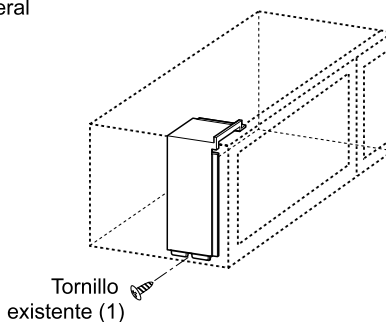

PASO 3

1. Sobre el suelo externo, marque hoyos centrados para los soportes anti-tip como está ilustrado utilizando la plantilla suministrada. Asegúrese de alinear la línea central de la plantilla para centrar la línea del suelo externo.
2. Taladre dos hoyos para el soporte anti-tip.
(Use taladro de $\frac{7}{64}$ " o el taladro #35)
3. Instale el soporte anti-tip sobre el suelo externo utilizando dos tornillos de $\frac{1}{2}$ ".

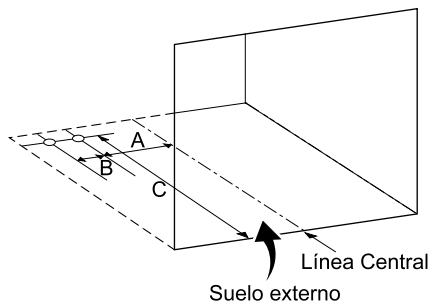

DIMENSIONES :

$$A = 4 \frac{1}{4}''$$

$$B = 3''$$

$$C = 18 \frac{3}{16}''$$

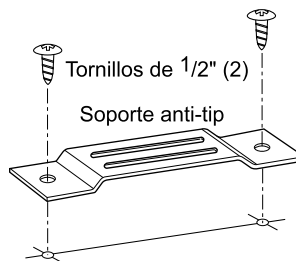

PASO 4

1. Deslice la parte del horno microondas hacia adentro de la apertura de la cabina.
(Los soportes inferiores deben estar pegados al piso externo para que se encaje correctamente con los soportes anti-tip como está ilustrado)
2. Enchufe el horno microondas
3. **Centre** el horno microondas entre las aperturas externas y deslice el horno microondas en el soporte anti-tip.
(Asegúrese de que el horno microondas está **exactamente centrado**)
4. Taladre hoyos pilotos (use taladro de $\frac{7}{64}$ " o el taladro #35) a través del reborde de posicionamiento y luego instale tres tornillos de $\frac{1}{2}$ " en la parte delantera del conducto inferior como está ilustrado.

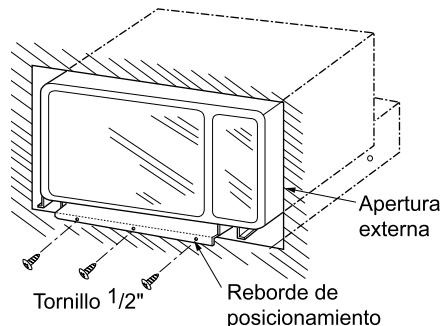
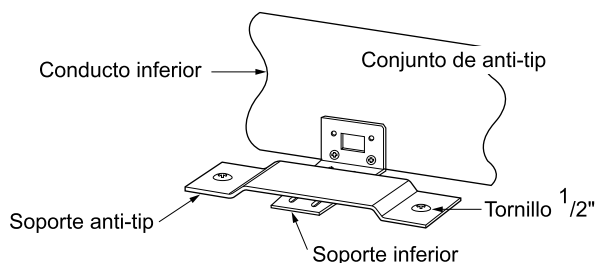

PASO 5

1. Coloque la estructura del kit de revestimiento sobre el horno microondas.

Nota Importante: La orientación de la estructura del kit de revestimiento es importante. Oriente la estructura de tal forma que las persianas estén dirigidas hacia abajo hasta adelante (Ver el Detalle de la figura A).

2. Asegúrese de que el kit de revestimiento está nivelado y centrado con respecto al horno microondas. Haga cuatro hoyos centrales a través de cuatro hoyos montados del kit de revestimiento.

NOTA: Centre la estructura del kit de revestimiento igualmente en los cuatro lados.

3. Quite el kit de revestimiento y taladre cuatro hoyos pilotos.

(use taladro de $\frac{7}{64}$ " o el taladro #35)

4. Asegure la estructura del kit de revestimiento utilizando cuatro tornillos de 1". Asegúrese de que la orientación está correcta como está dicho arriba.

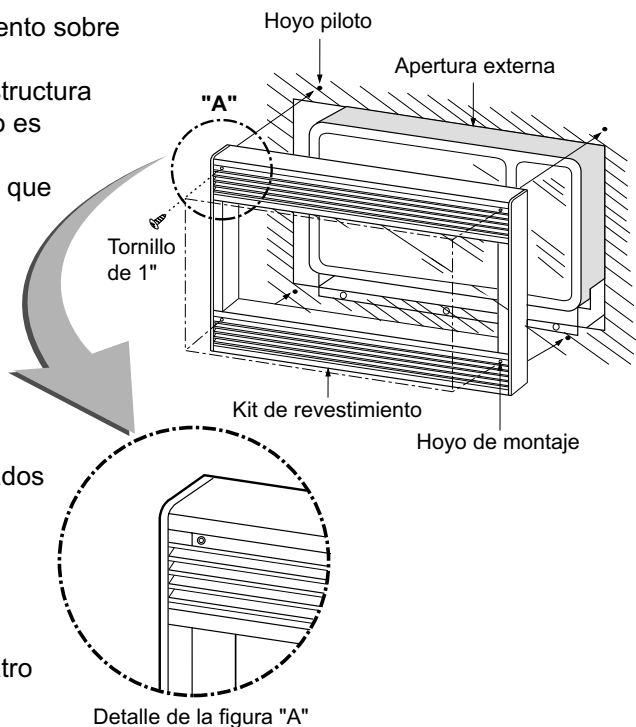

PASO 6

1. Su kit de revestimiento está completamente instalado. Recolecte todos los elementos sueltos que haya sido removido del interior del horno microondas.
2. Por favor, guarde esta instrucción de instalación para ser referenciado en el futuro.