

BUILT-IN TRIM KIT INSTALLATION INSTRUCTION

(KEEP FOR FURTHER REFERENCE)

FOR TRIM-KIT MODELS - 27": AST2780AB, AST2780AW, AST2780AC, AST2780AS

- 30": AST3080AB, AST3080AW, AST3080AC, AST3080AS

• **CAUTION:** For personal safety, remove house fuse or open circuit breaker before beginning installation to avoid severe or fatal shock injury.

• **FOR USE WITH MICROWAVE OVEN MODELS: ACM1580A/JMC9158AA**

• **FOR USE OVER ELECTRIC HEAT SOURCE MODELS:**

- 27": AOES2730, AOCS2740, ACO27SE1, JJW8127, JJW8527, JJW9527

- 30": AOES3030, AOCS3040, JJW8130, JJW8530, JJW9530

1 PARTS INCLUDED

• Trim Kit

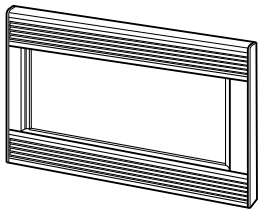

• Upper Duct (1)

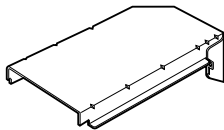

• Bottom Duct (1)

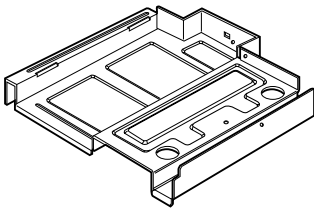

• 1/2" Screws (16 Req'd 2 Extra)



• Anti-Tip Bracket (1)

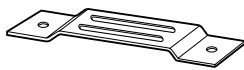

• 1" Screws (4 Req'd 2 Extra)



• Rear Duct (1)

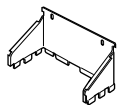

• Bottom Bracket (1)

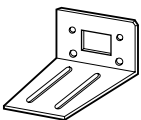

• Template (1)

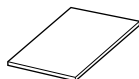

2 CUTOUT DIMENSIONS

	27"	30"
Height	17 1/4"	17 1/4"
Width	25 1/2"	28 1/2"
Depth (min.)	23 3/4"	23 3/4"

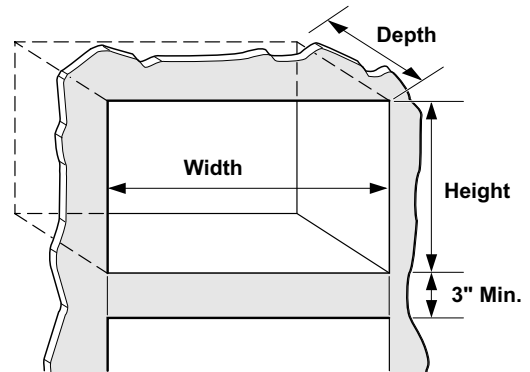

3

1. Disconnect the microwave oven before proceeding with installation.
2. Remove any loose items inside the microwave oven.
3. Fasten the bottom bracket to the bottom duct by using four 1/2" screws.

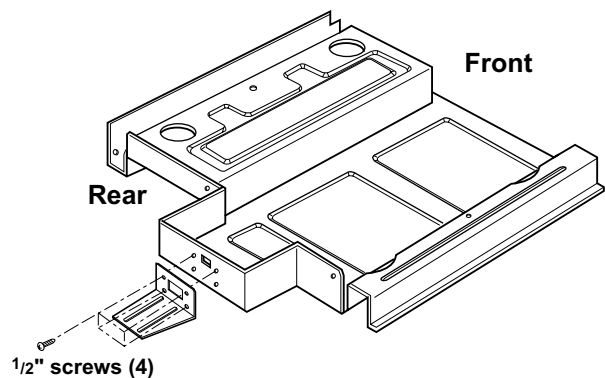

3

4. Install rear duct to the bottom duct with one $\frac{1}{2}$ " screw.
5. Remove the one existing screw from the right side of the microwave oven.
6. Install bottom duct assembly with six screws as shown. Fasten bottom duct to the right side of cabinet with one existing screw.

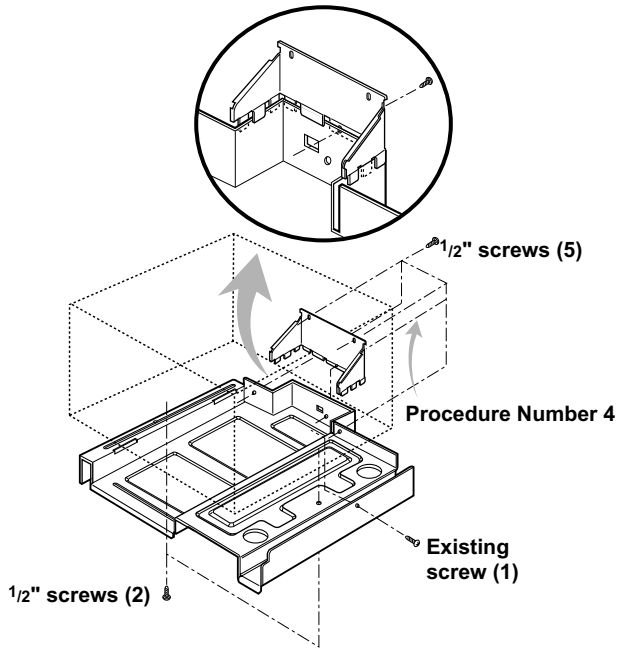

4

1. Remove the two existing screws from the back side of the oven.
2. Peel off the backing of double sided tape. Attach the upper duct on the microwave cabinet. Press down firmly on duct. Fasten duct to back side of cabinet with two existing screws as shown.

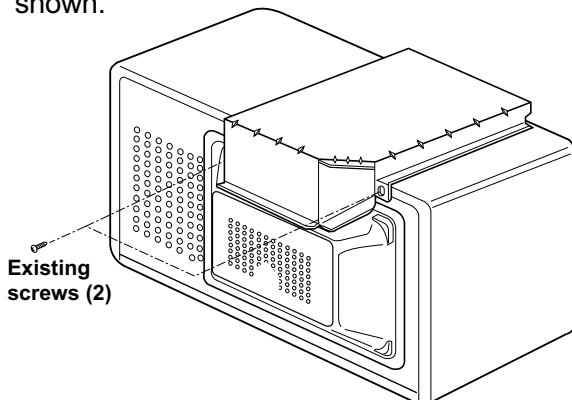

5

1. On the cutout floor, mark hole centers for the anti-tip brackets as shown using the supplied template. Be sure to align the center line of template to center line of cutout floor.
2. Drill two holes for anti-tip bracket. (use $\frac{7}{64}$ " drill or #35 drill)
3. Install anti-tip bracket onto cutout floor using two $\frac{1}{2}$ " screws.

DIMENSIONS:

A = $1\frac{3}{16}$ "
B = 3"
C = $20\frac{1}{16}$ "

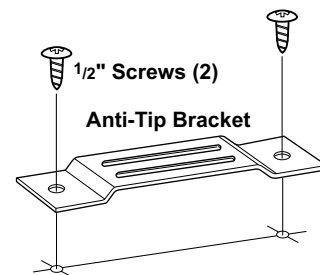
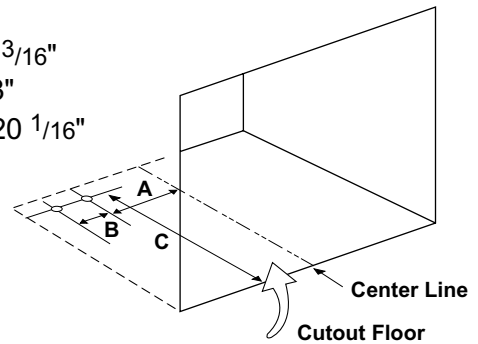

6

- Slide microwave oven part way into cabinet opening. (Bottom brackets must be flat to the cutout floor to engage correctly with anti-tip brackets as shown.)

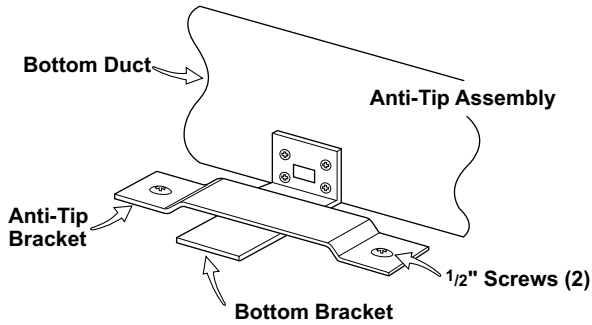

- Plug in the microwave oven.
- Center the microwave oven within the cut-out opening and slide the microwave oven in place, engaging the anti-tip brackets. (Ensure the microwave oven is accurately centered)
- Drill pilot holes (use $\frac{7}{64}$ " drill or #35 drill) through the positioning flange and then install three $\frac{1}{2}$ " screws at the front of the bottom duct as shown.

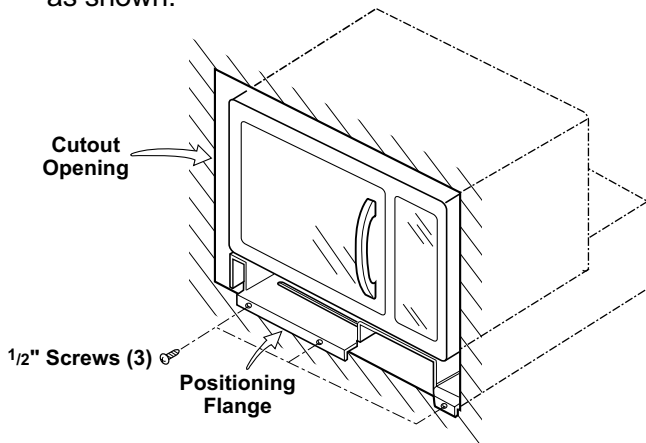
**7**

- Place the trim kit frame over the microwave oven.

Important Note: Trim kit frame orientation is important. Orient the frame so that louvers are sloping downward to the front. (See Figure Detail of "A").
- Make sure the trim kit is level and centered with respect to microwave oven. Mark four hole centers through the four mounting holes of the trim kit.

NOTE: Center the trim kit frame equally on all four sides.
- Remove the trim kit and drill four pilot holes. (use $\frac{7}{64}$ " drill or #35 drill)
- Attach the trim kit frame by using four 1" screws. Make sure that the orientation is correct as stated above.

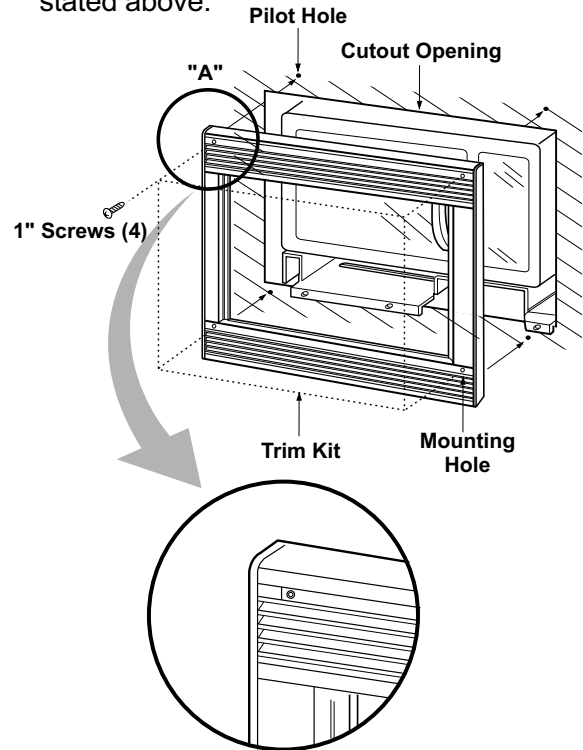

Figure Detail of "A"

8

- Your trim kit is now fully installed. Replace any loose items that have been removed from inside microwave oven.
- Please keep this installation instruction for future reference.