

This Owner's Manual is provided and hosted by [Appliance Factory Parts](#).



# Orion OC-1 Owner's Manual

[Shop genuine replacement parts for Orion OC-1](#)



[Find Your Orion Grill Parts - Select From 1 Models](#)

----- Manual continues below -----

## **⚠ WARNING:**

**FOR OUTDOOR USE ONLY. Carbon Monoxide Hazard. Never use indoors (home, garage, enclosed porch, tent). Keep the cooker away from buildings, garages, flammable materials, flammable fluids and automobiles while in use.**

**Do not leave unit unattended at any time.**

## **⚠ WARNING:**

Failure to follow these instructions could result in death, serious injury, and/or property loss. Read and follow instructions carefully before using the Orion Cooker®! Always read the owners manual before using the Orion Cooker® and follow specific usage, assembly and safety procedures. If you have any questions, contact Orion Cooker®.

- The Orion Cooker® is designed for OUTDOOR HOUSEHOLD USE Only. Never use the Orion Cooker® inside a house, trailer, tent, garage, or any enclosed area because carbon monoxide may accumulate and cause death. Do not use the Orion Cooker® as a space heater.
- Set up the Orion Cooker® away from buildings, dry leaves, or any combustible materials. Avoid high traffic areas and always cook in a well-ventilated area. Be mindful of windblown sparks.
- Do not ever use the Orion Cooker® unless all parts of the unit are firmly in place and the unit is stable.
- Do not wear loose clothing with hanging shirt tails, frills, or apron strings around the cooker when lighting or cooking.
- Never allow children to operate the Orion Cooker® or play near it. Keep animals and bystanders out of the cooker area.
- Do not allow anyone to conduct activities around the Orion Cooker® when it is in use, or immediately following its use. Never operate the Orion Cooker® near combustible surfaces.
- Once the Orion Cooker® has been lit, do not touch the charcoals to see if they are hot.

- Allow coals to burn out completely and let the ashes cool for 48 hours before disposing of them.
- Dispose of cold ashes by wrapping them in heavy-duty aluminum foil and putting them in a non-combustible container. Be sure there are no other combustible materials in or near the container.
- If you have to dispose of the ashes in less time than it takes for them to completely cool, remove the ashes from both coal rings keeping them in heavy duty foil and soak them completely with water before disposing in a non-combustible container. If you have any questions regarding the assembly or operation of the Orion Cooker®, please contact us at support@orioncooker.com or 1-866-891-3663.

## **CAUTION:**

Never move the unit while in use. If moving becomes necessary, do not touch body or lid as they may be very hot.

## **GENERAL INSTRUCTIONS FOR SAFE USE OF COOKER:**

1. Do not burn trash, leaves, paper, cardboard or plywood in the cooker. The use of seasoned hardwood is recommended. Avoid using softwood such as pine or cedar because they are likely to throw sparks.
2. Keep all screws and nuts tight to be sure cooker is in safe working condition. Inspect on regular basis to ensure that the cooker is operational.

**NOTE: After repeated use, a discoloration of the metal will occur.**

## **⚠ WARNING ⚠**

### **CARBON MONOXIDE HAZARD**

Burning charcoal gives off carbon monoxide, which has no odor and can kill you. DO NOT burn charcoal inside homes, vehicles or tents. Use only in well ventilated areas.

*Dear Valued Customer:*

Thank you for purchasing the Orion Cooker®. You will find the Orion Cooker® takes “cooking out” to an exciting new level. Now it is possible to have the moist, tender product you long for with a fraction of the time and effort. The Orion Cooker® provides enough diversity to conquer any cooking situation. Hang six racks of baby back ribs on the rib hangers, cook a moist turkey on the poultry stand or cook a salmon filet on one of the three cooking grates—Wow, you and your guests are in for a culinary treat!

We invite you to try any and all foods on the Orion Cooker® and submit them to us on the recipe section of our web site: [www.orioncooker.com](http://www.orioncooker.com). Again, our many thanks for purchasing the Orion Cooker®. If you have any questions, feel free to contact us at [support@orioncooker.com](mailto:support@orioncooker.com) or 1-866-891-3663.

*Best Regards,*

*Orion Cooker®*



# Table of Contents

Orion Cooker® Assembly .....	pg. 6
Accessory Assembly Options.....	pg. 9
Items Needed to Cook on the Orion Cooker® .....	pg. 10
General Cooking Instructions .....	pg. 10
General Cooking Instructions Displayed .....	pg. 11
General Cooking Guide.....	pg. 13
Recipes .....	pg. 13
Boston Butt.....	pg. 13
Beef Brisket.....	pg. 14
Wickers Whole Chicken.....	pg. 14
Hush Yo’ Mouth Baby Back Ribs .....	pg. 15
Grandpa Fitz’s Turkey .....	pg. 15
Salmon Filet.....	pg. 16
Standing Rib Roast.....	pg. 17
Northeastern Clam Bake.....	pg. 17
“Mello” Boston Butt .....	pg. 18
Tequila Chicken Wings .....	pg. 18
Alder Chicken Halves .....	pg. 19
White Wine Pork Chops.....	pg. 19
Grey Poupon Pork Tenderloin.....	pg. 20
Wood Chip Recommendations .....	pg. 21
Meat Doneness Table .....	pg. 21
Frequently Asked Questions:.....	pg. 22

## Orion Cooker® Assembly:

Please read all instructions and warnings before assembly.

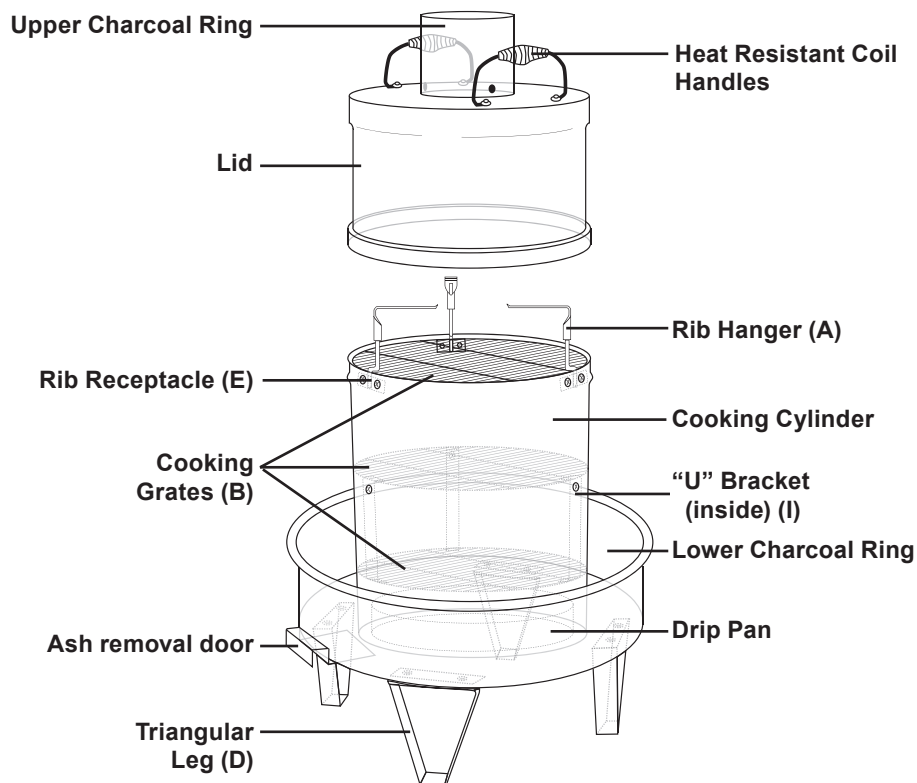

### Parts Included:

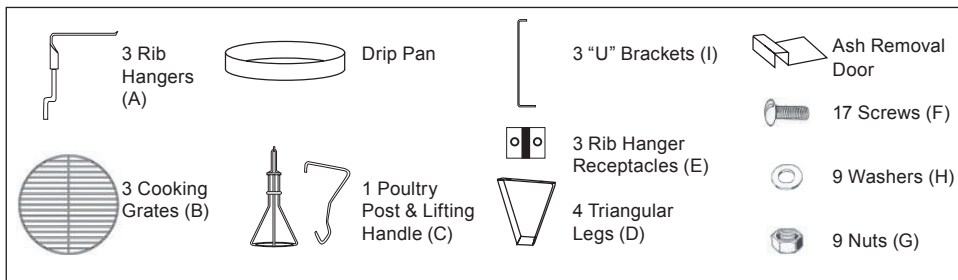

**Tools needed:** Phillips head screwdriver, Crescent wrench or socket wrench set.

## STEP 1: ATTACH LEGS

1. Align the two holes of the legs (D) with the two holes on the metal strips located underneath the lower charcoal ring.
  2. Place screw (F) in aligned holes and tighten using a Phillips head screwdriver.
- Repeat steps 1 and 2 for remaining legs.

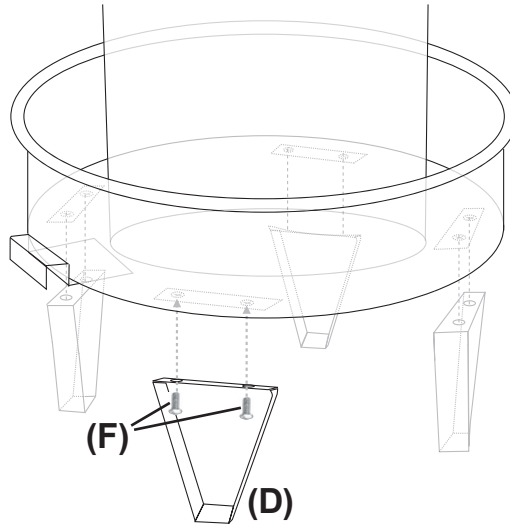

## STEP 2: ATTACH "U" BRACKETS

1. Align the hole at the top of the "U" bracket (I) with the hole in the center of the cooking cylinder and slide one screw (F) through the aligned holes.
  2. Place washer (H) and nut (G) over screw on the inside of the cooking cylinder. Tighten nut (G) using Crescent wrench and Phillips head screwdriver.
- Repeat steps 1 and 2 for the remaining "U" brackets.

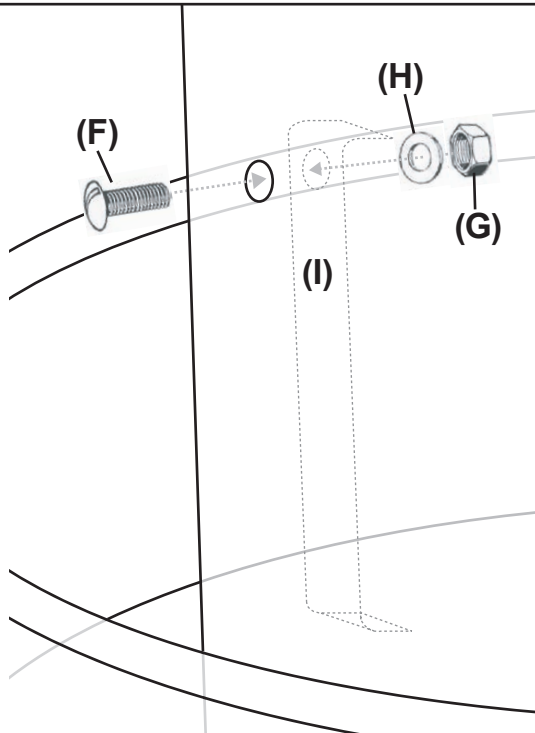

7

**WARNING: USING THE COOKER INDOORS CAN CAUSE CARBON MONOXIDE POISONING!  
DO NOT LIGHT COOKER NEAR ANY FLAMMABLE OBJECT!**

# STEP 3: ATTACH RIB RECEPTACLES

1. Align the two holes of the Rib Receptacle (A) with the top two holes in the cooking cylinder and slide two screws (F) through the aligned holes.
  2. Place washer (H) and nut (G) over screw on the inside of the cooking cylinder. Tighten nut (G) using Crescent wrench and Phillips head screwdriver.
- Repeat steps 1 and 2 for remaining Rib Receptacles.
  - *(Top view close-up below)*

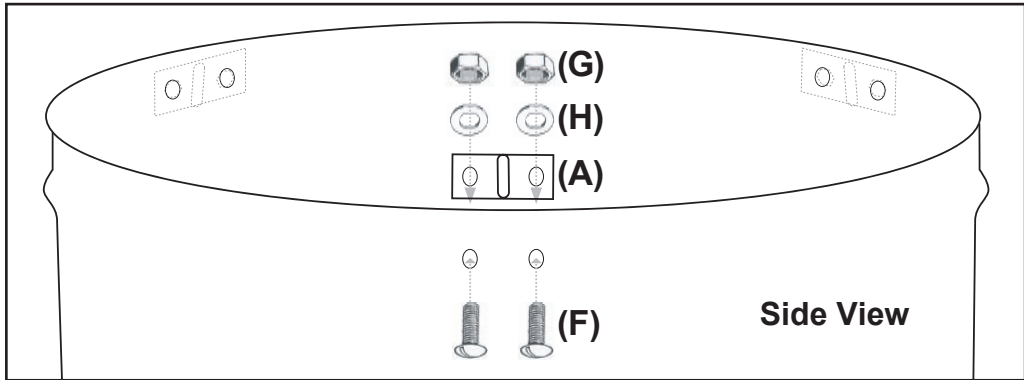
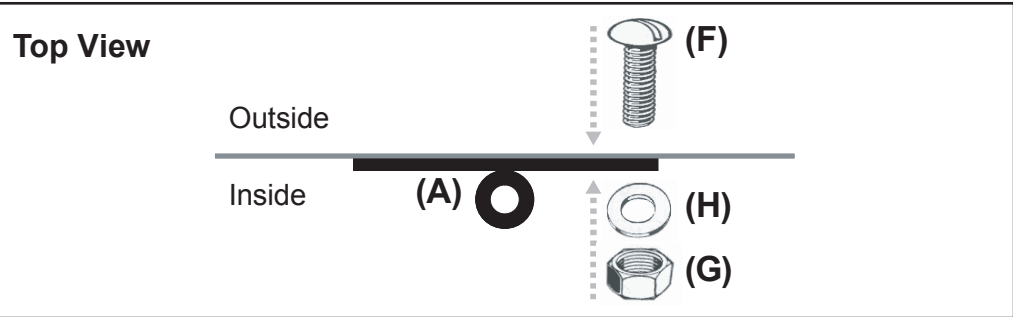
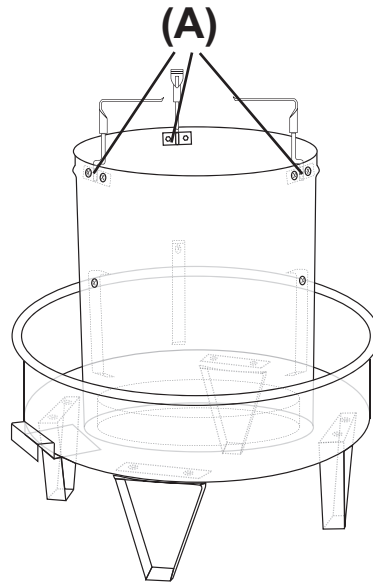

**WARNING: USING THE COOKER INDOORS CAN CAUSE CARBON MONOXIDE POISONING!  
DO NOT LIGHT COOKER NEAR ANY FLAMMABLE OBJECT!**

## Accessory Assembly Options

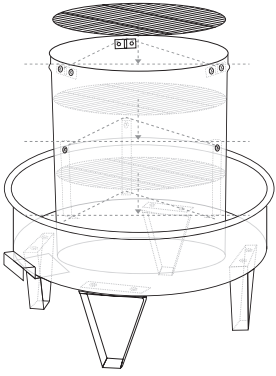

### 3 Cooking Grates:

Roasts, small chickens, pork tenderloins, pork chops, chicken wings, chicken halves/parts, fish filet and seafood—Grates are removable and can be used individually to accommodate larger cuts of meat or can be used together to accommodate large quantities.

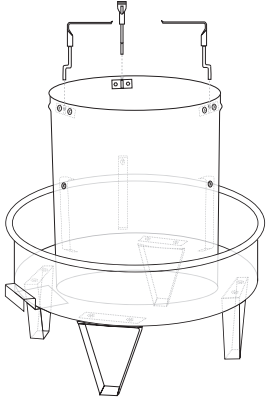

### 3 Rib Hangers:

Ribs—Remove all cooking grates. With a knife, pierce ribs between the 2nd and 3rd bone on the wide end of the rack. Hang ribs vertically by sliding rib hanger through the opening.

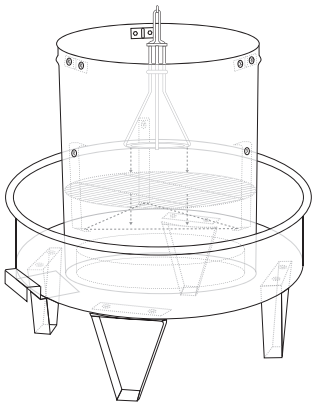

### Poultry Stand and Lifting Handle:

Whole turkeys and large roaster chickens—Ensure neck and giblets are removed from poultry product. Insert poultry stand into large cavity of the poultry product, ensuring the top of the poultry stand is exposed through the neck. Remove the top two cooking grates. Use lifting handle to place stand on the bottom cooking grate. Ensure stand is well balanced on cooking grate. When cooking is complete, use lifting handle to remove poultry stand.

## Items Needed to Cook on the Orion Cooker®

- 13-15 lb. bag of instant light charcoal briquettes. **Note:** For smaller cuts of meat or smaller quantities of food less charcoal can be used. When less charcoal is used, make sure that the briquettes in the lower charcoal ring are touching the cooking cylinder.
- **Optional:** Wood chips. Wood chips add extra color and flavor to the meat product. When using wood chips, there is no need to soak them prior to cooking. A list of options for wood chips will be offered in the coming pages.
- **Note:** The majority of cooking applications do not require liquid in the drip pan. The only exceptions are beef briskets, fish and seafood.

## General Cooking Instructions

1. For easy clean up, line drip pan with tin foil.
2. Place the drip pan in cooking cylinder.
3. Place wood chips between the side of the drip pan and the inside wall of the cooking cylinder. (Optional) Note: Do not place wood chips underneath the drip pan. The heat from the outer charcoal ring will cause the chips to smolder if placed up against the wall of the cooking cylinder.
4. Prepare food and choose appropriate accessory.
5. Affix food to appropriate cooking accessory and place in the cooking cylinder or place food on cooking grates in the cooking cylinder.
6. Secure the lid on the cooking cylinder.
7. Place a 15 lb. bag of instant light charcoal around the lower charcoal ring, with the exception of 10-12 briquettes. Note: For smaller cuts of meat or smaller quantities of food, less charcoal can be used. When less charcoal is used, make sure that the briquettes in the lower charcoal ring are touching the cooking cylinder.
8. Place the remaining 10-12 briquettes in the upper charcoal ring on the lid.
9. Light charcoal in both the upper and lower charcoal rings and return at the designated time!

**Trust our general cook times. Do not check before designated time.**

**If the lid is removed the convection current is lost and cook times will increase. Remember – Fill it, Fire it and Forget it!**

**Always use thermometer to check doneness.**

## **General Cooking Instructions Displayed**

### **STEP 1: FILL IT**

- Load the Orion Cooker® with ribs, turkey, chicken, seafood, etc.
- Place charcoal in both the top and bottom rings.
- Wood chips can also be added to the cooking chamber if a smokey flavor is desired.

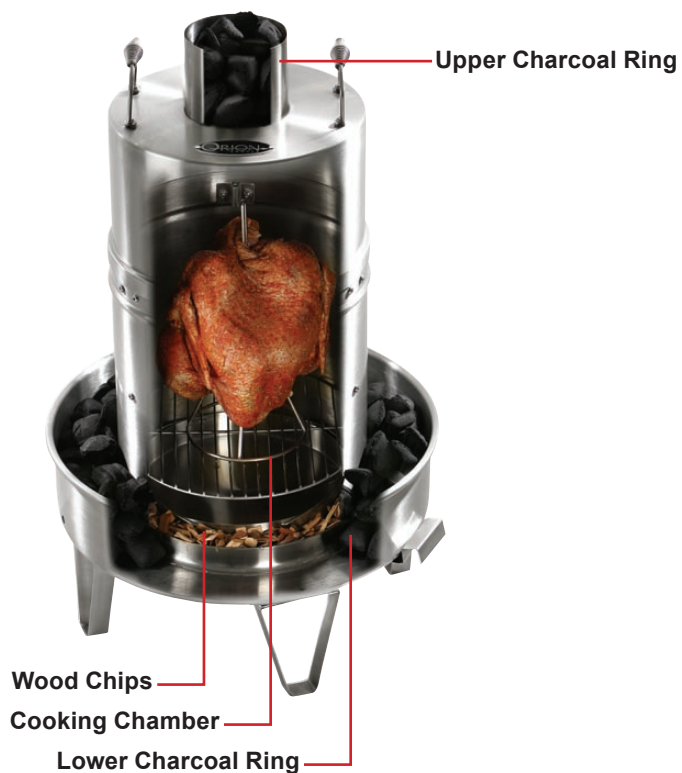

## STEP 2: FIRE IT

- Light the charcoal in both of the charcoal rings.
- Since charcoal is the only heat source, you don't have to worry about any unhealthy fatty oils or hot, messy spills.
- 100% indirect heat prevents carcinogens associated with direct charcoal heat.



## STEP 3: FORGET IT

- After lighting the charcoal, let the Orion Cooker® do the rest of the work.
- Indirect heat from the charcoal will create a constant convection current that circulates within the cooking cylinder, cooking your meat quickly and evenly.
- It's hands off and maintenance free, with no flipping, basting or other troublesome tasks required.



## General Cooking Guide

Product	Weight	Cook Time*
Chicken	3-4 lbs.	1 hour 10 mins
Whole Turkey	20 lbs.	2 hours 15 mins <i>(7 mins per pound)</i>
Whole Turkey	15 lbs	1 hour 45 mins <i>(7 mins per pound)</i>
Prime Rib	7-8 lbs	1 hour 30 mins <i>(12-15 mins per pound)</i>
Beef Brisket	6-7 lbs	3 hours
Beef Brisket	13-14 lbs	4 hours 30 mins
Baby Back Ribs	6 racks	1 hour 15 mins
Baby Back Ribs	3 racks	1 hour 10 mins
Pork Roast	7 lbs.	1 hour 15 mins
Boston Butt	5 lbs.	3 hours 30 mins
Boston Butts	(2) 6-7 lb Butts	4 hours 30 mins
Pork Chops	1.5" cut	35-40 mins
Salmon Filet	2-3 lbs.	30 mins
Chicken Wings	20 wings	45 mins
Chicken Wings	40 wings	1 hour

\*Cook times are approximate

## Recipes

Looking for mouth-watering ideas of what to make on your Orion Cooker®? Try out one of the recommended treats listed below! Or, if you have a recipe you would like to recommend to other Orion Cooker® owners, submit them online to the recipe section of our website — [www.orioncooker.com](http://www.orioncooker.com).

### Boston Butt

Boston Butt 5-8 lbs.                      Salt  
Pepper                                      Garlic Salt

Rub meat with mixture of salt, pepper and garlic salt. Place the meat on the cooking grate inside the cooker. Then, fire up your Orion Cooker® and cook for 3 hours 30 mins, or until done. Check the meat temperature with a thermometer to make sure it is done. Best if cooked with hickory chips.

Diane Yager  
Owensboro, KY

## **Beef Brisket**

12-13 lb brisket  
Seasoning  
Apple Cider Vinegar

Soak the brisket in apple cider vinegar for 6-10 hours

Remove and pat dry with paper towel. Then cut the brisket in half and trim if needed. Apply dry rub. Fill drip pan  $\frac{1}{2}$  full with an even mixture of apple cider vinegar and water. Place wood chips between the drip pan and the inside wall of the cooking cylinder. Place the larger cut brisket on the bottom cooking grate and the other piece on the middle cooking grate. Place 13 lbs of charcoal in the upper and lower charcoal rings. Light the coals and come back in 4 hours and thirty minutes.

Walter H McClanahan  
Humboldt, TN

---

## **Wickers Whole Chicken**

Whole Chicken 3-4 lbs.  
Wickers Marinade  
Honey (to taste)  
Salt & Pepper (to taste)

Marinate chicken in Wickers for two hours. Remove chicken from marinade and inject it with more Wickers. Rub outside of chicken with a mixture of honey, salt and pepper. Place the chicken on the poultry stand and place inside the cooker. Then, fire up your Orion Cooker®. Cook for 1 hour 30 mins, or until done. Use a meat thermometer placed in the middle of the breast to ensure the chicken is thoroughly cooked. Great if cooked with apple chips which add a splendid flavor and crispiness to the skin!

Fargason Erb  
Memphis, TN

## Hush Yo' Mouth Baby Back Ribs

Baby Back Ribs (1-6 racks)	Cayenne Pepper (1 tsp)
Orion's Dry Rub	Garlic (2 cloves)
Apple Cider Vinegar (1 cup)	Salt (to taste)
Ketchup (1 cup)	Tabasco (to taste)
Mustard (5 tbsp)	

Remove the ribs from the package, rinse, and pat dry. Apply Orion's Dry Rub evenly. Affix the ribs to the rib hangers and place in the cooker. Then, fire up your Orion Cooker® and cook for 1 hour 15 mins\*, or until done. Best if cooked with cherry chips.

Barbecue Sauce (optional): Mix vinegar, ketchup, and mustard until it's a light orange color. Add the cayenne pepper, garlic, salt and tabasco sauce to taste. Apply before and after cooking.

\*This time is for six racks of ribs. For fewer ribs the time will be less—3 racks 1hr 10 mins.

Lizzie Powell  
Atlanta, GA

---

## Grandpa Fitz's Turkey

12 to 20 lb. fresh turkey	Paprika (1 tsp)
1/4 stick of butter	Olive Oil (1/4 cup)
Celery Salt (1 tsp)	Lemon Juice (1/4 cup)
Garlic Salt (1 tsp)	Balsamic Vinegar (1/4 cup)
Salt & Pepper (to taste)	Tabasco (1 tsp)
Mustard Powder (1 tsp)	Salt & Pepper (to taste)

Slice butter into 4 to 5 pieces. Use a knife to make slits in skin of turkey breast and legs and slide the butter slices under the skin then rub outer skin with butter. Mix celery salt, garlic salt, mustard powder, table salt and pepper in a small bowl. Rub mixture on outside of turkey to season it. Rub the inside of the turkey cavity with the paprika. Stir the olive oil, lemon juice, balsamic vinegar, Tabasco sauce, salt and pepper together in another small mixing bowl and inject the resulting basting sauce into the breast and thighs of the turkey. Wedge cherry or apple chips between the drip pan and the inside wall of the cooking cylinder. Place the turkey on the poultry stand and place stand on the bottom grate using the lifting

handle. Fire up the cooker and cook for 7 minutes per pound, or until it's done. Use a thermometer to check the temperature of the turkey by placing it in the breast.

Great if cooked with apple or cherry chips, which add a splendid flavor and crispiness to the skin!

Michael Fitzgerald  
West Palm Beach, FL

---

### Simple Turkey

12 to 20 lb. fresh turkey	Olive oil
Lawry's season salt	Rosemary
Fresh black pepper	Paprika

Wash turkey and pat dry. Rub skin with olive oil. Place Turkey back side up in a large foil pan. Apply Lawry's, rosemary, fresh black pepper and paprika to skin. Turn bird over and repeat on the breast side. Wedge cherry or apple chips between the drip pan and the inside wall of the cooking cylinder. Place the turkey cavity side down on the poultry stand and place stand on the bottom grate using the lifting handle. Fire up the cooker and cook for 7 minutes per pound, or until it's done. Use a thermometer to check the temperature of the turkey by placing it in the breast.

Jenny Carbonara  
Cumming, GA

---

### Salmon Filet

Rosemary ¼ cup	Salt ¼ cup
Pepper ¼ cup	3 lemons
Apple wood chips	(3) 2-3lb salmon filets

Mix salt, pepper and rosemary together in small bowl. Cut 9 lemon slices ⅛ inch thick. Evenly spread the salt, pepper mix on the salmon filets. Place lemon slices on top of filets. Add apple chips between cooking cylinder and drip pan. Fill drip pan ¼ full with water. Place cooking grate on top level and place filet on cooking

grate. Add charcoal to upper and lower charcoal rings. Light both upper and lower charcoal rings and check after 30 minutes. Filet will be cooked when meat is flaky.

\*\*For more of a smoke flavor. Place chips between drip pan and cooking cylinder. Without lid on cylinder, light coals in lower charcoal ring. Check cooking cylinder after about 15 minutes. When the chips begin to smoke, place filets on cooking grate. Place lid on cooking cylinder and light the unlit coals in the upper charcoal ring. The filets will be done when the meat is flaky — roughly 30 minutes.

John Underwood  
Highlands, NC

---

### **Standing Rib Roast**

7-8 lb standing rib roast	Lawry's Seasoning™
Garlic Powder	Fresh black pepper

Apply Lawry's™ evenly on all sides of the roast. Lightly sprinkle garlic powder on all sides. Use a pepper mill to distribute coarse fresh cracked pepper on all sides. Place drip pan in the bottom of the cooking cylinder. Place cooking grate on the middle level inside the cylinder. Place meat on middle cooking grate. Place lid on cylinder. Add charcoal to the upper and lower charcoal rings and light the coals. Check after 1.5 hours for doneness. (12-15 minutes per pound depending on how rare you prefer your meat.)

Cam Long  
Macon, GA

---

### **Northeastern Clam Bake**

Fresh clams	5 lbs of Shrimp
Salt	Garlic cloves
1 stick of butter	White wine

Place clams in large stockpot and fill with water to soak. Add salt, garlic and white wine to water. Remove the drip pan from the cooking cylinder. Pour the stockpot liquid into the cooking cylinder until so there's three inches of liquid in the bottom of the cooking cylinder. Throw in 1 stick of butter. Place the lid on the cooking cylinder. Fill the upper and lower charcoal rings with instant light charcoal and light. Wait 15 minutes for the liquid to heat up then remove the lid

and fill the bottom two grates with clams. Put the 5 lbs of shrimp on the top grate and secure the lid. After 15 minutes check the shrimp for doneness and remove. Secure the lid again. After 10 additional minutes remove the lid and using large tongs remove the clams. Note: Clams will open when done, if not open, leave on for another 10 minutes.

Bart Regante  
Toms River, NJ

---

### **“Mello” Boston Butt**

5-8 lb Boston Butt  
3 liters Mello Yellow™  
Orion’s Dry Rub

Pour three liters of Mellow Yellow in large pot. Place Boston Butt in the pot. Using a fork, pierce all sides of the meat. Marinate for 24 hours in refrigerator. After 24 hours remove meat from pot and apply Orion’s Dry Rub evenly over the meat. Add hickory or mesquite chips between cooking cylinder and drip pan. Place meat fat side up on the top level cooking grate. Add charcoal to both the upper and lower charcoal rings. Light and come back in approximately 3.5 hrs. Check for doneness with thermometer. Depending on how much fat is in the meat, cook times may vary.

Adam Brasher  
Gainesville, GA

---

### **Tequila Chicken Wings**

20-40 chicken wings  
Tequila 1 pint  
Lime Juice 2 cups  
Lemon Juice 2 cups  
2 table spoons of salt  
1 tablespoon Tabasco™

Take wings out of package and wash with water. Dry with paper towel. Place selected amount of wings in large zip lock bag. Add one pint of tequila, two cups of lime juice, two cups of lemon juice, two tablespoons of salt and one tablespoon of Tabasco™ to the chicken in the bag. Marinate for 6hrs. Add hickory

chips between the cooking cylinder and drip pan. Place appropriate number of grates inside of cooking cylinder, place chicken wings on grates. Place charcoal in upper and lower charcoal rings. Light and come back at designated time. Check meat for doneness. 20 wings 45 minutes, 40 wings 1 hour.

Rob Howells  
Dublin, CA

---

### **Alder Chicken Halves**

One whole chicken (3-4 lbs)  
Orion's Dry Rub  
Salt

Take whole chicken out of package. Rinse thoroughly. With cutlery shears cut whole chicken in half so there will be a breast on each half. Place the two halves in a large pot. Fill with cold water and pour in a cup of salt. Add ice cubes to water (1 layer of ice cubes on top of water). Place in refrigerator for two hours prior to cooking. When you are ready to cook, take chicken halves out of water and pat dry with paper towel. Sprinkle Orion's Dry Rub evenly over each half. Place Alder chips between cooking cylinder and drip pan. Place cooking grate in cooking cylinder. Place chicken halves cut side down on cooking grate. Place instant light charcoal around upper and lower charcoal rings. Place lid on cooking cylinder. Light and come back in 1 hour and ten minutes. Check meat for doneness.

David Dawkins  
Fayetteville, NC

---

### **White Wine Pork Chops**

(4) 1.5 inch cut boneless pork chops  
White Wine  
Salt  
Garlic Powder  
Onion Powder

Place the 4 pork chops in a large zip lock bag. Pour 4 cups of white wine in the bag. Add 2 teaspoons each of salt, garlic powder and onion powder. Marinate in refrigerator for 3 hours prior to cooking. Remove pork chops from bag and place

on plate. Drizzle marinade on either side of pork chop, save half of marinade for drip pan. Place apple chips between drip pan and cooking cylinder. Pour half of the marinade in the drip pan (the drip pan will already be in the cooking cylinder). Place cooking grate inside of cooking cylinder place 4 pork chops on cooking grate. Add charcoal to both the top and bottom charcoal ring. Light and come back in 35-40 minutes. Check meat for doneness.

\*\*For more of a smoke flavor place chips between the drip pan and cooking cylinder. Without lid on cylinder, light coals in lower charcoal ring. Check cooking cylinder after about 15 minutes. When the chips begin to smoke, place chops on cooking grate. Place lid on cooking cylinder and light the unlit coals in the upper charcoal ring. The chops will be done in 35-40 minutes. Check meat for doneness.

Chip Adair  
Atlanta, GA

---

### **Grey Poupon™ Pork Tenderloin**

4 lb pork tenderloin  
Lemon pepper

Take tenderloin out of package. Rinse thoroughly and pat dry with paper towel. With knife, spread a thin layer of Grey Poupon™ over entire tenderloin. Place alder chips between drip pan and cooking cylinder. Place tenderloin on cooking grate. Add charcoal to upper and lower charcoal ring. Place lid on cooking cylinder. Light and check at 1 hour. Check meat for doneness.

Liz Smith  
Nashville, TN

## Wood Chip Recommendations

ALDER WOOD CHIPS	Use with salmon
APPLE WOOD CHIPS	Use with poultry, pork sausage, pork and lamb
APRICOT WOOD CHIPS	Use with fish, shrimp, chicken, and pork
CHERRY WOOD CHIPS	Use with pork, chicken and turkey
HICKORY WOOD CHIPS	Use with pork, turkey, chicken for smoking brisket and ribs
LEMON WOOD CHIPS	Use with salmon, turkey, chicken and pork
MAPLE WOOD CHIPS	Use with turkey, chicken, pork when smoking brisket or ribs
MESQUITE WOOD CHIPS	Use with fish, pork
PEACH WOOD CHIPS	Use with, pork and chicken
PEAR WOOD CHIPS	Use with pork, turkey and chicken
PECAN WOOD CHIPS	Use with pork

## Meat Doneness Table

Veal, lamb and beef
Medium Rare: 145 degrees
Medium: 160 degrees
Well Done: 170 degrees
Pork
Medium: 160 degrees
Well Done: 170 degrees
Poultry
180 degrees

## Frequently Asked Questions:

- 1. Are there any flames on the inside of the Orion Cooker®?*

No, the heat source comes from coals located at two areas on the outside of the cooker.
- 2. What does the fire on the top of the cooker accomplish?*

The fire on the top is part of the patent pending cooking technology that produces the convection current inside the cooking cylinder.
- 3. Do the handles on the lid get hot?*

No, the handles are made out of coiled steel which dissipates heat. They are similar to handles found on a "Dutch oven".
- 4. Where are the chips placed that provide the smoke?*

The chips are placed between the drip pan and the inside wall of the cooking cylinder. Do not place wood chips underneath the drip pan. The heat from the charcoal in the lower charcoal ring causes them to smoke when they are up against the inside wall of the cooking cylinder.
- 5. What are the attachments constructed out of—stainless steel or aluminum?*

The attachments are manufactured out of food grade stainless steel. They are dishwasher safe, will not rust and very sturdy.
- 6. What comes with the Orion Cooker® when it is purchased?*

The unit will arrive to you with three attachments: three rib hangers, three cooking grates and a turkey post and lifting handle. Along with the attachments you will receive a cookbook and cooking manual that will walk you through all of the steps while cooking on the Orion Cooker®.
- 7. How do you remove the ashes from the cooker?*

To remove the ashes from the lower ring, simply slide the ash door out and start scraping the coals out with the door. We recommend that you purchase a tin pan to scrape the used ashes into.
- 8. How do you know when the food is done?*

The cook times for the product will be listed in the cookbook/manual. These times are accurate; however, please check all meat with a thermometer to ensure that it is done.
- 9. What type of steel is the Orion Cooker® made out of?*

The Orion Cooker® and all of the attachments are 100% food grade stainless steel. After using the Orion Cooker® several times, the steel will begin to darken. This is due to the smoke on the inside of the cooking cylinder as well

as the heat/ash from the coals on the outside. This will in no way diminish the quality or performance of the Orion Cooker®.

10. *Do I need to soak wood chips prior to cooking/smoking?*

No the wood chips do not need to be soaked. The cooking cylinder is completely enclosed so very little smoke will escape from the cylinder. The chips will not need to be replaced, they will last the duration of the cook.

11. *Can you put liquid in the drip pan or does it have to stay dry?*

We only recommend adding liquid to the drip pan for beef briskets, fish and seafood. Because the meat is completely enclosed in the cooking cylinder, moisture from the meat drips down into the pan causing it to steam and preventing it from drying out.

12. *Do I need to cook on the Orion Cooker® prior to cooking any product?*

It's not necessary, however, we do strongly recommend washing all accessories prior to cooking with them.

13. *Should I wash the attachments prior to the first cook on the Orion Cooker®?*

Yes, we recommend that you wash all of the attachments prior to cooking any meat on the Orion Cooker®. All of the attachments are dishwasher safe. So we recommend that prior to the first cook with meat that you wash all of the attachments in the dishwasher.

14. *Do you recommend instant light charcoal or regular charcoal?*

We recommend that you use instant light charcoal. This will make the cooking process easier. Also, the cook times will be more accurate using instant light charcoal.

15. *If I remove the lid before the designated time, will this affect the cooking?*

Yes, if you remove the lid before the designated cook time the cook times will be affected. This will disrupt the convection current and allow the heat to escape the cooking cylinder.

16. *Does cold effect the cook times?*

Not to our knowledge, Orion Cooker® has cooked in temperatures ranging from 35-40 degrees and there was no change in the cook time.

17. *Does wind effect cooking on the Orion Cooker®?*

Yes, substantial winds will cause the briquettes to burn faster than normal. In this situation, additional coals might be needed to complete the cook.

***Remember – Fill it, Fire it and Forget it!***