

This Owner's Manual is provided and hosted by [Appliance Factory Parts](http://Appliance Factory Parts).



# LG AKWW0363UA0 Owner's Manual

[Shop genuine replacement parts for LG  
AKWW0363UA0](#)

## Exploded View

AKWW0603UA0  
AKWW0483UA0  
AKWW0363UA0

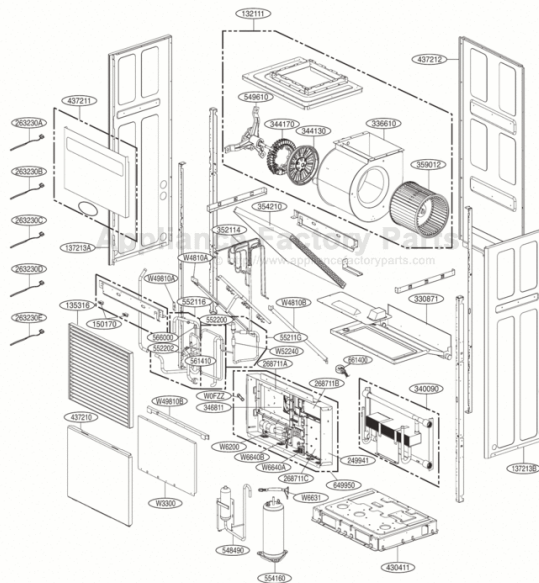

Copyright ©2009 LG Electronics, Inc. All right reserved.  
Only for training and service purposes

- 6 -

LGE Internal Use Only

[Find Your LG Air Conditioner Parts - Select From 2328 Models](#)

----- Manual continues below -----



website <http://www.lgservice.com>

LG

# LG Water Cooled Package Air Conditioner

## **OWNER'S MANUAL**

**MODELS: AKWW0603UA0  
AKWW0483UA0  
AKWW0363UA0**

ENGLISH

FRANÇAIS

ESPAÑOL

### **IMPORTANT**

- Please read this owner's manual carefully and thoroughly before installing and operating your room air conditioner.
- Please retain this owner's manual for future reference after reading it thoroughly.

# TABLE OF CONTENTS

**Safety Precautions** .....3

**Prior to Operation** .....7

**Introduction** .....8

**Maintenance and Service** .....15



## FOR YOUR RECORDS

Write the model and serial numbers here:

**Model #** \_\_\_\_\_

**Serial #** \_\_\_\_\_

You can find them on a label on the side of each unit.

**Dealer's Name** \_\_\_\_\_

**Date Purchased** \_\_\_\_\_

■ Staple your receipt to this page in the event you need it to prove date of purchase or for warranty issues.



## READ THIS MANUAL

Inside you will find many helpful hints on how to use and maintain your air conditioner properly. Just a little preventive care on your part can save you a great deal of time and money over the life of your air conditioner.

You'll find many answers to common problems in the chart of troubleshooting tips. If you review our chart of

**Troubleshooting Tips** first, you may not need to call for service at all.



## PRECAUTION

- Contact the authorized service technician for repair or maintenance of this unit.
- Contact the installer for installation of this unit.
- The air conditioner is not intended for use by young children or invalids without supervision.
- Young children should be supervised to ensure that they do not play with the air conditioner.
- When the power cord is to be replaced, replacement work shall be performed by authorized personnel only using only genuine replacement parts.
- Installation work must be performed in accordance with the National Electric Code by qualified and authorized personnel only.

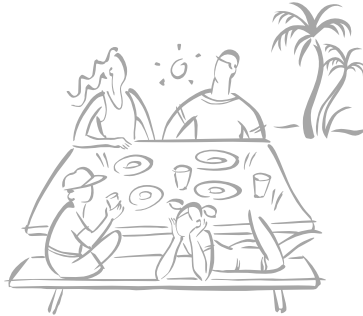

# Safety Precautions

To prevent injury to the user or other people and property damage, the following instructions must be followed.

- Be sure to read before installing the air conditioner.
- Be sure to observe the cautions specified here as they include important items related to safety.
- Incorrect operation due to ignoring instruction will cause harm or damage. The seriousness is classified by the following indications.

<b>⚠ WARNING</b> This symbol indicates the possibility of death or serious injury.
<b>⚠ CAUTION</b> This symbol indicates the possibility of injury or damage to properties only.

■ Meanings of symbols used in this manual are as shown below.

	<b>Be sure not to do.</b>
	<b>Be sure to follow the instruction.</b>

## ⚠ WARNING

### ■ Installation

**Do not place the power cord near a heater.**

- It may cause fire and electric shock.

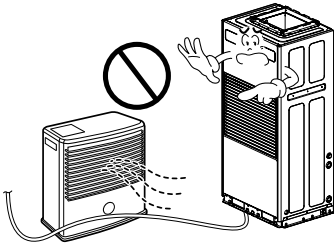

**Do not use the power cord near flammable gas or combustibles such as gasoline, benzene, thinner, etc.**

- It may cause explosion or fire.

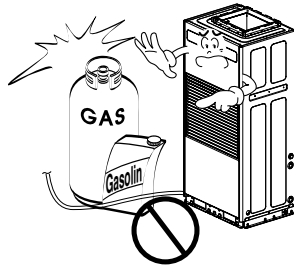

**Do not disassemble or modify products.**

- It may cause failure and electric shock.

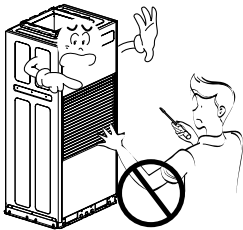

■ Operation

**Do not operate or stop the unit by inserting or pulling out the power.**

- It will cause electric shock or fire due to heat generation.

**Do not damage or use an unspecified power cord.**

- It will cause electric shock or fire.

**Do not modify power cord length.**

- It will cause electric shock or fire due to heat generation.

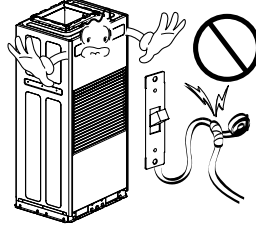
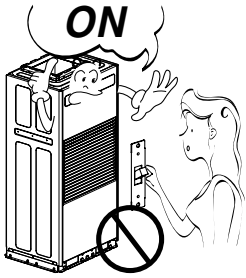

**Always plug into a grounded outlet.**

- No grounding may cause electric shock (See Installation Manual).

**Unplug the unit if strange sounds, odors, or smoke come from it.**

- Otherwise it may cause fire and electric shock accident.

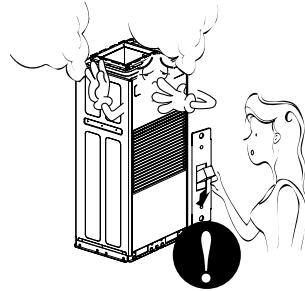
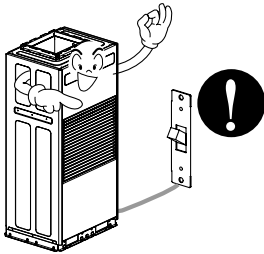

**Do not operate with wet hands or in damp environment.**

- It will cause electric shock.

**Do not allow water to run into electric parts.**

- It will cause failure of machine or electric shock.

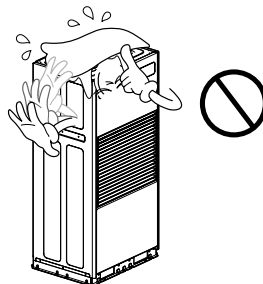
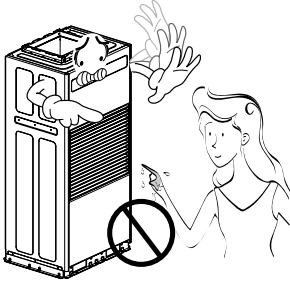

**Leave the door closed while the air conditioner is running.**

- It is not designed to cool the entire house.

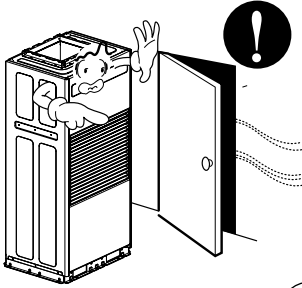

**Ventilate before operating air conditioner when gas goes out.**

- It may cause explosion, fire, and burn.

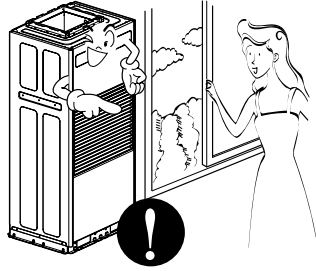

ENGLISH

**CAUTION**

**Installation**

**Never touch the metal parts of the unit when removing the filter.**

- They are sharp and may cause injury.

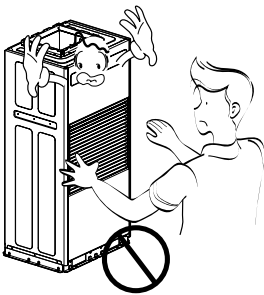

**Do not block the inlet or outlet.**

- It may cause failure of appliance or accident.

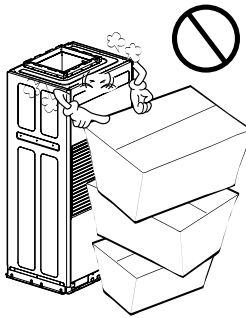

**Be cautious not to touch the sharp edges when installing.**

- It may cause injury.

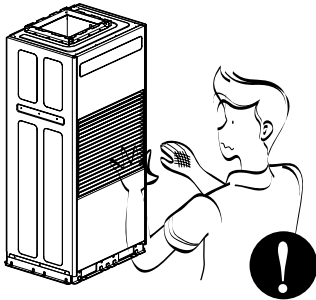

**Turn off the main power switch when not using it for a long time.**

- Prevent accidental startup and the possibility of injury.

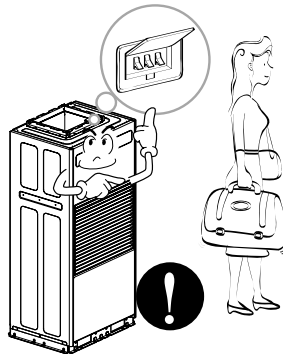

**Do not place heavy object on the power cord and take care so that the cord should not be pressed.**

- There is danger of fire or electric shock.

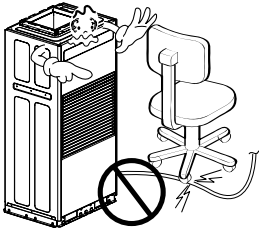

**If water enters the product, turn off the the power switch of the main body of appliance. Contact service center after taking the power-plug out from the socket.**

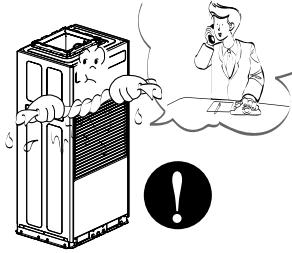

**Do not clean the air conditioner with water.**

- Water may enter the unit and degrade the insulation. It may cause an electric shock.

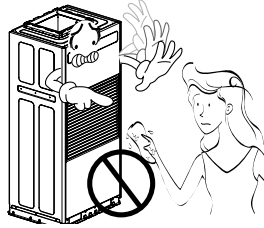

**Turn off the power and breaker firstly when cleansing the unit.**

- Since the fan rotates at high speed during operation, it may cause injury.

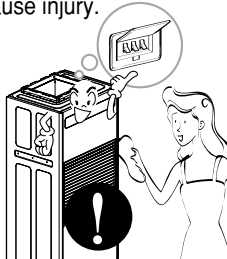

**Do not put a pet or house plant where it will be exposed to direct air flow.**

- This could injure the pet or plant.

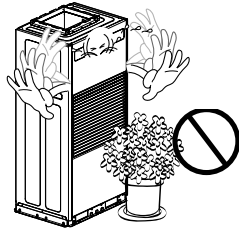

**Do not use this appliance for special purposes such as pets, foods, precision machinery, or objects of art.**

- It is an air conditioner, not a precision refrigeration system.

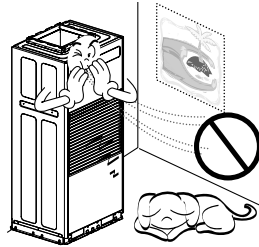

**Always insert the filter securely. Clean it every two weeks.**

- Operation without filters will cause failure.

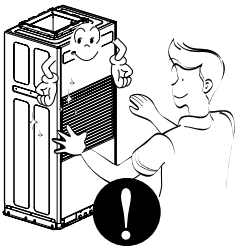

**Use a soft cloth to clean. Do not use wax, thinner, or a strong detergent.**

- The appearance of the air conditioner may deteriorate, change color, or develop surface flaws.

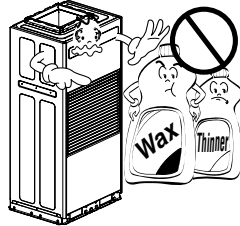

**Do not drink water drained from air conditioner. / Do not direct airflow at room occupants only.**

- It contains contaminants and will make you sick. / This could damage your health.

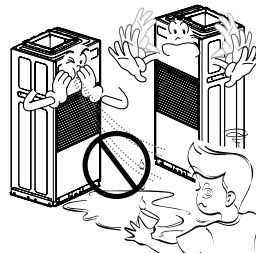

# Prior to Operation

## Preparing for operation

1. Contact an installation specialist for installation.
2. Plug in the power plug properly.
3. Use a dedicated circuit.
4. Do not use an extension cord.
5. Do not start/stop operation by plugging/unplugging the power cord.
6. If the cord/plug is damaged, replace it with only an authorized replacement part.

## Usage

1. Being exposed to direct airflow for an extended period of time could be hazardous to your health. Do not expose occupants, pets, or plants to direct airflow for extended periods of time.
2. Due to the possibility of oxygen deficiency, ventilate the room when used together with stoves or other heating devices.
3. Do not use this air conditioner for non-specified special purposes (e.g. preserving precision devices, food, pets, plants, and art objects). Such usage could damage the items.

## Cleaning and maintenance

1. Do not touch the metal parts of the unit when removing the filter. Injuries can occur when handling sharp metal edges.
2. Do not use water to clean inside the air conditioner. Exposure to water can destroy the insulation, leading to possible electric shock.
3. When cleaning the unit, first make sure that the power and breaker are turned off. The fan rotates at a very high speed during operation. There is a possibility of injury if the unit's power is accidentally triggered on while cleaning inner parts of the unit.

## Service

For repair and maintenance, contact your authorized service dealer.

## Operating Temperature(unit: Fahrenheit , °F)

COOLING MODE				HEATING MODE			
INDOOR		WATER		INDOOR		WATER	
Max.	Min.	Max.	Min.	Max.	Min.	Max.	Min.
89.6	64.4	104	59	69.8	50	104	59

# Introduction

## Symbols used in this Manual



This symbol alerts you to the risk of electric shock.



This symbol alerts you to hazards that could cause harm to the air conditioner.

**NOTICE**

This symbol indicates special notes.

## Features

AKWW0603UA0  
AKWW0483UA0  
AKWW0363UA0

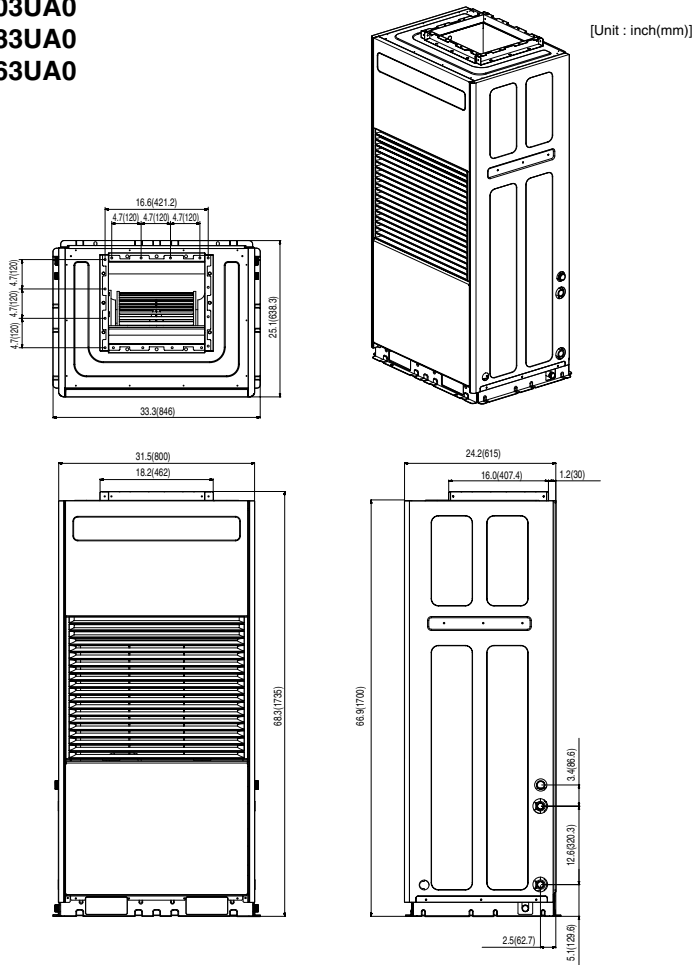

## Pre-Start-up Checklist

ENGLISH

**Before energizing the unit, the following system devices must be checked:**

- Is the high voltage power supply correct and in accordance with the nameplate ratings?
- Is the field wiring and circuit protection the correct size?
- Is the low voltage control circuit wiring correct per the unit wiring diagram?
- Is the piping system clean/complete and correct? (A recommendation of all system flushing of debris from the water-to-refrigerant heat exchanger, along with air purging from the water-to-refrigerant heat exchanger be done in accordance with the Closed-Loop Source Heat Pump Systems Installation Guide).
- Is vibration isolation provided? (i.e. unit isolation pad, hose kits)
- Is unit serviceable? (See clearance specifications).
- Are the low/high-side pressure temperature caps secure and in place?
- Are all the unit access panels secure and in place?
- Is the thermostat in the OFF position?
- Is the water flow established and circulating through all the units?
- Is the duct work (if required) correctly sized, run, taped, insulated and weather proofed with proper unit arrangement?
- Is the condensate line properly sized, run, trapped and pitched?
- Does the indoor blower turn freely without rubbing?
- Has all work been done in accordance with applicable local and national codes?
- Has heat transfer fluid been added in the proper mix to prevent freezing in closed system application?
- Have the chassis isolation rails been released?
- Is there a good seal between the front air panel and the coil?

## Maintenance

### - Preventive Maintenance

Maintenance on the unit is simplified with the following preventive suggestions: Filter maintenance must be performed to assure proper operation of the equipment. Filters should be inspected at least every three months, and replaced when it is evident they are dirty.

Check the contactors and relays within the control panel at least once a year. It is good practice to check the tightness of the various wiring connections within the control panel. A strainer (60 mesh or greater) must be used on an open loop system to keep debris from entering the unit heat exchanger and to ensure a clean system. For units on well water, it is important to check the cleanliness of the water-to-refrigerant heat exchanger. Should it become contaminated with dirt and scaling as a result of bad water, the heat exchanger will have to be back flushed and cleaned with a chemical that will remove the scale. This service should be performed by an experienced service person.

### - Hazardous Chemicals

Coil cleaning agents can be either acidic or highly alkaline. Handle chemical carefully. Proper handling should include goggles or face shield, chemical resistant gloves, boots, apron or suit as required. For personal safety, refer to the cleaning agent manufacturers Materials Safety Data Sheet and follow all recommended safe handling practices. Failure to follow all safety instructions could result in death or serious injury. It should be noted that the water quality should be checked periodically. See the following water quality table.

Scaling	Calcium and magnesium(total hardness)	Less than 350 ppm
Corrosion	pH	7 ~ 9.5
	Hydrogen Sulfide	Less than 1 ppm
	Sulfates	Less than 25 ppm
	Chlorides	Less than 125 ppm
	Carbon Dioxide	Less than 75 ppm
	Total dissolved solids(TDS)	Less than 1000 ppm
Biological Growth	Iron Bacteria	Low
Erosion	Suspended Solids	Low

## Remote control operation



ENGLISH

## Functions

### Primary functions

- Remote control and monitoring of an RRV... controller
- Parameter adjustments by installer
- Room temperature measurement

### Operator functions

- Time clock operation
- Comfort temperature setpoint adjustment
- Energy saving temperature setpoints adjustment
- Auto timer selection
- Fan speed selection
- Zone selection and settings (only for RRV controllers with zone outputs)
- Display of operating mode, temperature, time, fan speed and zone values.

## Operating elements



### Legend

1. LED for heat/cool output status
2. LCD display with EL backlight for control and monitoring of modes, setpoints, zone conditions etc
3. Operating mode selection – Comfort, energy saving and auto timer (Day/Night zone selection for Duo-zone application)
4. Temporary setpoint and value increase/decrease
5. System off and fan speed control
6. Heat, cool, heat/cool changeover and ventilation only selection
7. Time and weekday setting
8. Auto timer schedule setting
9. Zone output selection
10. Permanent comfort and energy saving setpoints (Day/Night/Both setpoints for Duo-zone application)
11. Button for confirming values and scrolling through parameter sets

## LCD display

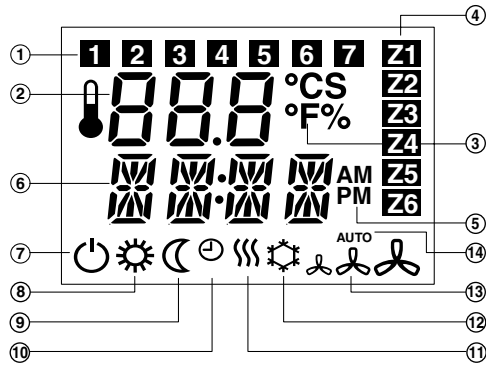

ENGLISH

**Legend**

1. Day indication
2. Actual temperature
3. Fahrenheit/Celsius
4. Zone indication (Duo-switch application)
5. AM/PM indication
6. Time display
7. System off
8. Comfort mode (Day zone in Duo-zone application)
9. Energy saving mode (Night zone in Duo-zone application)
10. Auto timer mode
11. Heating mode
12. Cooling mode
13. Fan speed indication (low, medium and high)
14. Auto fan mode

## Commissioning notes

### Response on start-up

When powering up, the QAX850 will display all LCD icons for approximately 3 seconds and then the software version number for another 3 seconds. It will then revert to normal display. The time segments will be blinking if time needs to be set. Set time as per operation instructions. There will be a delay before operation commences due to polling of all values.

### Sensor calibration

Generally there is no need to calibrate sensor; however the displayed room temperature on the LCD can be calibrated if there is any discrepancy from the actual temperature measured with a certified thermometer. Calibration function can be accessed by pressing the ▲ and ▼ buttons simultaneously for 5 seconds. Displayed value can then be adjusted via the same buttons in 0.1K steps. Range is +/- 3K.

### Commissioning

Initial application set-up of RRV controller to match the connected HVAC equipment is made by the selection of dip switch positions. Dip switches are located on the top of the RRV controller. Further settings can be made via the QAX850 by modifying parameters as per list below. Default values are dependant on application selected and RRV controller model. Refer to installation/commissioning guide for set-up details and application sheets for default parameter values.

To access parameters press the ▲ and ▼ buttons simultaneously for 3 seconds, then within 2 seconds press the ▼ button for 3 seconds and release. Parameters cannot be accessed if system is in off mode.

# Maintenance and Service

*When the air conditioner is not GOING to be used for a long time.*

ENGLISH

**When it is not going to be used for a long time.**

- 1 Operate the air conditioner at the following settings for 2 to 3 hours.
  - Type of operation: Fan operation mode.
  - This will dry out the internal mechanisms.
- 2 Turn off the breaker.

**CAUTION:** Turn off the breaker when the air conditioner is not going to be used for a long time.  
Dirt may collect and may cause a fire.

**When the air conditioner is to be used again.**

- 1 Clean the air filter and install it in the indoor unit.
- 2 Check that the air inlet and outlet of the indoor/outdoor unit are not blocked.
- 3 Check that the ground wire is connected correctly. It may be connect to the indoor unit side.

**Helpful information**

The air filters and your electric bill.  
If the air filters become clogged with dust, the cooling capacity will drop, and 6% of the electricity used to operate the air conditioner will be wasted.

## Operation Tips

<p><b>Do not overcool the room.</b></p> <p>This is not good for the health and wastes electricity.</p>	<p><b>Keep blinds or curtains closed.</b></p> <p>Do not let direct sunshine enter the room when the air conditioner is in operation.</p>	<p><b>Keep the room temperature uniform.</b></p> <p>Adjust the vertical and horizontal airflow direction to ensure a uniform temperature in the room.</p>
<p><b>Make sure that the doors and windows are shut tight.</b></p> <p>Avoid opening doors and windows as much as possible to keep the cool air in the room.</p>	<p><b>Clean the air filter regularly.</b></p> <p>Blockages in the air filter reduce the airflow and lower cooling and dehumidifying effects. Clean at least once every two weeks.</p>	<p><b>Ventilate the room occasionally.</b></p> <p>Since windows are kept closed, it is a good idea to open them and ventilate the room now and then.</p>

## Troubleshooting

Check the following points before requesting repairs or service.... If the malfunction persists, please contact your dealer.

Case	Explanation
The air conditioner does not operate.	<ul style="list-style-type: none"> <li>• Have you made a mistake in timer operation?</li> <li>• Has the fuse blown or has the circuit breaker been tripped?</li> </ul>
The room has a peculiar odor.	<ul style="list-style-type: none"> <li>• Check that this is not a damp smell exuded by the walls, carpet, furniture or cloth items in the room.</li> </ul>
It seems that condensation is leaking from the air conditioner.	<ul style="list-style-type: none"> <li>• Condensation occurs when the airflow from the air conditioner cools the warm room air.</li> </ul>
Air conditioner does not operate for about 3 minutes when restart.	<ul style="list-style-type: none"> <li>• This is the protector of the mechanism.</li> <li>• Wait about three minutes and operation will begin.</li> </ul>
Does not cool or heat effectively.	<ul style="list-style-type: none"> <li>• Is the air filter dirty? See air filter cleaning instructions.</li> <li>• The room may have been very hot when the room air conditioner was first turned on. Allow time for it to cool down.</li> <li>• Has the setting temperature been set incorrectly?</li> <li>• Are the indoor unit's air inlet or outlet vents obstructed?</li> </ul>
The air conditioner operation is noisy.	<ul style="list-style-type: none"> <li>• For a noise that sounds like water flowing.                             <ul style="list-style-type: none"> <li>-This is the sound of freon flowing inside the air conditioner unit.</li> </ul> </li> <li>• For a noise that sounds like the compressed air releasing into atmosphere.                             <ul style="list-style-type: none"> <li>-This is the sound of the dehumidifying water being processed inside the air conditioning unit.</li> </ul> </li> </ul>
Crack sound is heard.	<ul style="list-style-type: none"> <li>• This sound is generated by the expansion/contraction of the inlet grille, etc. due to changes of temperature.</li> </ul>
Remote control display is faint, or no display at all.	<ul style="list-style-type: none"> <li>• Has the circuit breaker been tripped?</li> <li>• Are the batteries inserted in the opposite (+) and (-) directions?</li> </ul>

## Cleaning the air filter

### 1) Pull out the suction grill.

- When you pull the top part of the suction grill lightly forward, the suction grill can be opened. Loosen the connecting hook attached on the suction grill. Then the suction grill will be separated.

### 2) Pull out the air filter

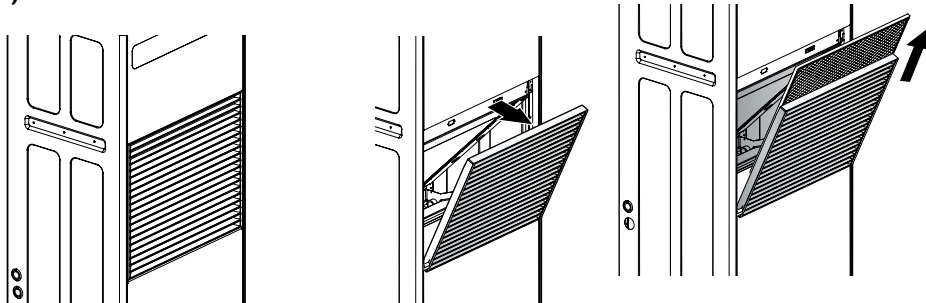

ENGLISH

### 3) Wash air filter with warm water and a mild detergent. Rinse and dry it. Replace it in place.

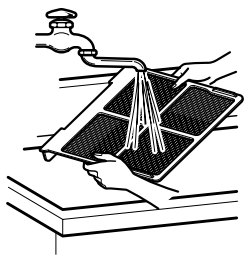

**CAUTION:** Be careful! Do not touch the heat exchanger fins. It may cause injury.





P/No.: MFL30215205

Printed in Korea

**After reading this manual, keep it in a place easily accessible to the user for future reference.**