



website <http://www.lgservice.com>
e-mail <http://www.lgservice.com/techsup.html>

LG

LG Water Cooled Package Air Conditioner

INSTALLATION MANUAL

**MODELS: AKWW0603UA0
AKWW0483UA0
AKWW0363UA0**

ENGLISH

FRANÇAIS

ESPAÑOL

IMPORTANT

- Please read this instruction sheet completely before installing the product.
- When the power cord is damaged, replacement work shall be performed by authorized personnel only.
- Installation work must be performed in accordance with the national wiring standards by authorized personnel only.
- Please retain this owner's manual for future reference after reading it thoroughly.

TABLE OF CONTENTS

<i>Installation Requirements</i>	<i>Required Parts</i>	<i>Required Tools</i>
Safety Precautions4	<input type="checkbox"/> Home VAV Main Controller	<input type="checkbox"/> Screw driver
	<input type="checkbox"/> Room Control Wall Thermostat	<input type="checkbox"/> Electric drill
Introduction8	<input type="checkbox"/> Static Pressure Sensor	<input type="checkbox"/> Specified torque wrenches
Symbols Used in this Manual8	<input type="checkbox"/> Water Valve	<input type="checkbox"/> Spanner
Features8	<input type="checkbox"/> Water Valve Actuator	<input type="checkbox"/> Ohmmeter
	<input type="checkbox"/> VAV Box With Actuator	<input type="checkbox"/> Ammeter
Installation9	<input type="checkbox"/> Fitting Linkage	<input type="checkbox"/> Thermometer
Installation Parts(Optional).....9		<input type="checkbox"/> Horizontal meter
Installation Tools10		<input type="checkbox"/> Pipe wrench
Connect the cable25		

WATER-SOURCE HEAT PUMP INSTALLATION INSTRUCTIONS

IMPORTANT!

Please read this instruction sheet completely before installing the product.

This air conditioning system meets strict safety and operating standards. As the installer or service person, it is an important part of your job to install or service the system so it operates safely and efficiently.

WARNING

- Installation or repairs made by unqualified persons can result in hazards to you and others. Installation **MUST** conform with local building codes or, in the absence of local codes, with the National Electrical Code NFPA 70/ANSI C1-1993 or current edition and Canadian Electrical Code Part1 CSA C.22.1.
- The information contained in the manual is intended for use by a qualified service technician familiar with safety procedures and equipped with the proper tools and test instruments.
- Failure to carefully read and follow all instructions in this manual can result in equipment malfunction, property damage, personal injury and/or death.

CAUTION: Improper installation, adjustment, alteration, service or maintenance can void the warranty. The weight of the condensing unit requires caution and proper handling procedures when lifting or moving to avoid personal injury. Use care to avoid contact with sharp or pointed edges.

Safety Precautions

- Always wear safety eye wear and work gloves when installing equipment.
- Never assume electrical power is disconnected. Check with meter and equipment.
- Keep hands out of fan areas when power is connected to equipment.
- R-410A causes frostbite burns.
- R-410A is toxic when burned.

NOTE TO INSTALLING DEALER: The Owners Instructions and Warranty are to be given to the owner or prominently displayed near the indoor Furnace/Air Handler Unit.

WARNING

When wiring:

Electrical shock can cause severe personal injury or death. Only a qualified, experienced electrician should attempt to wire this system.

- Do not supply power to the unit until all wiring and tubing are completed or reconnected and checked.
- Highly dangerous electrical voltages are used in this system. Carefully refer to the wiring diagram and these instructions when wiring. Improper connections and inadequate grounding can cause accidental injury or death.
- Ground the unit following local electrical codes.
- Connect all wiring tightly. Loose wiring may cause overheating at connection points and a possible fire hazard.

When transporting:

Be careful when picking up and moving the units. Get a partner to help, and bend your knees when lifting to reduce strain on your back. Sharp edges or thin aluminum fins on the air conditioner can cut your finger. Move the product more than two people, Improper moving may result in injury.

When servicing

- Turn the power OFF at the main power box(mains) before opening the unit to check or repair electrical parts and wiring.
- Keep your fingers and clothing away from any moving parts.
- Clean up the site after you finish, remembering to check that no metal scraps or bits of wiring have been left inside the unit being serviced.

Safety Precautions



To prevent injury to the user or other people and property damage, the following instructions must be followed.

- Be sure to read before installing the air conditioner.
- Be sure to observe the cautions specified here as they include important items related to safety.
- Incorrect operation due to ignoring instruction will cause harm or damage. The seriousness is classified by the following indications.

⚠ WARNING This symbol indicates the possibility of death or serious injury.

⚠ CAUTION This symbol indicates the possibility of injury or damage to properties only.

- Meanings of symbols used in this manual are as shown below.

	Be sure not to do.
	Be sure to follow the instruction.

⚠ WARNING

■ Installation

Do not place the power cord near a heater.

- It may cause fire and electric shock.
(See features section)

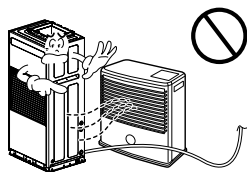

Do not use the power cord near flammable gas or combustibles such as gasoline, benzene, thinner, etc.

- It may cause explosion or fire.

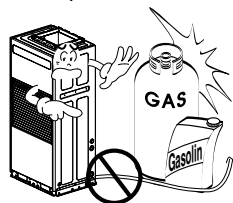

Do not disassemble or modify products.

- It may cause failure and electric shock.
(See features section)

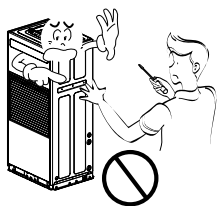

■ Operation

Plug in the power plug Do not operate or stop the unit by inserting or pulling out the power.

- It will cause electric shock or fire due to heat generation.

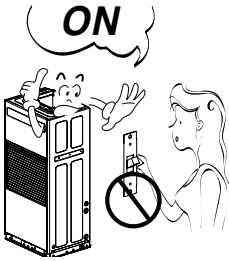

Do not damage or use an unspecified power cord.

- It will cause electric shock or fire.

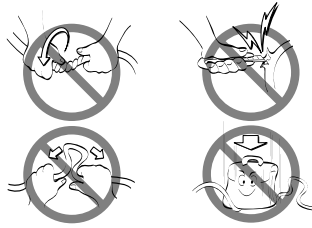

Do not modify power cord length.

- It will cause electric shock or fire due to heat generation.

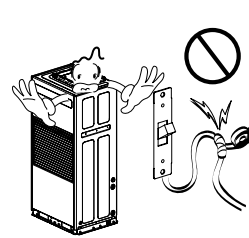

Always plug into a grounded outlet.

- No grounding may cause electric shock (See Installation Manual).

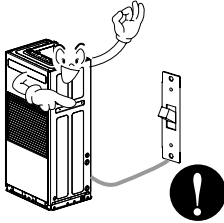

Unplug the unit if strange sounds, odors, or smoke come from it.

- Otherwise it may cause fire and electric shock accident.

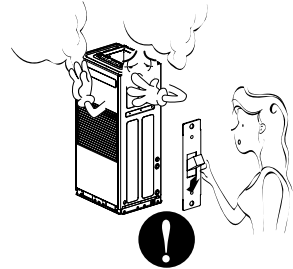

Do not operate with wet hands or in damp environment.

- It will cause electric shock.

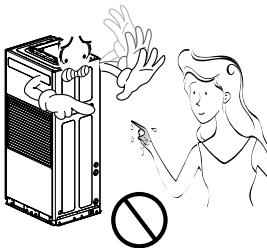

Do not allow water to run into electric parts.

- It will cause failure of machine or electric shock.

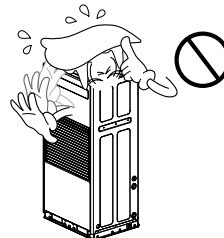

Leave the door closed while the air conditioner is running.

- It is not designed to cool the entire house.

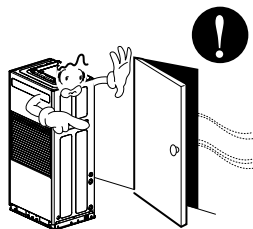

Ventilate before operating air conditioner when gas goes out.

- It may cause explosion, fire, and burn.

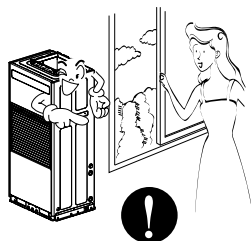

CAUTION

Installation

Never touch the metal parts of the unit when removing the filter.

- They are sharp and may cause injury.

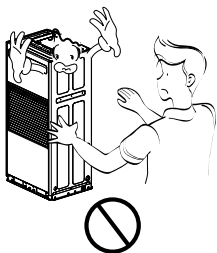

Do not block the inlet or outlet.

- It may cause failure of appliance or accident.

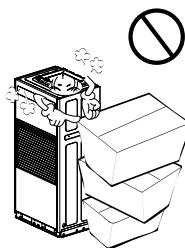

Be cautious not to touch the sharp edges when installing.

- It may cause injury.

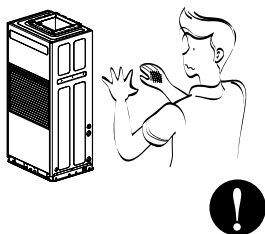

Turn off the main power switch when not using it for a long time.

- Prevent accidental startup and the possibility of injury.

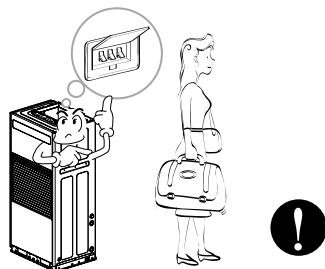

Do not place heavy object on the power cord and take care so that the cord should not be pressed.

- There is danger of fire or electric shock.

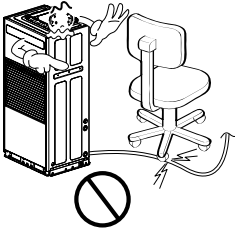

If water enters the product, turn off the the power switch of the main body of appliance. Contact service center after taking the power-plug out from the socket.

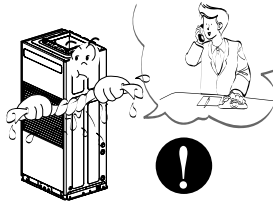

Do not clean the air conditioner with water.

- Water may enter the unit and degrade the insulation. It may cause an electric shock.

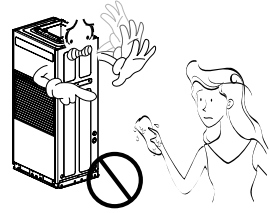

Turn off the power and breaker firstly when cleansing the unit.

- Since the fan rotates at high speed during operation, it may cause injury.

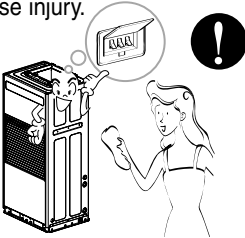

Do not put a pet or house plant where it will be exposed to direct air flow.

- This could injure the pet or plant.

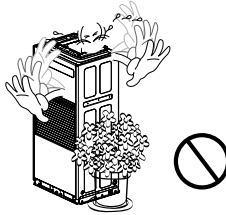

Do not use this appliance for special purposes such as pets, foods, precision machinery, or objects of art.

- It is an air conditioner, not a precision refrigeration system.

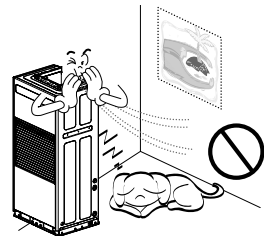

Always insert the filter securely. Clean it every two weeks.

- Operation without filters will cause failure.

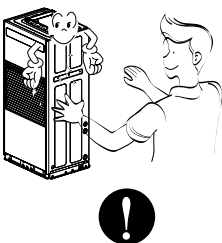

Use a soft cloth to clean. Do not use wax, thinner, or a strong detergent.

- The appearance of the air conditioner may deteriorate, change color, or develop surface flaws.



Do not drink water drained from air conditioner. / Do not direct airflow at room occupants only.

- It contains containments and will make you sick. / This could damage your health.

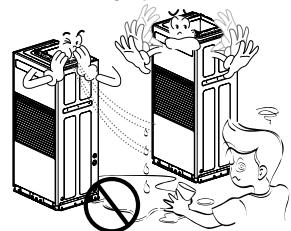

Introduction

Symbols Used in this Manual



This symbol alerts you to the risk of electric shock.



This symbol alerts you to hazards that could cause harm to the air conditioner.

NOTICE

This symbol indicates special notes.

Features

AKWW0603UA0

AKWW0483UA0

AKWW0363UA0

[Unit : inch(mm)]

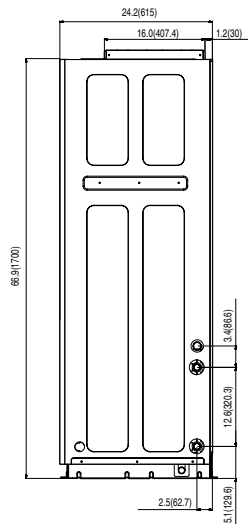
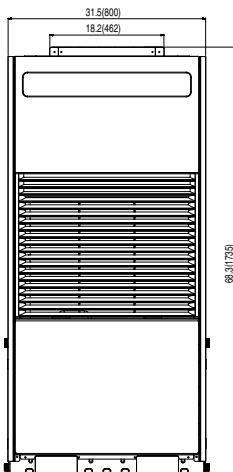
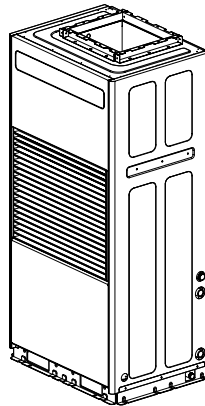
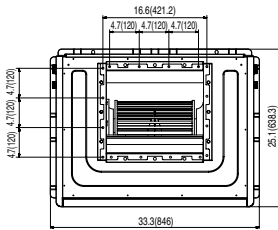

Installation

Read completely, then follow step by step.

Installation Parts(Accessory)



Home VAV
Main Controller



Room Control Wall
Thermostat



Static Pressure
Sensor



Water Valve



Water Valve
Actuator



VAV Box
With Actuator







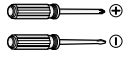

Fitting Linkage

Accessory List

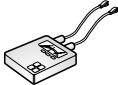
Model	Description	Dimension (W x H x D Inch) & Spec
ACX32	Home VAV Main Controller	11 3/16"x6 3/16x2 1/8", ACV(or DC 26~35V)
QAX850	Room Control Wall Thermostat	3 13/16"x4 11/16"x7/8"
QBM66.201	Static Pressure Sensor	3 5/8"x3 11/16"x1 7/8", 200Pa(M/Range)
VVP45.25-6.3	Water Valve(3RT,4RT)	3 1/8"x4 5/16", 300kPa
VVP45.25-10	Water Valve(5RT)	4 1/8"x5 5/16", 300kPa
SSB61	Water Valve Actuator(3RT,4RT)	3 5/16"x3 3/16"x1 7/8", AC24V, 200N
SSC61	Water Valve Actuator(5RT)	4 5/16"x5 5/16"x1 7/8", AC24V, 200N
VB6	VAV Box w/ Actuator- Diameter*Length 6*9 1/2"	6ø x L9 1/2", GQX161.1E(Actuator)
VB7	VAV Box w/ Actuator- Diameter* Length 7*9 1/2"	7ø x L9 1/2", GQX161.1E(Actuator)
VB8	VAV Box w/ Actuator- Diameter* Length 8*9 1/2"	8ø x L9 1/2", GQX161.1E(Actuator)
VB9	VAV Box w/ Actuator- Diameter* Length 9*9 1/2"	9ø x L9 1/2", GQX161.1E(Actuator)
VB10	VAV Box w/ Actuator- Diameter* Length 10*9 1/2"	10ø x L9 1/2", GQX161.1E(Actuator)
VB12	VAV Box w/ Actuator- Diameter* Length 12*9 1/2"	12ø x L9 1/2", GQX161.1E(Actuator)
VB14	VAV Box w/ Actuator- Diameter* Length 14*9 1/2"	14ø x L9 1/2", GQX161.1E(Actuator)
VB16	VAV Box w/ Actuator- Diameter* Length 16*9 1/2"	16ø x L9 1/2", GQX161.1E(Actuator)
ALC202	Fitting Linkage(3RT,4RT)	1 1/4" ø(Product Connection Part) x 3/4" ø(Water Valve Connection Part)
ALG252	Fitting Linkage(5RT)	1 1/2" ø(Product Connection Part) x 1" ø(Water Valve Connection Part)

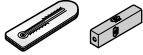
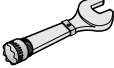
Installation Tools

Figure	Name	Figure	Name
	Screw driver		Ohmmeter
	Electric drill		Ammeter
	Spanner		Thermometer, Horizontal meter
	Torque wrench		
	Tefron Tape		

14. Installation

14.1 Space needed for installation

- For independent installation
- * Basic installation space
- Minimum space as shown in the following figure is needed depending on the piping connection type of the product for easy installation and checking.
- If the location does not comply with this installation diagram condition, please consult with the specialized installation center.

[Unit: inch(mm)]

Pipe connection	A	B
Left pipe	19.7(500)	5.9(150)
Right pipe	5.9(150)	19.7(500)

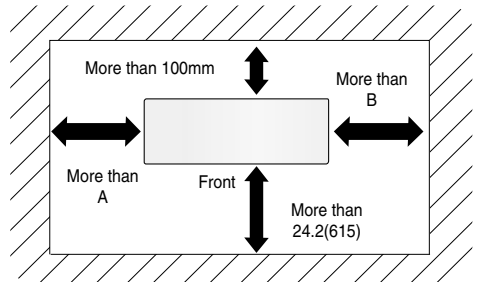

14.2 Moving method and product weight

- Because this product is a heavy object, always use a forklift for transportation and moving.

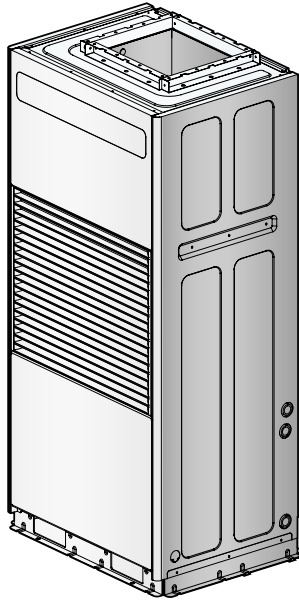

⚠ WARNING

- Be careful of the following when transporting the product.
- Have more than 2 people transport the product if the weight of the product is 20Kg or more.
- PP band is for packing the product. Do not use it for transporting the product.
- Do not touch the heat exchanger fins with bare hands. You can cut your hand.
- Cut the plastic (vinyl) bag used for packaging into small pieces so that children cannot play with it. If not, children can be suffocated while covered in the bag.
- When transporting the product with the forklift, make sure the product does not fall off.

14.3 Basic floor construction

1. Do the basic flooring construction so that the weight of the product can be adequately supported with concrete or similar material considering the product height.
The dimension of the basic construction should be 34" x 26" x 4"(W870 x D660 x H100) or above.
At this time, maintain the level so that the product is not tilted.
If the product is tilted, it can cause performance deterioration and noise.
 2. To reduce the vibration transmission, install the floor anti-vibration pad between the basic flooring and the product.
- ※ Recommended depth of anti-vibration pad: Min 0.8" (20mm)

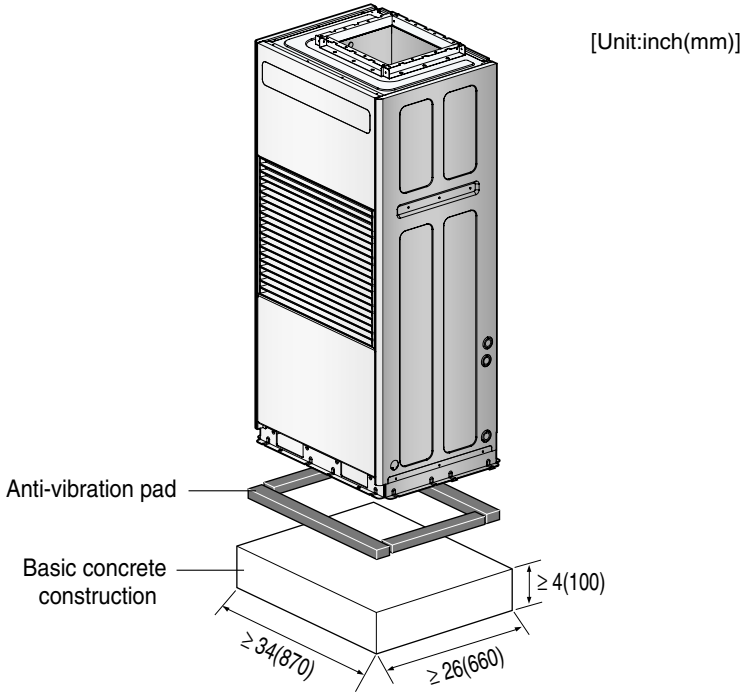

WARNING

- Install the product where the weight of the outdoor unit can be sufficiently supported.
If the unit is installed at a location where the supporting strength is insufficient, the outdoor unit can fall to injury somebody.
- Install the outdoor unit so that it does not fall even with strong wind and earthquake.
If there is a defect in the installed condition, the indoor unit can fall over to injury somebody.
- When creating the base supporter, pay special attention to the supported strength of the floor surface and path of the pipe and wire.

CAUTION

- You must remove the wooden support board (MDF) and packing sheet from the base pan of the outdoor unit before fixing the anchor bolt of the indoor unit.
The fixated condition of the outdoor unit can be unstable and could disable normal operations.

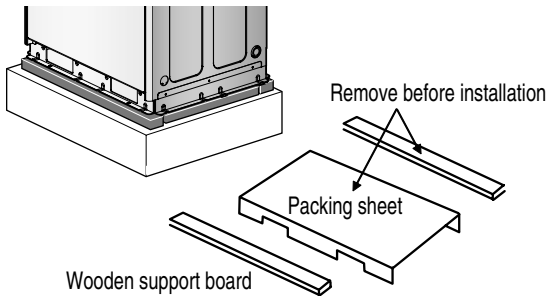

14.4 Heat source water management

- The temperature of the supplied heat source water must be maintained between 59 and 104°F. If not, it can cause problems to the product.
- The flux of the supplied heat source water must be controlled appropriately. If not, it can cause abnormal noise, pipe vibration, pipe contraction or expansion depending on the temperature. For the size of the pipe for heat source water, use the same diameter or above of the connecting pipe.
- Refer to the following table for pipe diameter and flux of the heat source water. The higher the flux, the higher the noise and correction due to the increased speed and higher the inflowing air bubbles.

[Unit:inch(mm)]

Diameter	Flux range(m/s)
≥ 4.9(125)	2.1~2.7
2~3.9(50~100)	1.2~2.1
1(25)	0.6~1.2

- Pay special attention to water quality management. If not, it can cause corrosion to the pipe of the heat source water and cause problems to the product.(Refer to Heat source water quality management table.)
- Since the water temperature higher than 104°F can cause corrosion, it is good to add anti-corrosive agent.
- Install the pipe valve, gauge and sensor where it is easy to maintain and repair. Install the heat source water pipe valve at a low location where it can be drained if necessary.
- Be careful not to let air get in the pipe. Air makes the flux of the heat source water unstable during circulation and reduces the pump efficiency and cause vibration to the heat source water pipe. Therefore, install an air purge (Air discharger) at appropriate locations where air is expected to be generated
- Adopt the following methods to prevent the pipe from freezing. If not, there is a danger of the pipe freezing during the winter.
 - When the temperature drops circulate the water with the pump before it freezes
 - Operate the boiler to maintain room temperature
 - When the unit is not operated for a long period of time during the winter, drain the water of the cooling tower
 - Use the anti-freeze agent
 - Refer to the following table for the minimum amount of the anti-freeze agent to add corresponding to the freezing temperature

Type of anti-freeze agent	Minimum temperature to prevent freezing(°F)					
	32	23	14	5	-4	-13
Ethylene glycol (%)	0	12	20	30	-	-
Propylene glycol (%)	0	17	25	33	-	-
Methanol(%)	0	6	12	16	24	30

* Adding the anti-freeze agent can increase the pressure drop of the heat source water system and reduce the product performance.

- You must use the closed type cooling tower. (You cannot use the open type.)

14.5 Heat source water quality management table

Water with a lot of alien particles can cause corrosion or create scales in the condenser and pipe to affect the performance and life of the product. Use coolant water in accordance with [Environment standard of Enforcement Decree of the Framework Act on Environmental Policy].

When using water other than tap water for the supplementary water in the cooling tower, you must do a water quality test.

- The water quality management must be done for the closed water cooling type heat source water in accordance with the following table.
- TDS (Total Dissolved Solids) among the water quality properties during the summer must be managed to maximum of 1000mg/L and less.

Item	Unit	Coolant criteria
PH	(25°C)	6.0 ~ 8.0
Conduction rate (25°C)	(A μ V/cm)	200 or less
Chlorine ion	(ppm)	50 or less
Sulfuric acid ion	(ppm)	50 or less
Iron	(ppm)	0.3 or less
M alkalinity	(ppm)	50 or less
Total hardness	(ppm)	50 or less
Sulfur ion	(ppm)	Must not be detected
Ammonium ion	(ppm)	Must not be detected
Silica	(ppm)	30 or less
Acetic acid ion	(ppm)	Not regulated

If the water quality of the heat source water is not managed in accordance with the above table, it can deteriorate the air conditioner performance and cause serious problems to the product.

14.6 Heat source water pipe installation

- The recommended internal water pressure for the heat source water system of this product is 1.96MPa.
- Execute the piping construction so that water drops are not formed on the outer side because it is installed indoors.
- For the drain pipe size (1), use the same size as or larger than the pipe connecting to the product.
- Install an air purge (air discharger) in the middle of the pipe and make sure air is not generated.
- After installing the heat source water drain pipe (2), check whether the heat source water is flowing smoothly.
- You must install a strainer (16-20 mesh) at the heat source water inlet pipe.
(When sand, trash, pieces of rust etc. are mixed into the water system, it can corrode the metallic material or clog the heat exchanger to cause a problem.)
- In case of danger of freezing, always treat the pipe to prevent from freezing.

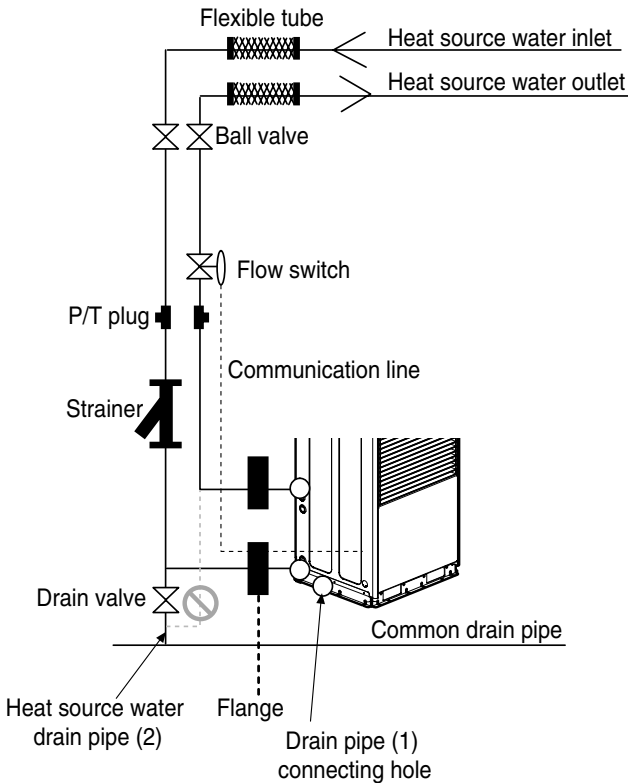

CAUTION

Do not connect the drain outlet to the heat source water outlet.
(It can cause problems to the product.)

14.7 Heat source water pipe connection

- For the heat source water pipe (3) size, use the same size as or larger than the pipe connecting to the product.
- In case of danger of dew condensation, you must install the lagging material at the heat source water outlet pipe.
(Use polyethylene material with the thickness of 20mm for the lagging material.)
- For the connection between the heat source water pipe and the socket, firmly tighten the connection based on the following table.

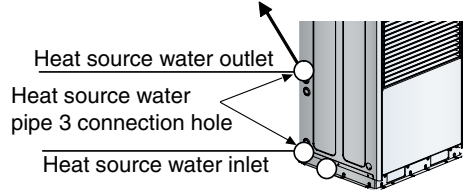

Pipe thickness		Conduction rate		Tensile stress		Bending momentum		Torque	
mm	inch	(kN)	(kgf)	(kN)	(kgf)	(N.m)	(kgf.m)	(Nm)	(kgf.m)
12.7	1/2	3.5	350	2.5	250	20	2	35	3.5
19.05	3/4	12	1200	2.5	250	20	2	115	11.5
25.4	1	11.2	1120	4	400	45	4.5	155	15.5
31.8	1 1/4	14.5	1450	6.5	650	87.5	8.75	265	26.5

14.8 Pipe connection order

1) Separate the cap of the coolant connection part.

2) After taking the rubber cap off the product, insert the connecting pipe.

3) With the rubber cap covered on the pipe, execute the pipe connecting work.

4) Reinsert the rubber cap to the product to finish the work.

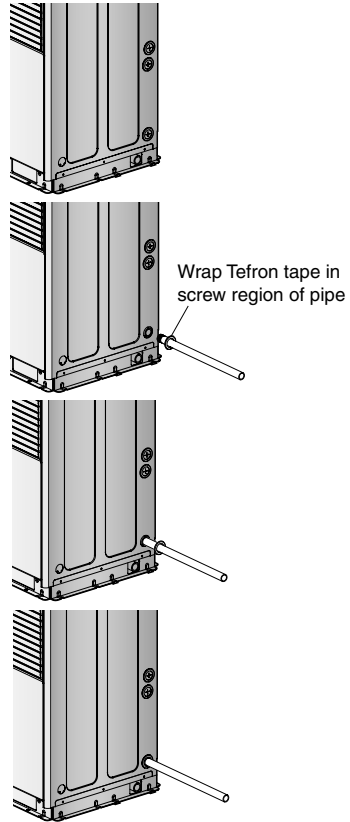

14.9 Flow switch work

- For this product, you must install the flow switch in the unit connection return pipe system. (If you do not install the flow switch, it will display the error information (CH 24) and the product will not be operated.)
- Select the flow switch permitted pressure specification considering the pressure specifications of the heat source water system. (But, you must use the one for AC 250V voltage.)

CAUTION

- If you do not install the flow switch and arbitrarily operate the product, it can cause problems to the product.
- When you operate the product when the heat source water does not flow smoothly, it can cause problems including damage to the heat exchanger etc.

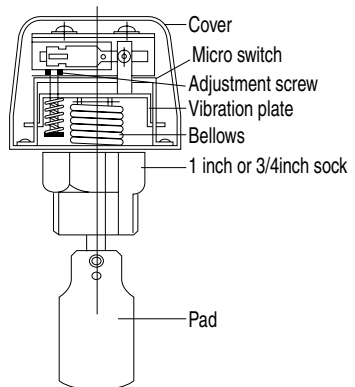

14.10 Flow switch installation

- Install the flow switch after checking direction of the heat source water flow of the heat source water outlet of the product. (Pic 1.)
- Connect the flow switch to the communication terminal (No. 2 and 3) of the outdoor unit control box of this product. (Pic 2~3)
(Open the flow switch cover and connect after checking the wiring diagram. The connecting method may be slightly different by the flow switch manufacturer.)
- The permitted flus range for this product is 32.5~97.5 lpm



Pic. 1

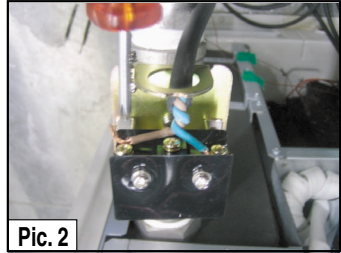

Pic. 2

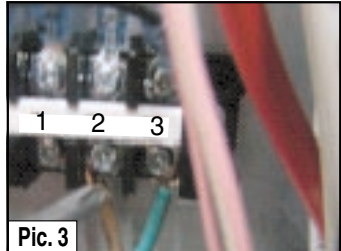

Pic. 3

Wiring diagram

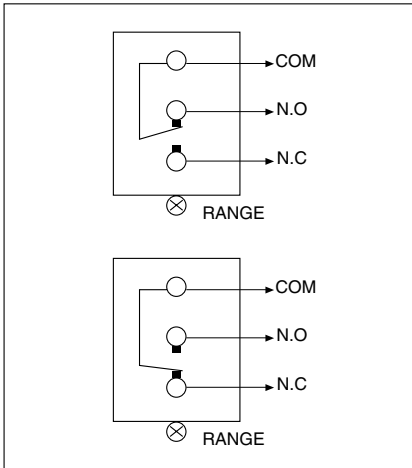

CAUTION

Do not adjust the flux detection adjustment screw.
When the product operates within the outside of the permitted flux range with the contact points joined, it can deteriorate the performance and cause problems.

14.11 Coolant piping connection

- The internal water pressure of the coolant piping system of the air conditioner is 20kg/cm².
- For the pipe size of the coolant, use the same size as the air condition connecting pipe or wider. (When using the cooling tower, use the pipe size of the cooling tower side.)
- The internal water pressure of the coolant piping system of the air conditioner is 20kg/cm².
- For the pipe size of the coolant, use the same size as the air condition connecting pipe or wider. (When using the cooling tower, use the pipe size of the cooling tower side.)
- Install an air drawer within the pipe and make sure cavitations don't occur.
- The inlet/outlet pipe of the coolant must be insulated with lagging material to prevent from freezing and icing.
- Install the valve for chemical cleaning and heat exchanger cleaning port at a location where they are easy to operate.
- Use KS standard product for the valves.

 **CAUTION**

- You must install a strainer at the coolant inlet pipe. (Use 16-20 mesh for the strainer.)
If not, it can cause problems to the product.
- When connecting the coolant pipes, always wrap Teflon tape on the screwed part. If not, it can cause leakage to cause an accident.

14.12 Condensed water piping connection

- Install the drain pipe to be as short as possible and the inclination should be at a minimum of 1/100.
- For the size of the drain pipe, use the same size as the air condition connecting pipe or wider.
- For the drain pipe and connecting socket, you must cover them with lagging material so that icing is not formed. Lagging material thickness: 2"(50mm)
- By using the drain trap as shown in the following diagram, make sure the drain pressure reduction is not applied.

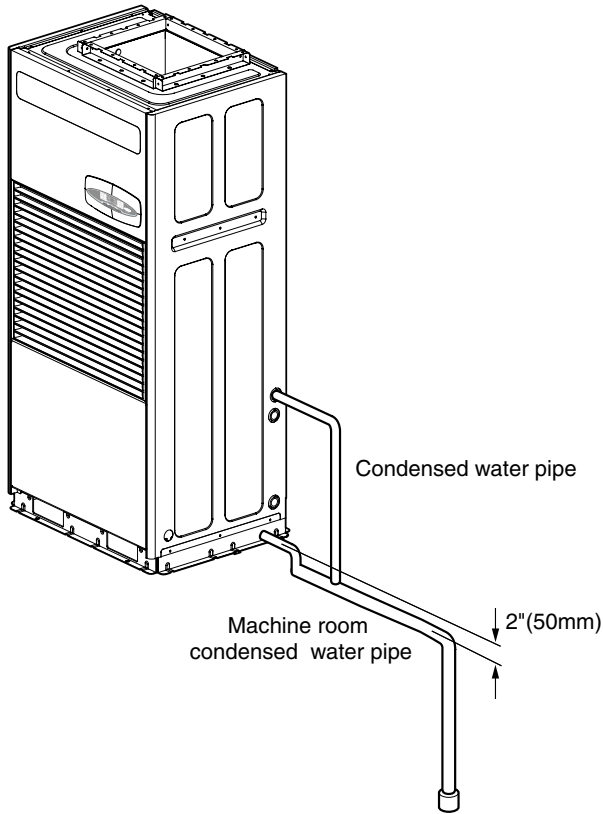

CAUTION

- Make sure you do not mistakenly mix the condensed water outlet and the coolant outlet. It can cause a problem or an accident.
- When connecting the condensed water pipe, always wrap Teflon tape on the screwed part. If not, it can cause a leakage to cause an accident.

14.13 Duct connection

1) By using the flexible duct (duct connecting part), connect noise chamber connected to the main duct within the building and the air discharge part on top of the air conditioner so that air does not leak. (If you do not use the flexible duct, it can cause vibration and noise.)

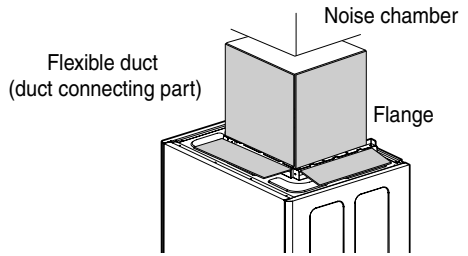

2) After inserting the flexible duct between the flange and the discharge part, tighten the flange using the bolt.

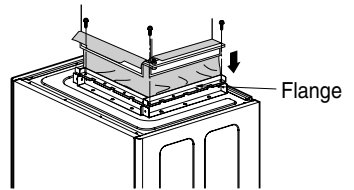

3) Wrap lagging material on the external side of the flexible duct (duct connecting part) to finish with finishing tape. (It maintains the air conditioner performance.)

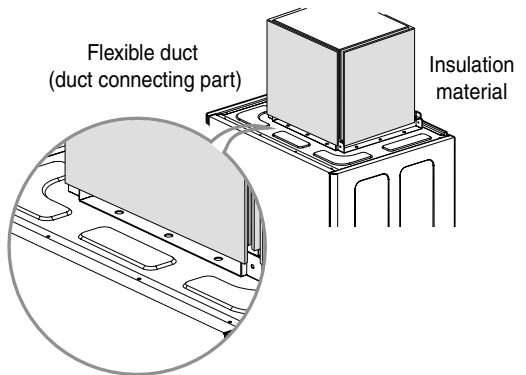

14.14 Main power wire connection

- 1) First, separate the panel on the front bottom side of the product.
Connect the power according to the electric connection diagram attached on the control box cover.
(Check whether the terminal part is connected properly.)
By using the ring type terminal, connect the main power wire to the main power terminal block and fixate the cord clip.
- 2) Check whether the main power is grounded. Do not connect the grounding wire to the gas pipe, water pipe, lightning rod or telephone grounding wire together.

⚠ WARNING

- If the product is not grounded properly, there is a danger of electric shock.
- Grounding must be done by a qualified personnel.

- 3) The main power connection, circuit breaker and grounding wire assembly construction must be done in accordance with the "Electric Facility Engineering Standard" and "Interior Wire Regulations".

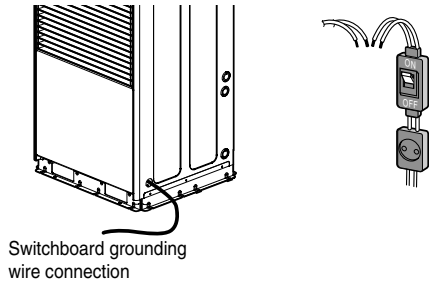

14.15 Main power connection and facility capacity

- Consider the surrounding condition (surrounding temperature, direct sunlight, rain drops etc.) when working on the connection.
- The thickness of the wire is the minimum thickness for metal conduction wire. Use a thicker wire of one grade above considering the voltage drop.
- When special connection is necessary, comply with the regulation of the applicable region.
- Use standard product for power wires.

 **WARNING**

- You must always use the regulated wires so that the connecting part of the terminal does not come off by external force. Unless the connecting part is firmly fixated, it can cause a heating to cause a fire.
- Always use an appropriate over current protection switch. Keep in mind that over-current that occurs includes the AC current for some time.
- Some installation locations require a grounding leakage breaker to be installed. If a leakage breaker is not installed, it can cause an electric shock.
- Use only the circuit breaker and fuse of accurate capacity. If you use a fuse, wire or copper line of excessively large capacity, it can cause a malfunction or a fire.

Connect the cable

Connect the cable to the unit by connecting the wires to the terminals on the control board individually according to the unit connection.

The earth wire should be longer than the common wires.

The circuit diagram is not subject to change without notice.

When installing, refer to the wiring diagram behind the panel front of Unit.



CAUTION:

- The diagram is not subject to change without notice.
- Be sure to connect wires according to the wiring diagram.
- Connect the wires firmly, so that not to be pulled out easily.
- Connect the wires according to color codes by referring the wiring diagram.



CAUTION: The power cord connected to the unit should be complied with the following specifications.

Model	Min. Thickness (inch ²)		Circuit breaker (NFB)	Leak current circuit breaker (ELB)
	Main/Earth	AWG		
AKWW0603UA0	0.020/0.020	6	45A	45A 100mA 0.1sec ↓
AKWW0483UA0	0.013/0.013	8	35A	35A 100mA 0.1sec ↓
AKWW0363UA0	0.008/0.008	10	30A	30A 100mA 0.1sec ↓

※ Allowable temperature to the wire rated at least 90C°



RECOMMEND: Provide a circuit breaker between power source and the unit as shown below.

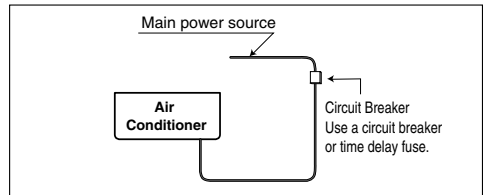

RECOMMEND: The power cord connected to the unit should be complied with the following specifications (ETL recognized and CSA certified).

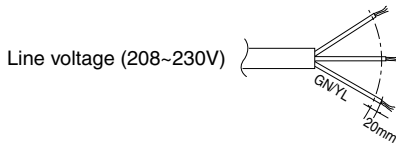

The power connecting cable connected to the indoor and outdoor unit should be complied with the following specifications (ETL recognized and CSA certified).

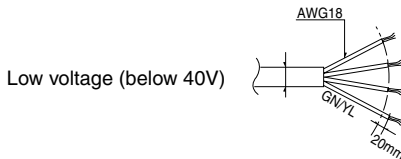

RECOMMEND: When using the separate wire as the power cord, please fix the separate wire into the control box panel by using tie wrap as the fixture.

14.16 Central controller communication wire connection

1) First, separate the panel on the front bottom side of the product.

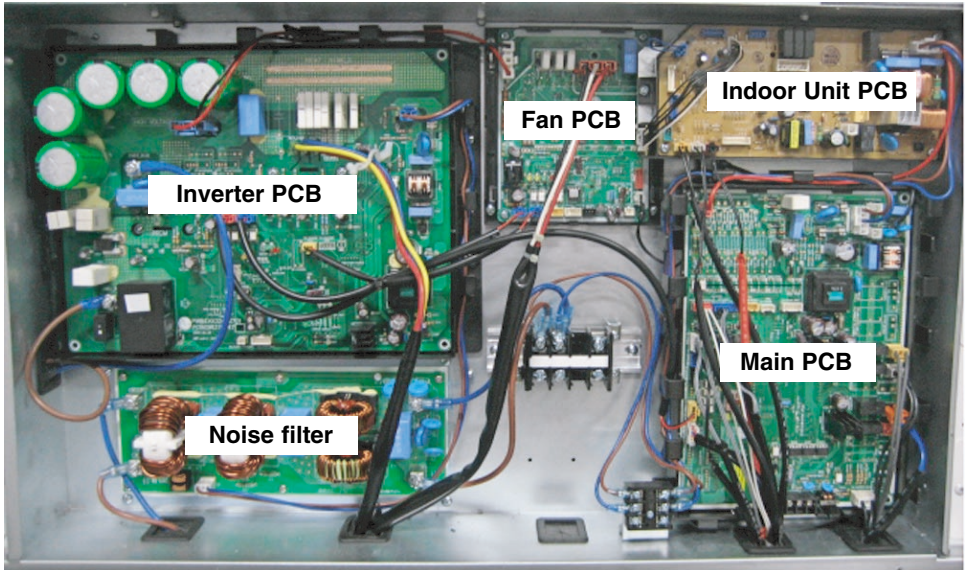

2) Connect the central controller communication wire to the board on the bottom right side of the control box. (Check whether the terminal part is connected properly.) You must fixate the communication wire using the cord clip.

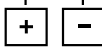
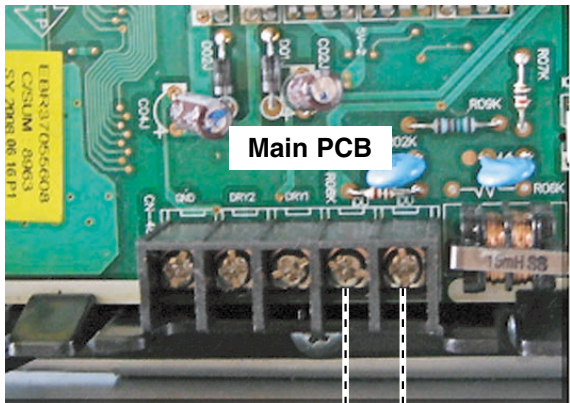

Master Controller

14.17 Communication wire and power wire

1) Communication wire (Between Unit and VAV Master controller)

- Type: Shield wire
- Insulation material: PVC
- Maximum communication distance: 33'(10m) or below.
- Diameter: 0.002 inch²(1.25mm²)
- Maximum permitted temperature: 60°C

2) Remote controller wire

- Type: 3-Line cable

3) Clearance distance between communication wire and power wire

(When the power wire and the communications wire are connected in parallel, they create a statically electric and electronic system defect that can cause a system malfunction. Ensure 50mm or more of clearance distance between the power wire of the indoor unit and communication wire.)

[Unit:inch(mm)]

	Power wire current capacity	Clearance distance
100V or more	10A	1.2(300)
	50A	2.0(500)
	100A	3.9(1000)
	100A more	5.9(1500)

Note:

1) This is the value assuming the parallel cable distance runs up to 328'(100m). When it is over 100m, you can recalculate the value by the added distance in proportional increments.

2) If the distortion in power wave shape continues even after maintaining the clearance distance, increase the clearance distance.

- When putting all wires into the transmission wire or when tying all the wires to one, you must consider the following.
 - You cannot put the power wire and the communications wire in the same transmission wires.
 - You cannot tie both the power wire and the communication wire together.

14.18 Leakage checking method

- When reinstalling the product, the service that occurs from not using designated installation dealer or the service center will be processed as paid service.

1) Pull out the suction grill.

- When you pull the top part of the suction grill lightly forward, the suction grill can be opened. Loosen the connecting hook attached on the suction grill. Then the suction grill will be separated.

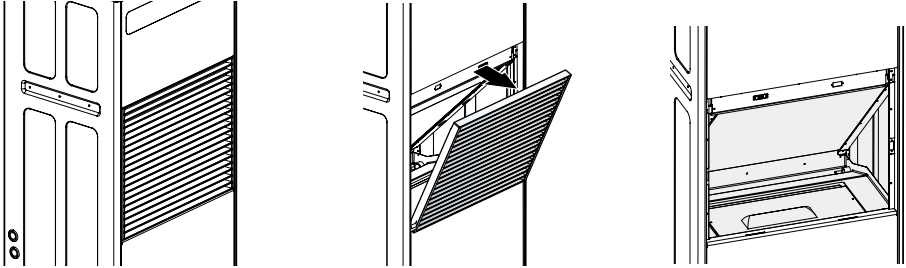

2) After pouring the water in the inner water collector of the drain pan and check whether water is leaking.

- Pour water in the drain hole to be fully covered.

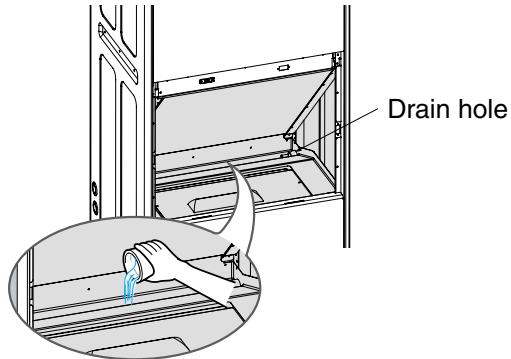

3) Check whether water is drained through the drain pipe.

If water does not come out, you must recheck the installation condition.

- When it is impossible to check the drain pipe, judge by whether the water in the inner water collector is being reduced.

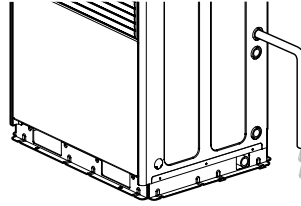

4) Open the valve of the pipe connected to the coolant inlet/outlet to circulate the water.

(Open the outlet drain pipe valve first.)

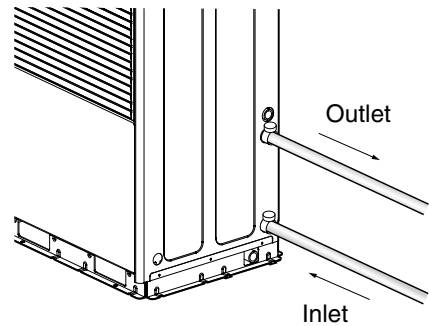

5) Check whether water is leaking in each connecting part.

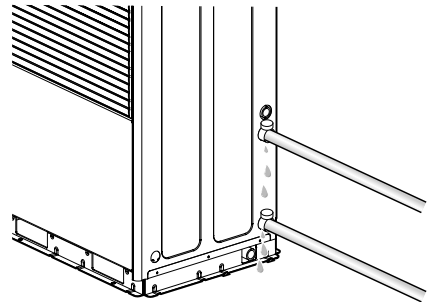

6) In case of coolant leakage

- (1) Tighten the connecting part of the coolant drain to stop the leakage.
- (2) Recheck for leakage in the connecting part or parts where leakage can occur.
- (3) If there is no leakage, proceed to the next work phase.

14.19 Air leakage check

1) After the air conditioner connection is completed, run the unit in fan condition.

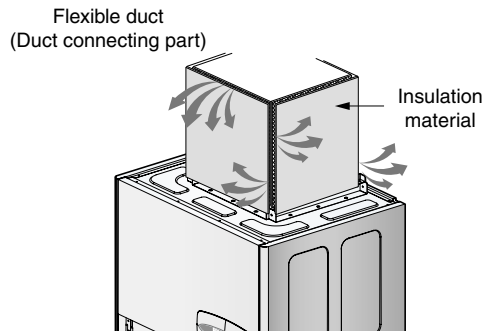

2) You must check for air leakage in the flexible duct and duct connecting part.

3) In case of air leakage

- (1) Tighten the connecting part of the duct to stop the leakage.
- (2) Recheck for leakage in the connecting part or parts where leakage can occur.
- (3) If there is no leakage, proceed to the next work phase.

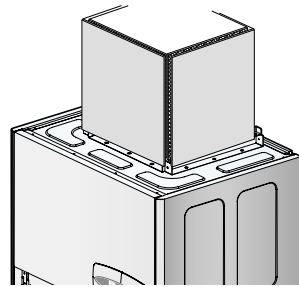

14.20 Checkpoints after installation

You must read the using method through the manual to the consumer and check the following points after installing the product.

* (Check the square box)

- Is an exclusive power circuit formed?

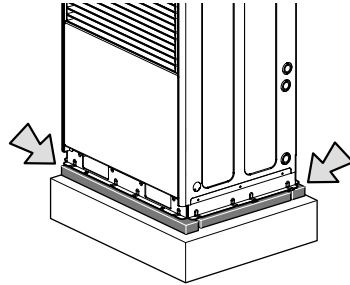

- Is the installation strength adequate?

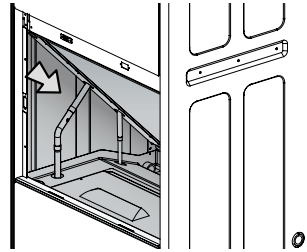

- Isn't there any leakage in the pipe?

14.21 Air leakage check

- Is the main power wires properly inserted and fixated?
Check with the switchboard power turned off.

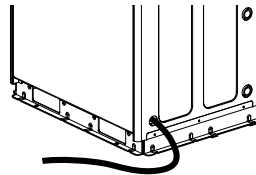

- Is the grounding wire properly connected?
Is the power cord properly grounded?

- Isn't there any leakage in the coolant pipe?
Isn't there any problem in the coolant circulation?

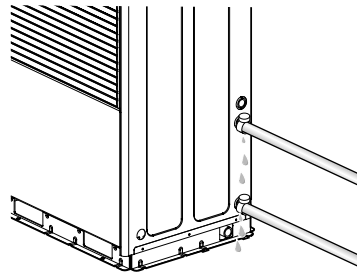

- You must check whether the air filter is properly installed and whether it isn't badly contaminated with dust.
If the air filter is not properly installed, it cannot filter the air flowing into indoors and can cause problems to the air conditioner due to the contamination.

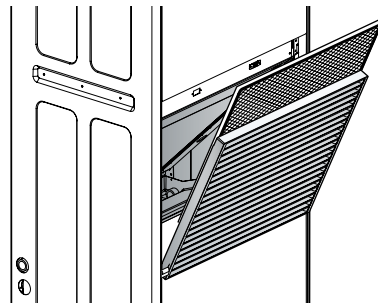

14.22 Test operation

You must read the using method through the manual to the consumer and check the following points after installing the product.

* (Check the square box)

- Isn't there any problem during central control operation?

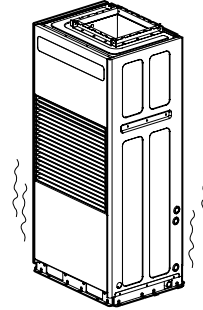

- Isn't there any noise?
 - The shape of the product may differ slightly depending on the model.

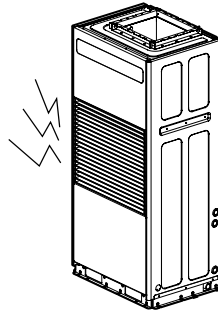

- Is the air conditioning performance normal?
 - Check the following details after operating the product for 15-20 minutes.
 - 1) Measure the temperature of the inlet and outlet.
 - 2) Check whether the temperature difference between the inlet and outlet is over 8°C.

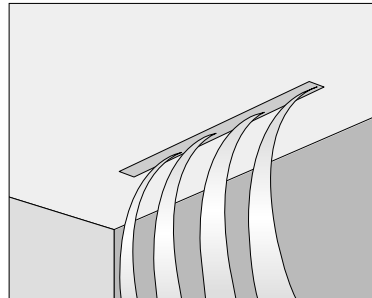

Installation

- Is the product well drained?
 - Isn't there any leakage in the connecting part of the condensed water pipe?
- The shape of the product may differ slightly depending on the model.

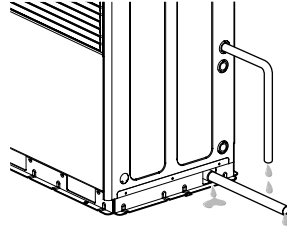

14.23 Troubleshooting during test operation

The following is the key part defects

Parts	Symptom	Cause	Check and resolution
Compressor	Does not operate	Motor insulation broken	Measure the resistance between the compressor power terminal and the chassis.
		Strainer clogged	Replace the strainer.
		Insufficient lubrication fluid	Open the drain cork and check the lubrication fluid.
	Stops during operation	Motor insulation broken	Measure the resistance between the compressor power terminal and the chassis.
	Generates loud noise during operation	Cross connection	Check the compressor power connection.
External electronic expansion valve	No operation sound even after turning the power on	Coil defect	Check the resistance between the terminals. EEV checking method
	Low pressure error or discharge error	Electronic expansion valve clogged	Discharge temperature error

If there is a problem in the system, the error code is displayed in the display window of the indoor unit. Refer to the repair manual of service technical manual for the problem check and repair

14.24 Precaution when handing over to customer

First explain the user summary attached on the air conditioner to the customer and explain the user manual so that it is easy to understand. (Parts directly relevant for customer safety, such as precautions, must be explained.)

Before leaving the site, check for gas or coolant water leakage one more time and provide the product warranty (completion confirmation, installer business card). Clean the surrounding environment and wipe any stains that could have resulted from the installation work.

