



Internal Use Only

<http://biz.lgservice.com>

Multi Air Conditioner

SVC MANUAL(Exploded View)

MODEL : AMNW09GDER1(LMAN095HVT)
AMNW12GDER1(LMAN125HVT)

CAUTION

Before Servicing the unit, read the safety precautions in Standard SVC manual.
Only for authorized service personnel.

1. Specification

Indoor unit type			ART COOL Mirror	
Model			AMNW09GDER1[LMAN095HVT]	AMNW12GDER1[LMAN125HVT]
Power Supply		Ø / V / Hz	1/ 208~230/ 60	1/ 208~230/ 60
Capacity(*)		Btu/h class	9,000	12,000
Current	Running Current	A	0.15	0.15
Fan	Motor Type		BLDC	BLDC
	Fan Type		Cross Flow Fan	Cross Flow Fan
	Motor Output(W) x No. of Unit		7.8 x 1	7.8 x 1
	Air Flow Rate (H / M / L)	CMM	8.0/7.0/5.0	10.0/8.0/6.0
		CFM	282/247/177	353/282/212
	External Static Pressure		mmAq	-
	Capacitor		µF / Vac	-
	Drive		Direct Drive	Direct Drive
Coil	Row x Column x FPI		2R x 15C x 18	2R x 15C x 18
Dimensions (W x H x D)	Body	mm(inch)	915 x 282 x 165 (36 x 11 3/32 x 6 1/2)	915 x 282 x 165 (36 x 11 3/32 x 6 1/2)
	Decorative Panel	mm(inch)	-	-
Net Weight	Body	kg (lbs)	9.5(20.9)	9.5(20.9)
	Decorative Panel	kg (lbs)	-	-
Air Filter			Long life filter	Long life filter
Sound Level (H / M / L)		dB(A)+3	31/26/22	35/28/24
Piping	Liquid	mm (inch)	6.35 (1/4)	6.35 (1/4)
Connections	Gas	mm (inch)	9.52 (3/8)	9.52 (3/8)
	Drain(OD/ID)	mm(inch)	20/16 (0.787/0.630)	20/16 (0.787/0.630)
Dehumidification Rate		l/h	1.2	1.5
Safety Devices			Fuse, Thermal Protector for Fan Motor	Fuse, Thermal Protector for Fan Motor
Temperature Sensor			Thermistor	Thermistor
Refrigerant			R410A	R410A
Refrigerant Control			EEV(in Outdoor unit)	EEV(in Outdoor unit)
Transmission Interunit Cable		No. x AWG	4X18(Including Earth)	4X18(Including Earth)

Note:

1. Capacities are based on the following conditions:

- Cooling: - Indoor Temperature 26.7°C(80°F) DB/19.4°C(67°F)
- Outdoor Temperature 35°C(95°F) DB/23.9°C(75°F)
- Heating: - Indoor Temperature 21.1°C(70°F) DB/15.6°C(60°F) WB
- Outdoor Temperature 8.3°C(47°F) DB/6.1°C(43°F) WB
- Piping Length - Interconnecting Piping Length 7.5m(24.6 ft.)
- Level Difference of Zero

- 2. Wiring cable size must comply with the applicable local and national code.
- 3. The specification may be subject to change without prior notice for purpose of improvement.
- 4. For more Capacity(*), refer to the combination table

Conversion Formula
kW = Btu/h class X 0.0002931
cfm = CMM x 35.3

2. List of Functions

Category	Function	AMNW09GDER1[LMAN095HVT]	AMNW12GDER1[LMAN125HVT]
Air flow	Air supply outlet	1	1
	Airflow direction control(left & right)	Auto	Auto
	Airflow direction control(up & down)	Auto	Auto
	Auto swing(left & right)	O	O
	Auto swing(up & down)	X	X
	Airflow steps(fan / cool / heat)	3 / 4 / 3	3 / 4 / 3
	Chaos swing	O	O
	Chaos wind(auto wind)	O	O
	Jet cool(Power wind)	O	O
Air purifying	Swirl wind	X	X
	Deodorizing filter	O	O
	Plasma air purifier	O	O
Installation	Prefilter(washable / anti-fungus)	O	O
	Drain pump	-	-
	E.S.P. control	-	-
	Electric heater(operation)	-	-
Reliability	High ceiling operation	-	-
	Hot start	O	O
	Self diagnosis	O	O
	Soft dry operation	O	O
Convenience	Auto changeover	X	X
	Auto cleaning	O	O
	Auto operation(artificial intelligence)	O	O
	Auto restart operation	O	O
	Child lock	-	-
	Energy-Saving Cooling Mode	X	X
	Forced operation	O	O
	Group control	-	-
	Sleep mode	O	O
	Timer(on/off)	O	O
Individual control	Timer(weekly)	-	-
	Two thermistor control	-	-
	Wide wired remote controller	O (PQRCUSA0)	O (PQRCUSA0)
	Deluxe wired remote controller	-	-
	Simple wired remote controller	O (PQRCUCA0)	O (PQRCUCA0)
	Simple wired remote controller(for hotel use)	-	-
	Wireless remote controller(simple)	X	X
	Wireless LCD remote control	X	X
CAC network function	Wireless LCD remote control(Ez)	O	O
	General central controller (Non LGAP)	X	X
	Dry contact	Accessory (PQDSB)	Accessory (PQDSB)
	Central control(LGAP)	X	X
Special function kit	PDI(power distribution indicator)	X	X
	PI 485	X	X
	CTIE	X	X
Others	Zone control	-	-
	Thermistor	-	-

Note :

O : Applied, X : Not applied, - : No relation

Option: Model name & price are different according to options, and assembled in factory with main unit.

Accessory: Installed at field, ordered and purchased separately by the corresponding model name, supplied with separate package.

3. Piping Diagrams

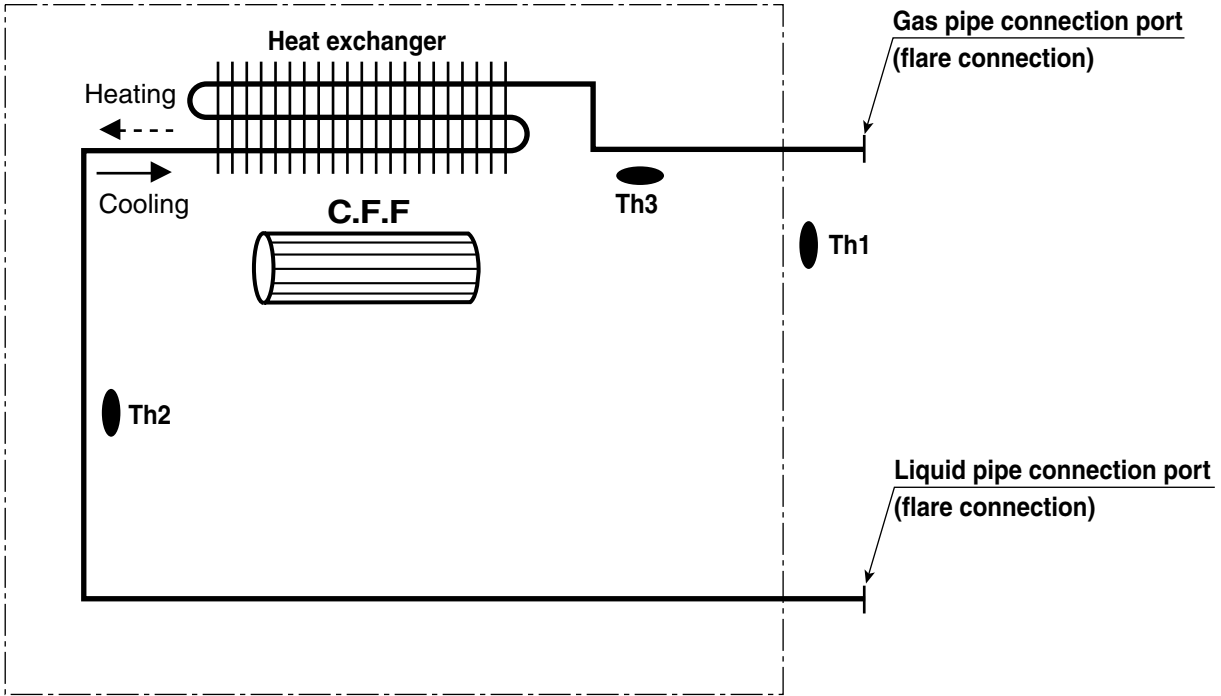

LOC.	Description	PCB Connector
Th1	Thermistor for Inlet air temperature	CN_TH1
Th2	Thermistor for Liquid line temperature	CN_TH1
Th3	Thermistor for Gas line temperature	CN_TH2

4. Wiring Diagrams

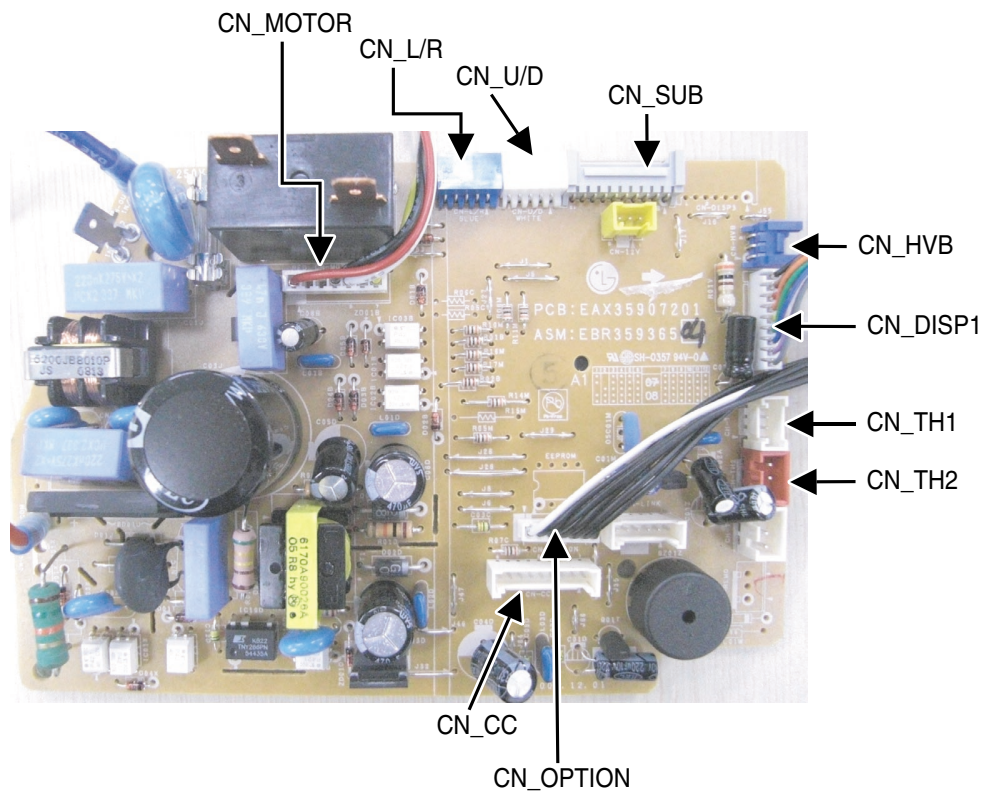
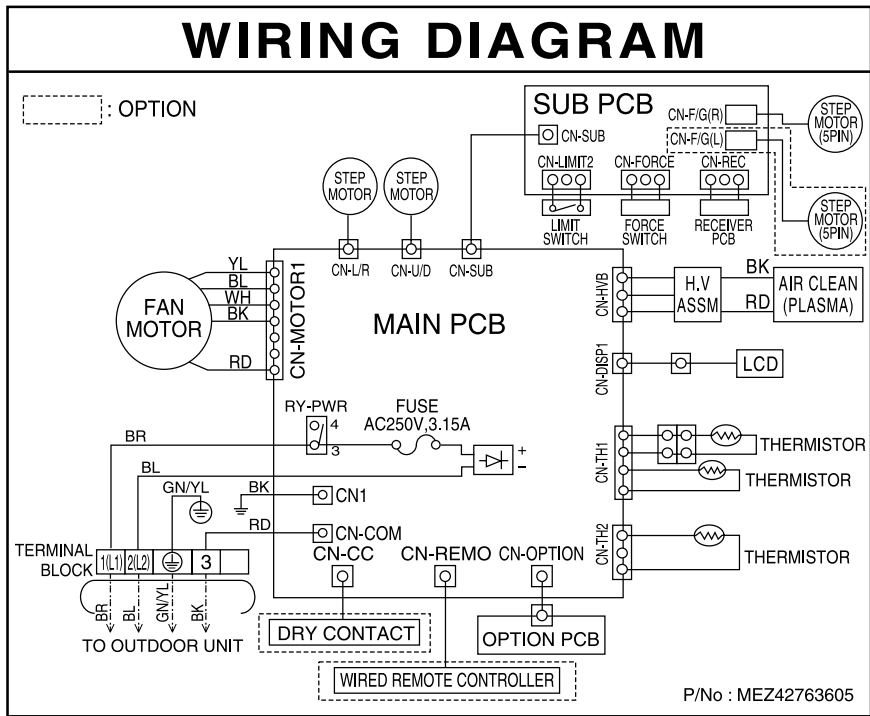

5. Exploded View

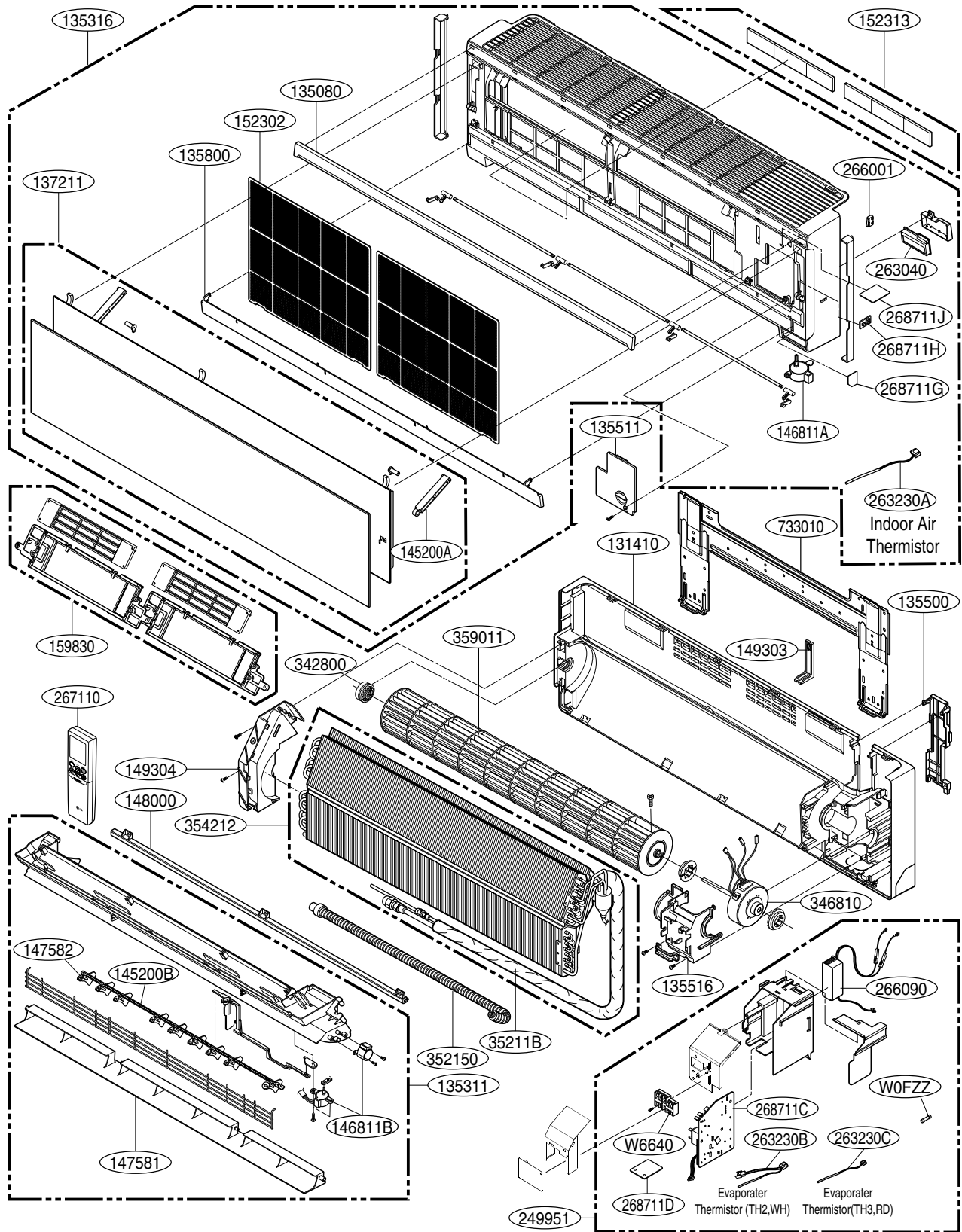

Note) * Please ensure GCSC since the replacement parts may be changed depending upon the buyer's request.
Please check the correct parts in View RPL(Replacement Part List) on GCSC.
(GCSC Website <http://biz.Lgservice.com>.)



P/NO : MFL61777619

AUGUST, 2009