

This Owner's Manual is provided and hosted by [Appliance Factory Parts](#).

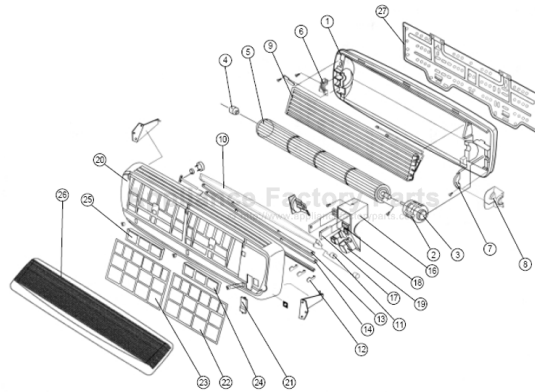

# TURBO AIR TAS-15H Owner's Manual

[Shop genuine replacement parts for TURBO AIR  
TAS-15H](#)



[Find Your TURBO AIR HVAC Parts - Select From 6 Models](#)

----- Manual continues below -----

# 1. SPECIFICATIONS

ITEM			TAS-12H	TAS-15H	TAS-18H	TAS-24H
Function			Cooling & Heating			
Capacity	BTU/H		11,500 / 12,000	14,500 / 15,000	17,500 / 18,000	21,500 / 22,000
SEER			10.0	10.0	10.0	10.0
H.S.P.F			6.8	6.8	6.8	6.8
Dehumidification	L/H		1.5	1.8	2.5	3.0
Electrical Data						
Main Power			AC 208/230V~, 60Hz, 1 Ph			
Running Current	A		5.0/5.4	6.5/6.6	8.0/8.0	10.0/10.3
Watts	W		1,130 / 1,230	1,470 / 1,500	1,800 / 1,780	2,210 / 2,280
Refrigerant			R-22			
Quantity	OZ		38.8 (1100g)	41.62 (1180g)	43.39 (1230g)	64.55 (1830g)
Connection			Flare			
Gas Side	inch		3/8" (9.52mm)	1/2" (12.7mm)	1/2" (12.7mm)	5/8" (15.9mm)
Liquid Side	inch		1/4" (6.35mm)	1/4" (6.35mm)	1/4" (6.35mm)	3/8" (9.52mm)
Compressor			QK173KAB	QJ222KCC	48D185IU1EH	QP325KBB
O.L.P			MRA 98996-12026	MRA 12074-12027	MRA12149-12007	Internal
LRA	A		29	34	43	68
Motor	Indoor		FDA353DWA	FDA353DWB	FDA353DWC	
	Outdoor		YDK-50-6A1	YDK-50-A1	YDK-50-A1	A2929GS010
Capacitor Dual			3/25 $\mu$ F 400VAC	3/35 $\mu$ F 400VAC	3/40 $\mu$ F 400VAC	5/40 $\mu$ F 400VAC
Dimension			Unit conversion : 1 inch = 25.4 mm			
Indoor	W x H x D	mm	815x285x195	1035x322x205	1080x298x200	1080x298x200
	Weight (net)	lb	20.3 (9.2kg)	26.7 (12.1kg)	32.4 (14.7kg)	32.4 (14.7kg)
Outdoor	W x H x D	mm	800x615x320	800x615x320	800x615x320	872x675x325
	Weight (net)	lb	110.3 (50kg)	110.3 (50kg)	110.3 (50kg)	141.1 (64kg)

## \* The Ranges of Temperature And Humidity.

Indoor Temp	Outdoor Temp	Indoor Humidity
65~90°F	70~109°F	Less than 80%
(18~32°C)	(21~43°C)	

## \* Standard Rating Condition

Indoor		Outdoor	
DB	WB	DB	WB
80°F	67°F	94°F	75°F
(26.7°C)	(19.4°C)	(35.0°C)	(23.9°C)

# 2. INSTALLATION

## BASIC ACCESSORIES

This Installation section explains how and where to connect this new air conditioner. Please read make sure all accessories are included as shown below and read manual thoroughly. This Installation section is provided to assist the person knowledgeable in air conditioner installation and should not be installed by anybody who is not thoroughly familiar with this type of installation. Please contact a professional installer if necessary.

### ACCESSORIES SUPPLIED WITH THE UNIT:

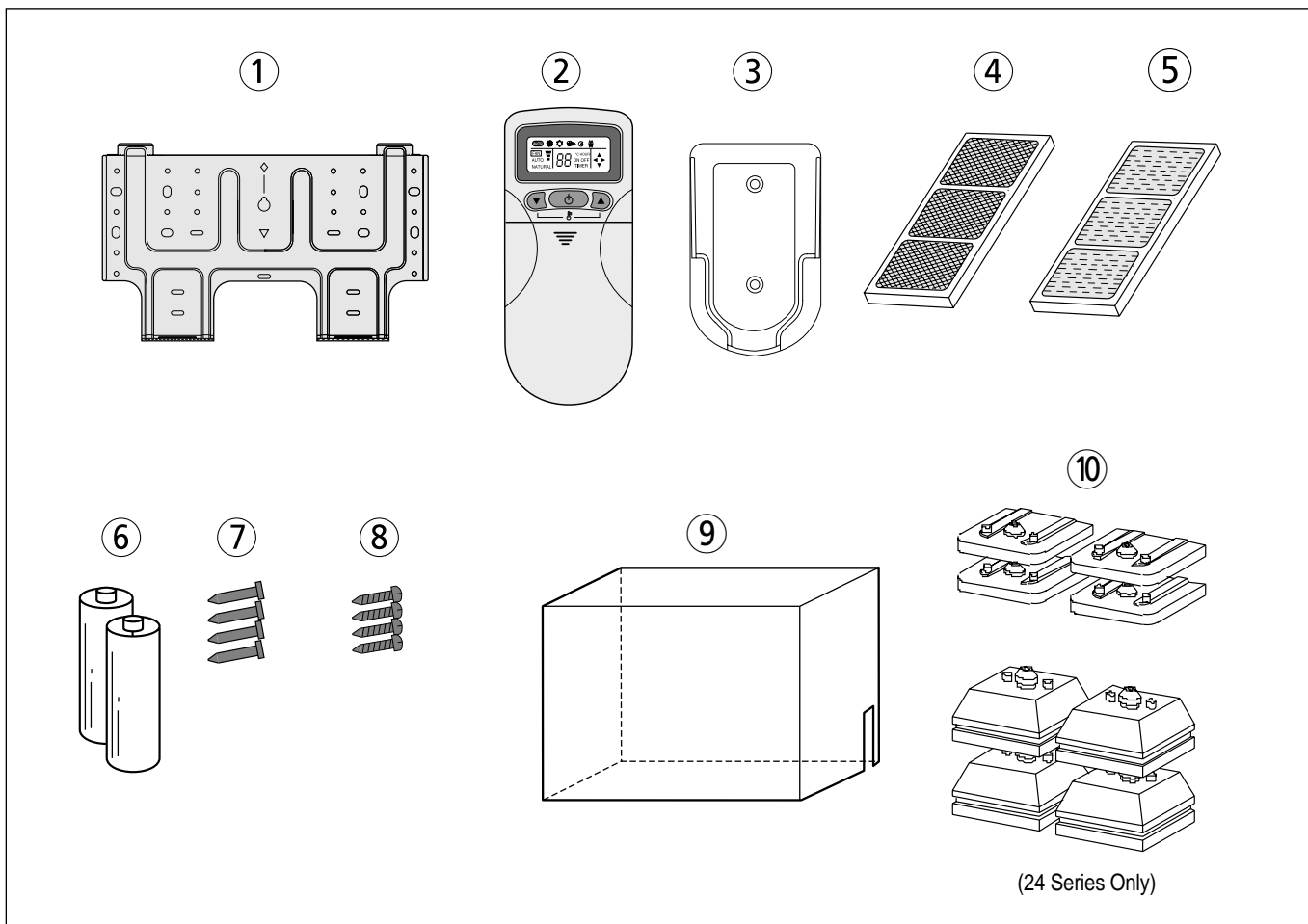

No	Part Name	Q'ty	Remark	No	Part Name	Q'ty	Remark
1	Installation Plate	1		6	Battery	2	
2	Remote Controller	1		7	Nail	4	
3	Remote Holder	1		8	Screw	4	
4	Deodorizing Filter	1		9	Outdoor Cover	1	
5	Electrostatic Filter	1		10	Foot Cushion	4	

## OPTIONAL ACCESSORIES

### ACCESSORIES NOT SUPPLIED WITH THE UNIT:

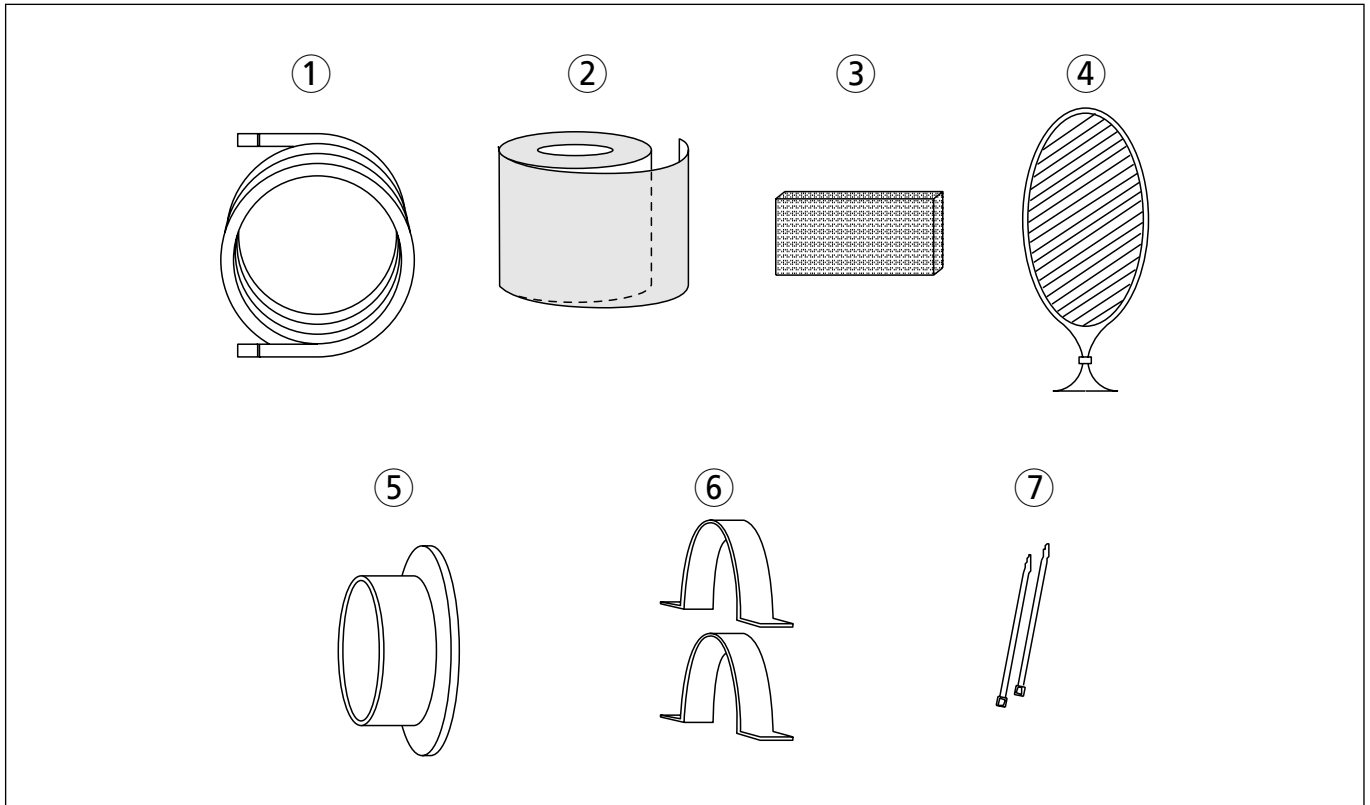

No	Part Name	Q'ty	Description	Remark
1	Drain Hose Extension	1	PVC, 20mm x 2M	
2	Tape Finish	1	PVC, W80mm x 25M	
3	Insulator Plate	1	PE, T8.0	
4	Putty	1	Gray, 80g	
5	Wall Cap	1	HIPS,	
6	Bracket Saddle	2	SCT, T0.8	TAS-24H Only
7	Cable Tie	2	DACT-190A	TAS-24H Only

# INSTRUCTION OF INSTALLATION

Below is an overview for the connection of the Indoor unit to the Outdoor unit.

## OVERVIEW

This appliance must be installed according to national power supply acquirement.

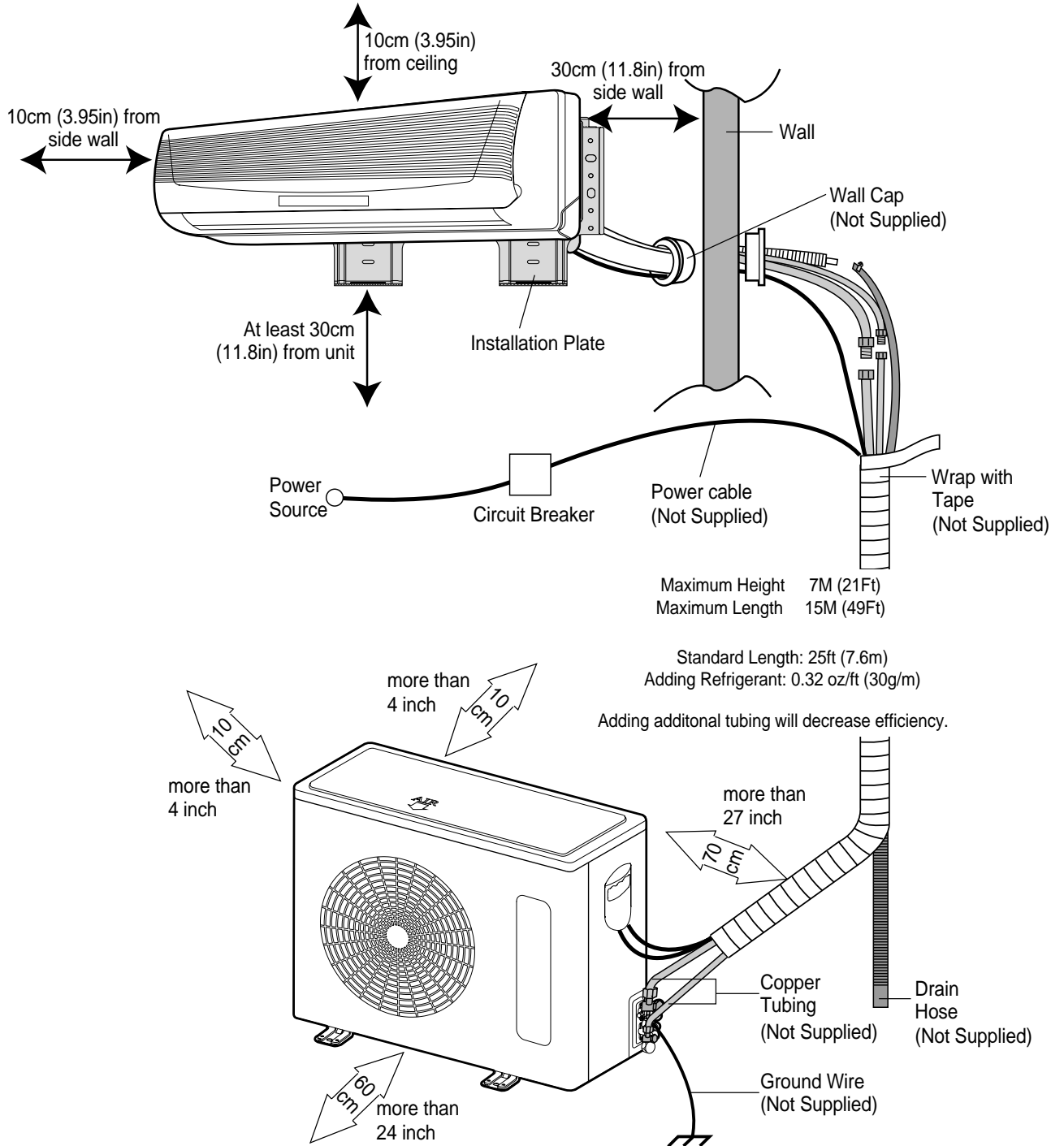

# INSTALLATION

## SELECTING A SITE:

### INDOOR UNIT

- Do not install the unit in an area with direct sunlight, near heat sources (radiator, etc.), or an area where leakage of flammable gas may be expected.
- Select a position in the room, high on the wall, where the whole room can be uniformly cooled.
- Select a location that can hold the weight of the unit and where the copper tubing, drain hose and Indoor to Outdoor Wire have the shortest distance to the Outdoor unit.
- Make sure the Indoor unit is installed at least 10cm (3.95in) away from the top and left side wall and at least 30cm (11.8in) from AC outlet and right side wall.

### OUTDOOR UNIT

- Do not install the unit in an area near heat sources, exhaust fans, or an area where leakage of flammable gas may be expected.
- Do not install the unit in a humid, damp or uneven location.
- Select a location that is well ventilated .
- Leave enough room around the unit for air intake, exhaust and possible maintenance.

## INSTALLING THE INSTALLATION PLATE

To install the wall bracket, follow the procedures below. One hole is required for the tubing and may be either on the left or right side.

1. Determine the type of wall (sheetrock, concrete, etc.) and make sure it is strong enough to hold indoor unit. Select an approximate position for the unit, taking the required distances away from walls/AC outlet into consideration.

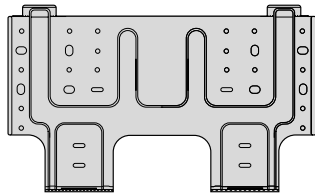

2. Determine if the hole is to be made at the left or right hole location.

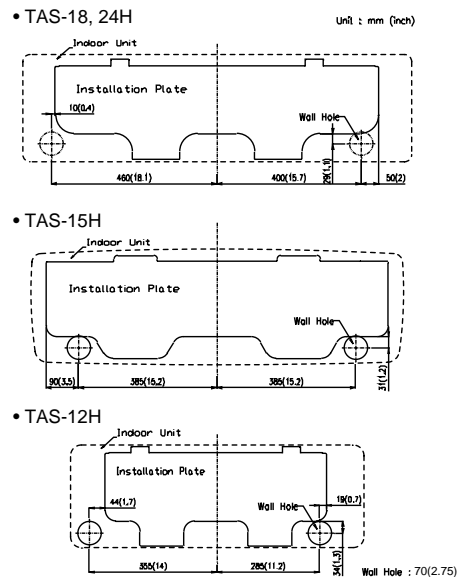

### CAUTION

- Before making hole, make sure there are no studs, pipes, electrical wiring or conduit directly behind the area to be cut.

3. Using drill with hole-cutting attachment or equivalent, cut a hole 70mm (2.75") in diameter. The hole should be made at a slight downward slant to the outdoor side. Measure the thickness from the inside to outside edges and cut a PVC pipe at a slight angle 1/4" shorter than the thickness of the wall and insert pipe in wall.

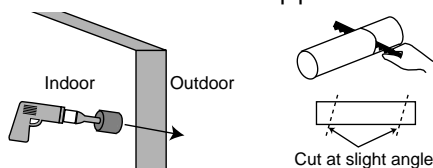

4. For sheetrock, wooden or similar wall, measure down from the ceiling using a level or tape measure and attach the wall bracket to the wall using 4 screws. If you are not able to line up the holes with the beams, use toggle bolts. Make sure the wall bracket is even and flush against the wall.

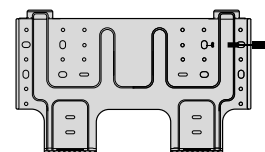

**For Concrete, or similar type wall, make holes into the wall and insert concrete nails instead of screws.**

## MOUNTING THE INDOOR UNIT

The Indoor unit must be mounted before connecting the indoor/outdoor wire, drain hose and copper tubing. To mount, follow the procedures below:

1. The tubing can be extended in 4 directions as shown below. No cutting is necessary for left/rear and right/rear tubing connections. If using left or right tubing connections, remove the plastic area with a hacksaw so pipes can go through.

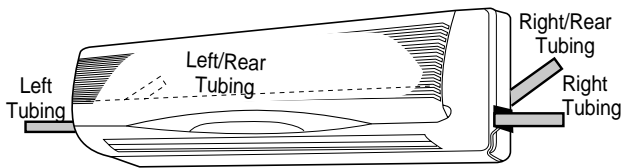

2. Make sure the drain hose and copper tubing are wrapped with the rubber insulation. Using the tape, wrap the indoor/outdoor wire, copper tubing and drain hose together.

### ⚠ CAUTION:

- Make sure the Indoor unit's AC cord is not connected to AC power when performing these procedures.
- Be sure to comply with local codes on running a wire from the indoor to the outdoor unit.
- **DO NOT LET THE INDOOR/OUTDOOR WIRE COME IN DIRECT CONTACT WITH THE TUBING OR HOSE!**

3. Shape the tubing so it can easily go through the hole in the wall. Push the indoor/outdoor wire, copper tubing and drain hose through the hole in the wall angling downward. Situate the indoor unit on the wall bracket by lifting the indoor unit slightly above the wall bracket and then down so it is securely locked in place.

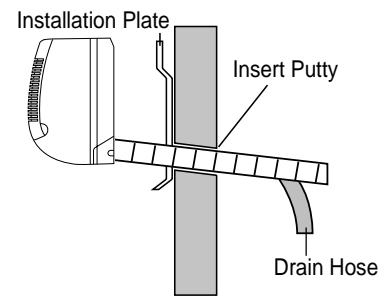

## PREPARING THE COPPER TUBING (NOT INCLUDED)

A copper tubing extension (not included) may need to be cut. If this is the case, it will also have to be deburred and flared as shown below:

1. Cut the copper tube extension to the desired length with a tube cutter. It is highly recommended that 1 foot is added to the requested length. After cutting, deburring may be necessary (see below diagram). Perform this with a tube reamer.

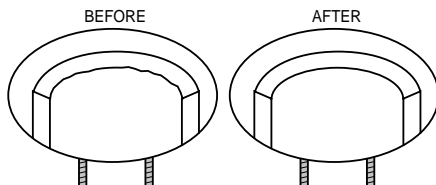

2. Make a flare at the end of the copper tube with a flare tool. Make sure the inside surface and edges are smooth and the sides are uniform length.

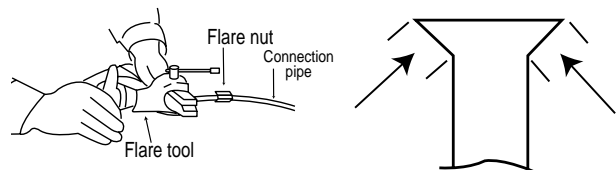

### ⚠ CAUTION:

- When using the tube reamer, hold the tube downward and make sure no copper scraps fall into the tubing.

## CONNECTING THE COPPER TUBES

To connect the copper tubes, follow the procedures below:

1. Remove the flare nut stoppers from the inside unit. Determine the location of the copper tubing and where the bends will be. Gently bend the copper tubing, making sure to use big angles so no crimping will occur. Try to do this on the first try as repeated bending may break or crimp the tubing.



2. Remove the plastic stoppers from the tubing. Connect the large and small copper tubing to the respective extension and rotate the flare nut with your finger until a smooth match is made. Make sure the copper extension has foam rubber (insulation) on it.

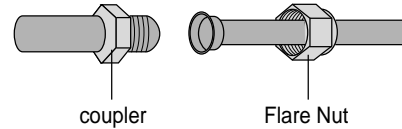

### NOTE:

When removing the flare nut stopper from the inside unit, confirm "Ping" sounds because the mixed gas is charged in the inside unit,

3. Once a smooth match is made, tighten the flare nut using a wrench. Be very careful not to strip the threads or flare nut. Repeat this process for the small and large tubing. When tightening the flare nut, use another wrench to securely hold the coupler from twisting and possibly damaging the tubing.

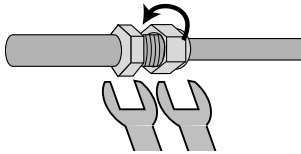

4. Remove the flare nut stoppers from the outdoor unit's valves. Connect the larger copper tubing to the larger valve on the outdoor unit. Connect the smaller copper tubing to the smaller valve on the outdoor unit.

5. Perform a leak test on all copper tube connections. To prevent heat loss and damage to walls from condensation, the copper tube connections coming from the wall must be insulated. Do this by wrapping foam rubber or equivalent around the connection approximately 8mm thick so no copper tubing is exposed.

### NOTES:

- As with all wiring and hookups on this unit, make sure the AC plug on the indoor unit is unplugged.
- Be very careful not to strip the threads or flare nut.
- When insulating the connections, use foam rubber or equivalent.

## CONNECTING THE DRAIN HOSE

To connect the drain hose, follow the procedures below:

1. Connect the drain hose extension to the drain hose coming from the indoor unit by loosening the clamp on the extension using a phillips screwdriver, attaching the hoses together and then tightening the clamp.

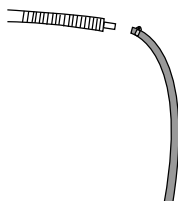

2. Run the drain hose, slanted downward, outside. If the drain pipe is exposed indoors, make sure it is thoroughly insulated so condensation does not ruin walls or furniture or come in contact with the AC connection or extension. Also, do not crease or form a trap in the tubing.

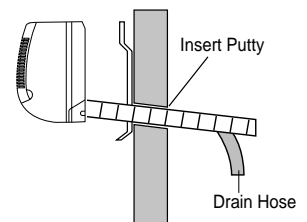

# CONNECTING THE CABLES

One electric power cable must be connected to the outdoor unit. The indoor unit is connected to outdoor unit through the connection cable. To install the cables follow as below.

1. Open the connection cover on the indoor unit.
2. Open the SVC cover on the side of outdoor unit.
3. Connect the connection cable to terminal blocks of the indoor and outdoor unit as shown below.
  - Must be connected with the same terminal number of indoor and outdoor unit.
  - Be sure not to slip the cables out of terminal.
4. Connect the power cable and earth cable.
5. Reinstall the connection cover and the SVC cover.
6. Install the conduit kit. (The conduit kit is optional)

[Connetion Cable]

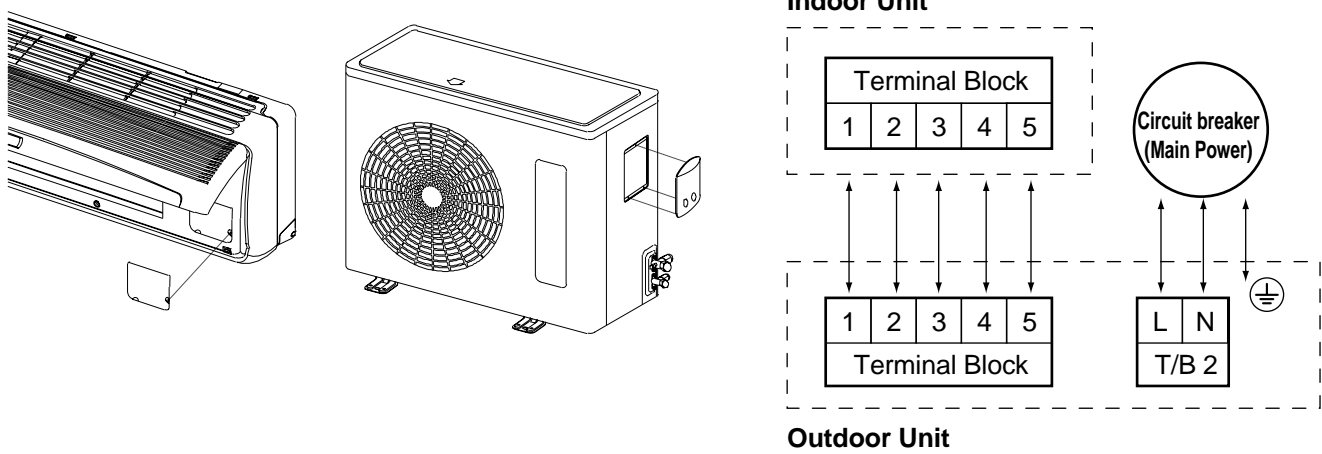

## CAUTION

- The supply voltage must be the same as the rated voltage of air conditioner.
- Prepare the power source for exclusive use with the air conditioner.
- A circuit breaker must be installed between the power source and the unit.
- This air conditioner must be installed according to the national electric rules.

## INFORMATION

- The information for the cables of this air conditioner is as below.

ITEM	SPECIFICATIONS	
POWER CABLE	12K~15K BTU/h	3G AWG 14 SJT or SPT-3
	18K~24K BTU/h	3G AWG 12 SJT or SPT-3
CONNECTION CABLE	12K~24K BTU/h	5G AWG 16~18 SJT 3G AWG 18~20 SJT+2G AWG 16~18 SJT
CONDUIT SIZE	0.875 inch (22.2mm)	

## TAPING UP THE WIRE/TUBES/HOSE

After running the wire, hose and tubing outside, tape them up as shown below to insulate.

1. Tape the two copper tubes, drain hose (and the electrical wiring if local codes permit) together with the supplied tape. Make sure the electrical wiring does not come in direct contact with the copper tubing or drain hose. Approximately 1 foot outside the hole, let the drain hose out and separate from the copper tubing and wiring.

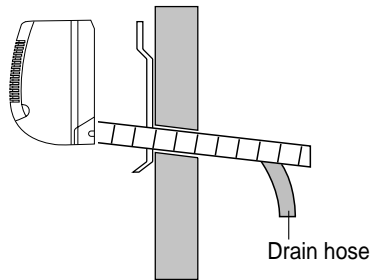

2. Begin wrapping from the point the tubing comes out of the outdoor unit and continue to the hole in the wall. Leave no gaps or breaks and cover the entire length of the tubing. As you wrap, overlap the previous turn by half the width of the tape.

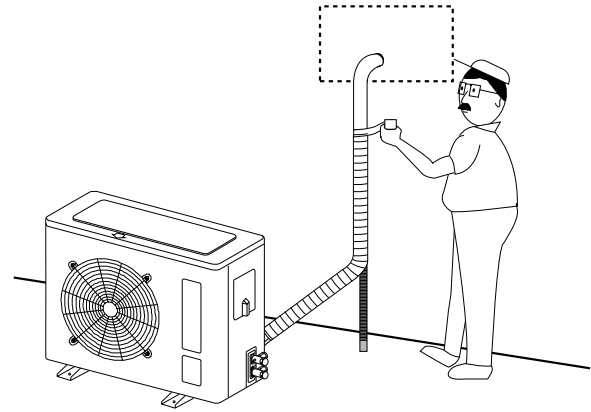

3. Wrap the piping joints with the insulator plate and fasten it with vinyl tape.

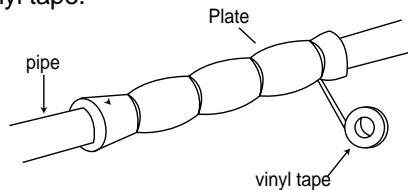

4. After wrapping the connection pipe with tape, fasten it to the outside wall with saddles, etc.

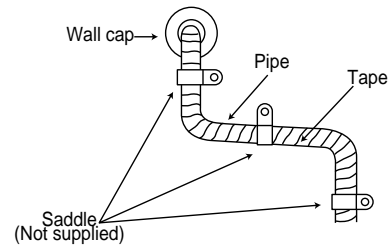

## MOUNTING OUTDOOR UNIT

1. After selection the appropriate site, position the outdoor unit and make sure the space around the outdoor unit. (See overview instruction of installation)
2. Mount the outdoor unit on appropriate base using anchor bolts.
3. Install the CUSHION RUBBER provided to prevent vibration and noise.
4. If the outdoor unit is expose to direct sunlight or strong wind, install shield around the outdoor units.

\* The outdoor unit must be installed on stable and rigid base.

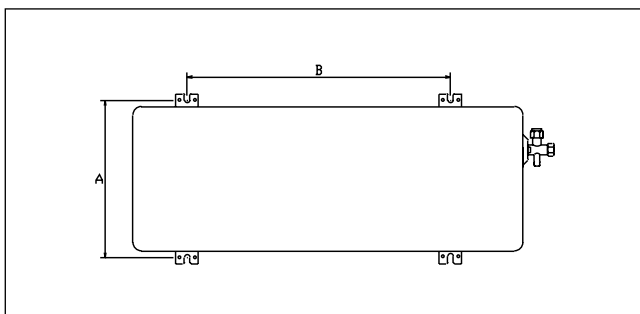

(inch)

Model	A	B
TAS-12/15/18H	14.17	22.83
TAS-24H	13.78	21.65

## APPLYING PUTTY AND INSERTING THE WALL CAP

After running the wires and tubing outside, putty should be inserted around the opening on the outside to protect against rain, wind, etc. To apply putty, see below:

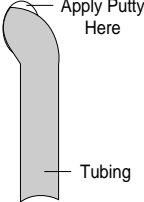
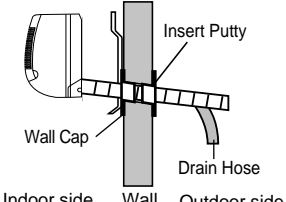
<p>1. Apply the putty to any area on the outside hole that air or rain can get into.</p> 	<p>2. After applying putty, insert the wall Cap at Indoor side and Outdoor side.</p> 
----------------------------------------------------------------------------------------------------------------------------------------------------------------------------	--------------------------------------------------------------------------------------------------------------------------------------------------------------------------

## AIR PURGING

Air and moisture remaining in the refrigerant system may create adverse conditions as indicated below:

- pressure in the system rises
- operating current rises
- cooling efficiency drops
- moisture in the refrigerant circuit may freeze and block capillary tubing
- water may lead to corrosion of parts in the refrigerant system

Therefore, the indoor unit and tubing between the indoor and outdoor unit must be leak tested and evacuated to remove any noncondensables and moisture from the system.

## AIR PURGING WITH VACUUM PUMP (TEST RUN)

Confirm each tube (narrow and wide tubes) between the indoor and outdoor units has been properly connected and all wiring for the test run has been completed. Remove the valve caps from the wide and narrow service valves on the outdoor unit. Note that both narrow and wide tube service valves on the outdoor unit are kept closed at this stage (shipping position).

### Leak Test

1. With the service valves on the outdoor unit remaining closed, remove the threaded cover on the wide tube service port. (Save for reuse.)
2. Attach a manifold valve (with pressure gauge) and dry nitrogen gas cylinder to this service port with charge hoses.

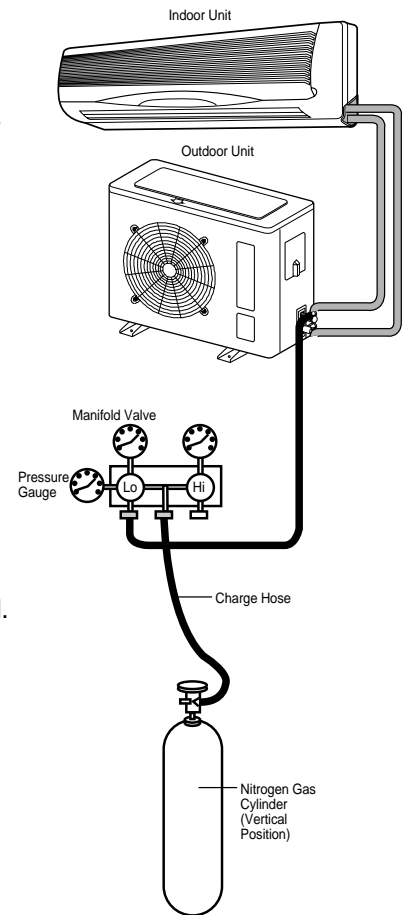

### CAUTION:

Be sure to use a manifold valve for air purging. If it is not available, use a stop valve for this purpose. The Hi knob of the manifold valve must always be kept closed.

3. Pressurize the system to no more than 150 P.S.I.G. with dry nitrogen gas and close the cylinder valve when the gauge reading reaches 150 P.S.I.G. Next, test for leaks with liquid soap.

### CAUTION:

To avoid nitrogen entering the refrigerant system in a liquid state, the top of the nitrogen gas cylinder must be higher than its bottom when you pressurize the system. Usually, the cylinder is used in a vertical standing position.

4. Do a leak test of all joints of the tubing (both indoor and outdoor) and both wide and narrow service valves. Bubbles indicate a leak. Be sure to wipe off the soap with a clean cloth.
5. After the system is found to be free of leaks, relieve the nitrogen pressure by loosening the charge hose connector at the nitrogen cylinder. When the system pressure is reduced to normal, disconnect the hose from the cylinder.

## Evacuation

1. Attach the charge hose end described in the leak test area to a vacuum pump to evacuate the tubing and indoor unit. Confirm the Lo knob of the manifold valve is open. Then, run the vacuum pump. The operation time for evacuation varies with the tubing length and capacity of the pump. The following table shows the amount of time for evacuation:

Required time for evacuation when 30 gal/h vacuum pump is used	
If tubing length is less than 33 ft. (10 m)	If tubing length is longer than 33 ft. (10 m)
<b>10 min. or more</b>	<b>15 min. or more</b>

2. When the desired vacuum is reached, close the Lo knob of the manifold valve and stop the vacuum pump.

## Finishing the job

1. With a hex wrench, turn the narrow tube service valve stem counter-clockwise to fully open the valve.
2. Turn the wide tube service valve stem counter-clockwise to fully open the valve.

## CAUTION:

To avoid gas from leaking when removing the charge hose, make sure the wide tube service valve is fully open and turned all the way out.

3. Loosen the charge hose connected to the wide tube service port slightly to release the pressure, then remove the hose.
4. Replace the threaded cover on the wide tube service port and fasten it securely. This process is very important to prevent gas from leaking from the system.
5. Replace the valve caps at both wide and narrow service valves and fasten them securely.

This completes air purging with a vacuum pump. The air conditioner is now ready to test run..

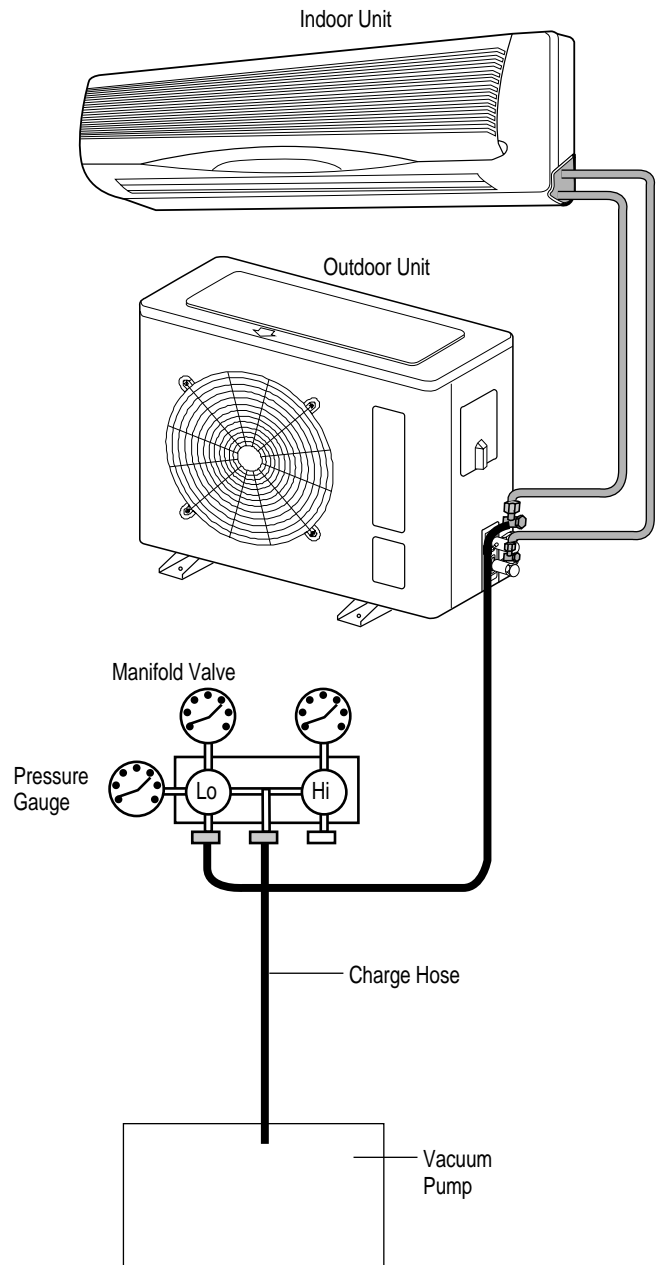

---

## TEST RUN

---

Check that all tubing and wiring have been completed correctly. Check again that the wide and narrow tube service valves are fully opened. Turn on the power and run the system.

### Service Valve Construction

- **Valve Position Closed**

The valve systems of both the wide and narrow tubes are turned all the way in. The unit is shipped from the factory in this position and it is also used for Pump Down and Air Purging.

- **Valve Position Fully Open**

The valve stems of both the wide and narrow tubes are turned all the way out. This is normal operating and Test Run position.

- **Valve Position Half Open**

With the narrow tube valve stem is turned to the halfway-down position. This position is used for pressure measurement and gas charging.

#### **CAUTION:**

When opening or closing the service valve stem, be sure to use a hex wrench.

---

## PUMP DOWN

---

Pump Down means collecting all refrigerant in the outdoor unit without loss in refrigerant gas.

This is performed when the unit is to be relocated or the refrigerant circuit is serviced.



#### **CAUTION:**

Be sure to perform Pump Down procedure with the unit cooling mode.

### Pump Down Procedure

1. Connect a low-pressure gauge manifold hose to the charge port on the wide tube service valve.
2. Open the wide tube service valve halfway and purge the air from the manifold hose using the refrigerant gas.
3. Close the narrow tube service valve (all the way in).
4. Turn on the unit's operating switch and start the cooling operation.
5. When the low-pressure gauge reading becomes 1 to 0.5 kg/cm<sup>2</sup> (14.2 to 7.1 psi), fully close the wide tube valve stem and then quickly turn off the unit. At that time, Pump Down has been completed and all refrigerant gas will have been collected in the outdoor unit.

# 3. REFRIGERANT CYCLE DIAGRAM

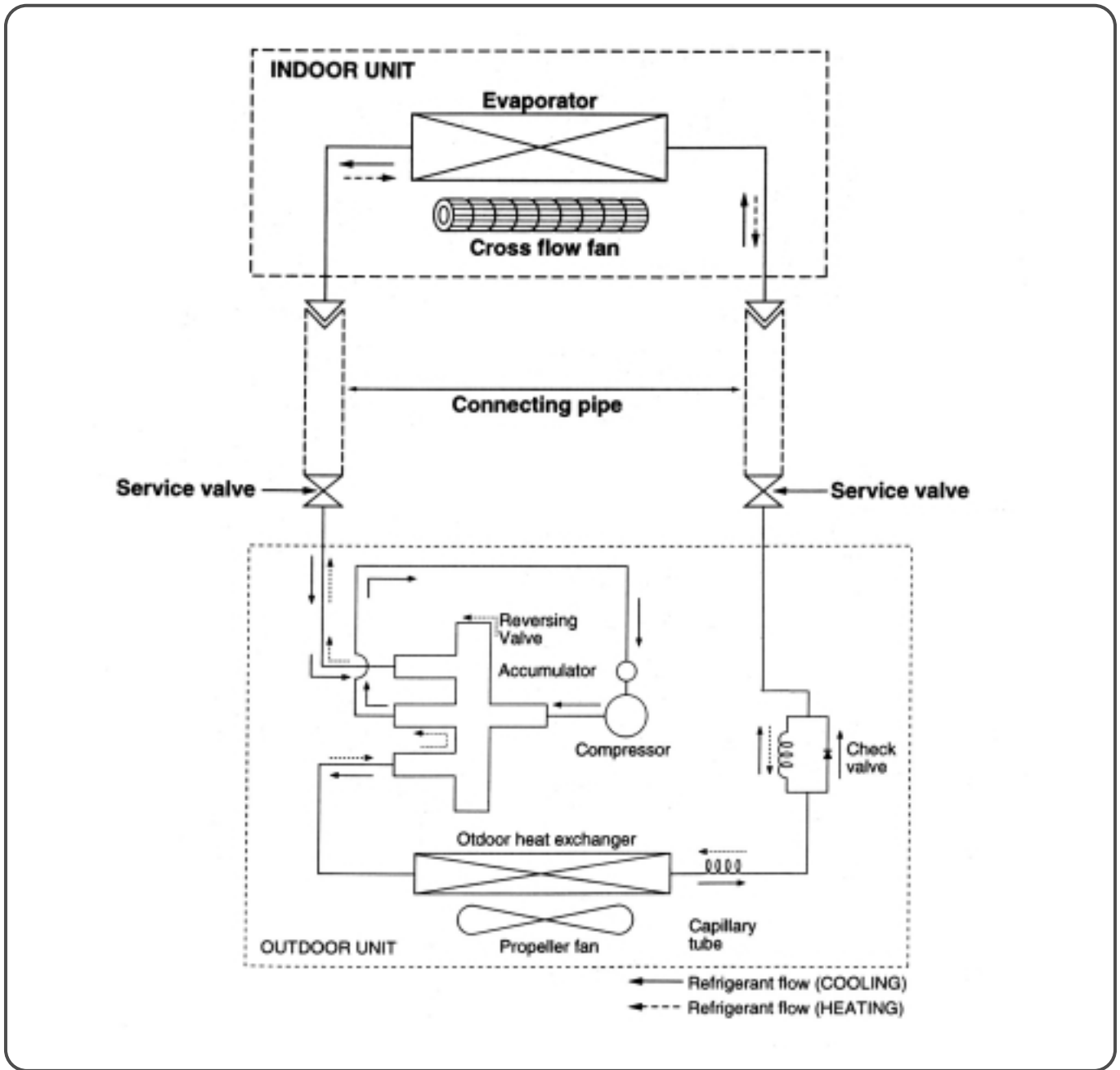

Pipe Size (Dimension-inch)			Max. Piping length	Max. Piping elevation
Model No.	Gas	Liquid		
TAS-12H	3/8"	1/4"	33~49 ft	16.5~23 ft
TAS-15, 18H	1/2"	1/4"		
TAS-24H	5/8"	3/8"		

# 4. WIRING DIAGRAM

## • Indoor Unit

### ◆ TAS-12/18/24H

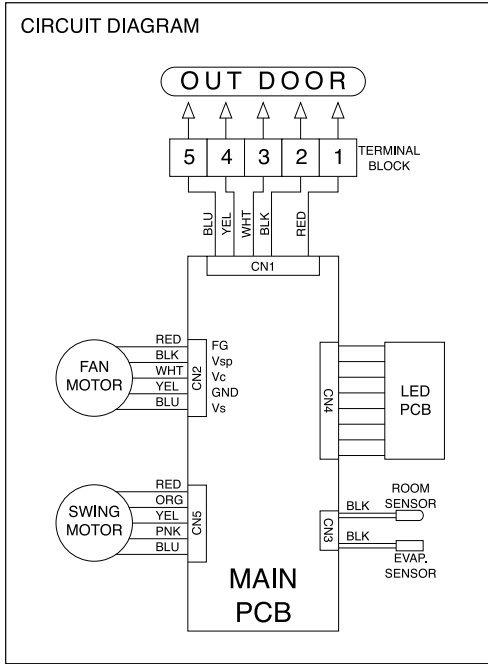

### ◆ TAS-15H

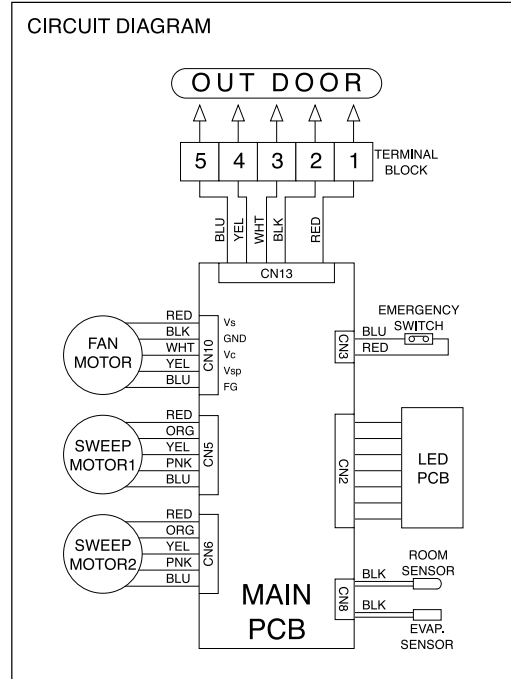

## • Outdoor Unit

### ◆ TAS-12/15/18HO

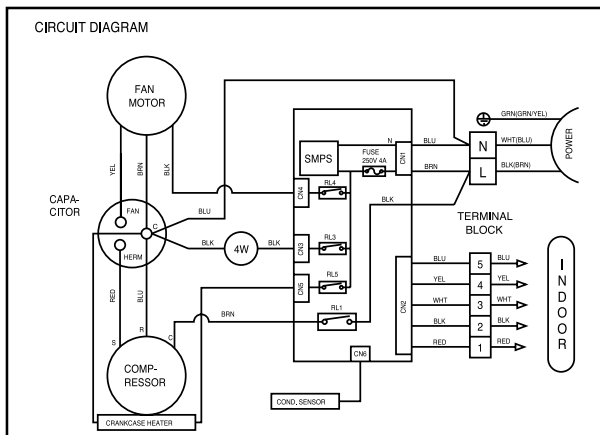

### ◆ TAS-24HO

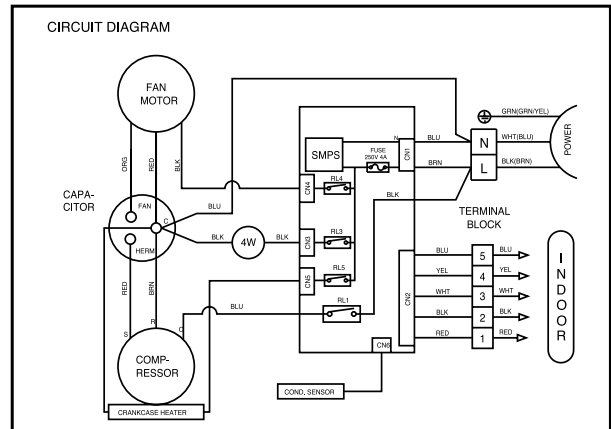

# 5. CONTROL BLOCK DIAGRAM

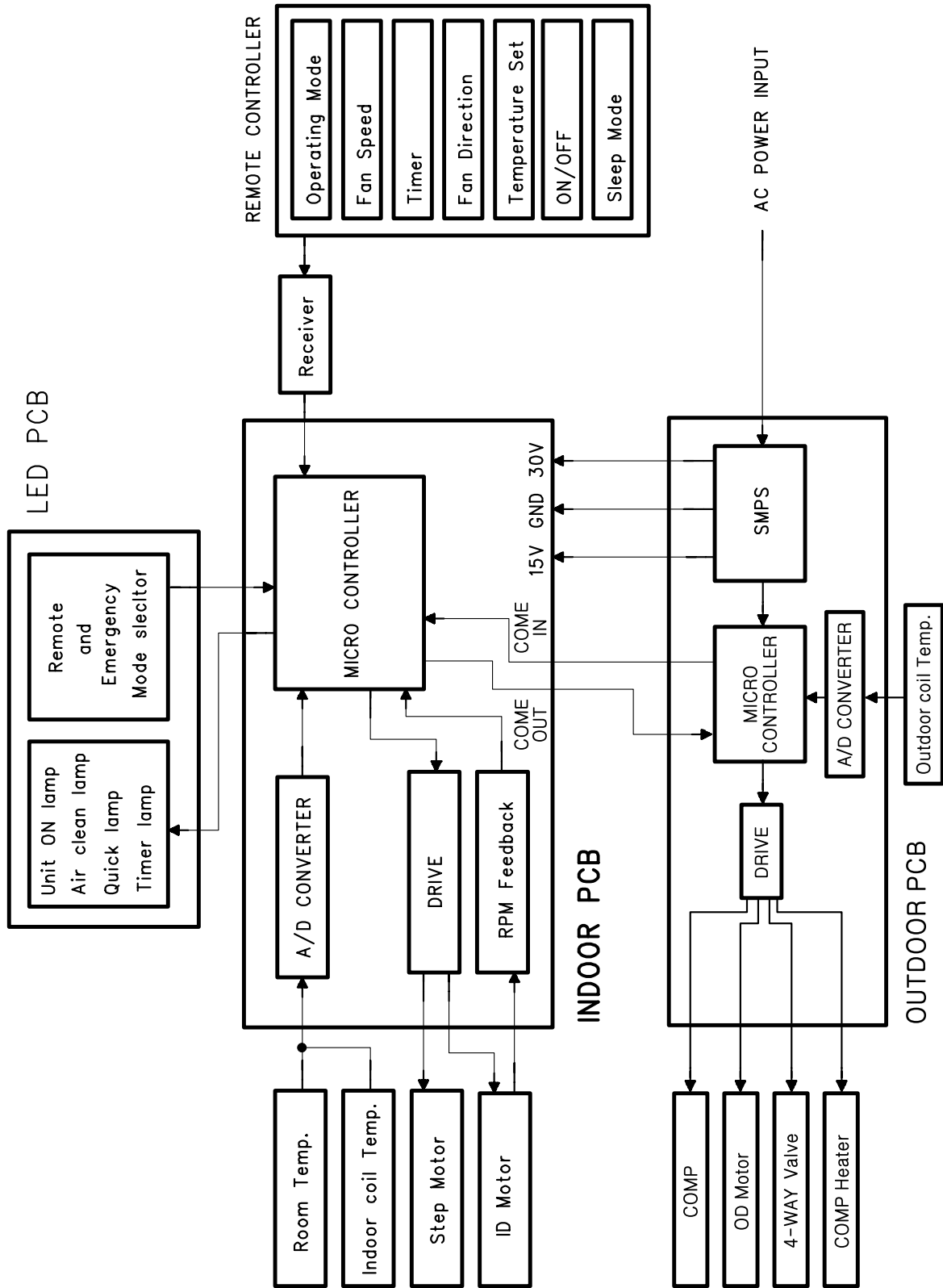

# 6. TROUBLE SHOOTING

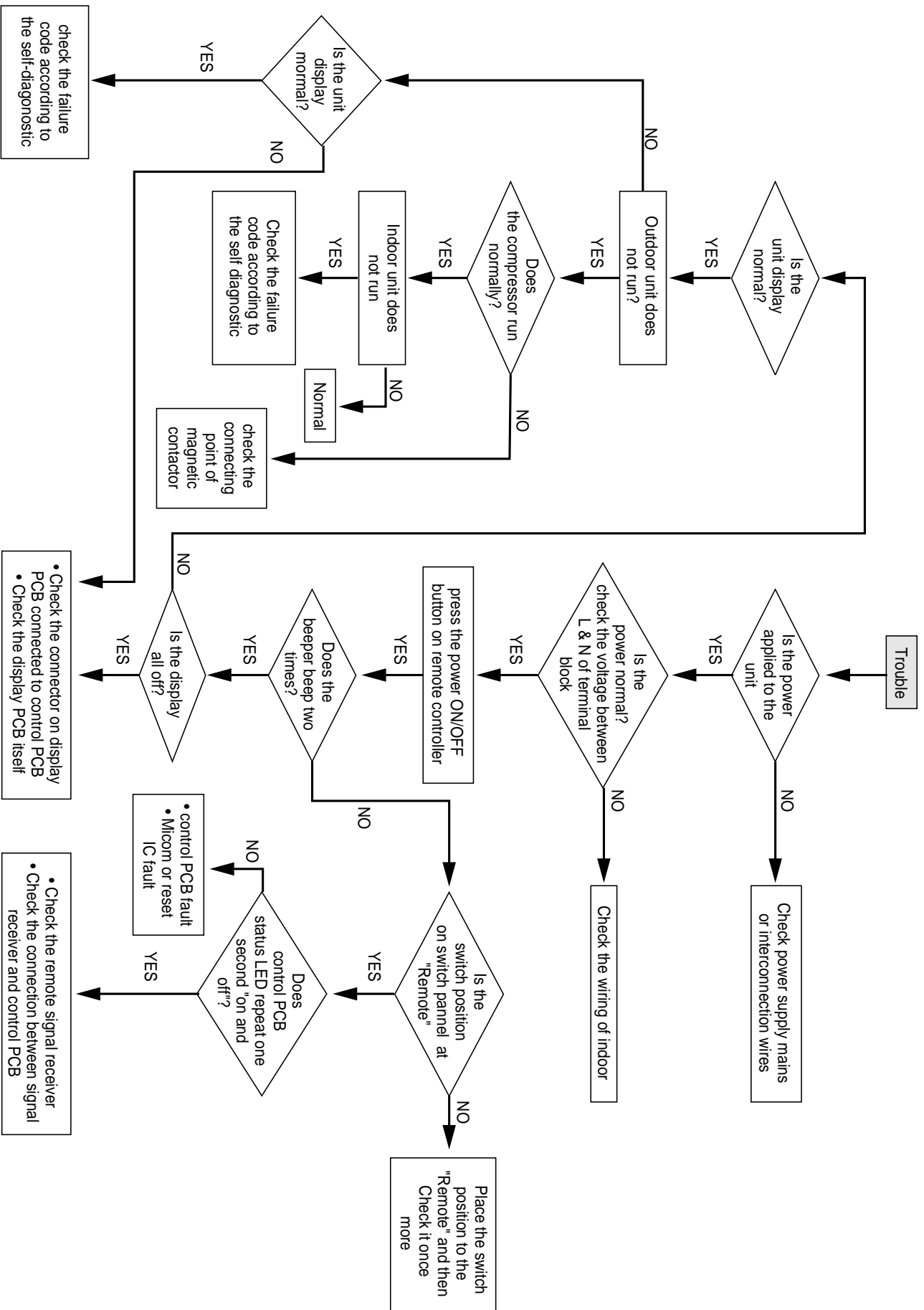

**Note 1)**

- ① Neither indoor unit nor outdoor unit runs.  
Check the following points first. (There are following case in normal operation)
  - a. Is the timer mode set the "timer ON".
  - b. Is the timer mode set the "timer-OFF" and the time had passed?
- ② Neither outdoor fan nor compressor runs while indoor fan runs.  
Check following points first. (There are following cases in normal operation)
  - a. Is the temperature set point suitable?
  - b. Has the 3 minutes time guard for compressor operated?

## Self-Diagnostic Function

1. Error Code I - ON LED blinking 3 times at Emergency Mode
  - ① When the compressor do not run.
    - i) Check the voltage between **L** and **Y** of terminal block.  
(Indoor Unit, Outdoor Unit)
    - ii) Check connecting wire of indoor unit and outdoor unit.
    - iii) Check relay RL1 on power P.C.B (outdoor PCB)
  - ② Check fixing of indoor coil thermistor.
  - ③ Check the GAS LEAKAGE of the pipe.
2. Error Code 2 - ON LED blinking
  - ① Check the sensor and its circuit.
  - ② It occurs when sensor is open or short.
3. Error Code 3 – TIMER LED blinking
  - ① Check the Indoor Fan Motor.
  - ② Check the RPM feedback circuit.
  - ③ Indoor Fan Motor does not work for 5 seconds.
4. Error Code 4 – QUICK LED blinking
  - ① Check the Communication system between Indoor unit and Outdoor unit.

## Neither Indoor Unit nor Outdoor Unit Runs

Confirm following statement.

When the unit operate normally, Sometimes the outdoor unit and indoor unit cannot operate.

- ① Check the function select switch. Is it timer mode?
- ② The function select switch locate the sleep mode and is the setting time over?
- ③ Is the setting mode DEHUMIDIFIER mode?

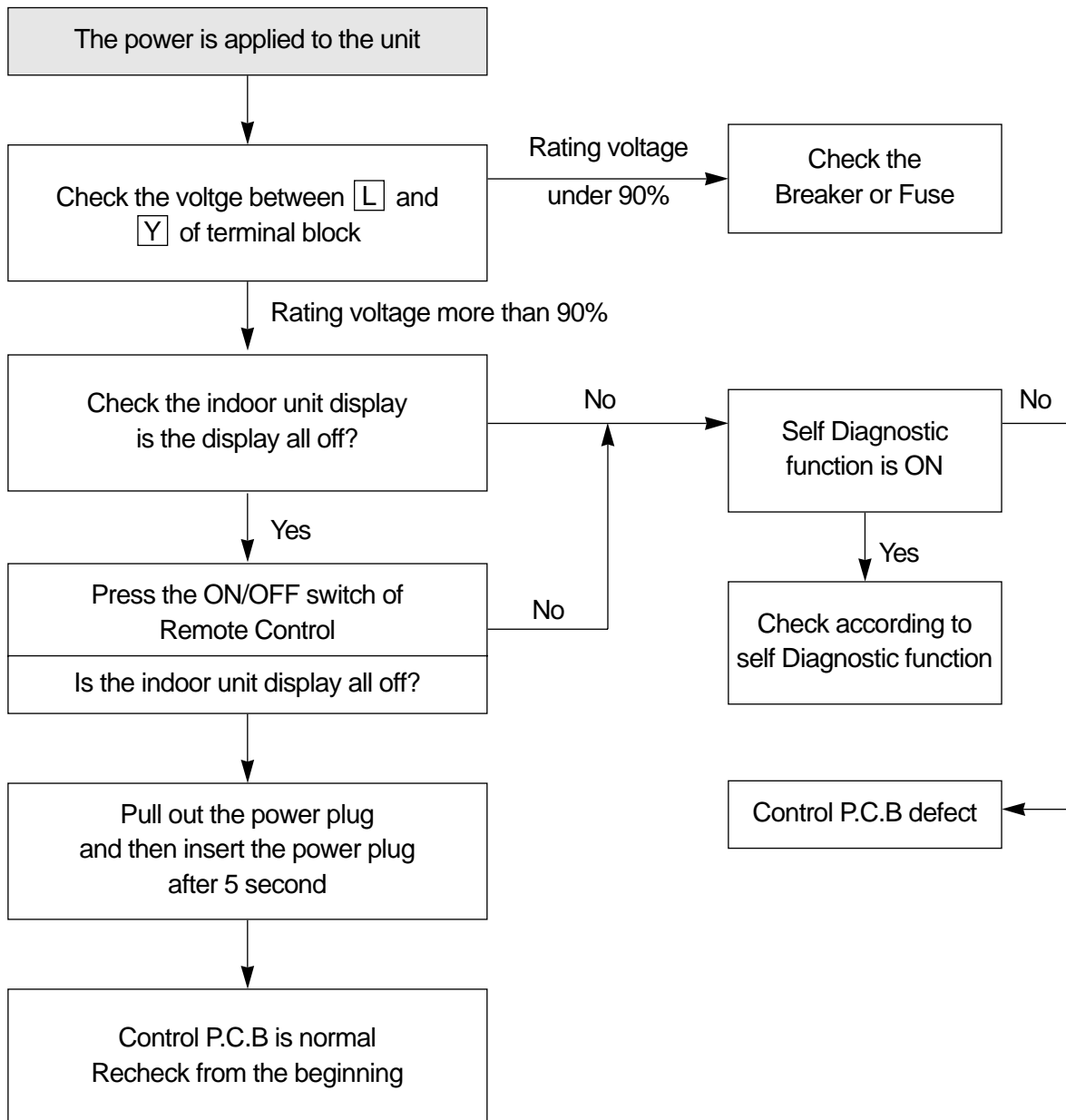

# Outdoor Unit Runs but Indoor Fan Do Not Run

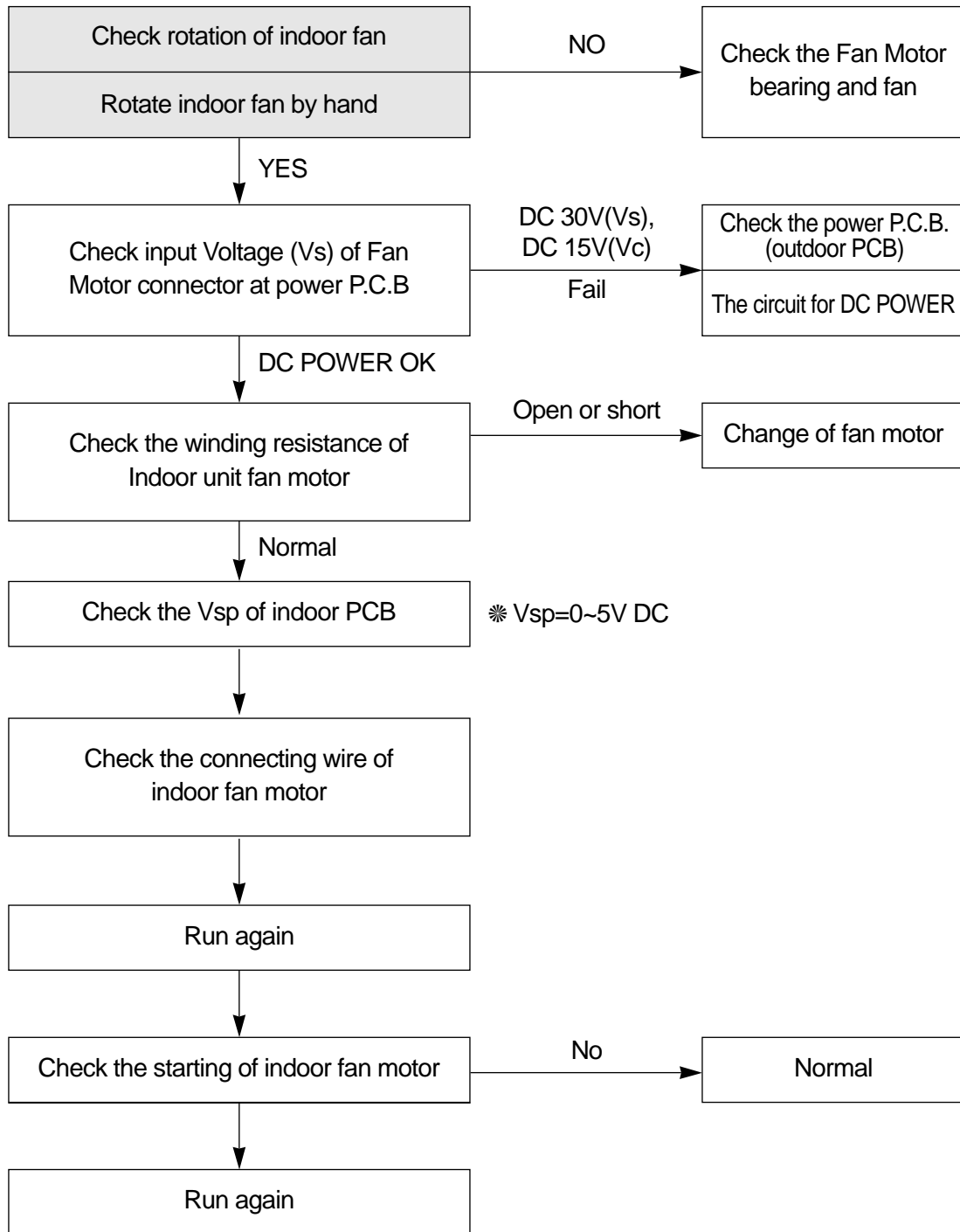

## Outdoor Fan and Compressor Do Not

Confirm following statement.

When the unit operate normally, Sometimes the outdoor unit and indoor unit cannot operate.

- ① Is the setting temperature proper?
- ② Is the unit during 3min. Time delay of compressor.
- ③ During frost prevention of Indoor unit.

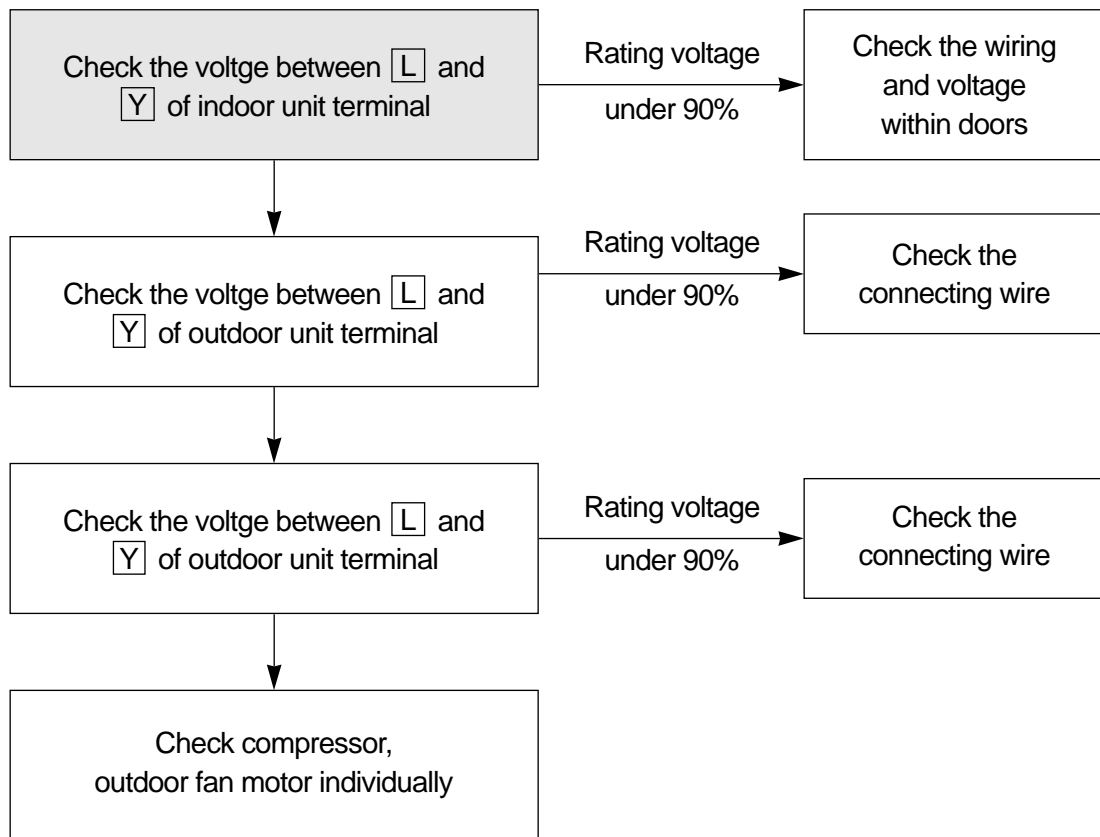

# Only Compressor Do not Run

- Check the following at cooling mode

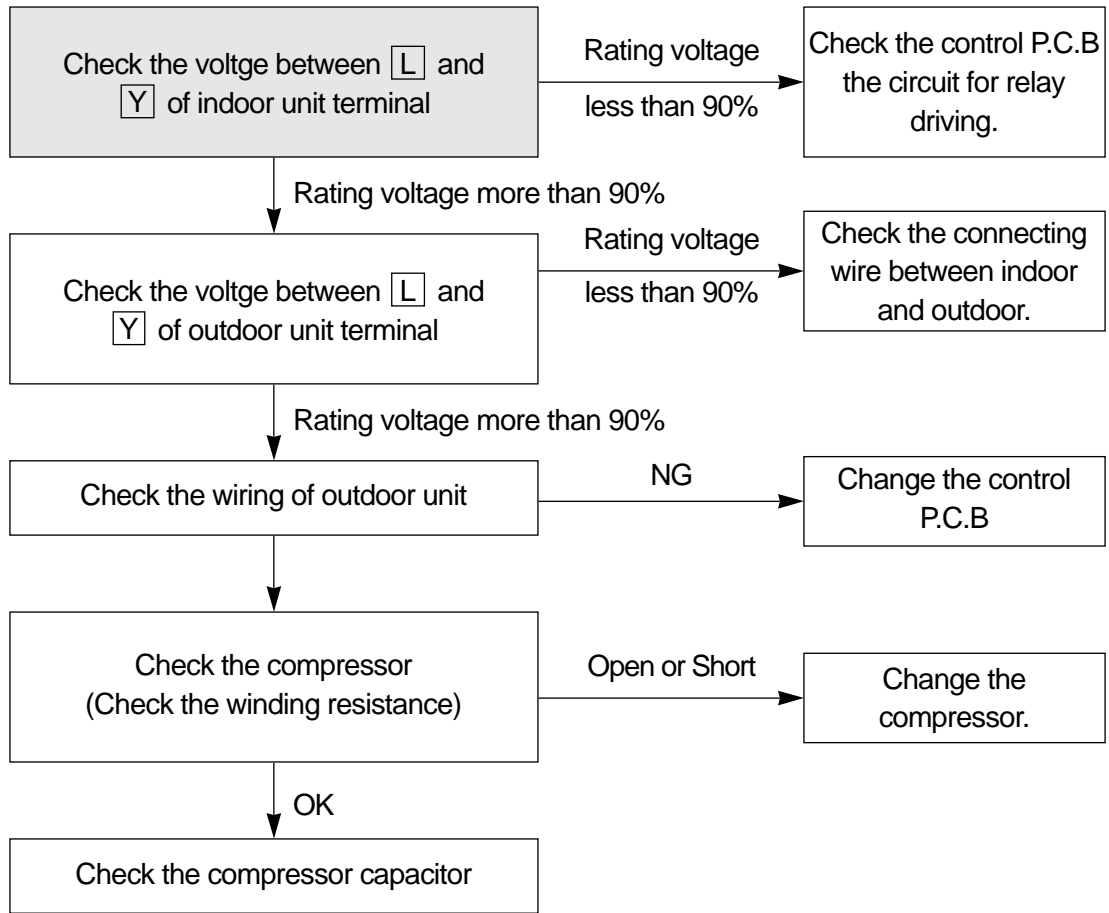

# 7. PCB DESCRIPTION

## 1 PCB CIRCUIT DIAGRAM

◆ TAS-12/18/24H (Indoor Unit)

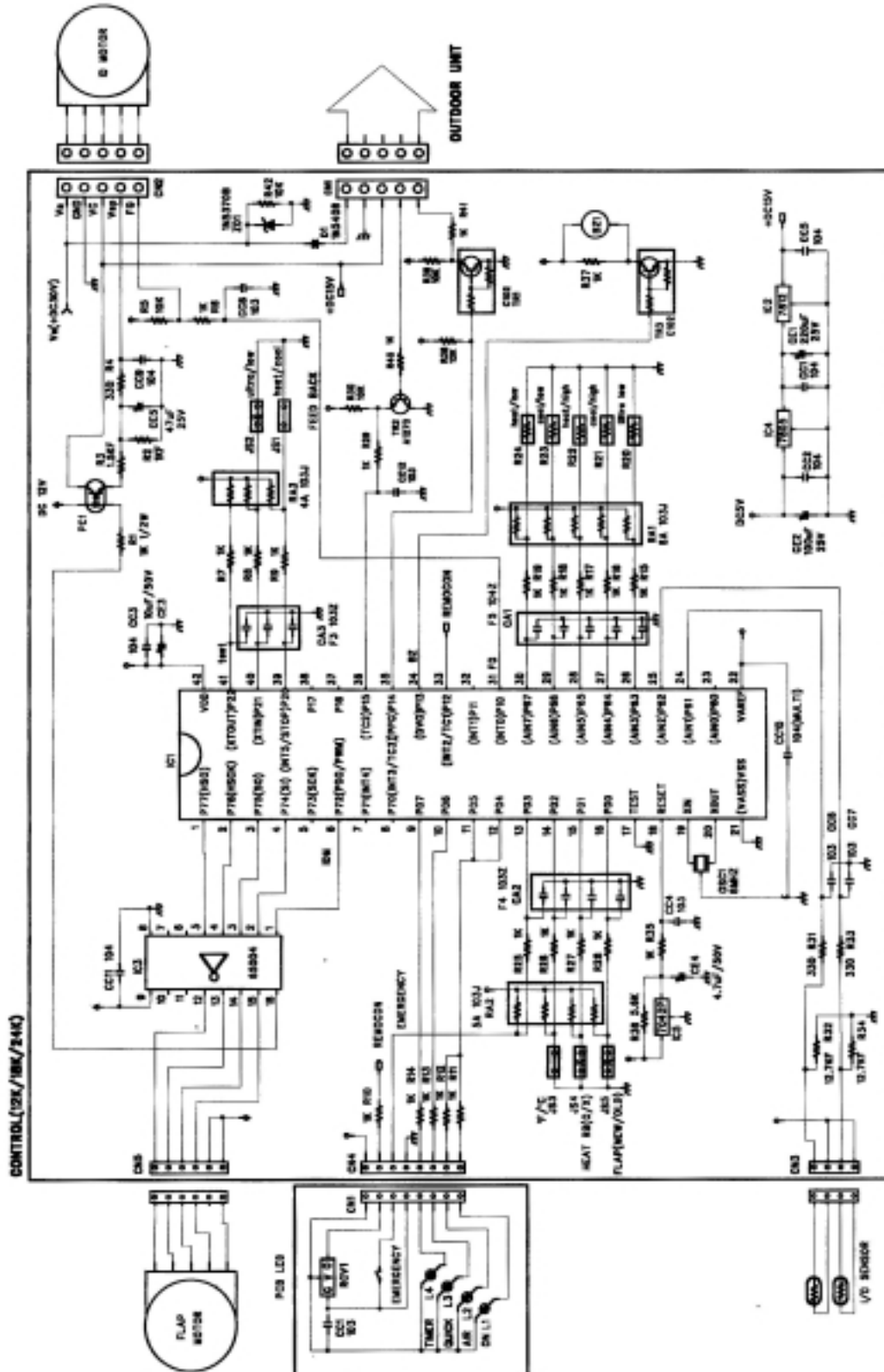

◆ TAS-15H (Indoor Unit)

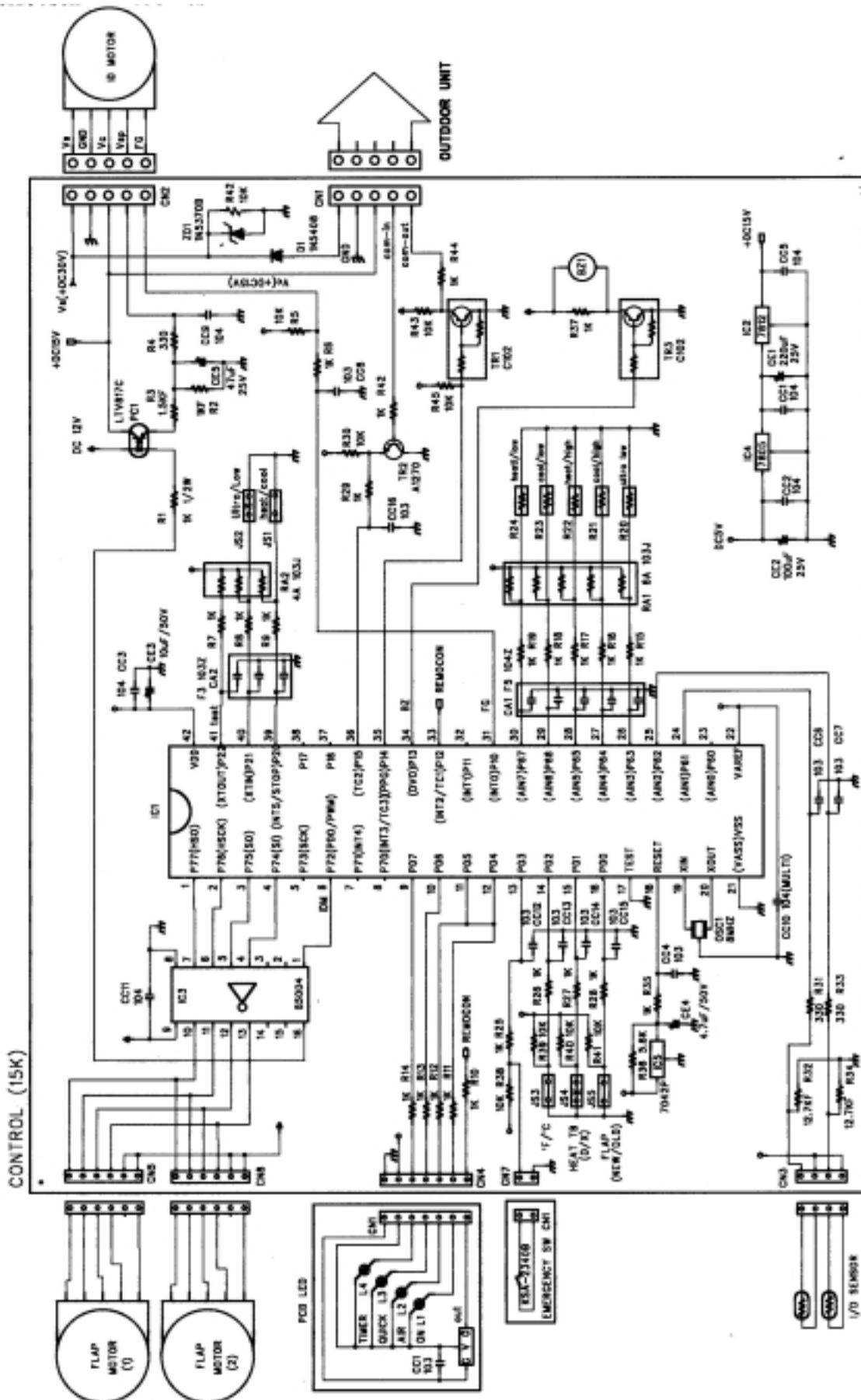

◆ TAS-12HO/15HO/18HO/24HO (Outdoor Unit)

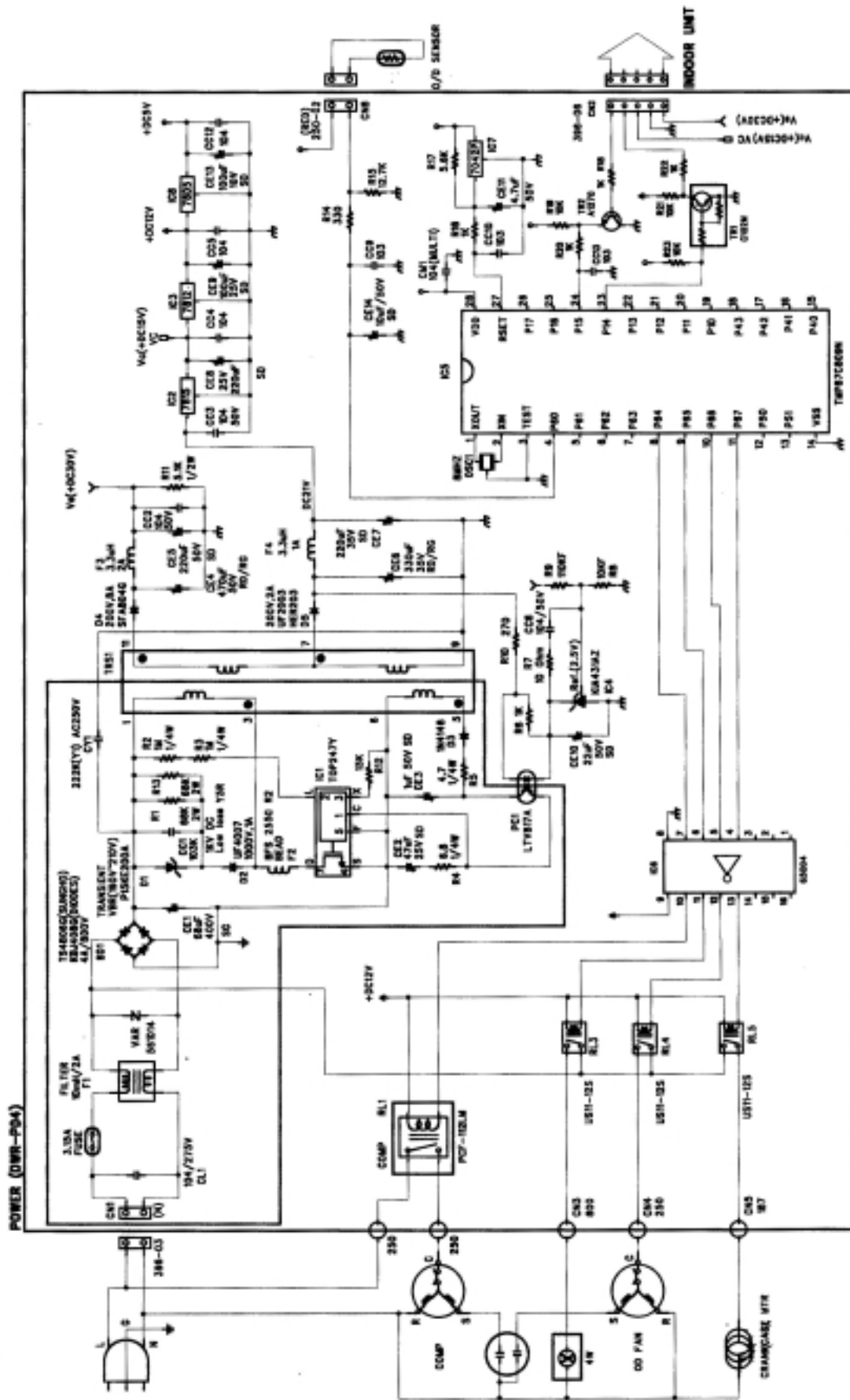

## ◆PART LIST OF INDOOR PCB (TAS-12H/18H/24H)

✓ **Caution** : In this Manual, some parts can be changed for improving, their performance without notice in the parts list. So, if you need the latest parts information, please refer to PPL(Parts Price List) in Service Information Center (<http://svc.dwe.co.kr>).

Location	Code	Q'ty			Part Name	Description	Unit
		12H	18H	24H			
CN1	3108803200	1	1	1	WAFER	YW396-06V	EA
CN2	3108803100	1	1	1	WAFER	YW396-05V	EA
CN3	3118702310	1	1	1	WAFER	YMAW025-04R	EA
CN4	3108804800	1	1	1	WAFER	SMAW250-08	EA
CN5	3118700800	1	1	1	WAFER	SMAW250-06	EA
R1	RD-2K102J-	1	1	1	R CARBON FILM	1/2W 1K OHM J	EA
R2	RN-4K1001F	1	1	1	R METAL FILM	1/4W 1K OHM F	EA
R3	RN-4K1501F	1	1	1	R METAL FILM	1/4W 1.5K OHM F	EA
R4	RD-4K331J-	1	1	1	R CARBON FILM	1/4W 330 OHM J	EA
R5	RD-4K103J-	1	1	1	R CARBON FILM	1/4W 10K OHM J	EA
R6	RD-4K102J-	1	1	1	R CARBON FILM	1/4W 1K OHM J	EA
R7	RD-4K102J-	1	1	1	R CARBON FILM	1/4W 1K OHM J	EA
R8	RD-4K102J-	1	1	1	R CARBON FILM	1/4W 1K OHM J	EA
R9	RD-4K102J-	1	1	1	R CARBON FILM	1/4W 1K OHM J	EA
R10	RD-4K102J-	1	1	1	R CARBON FILM	1/4W 1K OHM J	EA
R11	RD-4K102J-	1	1	1	R CARBON FILM	1/4W 1K OHM J	EA
R12	RD-4K102J-	1	1	1	R CARBON FILM	1/4W 1K OHM J	EA
R13	RD-4K102J-	1	1	1	R CARBON FILM	1/4W 1K OHM J	EAa
R14	RD-4K102J-	1	1	1	R CARBON FILM	1/4W 1K OHM J	EA
R15	RD-4K102J-	1	1	1	R CARBON FILM	1/4W 1K OHM J	EA
R16	RD-4K102J-	1	1	1	R CARBON FILM	1/4W 1K OHM J	EA
R17	RD-4K102J-	1	1	1	R CARBON FILM	1/4W 1K OHM J	EA
R18	RD-4K102J-	1	1	1	R CARBON FILM	1/4W 1K OHM J	EA
R19	RD-4K102J-	1	1	1	R CARBON FILM	1/4W 1K OHM J	EA
R20	RN-4K6192F	1	1	1	R METAL FILM	1/4W 61.9K OHM F	EA
R21	RN-4K5761F	1	1	1	R METAL FILM	1/4W 5.76K OHM F	EA
R22	RN-4K5761F	1	-	1	R METAL FILM	1/4W 5.76K OHM F	EA
	3109400100	-	1	-	JUMPER	10mm	EA
R23	RN-4K2432F	1	1	1	R METAL FILM	1/4W 24.3K OHM F	EA
R24	RN-4K2432F	1	-	1	R METAL FILM	1/4W 24.3K OHM F	EA
	RN-4K8251F	-	1	-	R METAL FILM	1/4W 8.25K OHM F	EA
R25	RD-4K102J-	1	1	1	R CARBON FILM	1/4W 1K OHM J	EA
R26	RD-4K102J-	1	1	1	R CARBON FILM	1/4W 1K OHM J	EA
R27	RD-4K102J-	1	1	1	R CARBON FILM	1/4W 1K OHM J	EA
R28	RD-4K102J-	1	1	1	R CARBON FILM	1/4W 1K OHM J	EA
R29	RD-4K102J-	1	1	1	R CARBON FILM	1/4W 1K OHM J	EA
R30	RD-4K103J-	1	1	1	R CARBON FILM	1/4W 10K OHM J	EA
R31	RD-4K331J-	1	1	1	R CARBON FILM	1/4W 330 OHM J	EA
R32	RN-4K1272F	1	1	1	R METAL FILM	1/4W 12.7K OHM F	EA
R33	RD-4K331J-	1	1	1	R CARBON FILM	1/4W 330 OHM J	EA
R34	RN-4K1272F	1	1	1	R METAL FILM	1/4W 12.7K OHM F	EA
R35	RD-4K102J-	1	1	1	R CARBON FILM	1/4W 1K OHM J	EA
R36	RD-4K562J-	1	1	1	R CARBON FILM	1/4W 5.6K OHM J	EA
R37	RD-4K102J-	1	1	1	R CARBON FILM	1/4W 1K OHM J	EA

Location	Code	Q'ty			Part Name	Description	Unit
		12H	18H	24H			
R38	RD-4K103J-	1	1	1	R CARBON FILM	1/4W 10K OHM J	EA
R39	RD-4K103J-	1	1	1	R CARBON FILM	1/4W 10K OHM J	EA
R40	RD-4K102J-	1	1	1	R CARBON FILM	1/4W 1K OHM J	EA
R41	RD-4K102J-	1	1	1	R CARBON FILM	1/4W 1K OHM J	EA
R42	RD-4K103J-	1	1	1	R CARBON FILM	1/4W 10K OHM J	EA
CC1	CCXE1H104M	1	1	1	C-CERA	104M 50V DC	EA
CC2	CCXE1H104M	1	1	1	C-CERA	104M 50V DC	EA
CC3	CCXE1H104M	1	1	1	C-CERA	104M 50V DC	EA
CC4	CCXE1H103M	1	1	1	C-CERA	103M 50V DC	EA
CC5	CCXE1H104M	1	1	1	C-CERA	104M 50V DC	EA
CC6	CCXE1H103M	1	1	1	C-CERA	103M 50V DC	EA
CC7	CCXE1H103M	1	1	1	C-CERA	103M 50V DC	EA
CC8	CCXE1H103M	1	1	1	C-CERA	103M 50V DC	EA
CC9	CCXE1H104M	1	1	1	C-CERA	104M 50V DC	EA
CC10	CDXE1H104M	1	1	1	C-MULTI	104Z,CRO561B-Z5U	EA
CC11	CCXE1H104M	1	1	1	C-CERA	104M 50V DC	EA
CC12	CCXE1H103M	1	1	1	C-CERA	103M 50V DC	EA
CE1	CEXE1E227C	1	1	1	C-ELEC	220uF 25V SD(SG)	EA
CE2	CEXE1E107C	1	1	1	C-ELEC	100uF 25V SD(SG)	EA
CE3	CEXE1H106C	1	1	1	C-ELEC	10uF 50V SD(SG)	EA
CE4	CEXE1H475C	1	1	1	C-ELEC	4.7uF 50V SD(SG)	EA
CE5	CEXE1E476C	1	1	1	C-ELEC	47uF 25V SD(SG)	EA
RA1	RA8K5103J-	1	1	1	R-ARRAY	6P(5)X 103J	EA
RA2	RA8K4103J-	1	1	1	R-ARRAY	5P(4)X 103J	EA
RA3	RA8K3103J-	1	1	1	R-ARRAY	4P(3)X 103J	EA
CA1	CN5XD104M-	1	1	1	C-ARRAY	6P(F5)X 104Z	EA
CA2	CN4XD104M-	1	1	1	C-ARRAY	5P(F4)X 104Z	EA
CA3	CN3XD104M-	1	1	1	C-ARRAY	4P(F3)X 104Z	EA
D1	DZN5408---	1	1	1	DIODE	1N5408, 1000V/3.0A	EA
ZD1	DZN5370B--	1	1	1	DIODE ZENER	1N5370B, 56V/2.3A	EA
JS1	3109400100	1	1	1	JUMPER	10mm	EA
JS3	3109400100	1	1	1	JUMPER	10mm	EA
PC1	1LTV817C--	1	1	1	IC PHOTOCOUPLER	LTV817C	EA
BZ1	3105698200	1	1	1	BUZZER	DP-2520BA, BM-20K	EA
OSC1	5PRT800MG-	1	1	1	RESONATOR	RT8.00MG	EA
IC4	1KA78L05F-	1	1	1	IC REGULATOR	KA78L05F	EA
IC5	1KA7042P--	1	1	1	IC RESET	KIA7042P 5L	EA
TR1	TKRC102M--	1	1	1	TR	KRC 102-M	EA
TR2	TZTA1270Y-	1	1	1	TR	KTA1270Y	EA
TR3	TKRC102M--	1	1	1	TR	KRC 102-M	EA
PCB	3114308220	1	-	-	PCB CONTROL	TAS-12H(176.5*121*1.6T,FR1)	EA
PCB	3114308420	-	1	1	PCB CONTROL	TAS-18/24H(163.25*123*1.6T,FR1)	EA
IC1	13GS87PH46	1	1	1	IC MICOM	TMP87PH46N(OTP)	EA
IC2	1L7812CV--	1	1	1	IC REGULATOR	7812	EA
IC3	13GT62004A	1	1	1	IC DRIVER	ULN2004A	EA

## ◆PART LIST OF INDOOR PCB (TAS-15H)

✓ **Caution** : In this Manual, some parts can be changed for improving, their performance without notice in the parts list. So, if you need the latest parts information, please refer to PPL(Parts Price List) in Service Information Center (<http://svc.dwe.co.kr>).

Location	Part Code	Q'ty	Part Name	Description	Unit
CN1	3108803200	1	WAFER	YW396-06V	EA
CN2	3108803100	1	WAFER	YW396-05V	EA
CN3	3118702330	1	WAFER	YMW025-04R	EA
CN4	3108804100	1	WAFER	SMW250-07	EA
CN5	3108802000	1	WAFER	SMW250-06	EA
CN7	3108804230	1	WAFER	SMW250-02	EA
CN8	3108802000	1	WAFER	SMW250-06	EA
R1	RD-2K102J-	1	R CARBON FILM	1/2W 1K OHM J	EA
R2	RN-4K1001F	1	R METAL FILM	1/4W 1K OHM F	EA
R3	RN-4K1501F	1	R METAL FILM	1/4W 1.5K OHM F	EA
R4	RD-4K331J-	1	R CARBON FILM	1/4W 330 OHM J	EA
R5	RD-4K103J-	1	R CARBON FILM	1/4W 10K OHM J	EA
R6	RD-4K102J-	1	R CARBON FILM	1/4W 1K OHM J	EA
R7	RD-4K102J-	1	R CARBON FILM	1/4W 1K OHM J	EA
R8	RD-4K102J-	1	R CARBON FILM	1/4W 1K OHM J	EA
R9	RD-4K102J-	1	R CARBON FILM	1/4W 1K OHM J	EA
R10	RD-4K102J-	1	R CARBON FILM	1/4W 1K OHM J	EA
R11	RD-4K102J-	1	R CARBON FILM	1/4W 1K OHM J	EA
R12	RD-4K102J-	1	R CARBON FILM	1/4W 1K OHM J	EA
R13	RD-4K102J-	1	R CARBON FILM	1/4W 1K OHM J	EA
R14	RD-4K102J-	1	R CARBON FILM	1/4W 1K OHM J	EA
R15	RD-4K102J-	1	R CARBON FILM	1/4W 1K OHM J	EA
R16	RD-4K102J-	1	R CARBON FILM	1/4W 1K OHM J	EA
R17	RD-4K102J-	1	R CARBON FILM	1/4W 1K OHM J	EA
R18	RD-4K102J-	1	R CARBON FILM	1/4W 1K OHM J	EA
R19	RD-4K102J-	1	R CARBON FILM	1/4W 1K OHM J	EA
R20	RN-4K6192F	1	R METAL FILM	1/4W 61.9K OHM F	EA
R21	RN-4K1022F	1	R METAL FILM	1/4W 10.2K OHM F	EA
R22	RN-4K1022F	1	R METAL FILM	1/4W 10.2K OHM F	EA
R23	RN-4K4122F	1	R METAL FILM	1/4W 41.2K OHM F	EA
R24	RN-4K4122F	1	R METAL FILM	1/4W 41.2K OHM F	EA
R25	RD-4K102J-	1	R CARBON FILM	1/4W 1K OHM J	EA
R26	RD-4K102J-	1	R CARBON FILM	1/4W 1K OHM J	EA
R27	RD-4K102J-	1	R CARBON FILM	1/4W 1K OHM J	EA
R28	RD-4K102J-	1	R CARBON FILM	1/4W 1K OHM J	EA
R29	RD-4K102J-	1	R CARBON FILM	1/4W 1K OHM J	EA
R30	RD-4K103J-	1	R CARBON FILM	1/4W 10K OHM J	EA
R31	RD-4K331J-	1	R CARBON FILM	1/4W 330 OHM J	EA
R32	RN-4K1272F	1	R METAL FILM	1/4W 12.7K OHM F	EA
R33	RD-4K331J-	1	R CARBON FILM	1/4W 330 OHM J	EA
R34	RN-4K1272F	1	R METAL FILM	1/4W 12.7K OHM F	EA
R35	RD-4K102J-	1	R CARBON FILM	1/4W 1K OHM J	EA
R36	RD-4K562J-	1	R CARBON FILM	1/4W 5.6K OHM J	EA
R37	RD-4K102J-	1	R CARBON FILM	1/4W 1K OHM J	EA
R38	RD-4K103J-	1	R CARBON FILM	1/4W 10K OHM J	EA
R39	RD-4K103J-	1	R CARBON FILM	1/4W 10K OHM J	EA

Location	Part Code	Q'ty	Part Name	Description	Unit
R40	RD-4K103J-	1	R CARBON FILM	1/4W 10K OHM J	EA
R41	RD-4K103J-	1	R CARBON FILM	1/4W 10K OHM J	EA
R42	RD-4K102J-	1	R CARBON FILM	1/4W 1K OHM J	EA
R43	RD-4K103J-	1	R CARBON FILM	1/4W 10K OHM J	EA
R44	RD-4K102J-	1	R CARBON FILM	1/4W 1K OHM J	EA
R45	RD-4K103J-	1	R CARBON FILM	1/4W 10K OHM J	EA
R46	RD-4K103J-	1	R CARBON FILM	1/4W 10K OHM J	EA
CC1	CCXE1H104M	1	C-CERA	104M 50V DC	EA
CC2	CCXE1H104M	1	C-CERA	104M 50V DC	EA
CC3	CCXE1H104M	1	C-CERA	104M 50V DC	EA
CC4	CCXE1H103M	1	C-CERA	103M 50V DC	EA
CC5	CCXE1H104M	1	C-CERA	104M 50V DC	EA
CC6	CCXE1H103M	1	C-CERA	103M 50V DC	EA
CC7	CCXE1H103M	1	C-CERA	103M 50V DC	EA
CC8	CCXE1H103M	1	C-CERA	103M 50V DC	EA
CC9	CCXE1H104M	1	C-CERA	104M 50V DC	EA
CC10	CDXE1H104M	1	C-MULTI	104Z,CRO561B-Z5U	EA
CC11	CCXE1H104M	1	C-CERA	104M 50V DC	EA
CC12	CCXE1H103M	1	C-CERA	103M 50V DC	EA
CC13	CCXE1H103M	1	C-CERA	103M 50V DC	EA
CC14	CCXE1H103M	1	C-CERA	103M 50V DC	EA
CC15	CCXE1H103M	1	C-CERA	103M 50V DC	EA
CC16	CCXE1H103M	1	C-CERA	103M 50V DC	EA
CE1	CEXE1E227C	1	C-ELEC	220uF 25V SD(SG)	EA
CE2	CEXE1E107C	1	C-ELEC	100uF 25V SD(SG)	EA
CE3	CEXE1H106C	1	C-ELEC	10uF 50V SD(SG)	EA
CE4	CEXE1H475C	1	C-ELEC	4.7uF 50V SD(SG)	EA
CE5	CEXE1E476C	1	C-ELEC	47uF 25V SD(SG)	EA
RA1	RA8K5103J-	1	R-ARRAY	6P(5)X 103J	EA
RA2	RA8K3103J-	1	R-ARRAY	4P(3)X 103J	EA
CA1	CN5XD104M-	1	C-ARRAY	6P(F5)X 104Z	EA
CA2	CN3XD104M-	1	C-ARRAY	4P(F3)X 104Z	EA
D1	DZN5408---	1	DIODE	1N5408, 1000V/3.0A	EA
ZD1	DZN5370B--	1	DIODE ZENER	1N5370B, 56V/2.3A	EA
JS1	3109400100	1	JUMPER	10MM	EA
JS3	3109400100	1	JUMPER	10MM	EA
JS5	3109400100	1	JUMPER	10MM	EA
PC1	1LTV817C--	1	IC PHOTOCOUPLER	LTV817C	EA
BZ1	3105698200	1	BUZZER	DP-2520BA, BM-20K	EA
OSC1	5PRT800MG-	1	RESONATOR	RT8.00MG	EA
IC4	1KA78L05F-	1	IC REGULATOR	KA78L05F	EA
IC5	1KA7042P--	1	IC RESET	KIA7042P 5L	EA
TR1	TKRC102M--	1	TR	KRC 102-M	EA
TR2	TZTA1270Y-	1	TR	KTA1270Y	EA
TR3	TKRC102M--	1	TR	KRC 102-M	EA
PCB	3114308320	1	PCB CONTROL	TAS-15H(110*130*1.6T,FR1)	EA
IC1	13GS87PH46	1	IC MICOM	TMP87PH846N	EA
IC2	1L7812CV--	1	IC REGULATOR	7812	EA
IC3	1ULN2004A-	1	IC DRIVER	ULN2004A	EA

## ◆PART LIST OF OUTDOOR PCB (TAS-12,15,18,24HO)

✓ **Caution** : In this Manual, some parts can be changed for improving, their performance without notice in the parts list. So, if you need the latest parts information, please refer to PPL(Parts Price List) in Service Information Center (<http://svc.dwe.co.kr>).

Location	Part Code	Q'ty	Part Name	Description	Unit
CN1	3108802500	1	WAFER	YW396-03AV	EA
CN2	3108803200	1	WAFER	YW396-06V	EA
CN3	3108803600	1	WAFER	YFW800-01D	EA
CN4	3108803500	1	PIN	GP881206-2(250)	EA
CN5	3108803400	1	PIN	GP881205-2(187)	EA
CN6	3108804200	1	WAFER	SMW250-02(RED)	EA
CL1	CLV-B3104M	1	C-LINE ACROSS	275V 104K(PILKOR)	EA
F2	52F2550R2-	1	BEAD FILTER	BFS2550 R2	EA
FUSE	5FVLB4002L	1	FUSE GLASS TUBE	250V/50T 4.0A	EA
CLIP	3107000600	2	FUSE CLIP	AFC-520	EA
VAR	D15G561K--	1	VARISTOR	15G561K/350V, SVC561-14	EA
CE1	CEXE2G686C	1	C-ELEC	68uF 400V SD(SG)	EA
CE2	CEXE1E476C	1	C-ELEC	47uF 25V SD(SG)	EA
CE3	CEXE1H105A	1	C-ELEC	1uF 50V SD(SG)	EA
CE4	CEXE1H477C	1	C-ELEC	470uF 50V RX	EA
CE5	CEXE1H227C	1	C-ELEC	220uF 50V SD(SG)	EA
CE6	CEXE1V337C	1	C-ELEC	330uF 35V RX	EA
CE7	CEXE1V227C	1	C-ELEC	220uF 35V SD(SG)	EA
CE8	CEXE1E227C	1	C-ELEC	220uF 25V SD(SG)	EA
CE9	CEXE1E107C	1	C-ELEC	100uF 25V SD(SG)	EA
CE10	CEXE1H226A	1	C-ELEC	22uF 50V SD(SG)	EA
CE11	CEXE1H475C	1	C-ELEC	4.7uF 50V SD(SG)	EA
CE13	CEXE1E107C	1	C-ELEC	100uF 25V SD(SG)	EA
CE14	CEXE1H106C	1	C-ELEC	10uF 50V SD(SG)	EA
CC1	CH1BBN103K	1	C-CERA	Bn 103K 1KV DC	EA
CC2	CCXE1H104M	1	C-CERA	104M 50V DC	EA
CC3	CCXE1H104M	1	C-CERA	104M 50V DC	EA
CC4	CCXE1H104M	1	C-CERA	104M 50V DC	EA
CC5	CCXE1H104M	1	C-CERA	104M 50V DC	EA
CC6	CCXE1H104M	1	C-CERA	104M 50V DC	EA
CC9	CCXE1H103M	1	C-CERA	103M 50V DC	EA
CC10	CCXE1H103M	1	C-CERA	103M 50V DC	EA
CC12	CCXE1H104M	1	C-CERA	104M 50V DC	EA
CC13	CCXE1H103M	1	C-CERA	103M 50V DC	EA
CM1	CDXE1H104M	1	C-MULTI	104Z,CRO561B-Z5U	EA
R1	RS02Y683J-	1	R METAL OXIDE	68K, 2W	EA
R2	RD-4K105J-	1	R CARBON FILM	1/4W 1M OHM	EA
R3	RD-4K105J-	1	R CARBON FILM	1/4W 1M OHM	EA
R4	RD-4K689J-	1	R CARBON FILM	1/4W 6.8 OHM	EA
R5	RD-4K479J-	1	R CARBON FILM	1/4W 4.7 OHM	EA
R6	RD-4K102J-	1	R CARBON FILM	1/4W 1K OHM J	EA
R7	RD-4K100J-	1	R CARBON FILM	1/4W 10 OHM OHM J	EA
R8	RN-4K1002F	1	R METAL FILM	1/4W 10K OHM F	EA
R9	RN-4K1103F	1	R METAL FILM	1/4W 110K OHM F	EA

Location	Part Code	Q'ty	Part Name	Description	Unit
R10	RD-4K271J-	1	R CARBON FILM	1/4W 270 OHM	EA
R11	RD-2K512J-	1	R CARBON FILM	1/2W 5.1K OHM J	EA
R12	RD-4K153J-	1	R CARBON FILM	1/4W 15K OHM J	EA
R13	RS02Y683J-	1	R CARBON OXIDE	68K, 2W	EA
R14	RD-4K331J-	1	R CARBON FILM	1/4W 330 OHM J	EA
R15	RN-4K1272F	1	R METAL FILM	1/4W 12.7K OHM F	EA
R16	RD-4K102J-	1	R CARBON FILM	1/4W 1K OHM J	EA
R17	RD-4K562J-	1	R CARBON FILM	1/4W 5.6K OHM J	EA
R18	RD-4K102J-	1	R CARBON FILM	1/4W 1K OHM J	EA
R19	RD-4K103J-	1	R CARBON FILM	1/4W 10K OHM J	EA
R20	RD-4K102J-	1	R CARBON FILM	1/4W 1K OHM J	EA
R21	RD-4K103J-	1	R CARBON FILM	1/4W 10K OHM J	EA
R22	RD-4K102J-	1	R CARBON FILM	1/4W 1K OHM J	EA
R23	RD-4K103J-	1	R CARBON FILM	1/4W 10K OHM J	EA
HSIC1	3015700110	1	HEAT SINK	35*20*40mm	EA
HSIC2	3015700110	1	HEAT SINK	35*20*40mm	EA
HSIC3	3105797200	1	HEAT SINK	17*23*22mm	EA
HSD4	3105797220	1	HEAT SINK	17*23*33mm	EA
CY1	CH1BFB222K	1	C CERA	222K,250V,Y1	EA
D3	DZN4148FTB	1	DIODE	1N4148 AUTO 26MM	EA
IC2	1L7815CV--	1	IC REGULATOR	7815	EA
IC4	1K1A431---	1	VOLTAGE STABILIZER	KIA431	EA
D4	DSFA804G--	1	UFR DIODE	SFA804G(200V, 8A)	EA
PC1	1LTV817C--	1	IC PHOTOCOUPLER	LTV817C	EA
F3	52C3R3K000	1	CHOKE CIOL	3.3uH, 2A	EA
F4	52C3R3K000	1	CHOKE CIOL	3.3uH, 2A	EA
BD1	DKBJ408G--	1	BRIDGE DIODE	KBJ408G(4A, 800V)	EA
D1	D15KE200A-	1	TVS DIODE	P15KE200A(190V~210V)	EA
D2	DUF1007---	1	UFR DIODE	UF1007(1000V, 1A)	EA
D5	DUF2003---	1	UFR DIODE	UF2003(200V,2A)	EA
TRS1	5EMU2834A-	1	TRANS SMPS	265U, EER2843	EA
F1	52F153K002	1	FILTER LINE	SQE2424,15mH, 2A	EA
IC7	1KA7042P--	1	IC RESET	KIA7042P 5L	EA
IC8	1KA78L05F-	1	IC REGULATOR	KA78L05F	EA
TR1	TKRC102M--	1	TR	KRC 102-M	EA
TR2	TZTA1270Y-	1	TR	KTA1270Y	EA
PCB	3114308520	1	PCB	TAS(100 X 190 X 1.6T FRA)	EA
OSC1	5PRT800MG-	1	RESONATOR	RT8.00MG	EA
RL1	5SC010141B	1	SW RELAY	PCF-112D 1M	EA
RL3	5SC0101310	1	RELAY	US11-12S	EA
RL4	5SC0101310	1	RELAY	US11-12S	EA
RL5	5SC0101310	1	RELAY	US11-12S	EA
IC3	1L7812CV--	1	IC REGULATOR	L7812CV	EA
IC5	13GS87P809	1	IC MICOM	TMP87P809N	EA
IC6	13GT62004A	1	IC DRIVER	ULN2004A	EA
IC1	1TP247YGX-	1	IC SWITCHING	TOP247Y	EA

## Power Supply(1)

### DESCRIPTION

The DC power is SMPS power source. DC Power Supply in circuit needs 30V, 15V and 12V. +12V is used for Compressor Driving Relay, Buzzer Driving Swing and Swing Motor. DC 30V is used for Indoor Fan Motor Power and DC 15V(Vc) is used for Motor Drive. (Refer to PCB Circuit Diagram : Outdoor Unit)

## Oscillator(2)

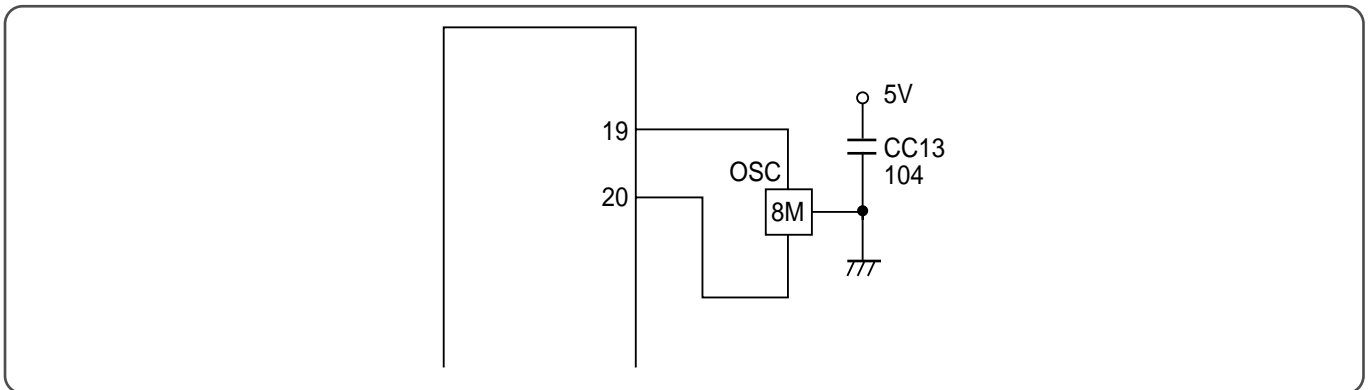

### DESCRIPTION

Oscillatory Frequency drive Micom, it is made up 8MHz resonator oscillatory Frequency. Oscillatory wave is as following Fig 2-1.

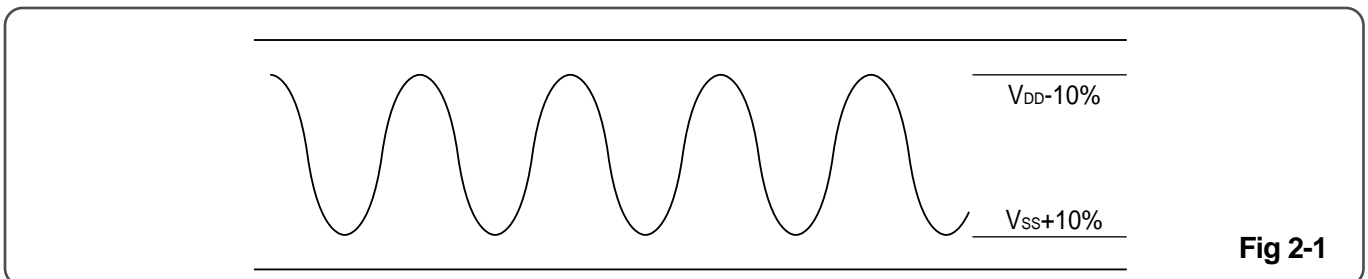

## Sensor(3)

Room temperature and Evaporator temperature Sensor Input

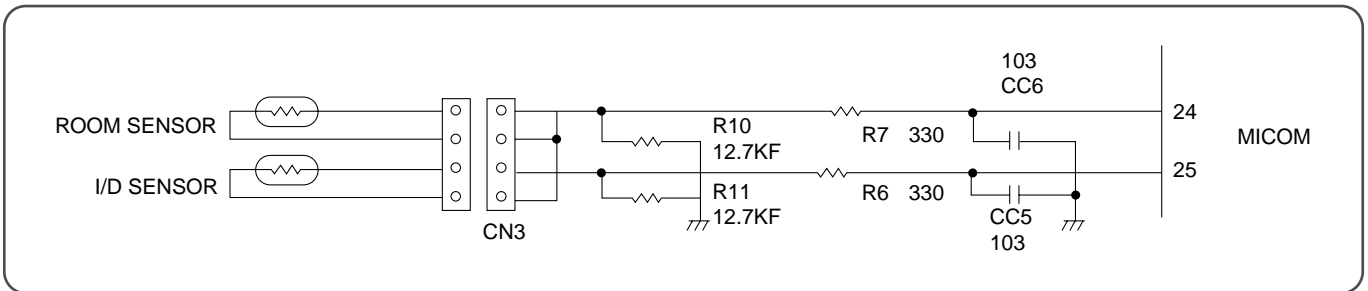

### DESCRIPTION

Number 24, 25 of Micom is Terminal of A/D convertor Input.

Room temperature and Evaporator temperature is sensing by change of Thermister Resistance, Micom is put in 5V by ratio between R10 (12.7KΩ) and R11 (12.7KΩ).

Relation between temperature and voltage is following Table 3-1.

CC5, 6 is Noise filter.

Temperature (°C)	Voltage (V)	
	No. 1	No. 3
-5	1.127	1.127
0	1.378	1.378
5	1.650	1.650
10	1.936	1.936
15	2.228	2.228

Table 3-1

## Indoor Fan Motor Control(4)

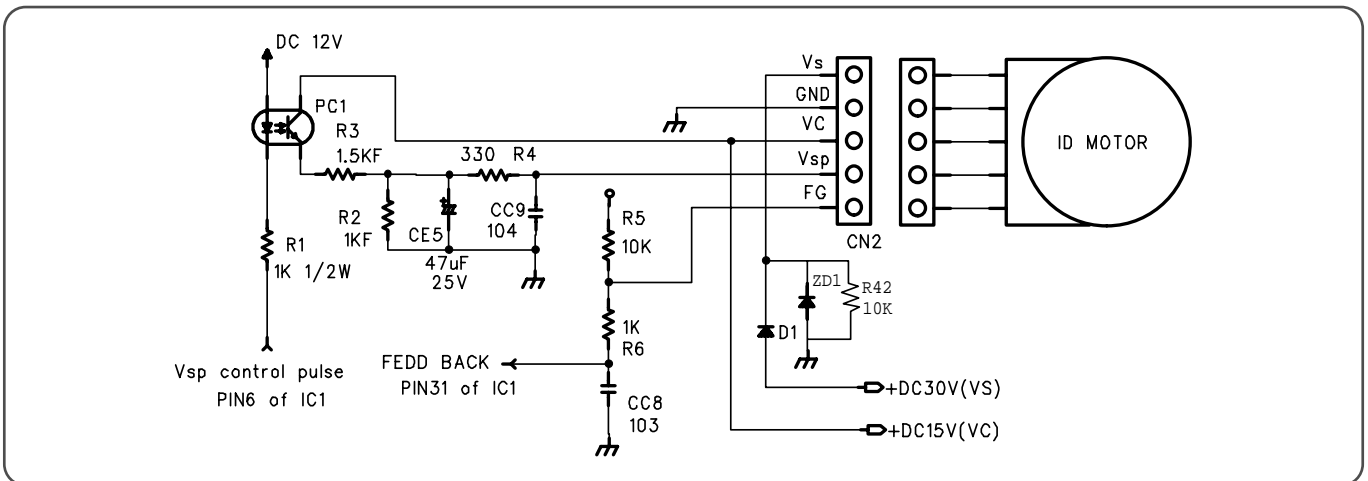

### DESCRIPTION

Indoor Fan motor power is DC30V(Vs)

Indoor Fan motor RPM is controled by Vsp(0~5V)

Vsp control pulse OUTPUT is Pin6, IC1

PIN31 is Indoor Fan motor RPM feed back input.

## Remote Controller(5)

### DESCRIPTION

Signal from Remote Controller put in only Control Data Signal at Micom Terminal of Number 33, which is gotten from Carrier (38KHz) from Receive Module. Signal Wave repeat third as following Fig 5-1. But in Secondary Wave Custom Code is Reversed Face.

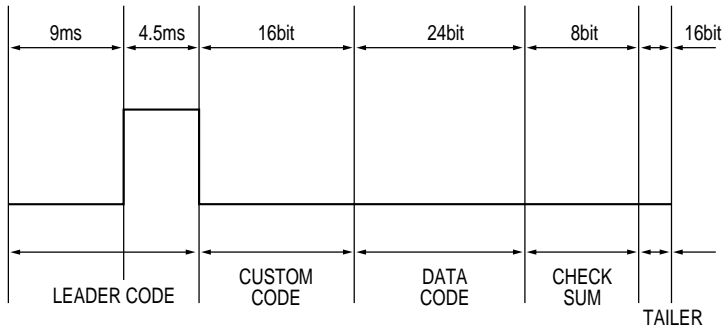

Fig 5-1

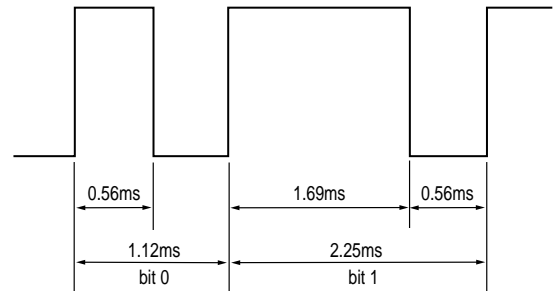
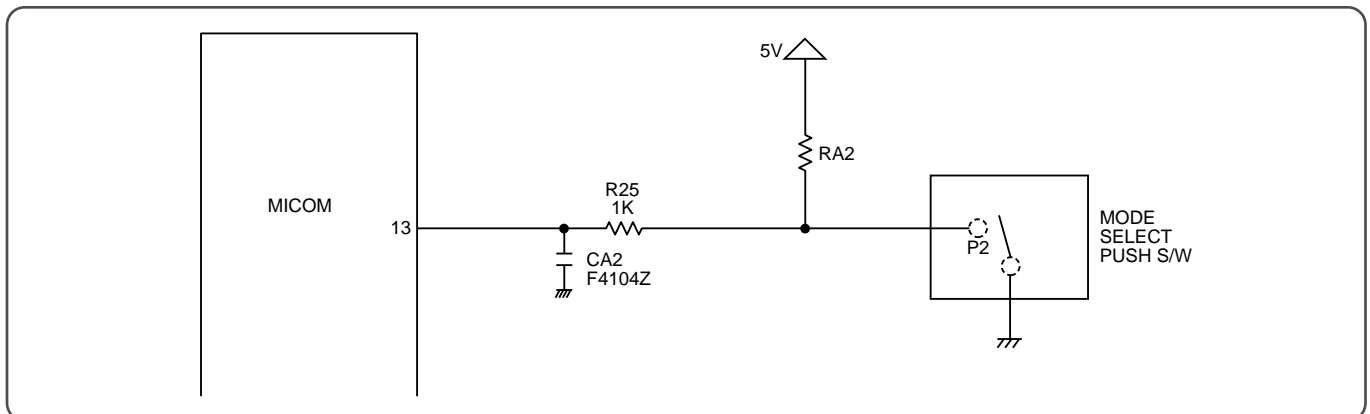

Fig 5-2  
BIT STRUCTURE

## Selecting Mode(6)

(SELECT S/W INPUT, OUTPUT)



### DESCRIPTION

There are Mode according to SW position as following Table 6-1. According as port of fixed Micom is Low, the unit is operating as following Table 6-1.

POSITION	MODE
OPEN	REMOCON
GND	EMERGENCY

Table 6-1

## Micom Power Supply(7)

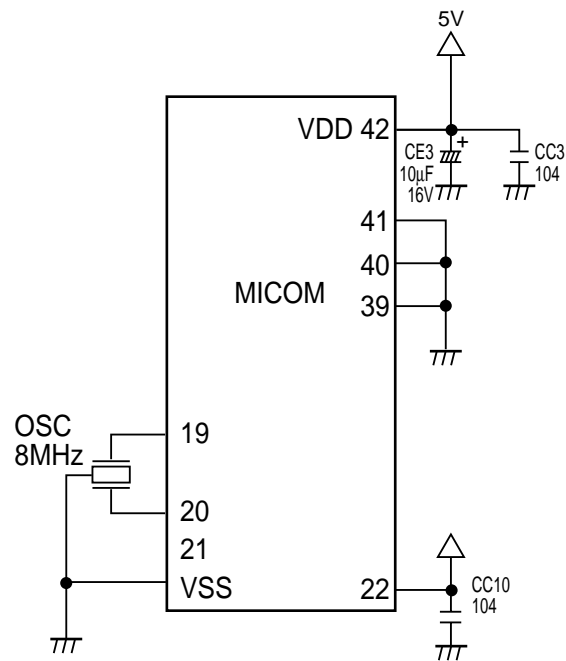

### DESCRIPTION

MICOM Power is supplied 5V at Number 42 using VDD, Number 19, 20 Using Oscillator, CC10 is noise filter.

## Reset(8)

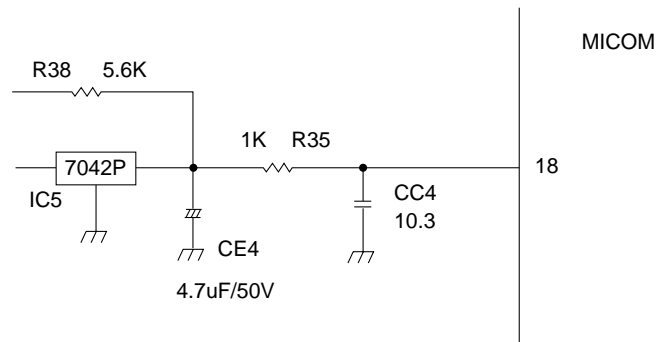

### DESCRIPTION

Voltage less than about 0.8V put in Micom Terminal of Number 18 and then Micom reset. Reset IC detect Power ON and Voltage less than 4.25V, and then send Reset Signal.

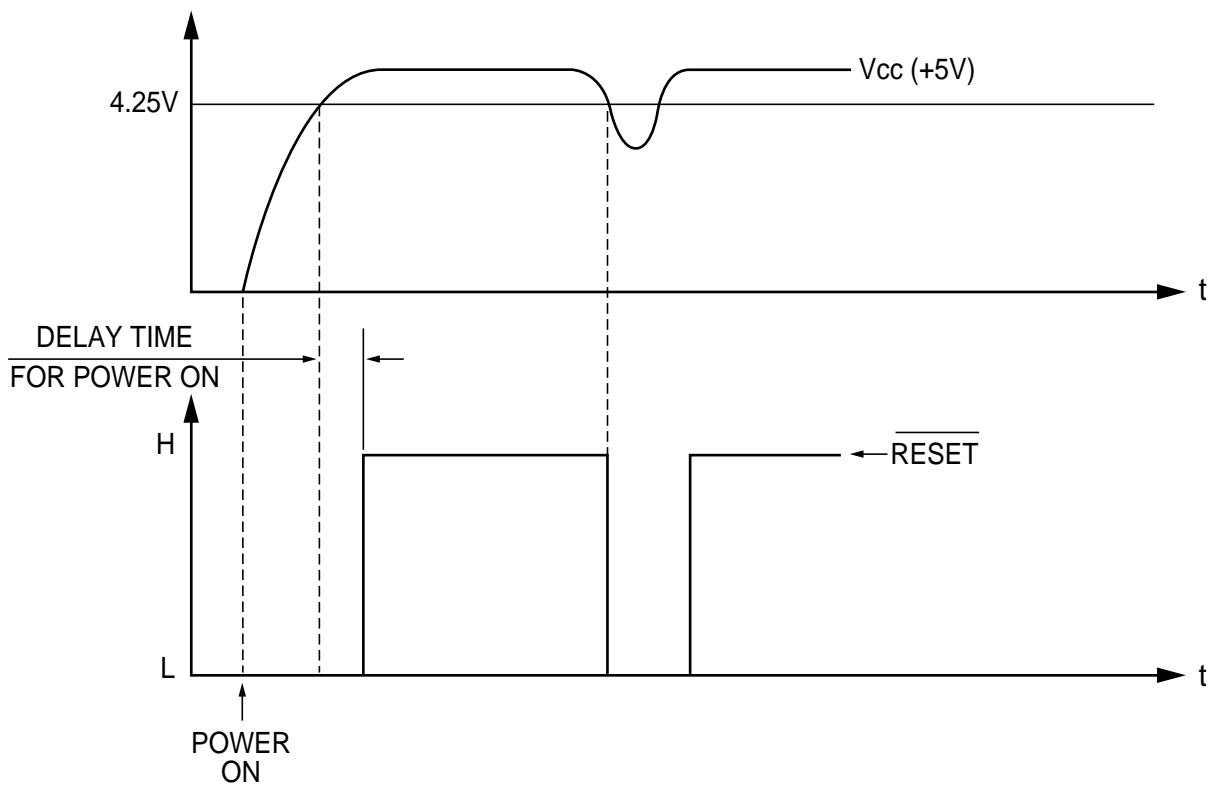

# Function Selecting(9)

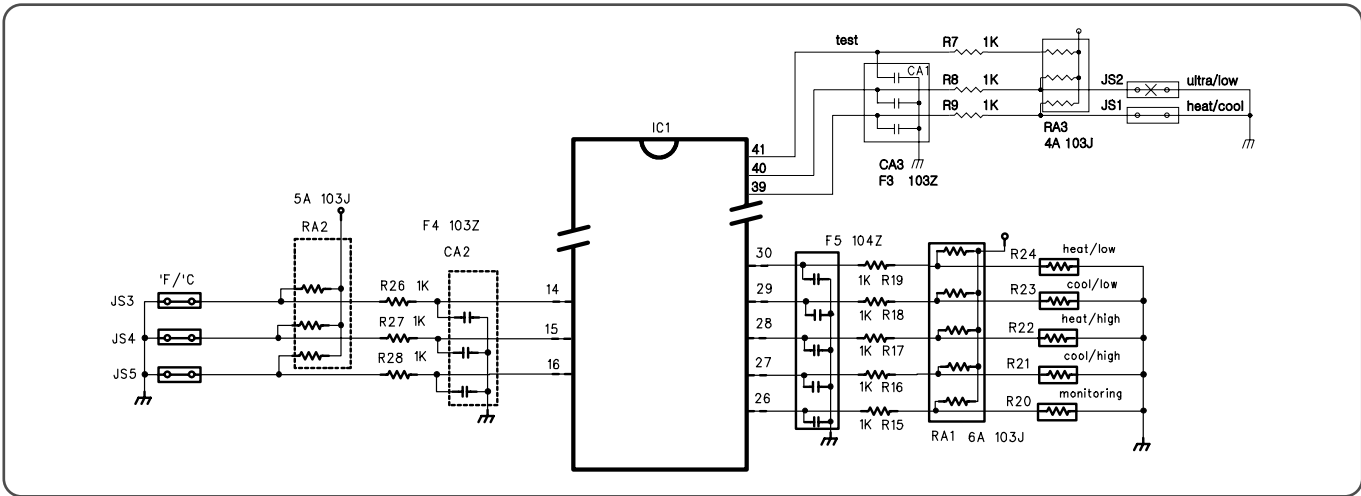

## DESCRIPTION

\* When power source is put at first, Function selection input is recognized. And when the unit is running the microcomputer ignore variation of function selection input.

PIN No.	LOC	JUMPER OPTION		15H	12H/18H/24H
		SHORT	OPEN		
14	JS3	F	°C	O	O
15	JS2	Sleep(ultra low)	Sleep(low)	X	X
16	JS1	Cool/Heat	Cool only	O	O
40	JS5	New Flap Angle	Old Flap angle	O	X
39	JS4	Heat Turbo(O)	Heat Turbo(X)	X	X

• R20~R24: Indoot Fan Motor RPM select option with A/D signal.

# Buzzer Driving(10)

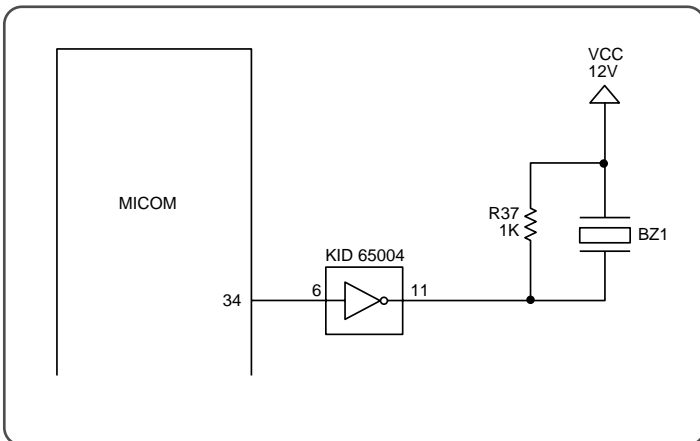

## DESCRIPTION

Micom 34 Terminal put out Buzzer Driving Pulse, its output is driving Buzzer through Buffer. Oscillatory Frequency of buzzer is selected by internal Micom. This unit is setting at 4KHz.

# Stepping Motor Driving(12)

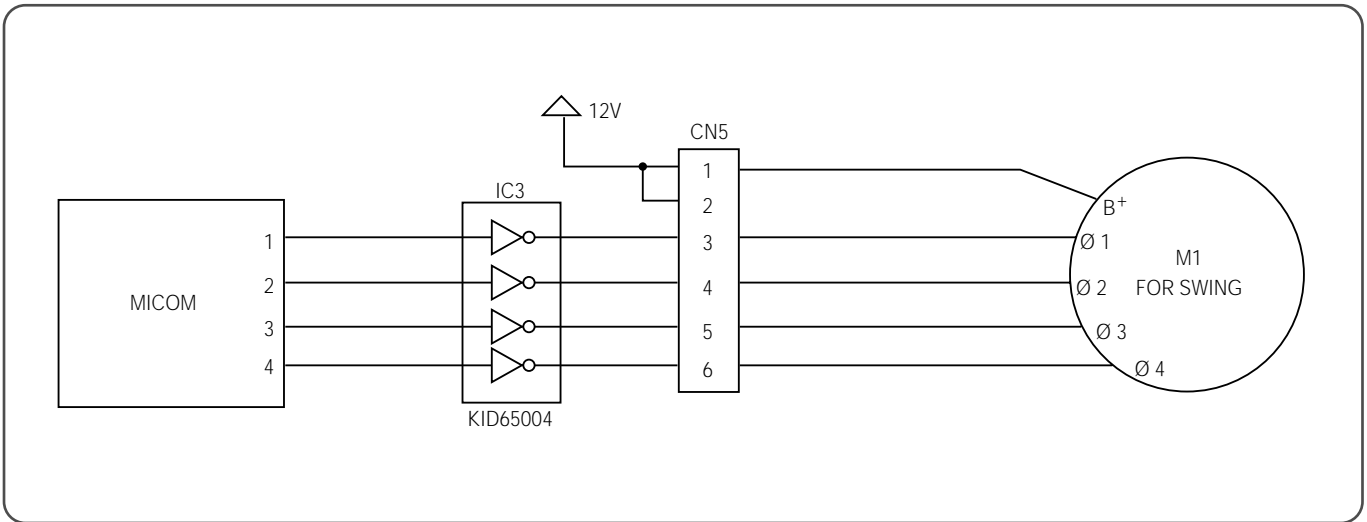

## DESCRIPTION

There are one Stepping Motor for Flap (up and down) and it is used 4 face Drive Method. It is driving as following Fig 12-1. (Ring Count Method of 8 Status)

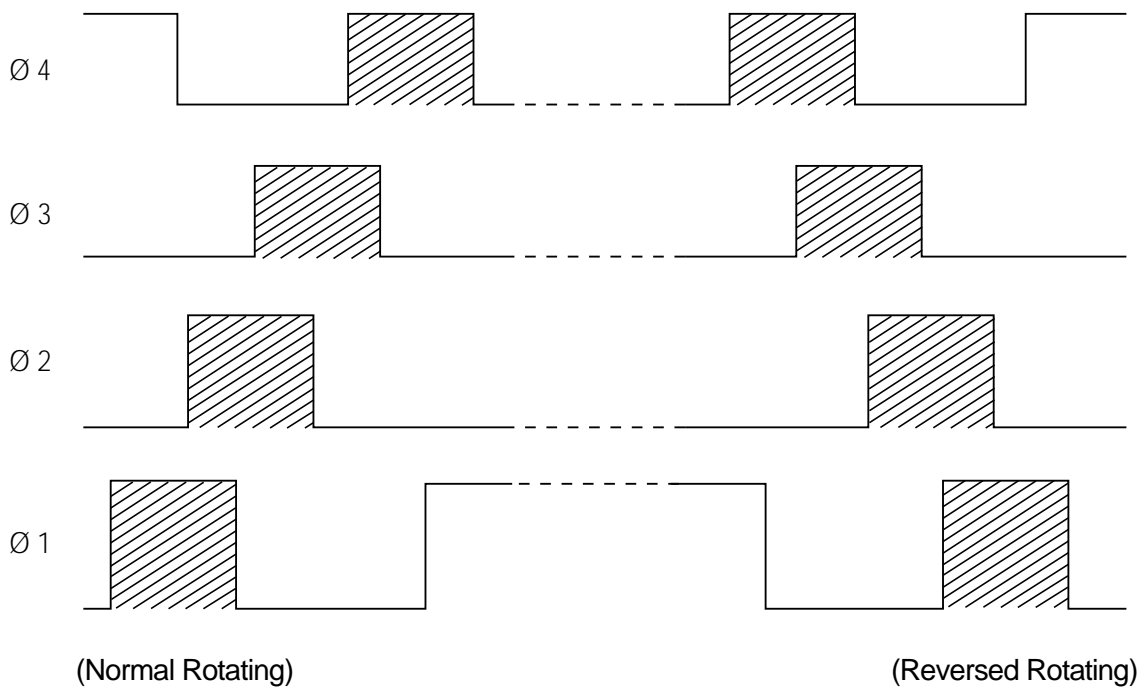
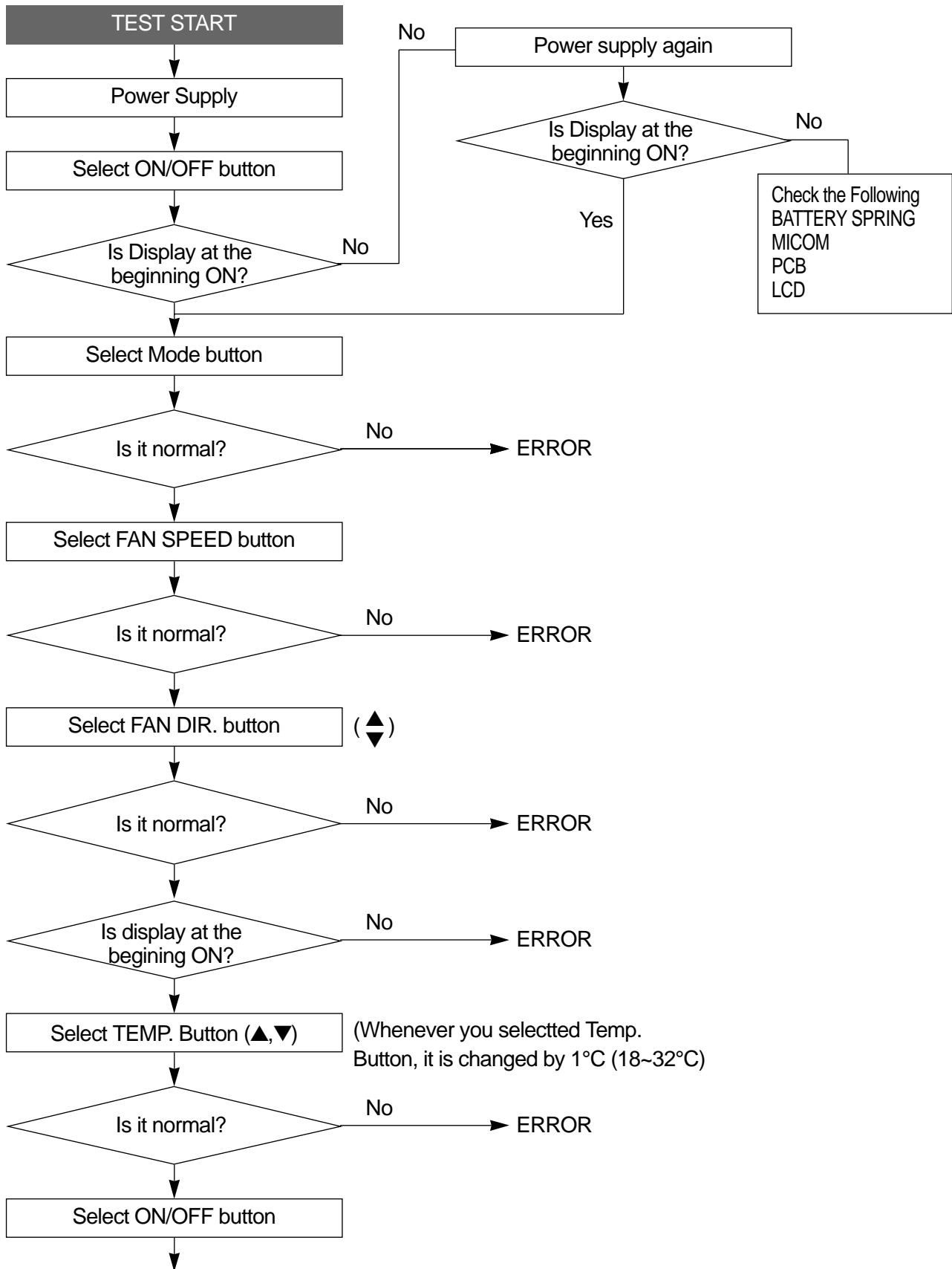
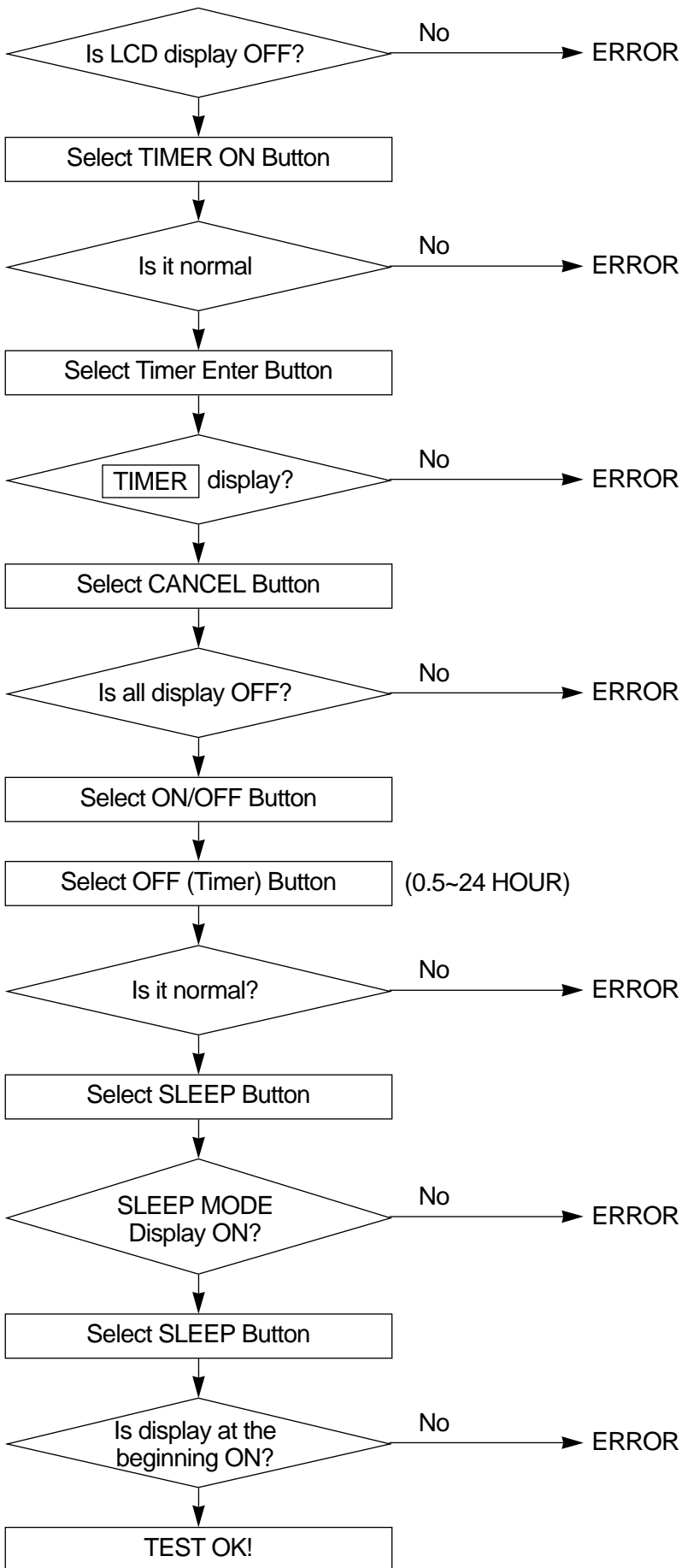

Fig 12-1

# • REMOTE CONTROLLER ASSMBLY FUNCTIONAL TEST METHOD





# 8. KEY COMPONENTS OF ELECTRONIC CIRCUIT

## (1) U1 (MICOM)

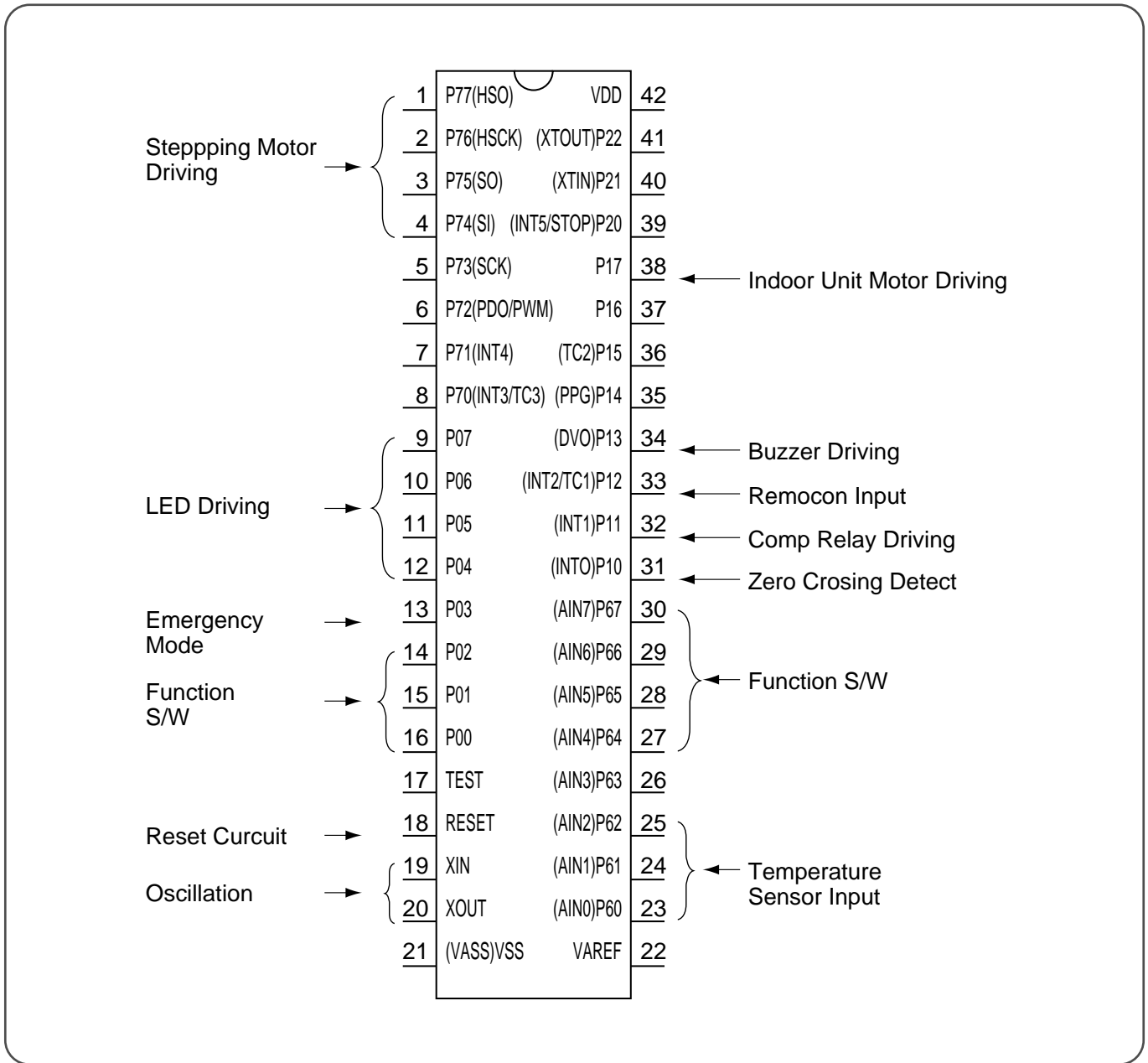

## (2) U2, 4 (KID65004) DARLINGTON ARRAYS

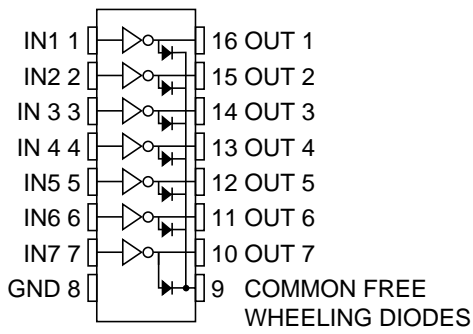

(Top View)

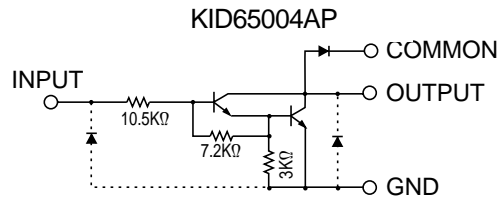

(Equivalent Circuit)

## (3) U8 (KIA7805P) : VOLTAGE REGULATOR (5VDC)

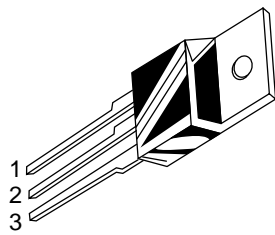

Pin 1. INPUT  
2. GROUND  
3. OUTPUT

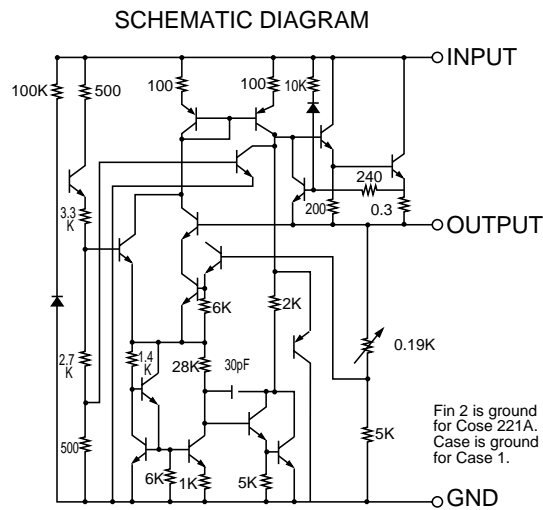

Fin 2 is ground for Case 221A. Case is ground for Case 1.

## (4) U7 (KIA7812P) : VOLTAGE REGULATOR (12VDC)

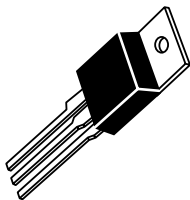

Pin 1. INPUT  
2. GROUND  
3. OUTPUT

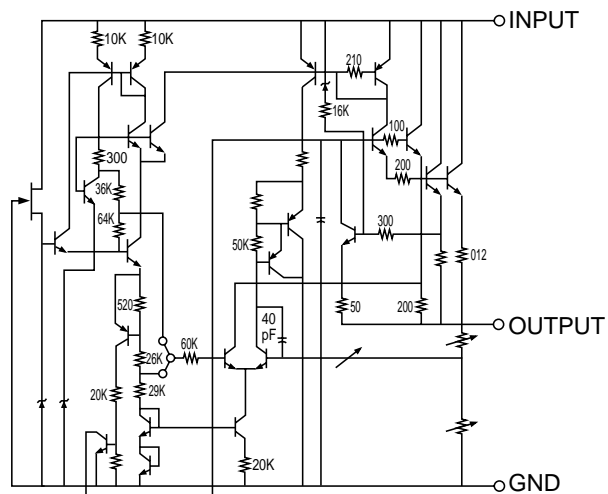

(Equivalent Ciircuit)

## (5) U9 (KIA7042P) : RESET IC

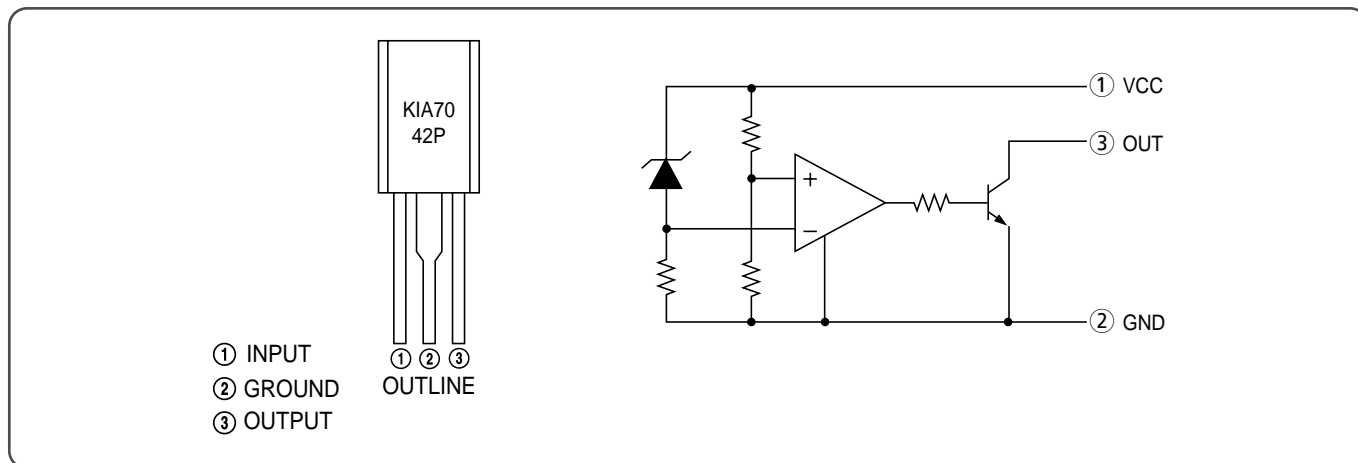

# 9. DISASSEMBLY INSTRUCTIONS

## 1 INDOOR UNIT

### ◆TAS-12H

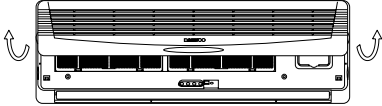
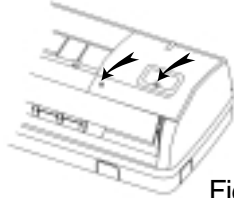
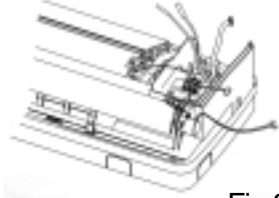
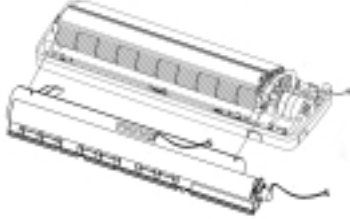
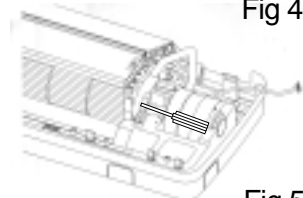
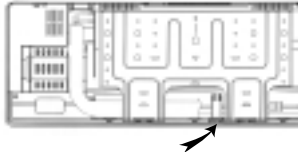
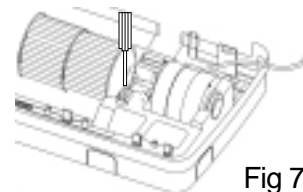
PROCEDURES	PHOTOS
<p>1. Stop the Air conditioner and disconnect the power cord from the wall outlet.</p>	
<p>2. Removing the Insert Grille and Frame Grille. (Fig 1~2)</p> <ol style="list-style-type: none"> <li>① Draw up the Insert Grille and remove it.</li> <li>② Loosen one screw for fixing the Cover Ter-Block.</li> <li>③ Loosen two screw at the Frame Grille.</li> <li>④ Remove the Frame Grille.</li> </ol>	<p>Fig 1</p>  <p>Fig 2</p>
<p>3. Removing the Control Box. (Fig 3)</p> <ol style="list-style-type: none"> <li>① Remove room and coil thermistors.</li> <li>② Disconnect the fan motor lead wire from connection at the Control PCB.</li> <li>③ Disconnect the stepping motor lead wire from connection at the Control PCB.</li> <li>④ Remove the select switch from connection at the Control PCB.</li> <li>⑤ Loosen a screw for fixing ground wire.</li> <li>⑥ Remove the Control Box</li> </ol>	 <p>Fig 3</p> 
<p>4. Removing the Drain Pan. (Fig 4)</p> <ol style="list-style-type: none"> <li>① Disconnect the Body drain hole. (left and right Body)</li> <li>② Disconnect three hook and remove the Drain Pan.</li> </ol>	<p>Fig 4</p>  <p>Fig 5</p>
<p>5. Removing the Indoor Evaporator. (Fig 5~6)</p> <ol style="list-style-type: none"> <li>① Remove one screw for fixing indoor Evaporator at the Body.</li> <li>② Remove the hook for fixing Bracket Pipe at the back of Body.</li> <li>③ Remove Indoor Evaporator.</li> </ol>	 <p>Fig 6</p>
<p>6. Removing the Cross Flow Fan. (Fig 7)</p> <ol style="list-style-type: none"> <li>① Remove set screw for fixing Motor shaft.</li> <li>② Remove Cross Flow Fan.</li> </ol>	 <p>Fig 7</p>
<p>7. Remove Motor IDU and Bearing Plastic.</p>	

## ◆TAS-15H

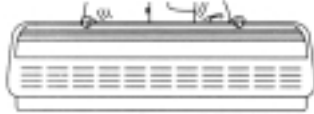
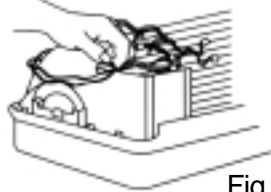
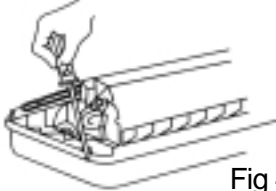
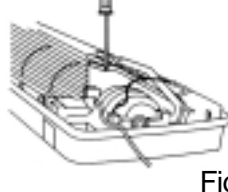
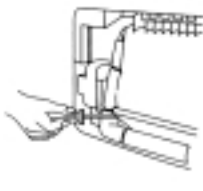
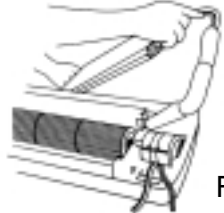
PROCEDURES	PHOTOS
<p>1. Stop the Air conditioner and disconnect the power cord from the wall outlet.</p>	
<p>2. Removing the Insert Grille and Frame.</p> <p>① Loosen three screws for fixing the the Insert Grille and Frame. (Pull out the frame cap before loosening three screws) (Fig 1)</p> <p>② Loosen three screws at the Drain Pan.</p> <p>③ Remove the Insert Grille and Frame.</p>	<p>Fig 1</p> 
<p>3. Removing the Control Box.</p> <p>After doing above procedures:</p> <p>① Disconnect indoor room and coil thermistors. (Fig 3)</p> <p>② Disconnect the fan motor lead wire from connection at the main PCB. (Fig 3)</p> <p>③ Disconnect the swing motor connection wire.</p> <p>④ Loosen a screw for fixing ground wire.</p> <p>⑤ Loosen two screws for fixing the body.</p>	<p>Fig 2</p> 
<p>4. Removing the Drain Pan.</p> <p>After doing above procedures:</p> <p>① Loosen a screw for fixing body. (Fig 4)</p> <p>② Unhook the right part of Drain Pan.</p>	<p>Fig 3</p> 
<p>5. Removing the Indoor Coil.</p> <p>After doing above procedures:</p> <p>① Loosen four screws for fixing indoor coil at left and right side. (Fig 5)</p> <p>② Loosen a screw for fixing the bracket tube at the back side. (Fig 6)</p> <p>③ Remove the indoor coil. (Fig. 6-1)</p>	<p>Fig 4</p> 
<p>6. Removing the fan motor.</p> <p>After doing above procedures:</p> <p>① Loosen two screws for fixing holder moter at left and right side. (Fig 7, 8)</p> <p>② Loosen a screw for fixing fan motor and blower.</p> <p>③ Remove the fan motor.</p>	<p>Fig 5</p> 
<p>① Loosen two screws for fixing holder moter at left and right side. (Fig 7, 8)</p> <p>② Loosen a screw for fixing fan motor and blower.</p> <p>③ Remove the fan motor.</p>	<p>Fig 6</p>  <p>Fig 6-1</p>

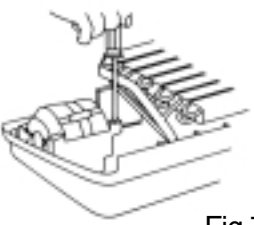
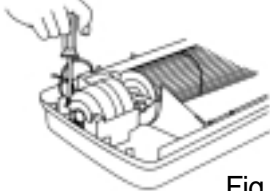
PROCEDURES	PHOTOS
<p>7. Removing the blower.</p> <p>After doing above procedures:</p> <ul style="list-style-type: none"><li>① Loosen a screw for fixing holder bearing.</li><li>② Remove the blower.</li></ul>	 <p>Fig 7</p>  <p>Fig 8</p>

◆TAS-18/24H

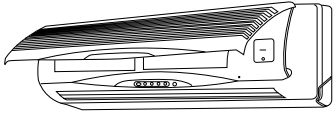
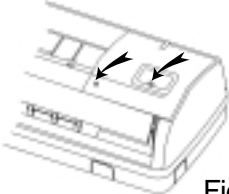
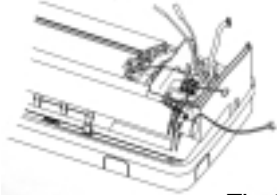
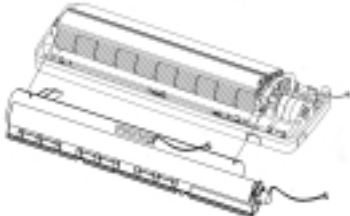
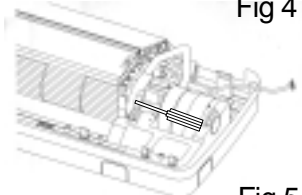
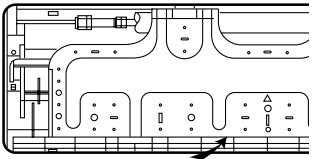
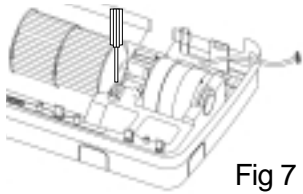
PROCEDURES	PHOTOS
<p>1. Stop the operation of the Air conditioner and disconnect the power cord from the wall outlet.</p>	 <p>Fig 1</p>
<p>2. Removing the Insert Grille and Frame Grille. (Fig 1~2)</p> <p>① Draw up the Insert Grille and remove it.</p> <p>② Loosen the screws fixed at the Cover Ter-Block.</p> <p>③ Loosen two screw at the Frame Grille.</p> <p>④ Remove the Frame Grille.</p>	 <p>Fig 2</p>
<p>3. Removing the Control Box. (Fig 3)</p> <p>① Remove room and coil thermistors.</p> <p>② Disconnect the fan motor lead wire from connection at the Control PCB.</p> <p>③ Disconnect the stepping motor lead wire from connection at the Control PCB.</p> <p>④ Remove the select switch from connection at the Control PCB.</p> <p>⑤ Loosen the screw fixed at the ground wire.</p> <p>⑥ Remove the Control Box</p>	 <p>Fig 3</p>
<p>4. Removing the Drain Pan. (Fig 4)</p> <p>① Disconnect the Body drain hole. (left and right Body)</p> <p>② Disconnect three hooks and remove the Drain Pan.</p>	 <p>Fig 4</p>
<p>5. Removing the Indoor Evaporator. (Fig 5~6)</p> <p>① Remove the hook fixed at the Plate mounting of the back of Body.</p> <p>② Remove Indoor Evaporator.</p>	 <p>Fig 5</p>
<p>6. Removing the Cross Flow Fan. (Fig 7)</p> <p>① Remove the set screw fixed at the Motor shaft.</p> <p>② Remove the Cross Flow Fan.</p>	 <p>Fig 6</p>
<p>7. Remove the Motor IDU and the Bearing Plastic.</p>	 <p>Fig 7</p>

## 2 OUTDOOR UNIT

### ◆TAS-12/15/18HO

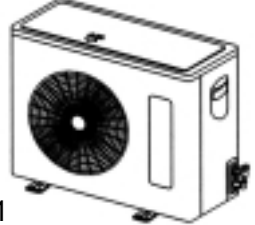
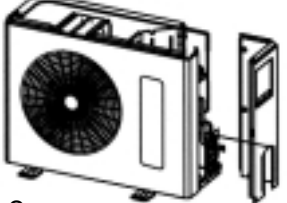
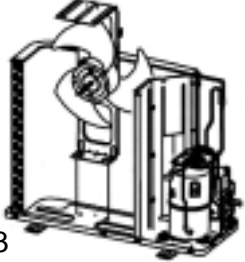
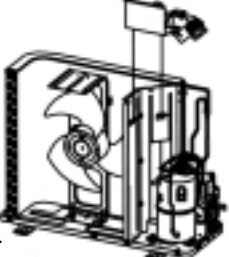
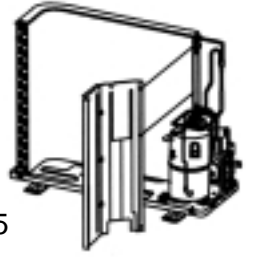
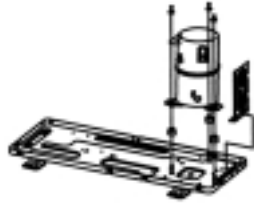
PROCEDURES	PHOTOS
<p>1. Stop the operation of the air conditioner and disconnect the wire from indoor unit to outdoor unit.</p>	 <p>Fig 1</p>
<p>2. Disassemble the case. (Fig 1~2)</p> <ol style="list-style-type: none"><li>① Remove the Top Panel.</li><li>② Remove the Side Cabinet.</li><li>③ Remove the Front Cabinet.</li></ol>	 <p>Fig 2</p>
<p>3. Removing the Propeller Fan. (Fig 3)</p> <ol style="list-style-type: none"><li>① Loosen the screw fixed at the motor bracket.</li><li>② Remove the Plain Washer.</li><li>③ Remove the Propeller Fan.</li></ol>	 <p>Fig 3</p>
<p>4. Remove the panel control. (Fig 4)</p> <ol style="list-style-type: none"><li>① Disconnect the wire at the control panel.</li><li>② Loosen the screw fixed at the panel control.</li><li>③ Remove the parts on panel control.</li></ol>	 <p>Fig 4</p>
<p>5. Remove the partition panel. (Fig 5)</p> <ol style="list-style-type: none"><li>① Loosen four screws at the bracket motor.</li><li>② Disconnect the wire at the control panel.</li></ol>	 <p>Fig 5</p>
<p>6. Removing the Over load Protector. (Fig 6)</p> <ol style="list-style-type: none"><li>① Remove the cocondenser</li><li>② Loosen three volts at compressor.</li><li>③ Remove the compressor.</li></ol>	 <p>Fig 6</p>

## ◆TAS-24HO

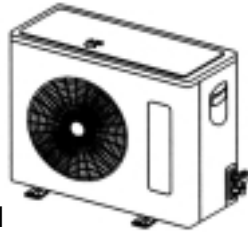
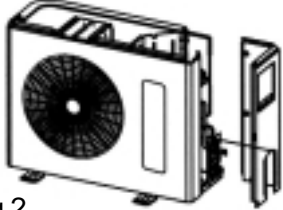
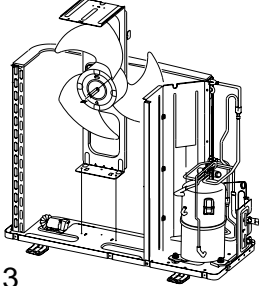
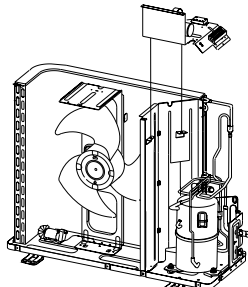
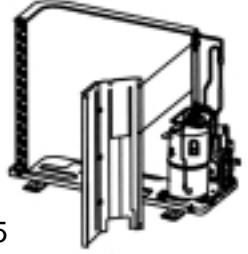
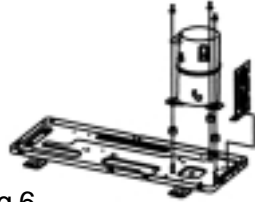
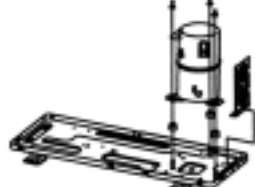
PROCEDURES	PHOTOS
<p>1. Stop the operation of the air conditioner and disconnect the wire from in door unit to out door unit.</p>	 <p>Fig 1</p>
<p>2. Disassemble the case. (Fig 1~2)</p> <ol style="list-style-type: none"> <li>① Remove the Top Panel.</li> <li>② Remove the Front Cabinet.</li> <li>③ Remove the Side Cabinet and Back Cabinet.</li> </ol>	 <p>Fig 2</p>
<p>3. Removing the Propeller Fan. (Fig 3)</p> <ol style="list-style-type: none"> <li>① Loosen the screw fixed at the motor bracket.</li> <li>② Remove the Plain Washer.</li> <li>③ Remove the Propeller Fan.</li> </ol>	 <p>Fig 3</p>
<p>4. Removing the panel control. (Fig 4)</p> <ol style="list-style-type: none"> <li>① Disconnect the wire at the control panel.</li> <li>② Loosen the screw at the panel control.</li> <li>③ Remove the parts on the panel control.</li> </ol>	 <p>Fig 4</p>
<p>5. Removing the vaccum pump.</p>	 <p>Fig 5</p>
<p>6. Remove the partition panel. (Fig 5)</p> <ol style="list-style-type: none"> <li>① Loosen four screws at the bracket motor.</li> <li>② Disconnect the wire at the control panel.</li> </ol>	 <p>Fig 6</p>
<p>7. Removing the Over load Protector. (Fig 6)</p> <ol style="list-style-type: none"> <li>① Remove the cocondenser</li> <li>② Loosen three volts at the compressor.</li> <li>③ Remove the compressor.</li> </ol>	 <p>Fig 6</p>

# 10. EXPLODED VIEW AND PART LIST

## 1 INDOOR UNIT

◆TAS-12H

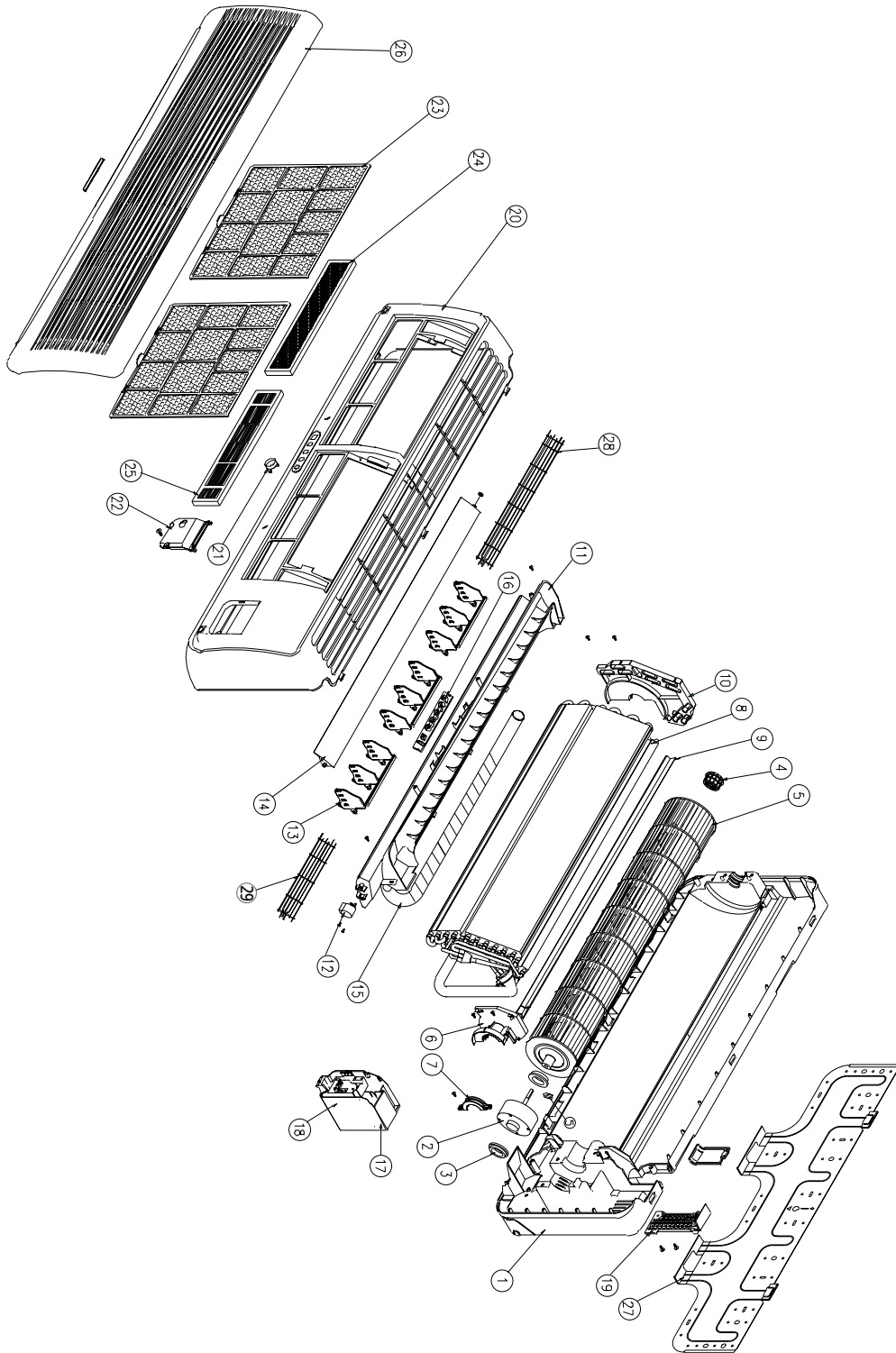

## ◆Indoor Unit Part List (TAS-12H)

✓ **Caution** : In this Manual, some parts can be changed for improving, their performance without notice in the parts list. So, if you need the latest parts information, please refer to PPL(Parts Price List) in Service Information Center (<http://svc.dwe.co.kr>).

No	PART CODE	PART NAME	Q'TY	SPEC	REMARK
1	3110058500	BODY Ass`y	1	HIPS T2.0 (GY258A)	
2	3118008200	MOTOR IDU	1	FDA3530DWA	
3	3111503800	CUSHION MOTOR	2	CR	
4	3106400400	BEARING PLASTIC Ass`y	1		
5	3110046000	CFF Ass`y	1	SAN+G.F.30% *100.0xL615	
6	3113000400	HOLDER MOTOR L	1	HIPS T2.0	
7	3113000500	HOLDER MOTOR R	1	HIPS T2.0	
8	3110054100	EVAPORATOR Ass`y	1	3R-3C (FP=1.5)	
9	3112500900	GUIDE EVAP.	1	PVC	
10	3114503300	PLATE EVAP. L	1	PP T2.0(GY176A)	
11	3110059500	PAN DRAIN Ass`y	1	HIPS T2.0 (GY258A)	
12	3108003910	MOTOR STEPPING	1	MP24GA	
13	3116501001	BLADE VERTICAL	3	P.P. T1.5 (GY176A)	
14	3117600101	FLAP	1	HIPS T2.5 (GY171A)	
15	3103210010	DRAIN HOSE Ass'y	1		
16	3104301700	LED PCB Ass'y	1		
17	3110063620	CONTROL BOX Ass`y	1	HIPS(T2.0 BLACK)	
18	3114208610	CONTROL PCB Ass'y	1		
19	3110400200	BODY TOP	1	HIPS T2.0	
20	3110063700	FRAME GRILLE Ass`y	1	HIPS T2.5	
21	3103401400	KNOB SWITCH	1		
22	3111403400	COVER T/BLOCK	1	HIPS T2.0	
23	3111901400	FILTER FRAME	2	P.P. T2.0 (BLACK)	
24	3101902510	FILTER CARBON Ass`y	1	BLACK	
25	3101902610	FILTER ELECTRO Ass`y	1	WHITE	
26	3110063800	INSERT GRILLE Ass`y	1	HIPS T2.5 (GY171A)	
27	3114503800	PLATE MOUNTING	1	SGCC	
28	3112501410	GUIDE SAFETY - A	1	SUS 304 ø1.5	
29	3112501420	GUIDE SAFETY - B	1	SUS 304 ø1.5	

◆TAS-15H

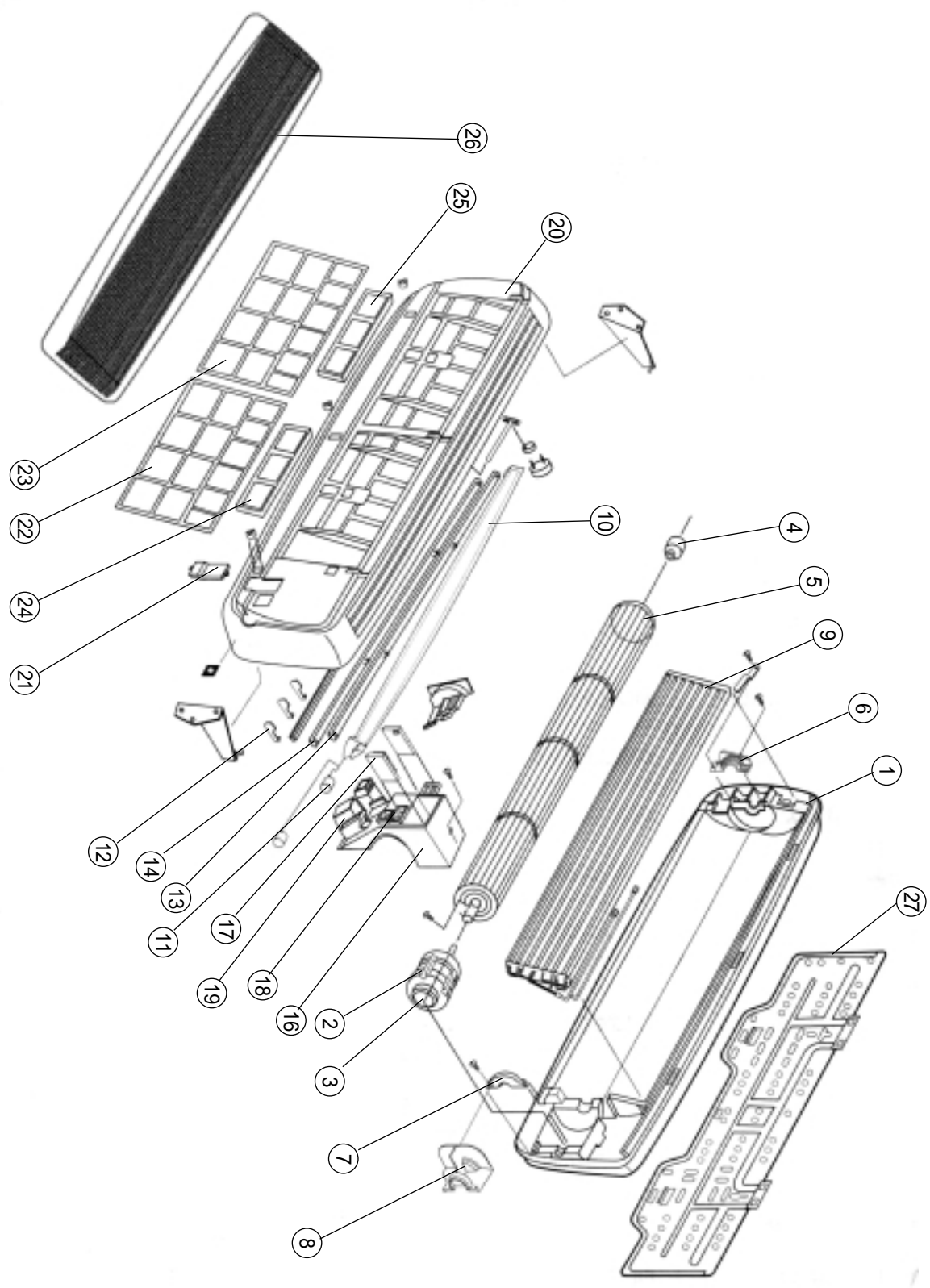

## ◆Indoor Unit Part List (TAS-15H)

✓ **Caution** : In this Manual, some parts can be changed for improving, their performance without notice in the parts list. So, if you need the latest parts information, please refer to PPL(Parts Price List) in Service Information Center (<http://svc.dwe.co.kr>).

No	PART CODE	PART NAME	Q'TY	SPEC	REMARK
1	3100410000	BODY Ass`y	1	HIPS (GY177A)	
2	3118008210	MOTOR IDU	1	FDA3530DWB	
3	3111503800	CUSHION MOTOR	2	CR	
4	3106400100	BEARING PLASTIC	1	RUBBER I.D.ø6.0	
5	3101800200	CFF Ass`y	1	O.D.ø102xL861	
6	3103000700	HOLDER BEARING	1	ABS (BLK)	
7	3103000600	HOLDER MOTOR L	1	ABS (BLK)	
8	3110606600	BRACKET MOTOR	1	HIPS	
9	3107400010	EVAPORATOR Ass`y	1	Fp=1.4	
10	3108120020	PAN DRAIN Ass`y	1	HIPS (GY171A)	
11	3108004300	STEPPING MOTOR	2	DC12V 400mm	
12	3106500401	BLADE VERTICAL	16	PP (GY171A)	
13	3107600100	FLAP TOP	1	ABS (GY171A)	
14	3107600200	FLAP UNDER	1	ABS (GY171A)	
15	3103210010	DRAIN HOSE Ass`y	1	P.P. + INSULATOR	
16	3100005270	CONTROL BOX Ass`y	1		
17	3114308700	CONTROL PCB Ass'y	1		
18	3104300301	SWITCH PCB Ass'y	1		
19	3104300401	LED PCB Ass'y	1		
20	3102210020	FRAME GRILLE Ass`y	1	ABS (GY171A)	
21	3101403700	COVER T/BLOCK	1	ABS (GY171A)	
22	310191000C	FILTER PRE R Ass'y	1	P.P. BLACK	
23	310192000C	FILTER PRE L Ass'y	1	P.P. BLACK	
24	3101930000	FILTER ELECTRO Ass`y	1	WHITE	
25	3101940000	FILTER CARBON Ass`y	1	BLACK	
26	3110017600	INSERT GRILLE Ass`y	1	HIPS (GY171A)	
27	3104500300	PLATE MOUNTING	1	SGCC T0.8	
28	3106300500	BAR DRAIN	2	SUS 304 ø1.5	
29	3100601400	BRACKET DRAIN	1	SUS 304 T1.0	

◆TAS-18, 24H

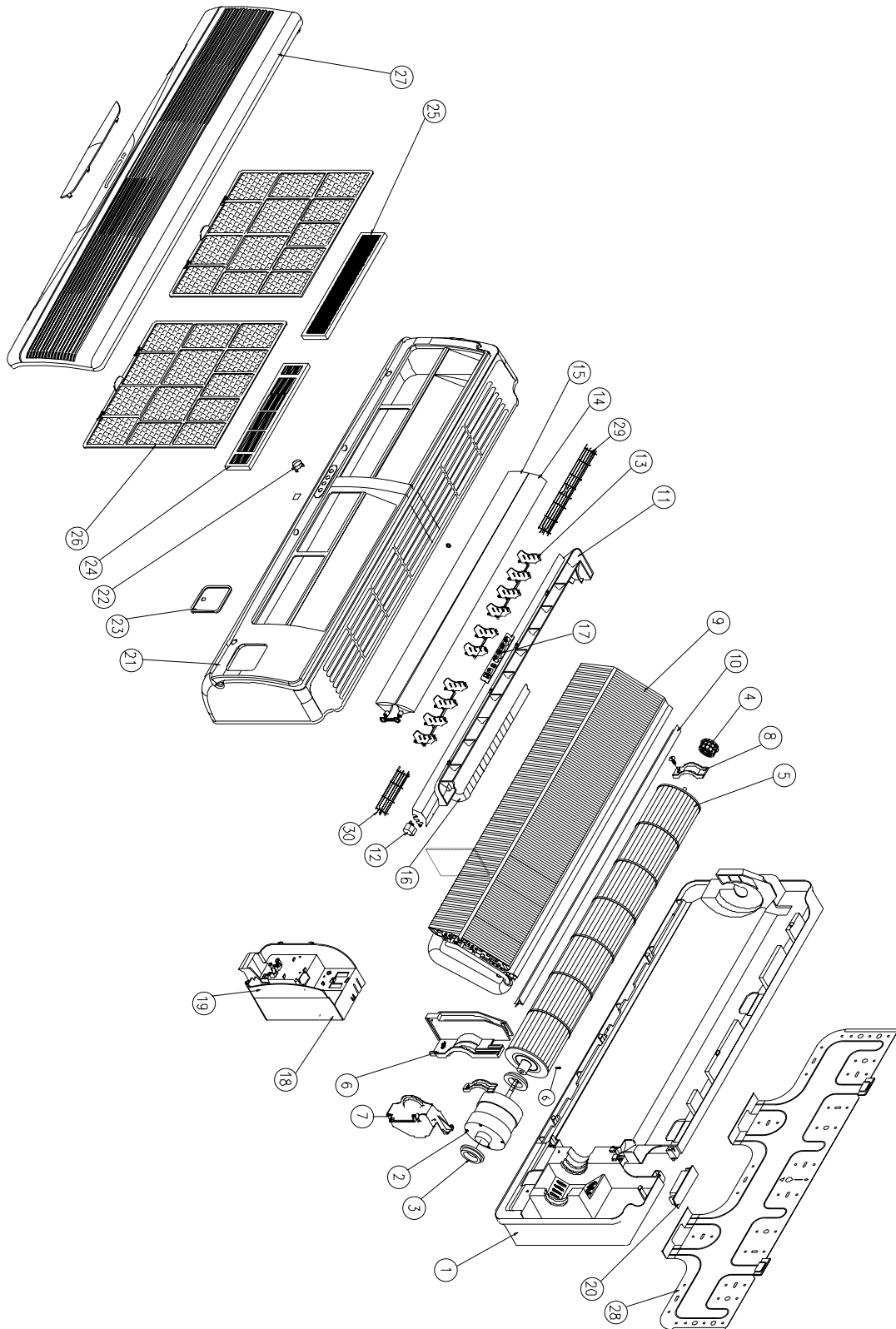

## ◆Indoor Unit Part List (TAS-18,24H)

✓ **Caution** : In this Manual, some parts can be changed for improving, their performance without notice in the parts list. So, if you need the latest parts information, please refer to PPL(Parts Price List) in Service Information Center (<http://svc.dwe.co.kr>).

No	PART CODE	PART NAME	Q'TY	SPEC	REMARK
1	3100076200	BODY Ass`y	1	HIPS T2.5	
2	3108008220	MOTOR IDU	1	FDA3530DWC	
3	3111503800	CUSHION MOTOR	2	CR	
4	3106400200	BEARING PLASTIC Ass`y	1	O.D.ø37.0xI.D.ø6.0	
5	3100076400	CFF Ass`y	1	O.D.ø100xL864	
6	3103003800	HOLDER MOTOR L/B	1		
7	3110606700	BRACKET MOTOR	1	HIPS T2.0	
8	3103004000	HOLDER BEARING	1	ABS T2.5	
9	311009AC11	EVAP. Ass`y	1	Fp=1.4 , 2R-5C	TAS-18H
	311009AC01			Fp=1.4 , 2R-5C	TAS-24H
10	3102501400	GUIDE EVAP.	1		
11	3100076810	PAN DRAIN Ass`y	1	HIPS T2.0 (GY258A)	
12	3108007600	MOTOR STEPPING	1	GSP-24RW-062	
13	3106502700	BLADE VERTICAL M	2.5	P.P. T1.5	
14	3107600500	FLAP UP	1		
15	3107600600	FLAP DOWN	1		
16	3103200800	DRAIN HOSE Ass`y	1		
17	3104301700	LED PCB Ass`y	1		
18	3100077060	CONTROL BOX Ass`y	1	P.P. + Talk 20%	
19	3104308800	CONTROL PCB Ass`y	1		
20	3100400700	BODY TOP	1		
21	3100077150	FRAME GRILLE Ass`y	1		
22	3103401400	KNOB SWITCH	1		
23	3101406820	COVER T/BLOCK	1	ABS	
24	3100094400	FILTER ELECTRO Ass`y	1	WHITE	
25	3100094300	FILTER CARBON Ass`y	1	BLACK	
26	3102201500	FILTER FRAME	2		
27	3100077200	INSERT GRILLE Ass`y	1		
28	3104511800	PLATE MOUNTING	1	SGCC T0.7	
29	3112501510	GUIDE SAFETY - C	1	SUS304 ø1.5 (Black)	
30	3112501520	GUIDE SAFETY - D	2	SUS304 ø1.5 (Black)	

## 2 OUTDOOR UNIT

◆TAS-12, 15, 18HO

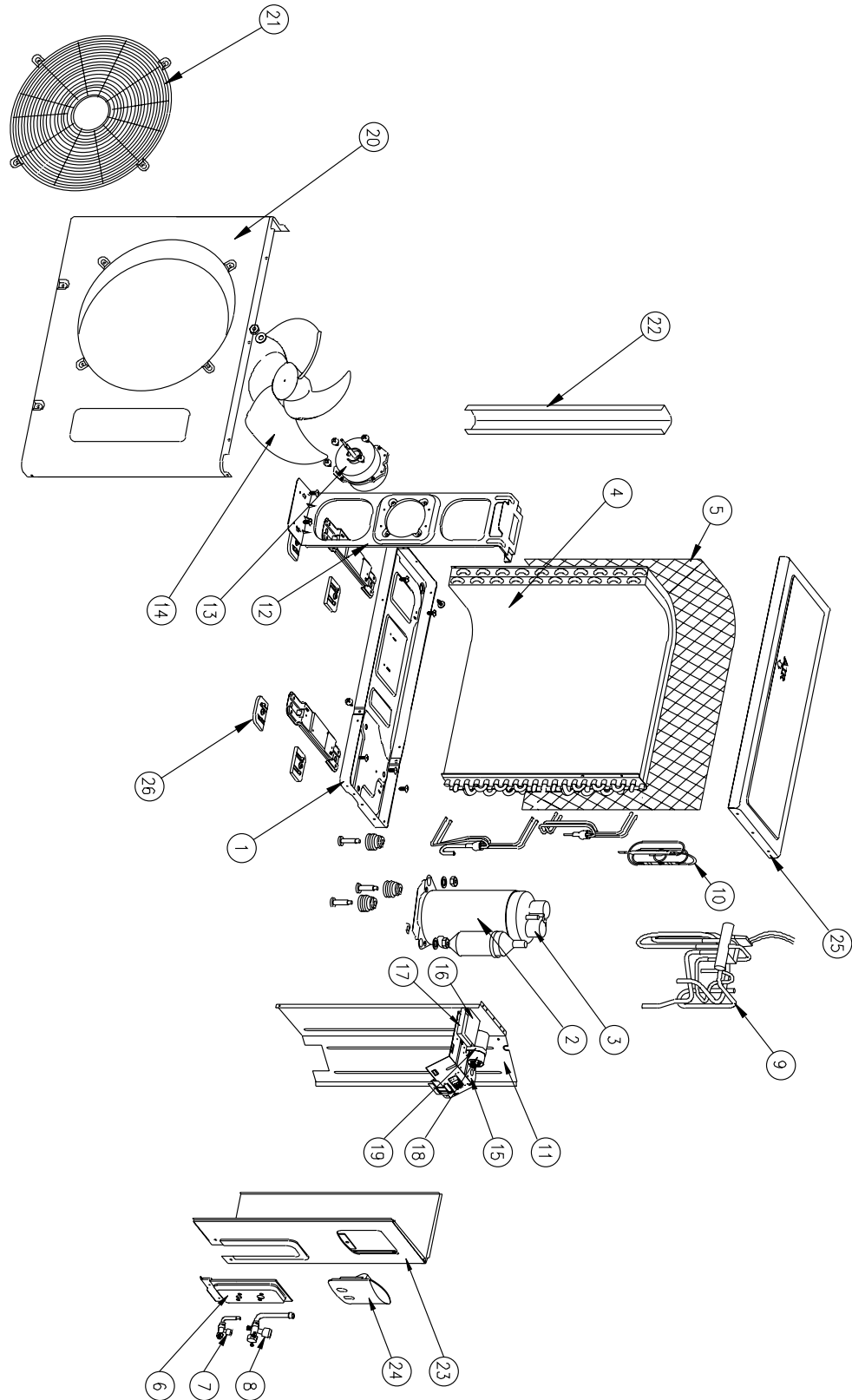

## ◆Outdoor Unit Part List (TAS-12,15,18HO)

✓ **Caution** : In this Manual, some parts can be changed for improving, their performance without notice in the parts list. So, if you need the latest parts information, please refer to PPL(Parts Price List) in Service Information Center (<http://svc.dwe.co.kr>).

No	PART CODE	PART NAME	Q'TY	SPEC	REMARK
1	311000750P	PAN BASE Ass'y	1	SECC T1.2 (GY-171D)	
2	3117146100	COMPRESSOR	1	QK173KAB (LG Rotary)	TAS-12HO
	3117146510		1	QJ222KCC (LG Rotary)	TAS-15HO
	3117143900		1	48D185IU1EH (SS Rotary)	TAS-18HO
3		COMP. OLP	1	MRA 98996-12026	TAS-12HO
			1	MRA 12074-12027	TAS-15HO
			1	MRA 12149-12007	TAS-18HO
4	311009H800	CONDENSER Ass'y	1	L568.4xH575xW25 (2Rx3C)	
5	3112400700	GRILLE COND.	1	PE	
6	310061000P	BRKT SERVICE Ass'y	1	SECC T1.6	
7	3105400200	SERVICE VALVE	1	C3771 1/4"	TAS-12,15,18HO
8	3115401900	SERVICE VALVE	1	C3771 3/8"	TAS-12HO
	3105400100		1	C3771,1/2"	TAS-15,18HO
9	311009HB00	PIPE REVERSING Ass'y	1	CHV-0104	TAS-12HO
	311009HC00		1	CHV-0201	TAS-15HO
	311009HD00		1	CHV-0201	TAS-18HO
10	311009HG00	PIPE CAPILLARY Ass'y	1	C:I.D.Ø1.6xL600 H:I.D.Ø1.6 x L400	TAS-12HO
	311009HF00		1	C:I.D.Ø1.8xL600 H:I.D.Ø1.8 x L300	TAS-15HO
	311009HH00		1	C:I.D.Ø2.0xL900 H:I.D.Ø2.0 x L500	TAS-18HO
11	3114500800	PLATE PARTITION	1	SGCC T1.0	
12	3110600200	BRACKET MOTOR	1	SGCC T1.2	
13	3118007160	MOTOR ODU	1	YDK-50-6A1	
14	3101800100	FAN PROPELLER	1	ABS+G/F(10),OD420,BLK	
15	3110025820	PANEL CONTROL Ass'y	1	SECC T0.8	
16	3114308910	ODU PCB Ass'y	1		
17	3111101600	ODU PCB CASE	1	P.P.+Talk 20%	
18	3109500810	CAPACITOR DUAL	1	3.0+25µF/400VAC	TAS-12HO
	3116903120		1	3.0+35µF/400VAC	TAS-15HO
	3116905300		1	3.0+40µF/450VAC	TAS-18HO
19	3101301100	CLAMP CAPACITOR	1	SECC T1.0	
20	311080021P	CABINET FRONT	1	SECC T0.8	
21	3112400300	GRILLE DISCHARGE	1	STEEL WIRE	
22	3112500300	GUIDE SUPPORT	1	SECC T1.2	
23	311080030P	CABINET SIDE	1	SECC T0.8	
24	3111408300	COVER SERVICE	1	SECC T0.8	
25	311420050P	PANEL TOP	1	SECC T0.8	
26	3102101000	CUSHION RUBBER	4	NR	

◆TAS-24HO

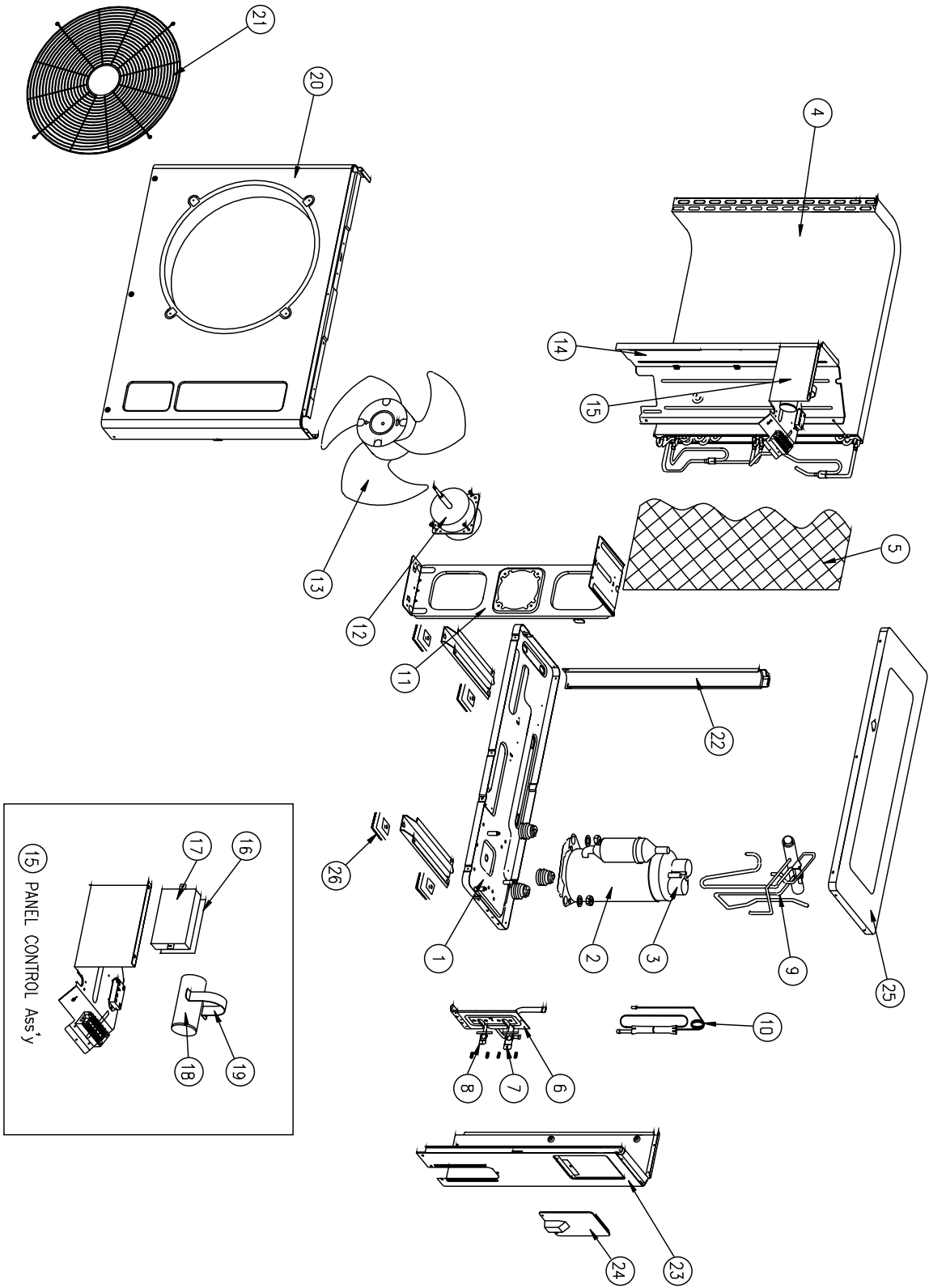

## ◆Outdoor Unit Part List (TAS-24HO)

✓ **Caution** : In this Manual, some parts can be changed for improving, their performance without notice in the parts list. So, if you need the latest parts information, please refer to PPL(Parts Price List) in Service Information Center (<http://svc.dwe.co.kr>).

No	PART CODE	PART NAME	Q'TY	SPEC	REMARK
1	3100041702	PAN BASE Ass'y	1	SECC T1.2 (GY-171D)	
2	3117141200	COMPRESSOR	1	QP325KBB (LG Rotary)	
3		COMP. OLP	1	INTERNAL	
4	3106800500	CONDENSER Ass'y	1		
5	3102402100	GRILLE COND.	1	PE	
6	3100041201	BRKT SERVICE Ass'y	1	SECC T1.6	
7	3105401300	SERVICE VALVE	1	C3771 5/8"	
8	3105401200	SERVICE VALVE	1	C3771 3/8"	
9	311009HE00	PIPE REVERSING Ass'y	1	CHV-0201	
10	310009HH00	PIPE CAPILLARY Ass'y	1	C:I.D.Ø2.0xL400 H:I.D.Ø2.0 x L500	
11	3105300400	SUPPORT MOTOR	1	SGCC-M-Z22 T1.6	
12	3118008000	MOTOR ODU	1	A2929GS010	
13	3101802001	FAN PROPELLER	1	ABS + G.F.20%	
14	3100031702	PLATE PARTITION Ass'y	1	SGCC-M-Z22 T0.8	
15	3100088680	PANEL CONTROL Ass'y	1	SECC T0.8	
16	3114308900	ODU PCB Ass'y	1		
17	3111101600	ODU PCB CASE	1	P.P.+Talk 20%	
18	3116904800	CAPACITOR DUAL	1	5.0+40µF/400VAC	
19	3101201100	CLAMP CAPACITOR	1	SECC T1.0	
20	3100801020	CABINET FRONT	1	SECC T0.8	
21	3102102000	GRILLE DISCHARGE	1	STEEL WIRE	
22	3100041100	GUIDE SUPPORT	1	SECC T1.6	
23	3100031520	CABINET SIDE	1	SECC T0.8	
24	3100089220	COVER SERVICE	1	SECC T0.8	
25	3100041500	PANEL TOP	1	SECC T0.8	
26	311500400	CUSHION RUBBER	4	NR	

AIR CONDITIONER MANUFACTURER  
**Turbo air**

# SERVICE MANUAL

## ROOM AIR CONDITIONER

MODEL #: TAS-12H/HO  
TAS-15H/HO  
TAS-18H/HO  
TAS-24H/HO

### CONTENTS

1. SPECIFICATIONS
2. INSTALLATION
3. REFRIGERANT CYCLE DIAGRAM
4. WIRING DIAGRAM
5. CONTROL BLOCK DIAGRAM
6. TROUBLE SHOOTING
7. PCB DESCRIPTION
8. KEY COMPONENTS OF ELECTRONIC CIRCUIT
9. DISASSEMBLY INSTRUCTIONS
10. EXPLODED VIEW AND PART LIST